

2.5"-SBC-AMV/ADV

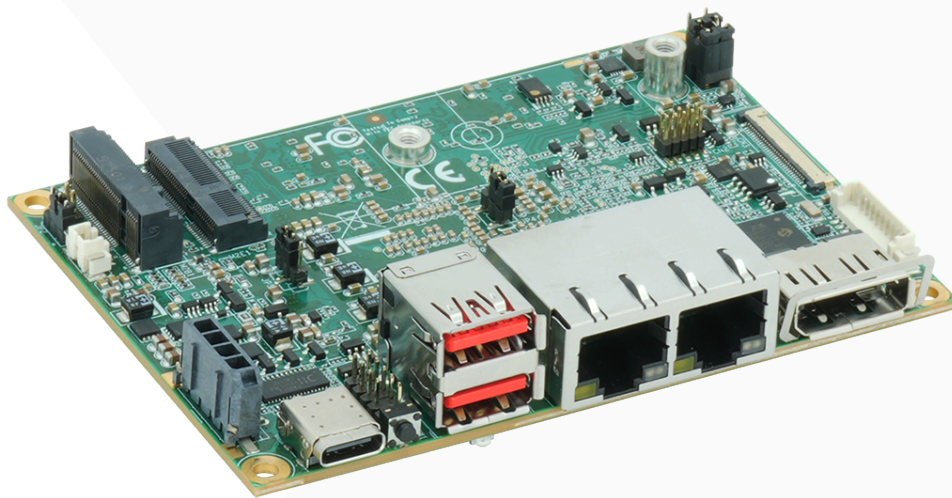

2.5" Single Board Computer with Intel® Atom® x7000(R)E Series, Intel® Core™ i3 N-Series & Intel® N-Series Processors

- Upgraded processing and graphics performance + faster AI inference capability
- Next-gen LPDDR5 memory with up to 4800 MT/s data transfer rate
- DP Alt Mode over USB-C support to carry video / audio, data & power over a single port
- Wide input voltage range for more application environments
- Hardware-based security for data protection and reliable authentication

2.5" Single Board Computer w/ Intel® Atom® x7000(R)E Series, Core™ i3 N-Series & Intel® N-Series

2.5"-SBC-AMV/ADV is a 2.5" single board computer in Pico-ITX form factor powered by Intel® Atom® x7000RE Series (codenamed Amston Lake), Intel® Atom® x7000E Series, Intel® Core™ i3 N-Series and Intel® N-Series (codenamed Alder Lake N) processors integrated with Intel® UHD Graphics Gen12 as well as next-gen high-speed LPDDR5 memory. Thus, it can deliver upgraded performance,

enhanced media transcoding and faster AI inference, making it an ideal baseboard to be integrated into an ultra-compact or portable IoT edge system or an all-in-one solution for a variety of applications, such as smart retail, industrial automation, healthcare, video processing and office automation.

- Intel® Atom® x7000(R)E Series Processors
- Intel® Core™ i3 N-Series Processors
- Intel® N-Series Processors
- 4 GByte / 8 GByte / 16 GByte LPDDR5 memory down
- 2x 2.5 GbE LAN for Ethernet
- 2x DP (1x full DP, 1x USB-C), 1x LVDS / eDP for triple display
- 3x USB 3.2 Gen 2 / Gen 1 (2x Type A, 1x Type C), 2x USB 2.0
- 8x GPIO for device / signal control
- 32 GByte / 64 GByte / 128 GByte eMMC for storage
- 1x M.2 Key B for SSD, WWAN or other possible expansion
- 1x M.2 Key E for WLAN, Bluetooth or other expansion
- TPM 2.0 support

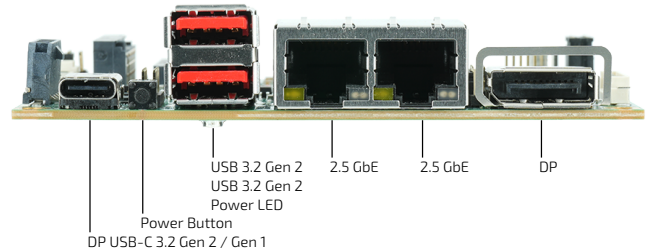

Block Diagram

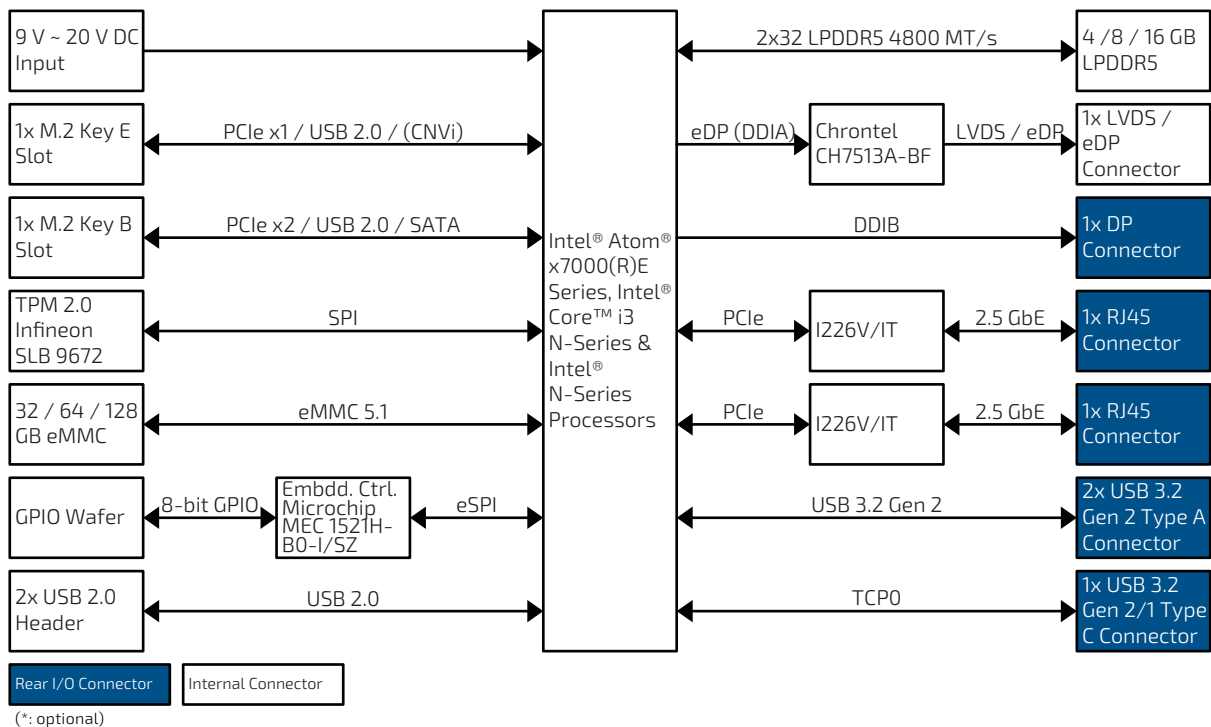

SYSTEM	PROCESSOR (STANDARD)	Intel® Atom® x7433RE (Quad Core, 6M Cache, 1.5 / 3.4 GHz, 9 W TDP) Intel® Atom® x7835RE (Octa Core, 6M Cache, 1.3 / 3.6 GHz, 12 W TDP) Intel® Core™ i3-N305 (Octa Core, 6M Cache, 1.8 / 3.8 GHz, 9 W ← 15 W TDP)
	PROCESSOR (PROJECT BASE)	Intel® Atom® x7211RE (Dual Core, 6M Cache, 1.0 / 3.2 GHz, 6 W TDP) Intel® Atom® x7213RE (Dual Core, 6M Cache, 2.0 / 3.4 GHz, 9 W TDP) Intel® Atom® x7211E (Dual Core, 6M Cache, 1.0 / 3.2 GHz, 6 W TDP) Intel® Atom® x7213E (Dual Core, 6M Cache, 1.7 / 3.2 GHz, 10 W TDP) Intel® Atom® x7425E (Quad Core, 6M Cache, 1.5 / 3.4 GHz, 12 W TDP) Intel® N50 (Dual Core, 6M Cache, 1.0 / 3.4 GHz, 6 W TDP) Intel® N97 (Quad Core, 6M Cache, 2.0 / 3.6 GHz, 12 W TDP) Intel® N200 (Quad Core, 6M Cache, 1.0 / 3.7 GHz, 6 W TDP)
	MEMORY	4 GByte / 8 GByte / 16 GByte LPDDR5 4800 memory down
VIDEO	GRAPHICS DISPLAY INTERFACE	Intel® UHD Graphics Gen12 1x LVDS (24-bit, 2-ch, 1920 x 1200 @ 60 Hz) / eDP (4096 x 2160 @ 60 Hz) 2x DP (4096 x 2160 @ 60 Hz, 1x Full-size DP on rear, 1x DP USB-C on rear)
	MULTIPLE DISPLAY	Triple Display
NETWORK CONNECTION	ETHERNET	2x 2.5 GbE LAN (RJ45 on rear, Intel® I226-V/IT, TSN support*)
PERIPHERAL CONNECTION	USB	2x USB 3.2 Gen 2 Type A (on rear) 1x USB 3.2 Gen 2 Type C (on rear, w/ DP & PD 5 V / 3 A, except Atom® x7000RE) 1x USB 3.2 Gen 1 Type C (on rear, w/ DP & PD 5 V / 3 A, only Atom® x7000RE) 2x USB 2.0 (by header) 8x GPIO (by wafer)
	OTHER I/Os	
STORAGE & EXPANSION	eMMC M.2	32 GByte / 64 GByte / 128 GByte eMMC 1x M.2 Key B (Type 2242/3042/3052/2280, w/ PCIe x2 / USB 2.0 / SATA / UIM) 1x M.2 Key E (Type 2230, w/ PCIe x1 / USB 2.0 / CNVl**)
	SIM CARD HOLDER	1x SIM Card Holder (by Wafer)
POWER	INPUT VOLTAGE CONNECTOR	DC 9 V - 20 V 1x4-pin pitch 3.0 mm Wafer
FIRMWARE	BIOS WATCHDOG H/W MONITOR REAL TIME CLOCK SECURITY	AMI uEFI BIOS w/ 256 Mb SPI Flash Programmable WDT to generate system reset event Voltages, Temperatures Processor integrated RTC TPM 2.0 Support (Infineon SLB 9672)
SYSTEM CONTROL & MONITORING	BUTTON, SWITCH & INDICATOR	1x Power Button (on rear) 1x Power LED (Green, on board)
	FP HEADER	1x Header for Power Button, Reset Button, Power LED & SATA LED
SOFTWARE	OS SUPPORT	Windows 11, Windows 10, Linux
MECHANICAL	DIMENSION (L x W)	Pico-ITX (100 mm x 72 mm / 3.94" x 2.83")
ENVIRONMENTAL	OPERATING TEMPERATURE	0 °C - 60 °C / 32 °F - 140 °F (Standard) -40 °C - 85 °C / -40 °F - 185 °F (Extreme)
	STORAGE TEMPERATURE	-20 °C - 80 °C / -4 °F - 176 °F (Standard) -55 °C - 85 °C / -67 °F - 185 °F (Extreme)
	HUMIDITY	0 % - 95 %
COMPLIANCE	EMC SAFETY	CE Class B, FCC Class B, ICES Class B, UKCA UR (UL Recognized), CSA

* TSN support for models with Atom® processors

** Atom® x7000RE Series processors do not support CNVl

Ordering Information

ARTICLE	ORDER CODE#	PROCESSOR	LAN CHIP	LPDDR5	eMMC	OPERATING TEMP.
	EMEA / AMER					
2.5"-SBC-AMV-0-x7835RE-XT	TBD	Intel® Atom® x7835RE	Intel® I226-IT	16 GB	128 GB	-40 °C ~ 85 °C
2.5"-SBC-AMV-1-x7433RE-XT	TBD	Intel® Atom® x7433RE	Intel® I226-IT	8 GB	128 GB	-40 °C ~ 85 °C
2.5"-SBC-ADV-0-i3-N305	TBD	Intel® Core™ i3-N305	Intel® I226-V	8 GB	64 GB	0 °C ~ 60 °C

#: For ordering code for APAC, contact your local account manager.

Contact your account manager for other processor variants, LPDDR5 variants, eMMC variants or operating temperature ranges.

Accessories

NO.	ARTICLE	ORDERING CODE		DESCRIPTION
		EMEA / AMER	APAC	
1	DC IN CABLE*	1064-2433	0C5020000004220L	2.5 mm DC Jack to H-300F-XX 1x4P 3.0 mm pitch, L = 300 mm
2	COM PORT CABLE#	1064-2427	0C5020000005130L	1x10P 1.25 mm pitch to DB9 connector, L = 350 mm
3	GPIO CABLE	1065-3137	0C5020000003360L	D-SUB-9P (Female) to MX51021-10P 1x10P 1.25 mm pitch, L = 200 mm
4	USB CABLE (2 PORT)	1069-7893	0C5020003000010L	2x5P 2.0 mm pitch to 2x USB 2.0 Type A female w/ bracket, L = 27 cm
5	ADAPTER	1069-3055	0I0902GST60A106L	Input: AC 90 V ~ 264 V, output: DC 12 V @ 5 A Max. 60 W
6	COPPER PILLAR KIT	TBD	OZHK35SBC0000001	4x 39.6 mm pillar, 3x 19L pillar, 4x 15L screw, 1x 5L screw
7	HEATSINK	1074-8498	OZHK25SADN0000C1	Al heatsink w/ pads, 2x standoff, 4x pillar, 6x screw, for 2.5"-SBC-ADN/ADV
8	HEATSINK	1074-8828	OZHK25SAML0000A3	Al +Cu heatsink w/ pads, 2x standoff, 4x pillar, 6x screw, 2.5"-SBC-AML/AMV

*: standard supplied accessories for single-piece box packing

#: not applicable to 3.5"-SBC-AMV/ADV

Starter Kits

ARTICLE	ORDERING CODE		DESCRIPTION
	EMEA / AMERICA	APAC	
STARTER KIT FOR 2.5"-SBC-ADN/ADV	1074-6151	OZHK25SADN0000C2	Including above accessories table No. 1 ~ 6 & 7
STARTER KIT FOR 2.5"-SBC-AML/AMV	1074-7412	OZHK25SAML0000A4	Including above accessories table NO. 1 ~ 6 & 8

Global Headquarters

Kontron Europe GmbH

Gutenbergstraße 2
85737 Ismaning, Germany
Tel.: + 49 821 4086-0
info@kontron.com

www.kontron.com

kontron
The Power of IoT