



BL i.MX8M Plus QC

Doc. Rev 1.1

Disclaimer

Kontron Electronics would like to point out that the information contained in this user guide may be subject to alteration, particularly as a result of the constant upgrading of Kontron Electronics products. This document does not entail any guarantee on the part of Kontron Electronics with respect to technical processes described in the user guide or any product characteristics set out in the user guide. Kontron Electronics assumes no responsibility or liability for the use of the described product(s), conveys no license or title under any patent, copyright or mask work rights to these products and makes no representations or warranties that these products are free from patent, copyright or mask work right infringement unless otherwise specified. Applications that are described in this user guide are for illustration purposes only. Kontron Electronics makes no representation or warranty that such application will be suitable for the specified use without further testing or modification. Kontron Electronics expressly informs the user that this user guide only contains a general description of processes and instructions which may not be applicable in every individual case. In cases of doubt, please contact Kontron.

Copyright

This user guide is protected by copyright. All rights are reserved by Kontron. No part of this document may be reproduced, transmitted, transcribed, stored in a retrieval system, or translated into any language or computer language, in any form or by any means (electronic, mechanical, photocopying, recording, or otherwise), without the express written permission of Kontron. Kontron Electronics points out that the information contained in this user guide is constantly being updated in line with the technical alterations and improvements made by Kontron Electronics to the products and thus this user guide only reflects the technical status of the products by Kontron Electronics at the time of publishing.

Brand and product names are trademarks or registered trademarks of their respective owners.

©2025 by Kontron Electronics GmbH

YOUR CONTACT

Kontron Electronics GmbH
Max-Planck-Str. 6
72636 Frickenhausen
Germany

<https://www.kontron-electronics.com>

GLOBAL HEADQUARTERS

Kontron-Europe-GmbH
Gutenbergstr. 2
85737 Ismaning
Germany

<https://www.kontron.com>

Intended Use

THIS DEVICE AND ASSOCIATED SOFTWARE ARE NOT DESIGNED, MANUFACTURED OR INTENDED FOR USE OR RESALE FOR THE OPERATION OF NUCLEAR FACILITIES, THE NAVIGATION, CONTROL OR SUPPORT OR LIFE SUSTAINING APPLICATIONS, WEAPONS SYSTEMS, OR ANY OTHER APPLICATION IN A HAZARDOUS ENVIRONMENT, OR REQUIRING FAIL-SAFE PERFORMANCE, OR IN WHICH THE FAILURE OF PRODUCTS COULD LEAD DIRECTLY TO DEATH, PERSONAL INJURY, OR SEVERE PHYSICAL OR ENVIRONMENTAL DAMAGE (COLLECTIVELY, "HIGH RISK APPLICATIONS").

You understand and agree that your use of Kontron Electronics devices as a component in High-Risk Applications is entirely at your risk. To minimize the risks associated with your products and applications, you should provide adequate design and operating safeguards. You are solely responsible for compliance with all legal, regulatory, safety, and security related requirements concerning your products. You are responsible to ensure that your systems (and any Kontron Electronics hardware or software components incorporated in your systems) meet all applicable requirements. Unless otherwise stated in the product documentation, the Kontron Electronics device is not provided with error tolerance capabilities and cannot therefore be deemed as being engineered, manufactured or setup to be compliant for implementation or for resale as device in High-Risk Applications. All application and safety related information in this document (including application descriptions, suggested safety measures, suggested Kontron Electronics products, and other materials) is provided for reference only.



Demo software

If the product is delivered with demo software, this software is intended for testing purposes only and is not permitted for real use!

Revision History

Table 1: Revision History

Revision	Brief Description of Changes	Date of Issue	Author/Editor
Rev. 0.1	Initial draft version	23.07.2025	Tur
Rev. 1.0	Final release	25.02.2026	We
Rev. 1.1	Minor corrections and clarifications	09.03.2026	Tur/We

Terms and Conditions

Kontron Electronics warrants products in accordance with defined regional warranty periods. For more information about warranty compliance and conformity, and the warranty period in your region, visit www.kontron-electronics.com/downloads

For contact information, refer to the corporate offices contact information on the last page of this user guide or visit our website CONTACT US.

Customer Support

Find Kontron Electronics contacts by visiting: www.kontron-electronics.com

Customer Comments

If you have any difficulties using this user guide, discover an error, or just want to provide some feedback, contact support@kontron-electronics.de. Detail any errors you find. We will correct the errors or problems as soon as possible and provide the revised user guide.

Table of Contents

1	List of Tables	7
2	List of Figures.....	7
3	Symbols.....	8
4	Safety Instructions.....	9
5	Instructions on Handling, Unpacking and Usage	11
5.1	ESD („Electrostatic Discharge“)	11
5.2	Packaging	11
5.3	Scope of Delivery.....	12
5.4	Label and Product Identification.....	12
5.5	General Instructions on Usage	12
6	Introduction	13
7	Starting Up	14
7.1	Connecting to Power Supply	14
7.2	Wiring the DC Mating Power Connector	15
7.3	Operating System (OS) and Drivers	15
8	Product Overview	16
8.1	Main Characteristics	16
8.2	Product Variants.....	17
8.3	Related Products and Accessories	18
9	System Specification	19
9.1	Technical Specification	19
9.2	Environmental Specification	20
9.3	Mechanical Specification	21
9.4	Power Specification	22
9.5	Earthing System	24
9.6	Functional Block Diagram.....	25
9.7	Thermal Considerations.....	26
9.8	Standards, Certifications and Directives.....	26
10	Board and Connectors.....	27
10.1	Connector Details.....	28
10.1.1	Power Connector.....	28
10.1.2	MIPI CSI Interface	28
10.1.3	Ethernet (LAN2, LAN1) Interface.....	28
10.1.4	Buzzer	28
10.1.5	USB 2.0 Interface.....	28
10.1.6	RS232 Interface.....	28
10.1.7	RS485 Interface	28
10.1.8	CAN Interface	29
10.1.9	DIO Interface	29
10.1.10	Debug Interface	29
10.1.11	USB-C Interface	29
10.1.12	MicroSD Card Slot	30

10.1.13	Functional Earth Connection.....	30
10.1.14	Extension Connector.....	30
10.1.15	LVDS Interface.....	30
10.1.16	Power Button.....	30
10.1.17	Reset Button.....	30
10.1.18	Recovery Mode Switch.....	30
10.1.19	HDMI Interface.....	30
10.2	Connector Pin Assignments.....	31
10.2.1	Input Power Connector (X101).....	31
10.2.2	MIPI CSI Connector (X701).....	31
10.2.3	Ethernet RJ45 Connector (X1001 + X1101).....	32
10.2.4	USB Connector (X1201).....	32
10.2.5	RS232 Connector (X1401).....	33
10.2.6	RS485/CAN Connector (X1402).....	33
10.2.7	CAN Address and Termination Switch (S1401).....	33
10.2.8	DIO Connector (X1501).....	34
10.2.9	Debug Connector (X201).....	34
10.2.10	USB-C Connector (X1301).....	35
10.2.11	LVDS-Family Connector (X901).....	35
10.2.12	Extension Connector (X1601).....	36
10.2.13	MicroSD Card Slot (X601).....	37
10.2.14	HDMI Connector (X801).....	37
11	Accessing Components and Extending the Device.....	38
11.1	MicroSD Card Slot.....	38
11.2	Extending the Device.....	38
12	Storage, Transportation and Maintenance.....	39
12.1	Storage.....	39
12.2	Transportation.....	39
12.3	Maintenance.....	39
12.4	Replacing the Coin Cell Battery.....	40
13	Technical Support.....	41
13.1	First Steps – Startup Information Baseboard.....	41
13.2	License Information.....	41
14	Product Usage Life Cycle.....	42
14.1	Warranty.....	42
14.2	Quality and Environmental Management.....	43
14.3	Disposal and Recycling.....	43
14.4	WEEE Compliance.....	43
15	Appendix.....	44

1 List of Tables

Table 1: Revision History.....	4
Table 2: Wiring the Power Mating Connector.....	15
Table 3: Product Variants of BL i.MX8M Plus QC	17
Table 4: Accessories for BL i.MX8M Plus QC	18
Table 5: Technical Specification	19
Table 6: Software Specification.....	19
Table 7: Environmental Conditions	20
Table 8: Mechanical Specification.....	21
Table 9: Power Specification	22
Table 10: Power Consumption.....	24
Table 11: Standards, Certifications and Directives Compliance	26
Table 12: Overview of Components and Connectors.....	27
Table 13: List of Acronyms	44

2 List of Figures

Figure 1: BL i.MX8M Plus QC Label (Example)	12
Figure 2: BL i.MX8M Plus QC	16
Figure 3: Development Kit DK i.MX8M Plus QC and DK 7" i.MX8M Plus QC.....	17
Figure 4: Board Dimensions	21
Figure 5: Power Tree	23
Figure 6: Block Diagram	25
Figure 7: Top Side View	27
Figure 8: USB-UART Debug-Adapter.....	29

3 Symbols

The following Symbols may be used in this user guide:



DANGER

Indicates an imminently hazardous situation, which, if not avoided, will result in death or serious injury.



WARNING

Indicates a potentially hazardous situation which, if not avoided, could result in death or serious injury.



CAUTION

Indicates a potentially hazardous situation which, if not avoided, may result in minor or moderate injury. It may also be used to alert against unsafe practices.



NOTICE

Indicates a property damage message.



ESD Sensitive Device

This symbol and title inform that the electronic boards and their components are sensitive to static electricity. Care must always therefore be taken during all handling operations and inspections of this product in order to ensure product integrity at all times.



HOT Surface

Do NOT touch! Allow to cool before servicing.



Information

This symbol indicates general information about the product and the user guide.



Hints and Tips

This symbol precedes helpful hints and tips for daily use.

4 Safety Instructions

Before you begin the installation and operation of the product, please carefully read all safety instructions and warnings. Pay attention to any warning notices attached. Kontron Electronics accepts no liability for damage to equipment or persons resulting from failure to follow the basic safety instructions, even during the warranty period, and is therefore exempt from statutory liability for accidents. The product has been designed and tested in accordance with basic safety requirements and legal guidelines. To ensure safe operation, the user must not only observe the intended operating conditions of the product but also follow the basic safety instructions:

- The product must be used in accordance with the user guide or datasheet.
- All instructions for installation, operation, maintenance, transport or storage that are necessary for the safety of the product or the user must be followed.
- The electrical connection on site must comply with the requirements of the local, country-specific regulations.
- Do not place the appliance near heat sources or in damp locations.
- The only way to completely disconnect the product from the mains power is to disconnect the power supply cable from the power adapter or from the product itself.
- Note: The product is not disconnected from the power supply when it is switched off using the power button or the software.
- Only original accessories approved by Kontron Electronics may be used.
- The available interfaces may only be used with devices and components that comply with the specifications listed in the user guide.
- Ensure that the power consumption of the product does not exceed the value specified on the rating plate and in the user-guide.
- If the product stops working properly, switch it off and secure it to prevent it from being turned on again.
- Basic ESD protection measures must be observed (see user guide).
- AL and DL series products should only be opened to replace a depleted coin cell battery. Before opening the housing, disconnect the power supply and ensure that the product is completely de-energized. Ensure that all interfaces of the device are also disconnected.



WARNING

Risk of explosion if the battery is not replaced according to the instructions! (short circuit, reverse polarity, incorrect battery type). Dispose of used batteries in accordance with the manufacturer's instructions.



CAUTION: Risk of Overheating

Sufficient air circulation or cooling is essential to protect the product from overheating. When cooling by air circulation, make sure that the ventilation openings and heat sinks of the product are not covered. Overheating can affect the proper functioning of the product and, in the worst case, lead to its destruction. High ambient temperatures can make cooling more difficult. The ambient temperature limits specified in the user guide must be observed.



CAUTION: Hot Surface

There is a risk of injury from contact with heated components or the housing.

Important notes on the power supply

- Please note: Safe use of the product is only possible if the external DC power supply meets the criteria for LPS and PS2 (UL/IEC 62368-1).
- Connect the product only to a power supply (PSU) that provides the input power (max. current) specified on the Kontron nameplate or in the User-Guide and that complies with the Limited Power Source (LPS) and Power Source (PS2) requirements of UL/IEC 62368-1.
- Safe operation is not possible if exposed parts of circuits carrying dangerous voltages or energies can be touched directly or indirectly.
- Safe operation is not possible if there is no disconnecting device that removes the hazardous energy content from the point of disconnection within 2 seconds.
- The cross-section of the supply wires must be selected in accordance with the maximum current specified on the nameplate of the device, in accordance with the provisions of EN62368-1 or VDE0100 or EN60204 or UL61010-1.
- The power supply serves as the primary disconnect device from the mains (AC) and is used to remove all DC power from the board / system.
- The AL or DL housing must be earthed using the screw provided.

Additional safety information for BL

Please note when extending the device:

- When installing additional modules, ensure that the workspace is clean.
- After installing the additional modules, please check the product for any damage.
- The power consumption of each additional module must not exceed the specified limit.
- Structural changes and modifications must be approved by Kontron Electronics. Unauthorised structural modifications and conversions will result in the loss of any warranty.
- Only trained personnel are authorised to handle and operate the device.

Additional safety instructions for the Development Kit

- Regularly check the unit's components, accessories and power supply for damage.
- Only trained personnel are authorised to handle and operate the appliance.
- The product is a customised, application-specific test module intended for exclusive use by experts in research and development facilities for research and development purposes. (§2 section 3 paragraph 3 EMVG)

5 Instructions on Handling, Unpacking and Usage

5.1 ESD („Electrostatic Discharge“)



ESD Sensitive Device

Electrostatic discharge (ESD) can damage equipment and impair electrical circuitry.

- Wear ESD-protective clothing and shoes.
- Wear an ESD-preventive wrist strap attached to a good earth ground.
- Check the resistance value of the wrist strap periodically (OK: 1 MΩ to 10 MΩ).
- Transport and store the board in its antistatic bag.
- Handle the board at an approved ESD workstation.
- Handle the board only by the edges.

Do not handle this product out of its protective enclosure while it is not used for operational purposes unless it is otherwise protected.

Whenever possible, unpack or pack this product only at EOS/ESD safe workstations. Where a safe workstation is not guaranteed, it is important for the user to be electrically discharged before touching the product with hands or tools.

It is particularly important to observe standard anti-static precautions when changing piggybacks, ROM devices, jumper settings etc. If the product contains batteries for RTC or memory backup, ensure that the product is not placed on conductive surfaces, including anti-static plastics or sponges. They can cause short circuits and damage the batteries or conductive circuits on the product.

5.2 Packaging

All parts are delivered together in a product specific cardboard package designed to provide adequate protection and absorb shock. Kontron Electronics recommends keeping the packaging to store or transport the product. If it is necessary to store or ship the product then repack it in the same manner as it was delivered.

Please inspect the delivery immediately upon receipt for completeness and integrity. Check the product, the packaging, and any seals that may be present for visible damage or signs of tampering.

If you notice any discrepancies, damage, or missing components, please contact our support team without delay.



Unpacking

Proceed as follows to unpack the unit:

- Remove packaging.
- Do not discard the original packaging. Keep packaging for future relocation or storage.
- Check the delivery for completeness by comparing it with the original order.
- Keep the associated paperwork. It contains important information for handling the unit.
- Check the contents for visible shipping damage.

5.3 Scope of Delivery

Included in this delivery:

- BL i.MX8M Plus QC
- Safety Instructions
- DC Power Connector (2-pin Phoenix Contact)

5.4 Label and Product Identification

Figure 1: BL i.MX8M Plus QC Label (Example)

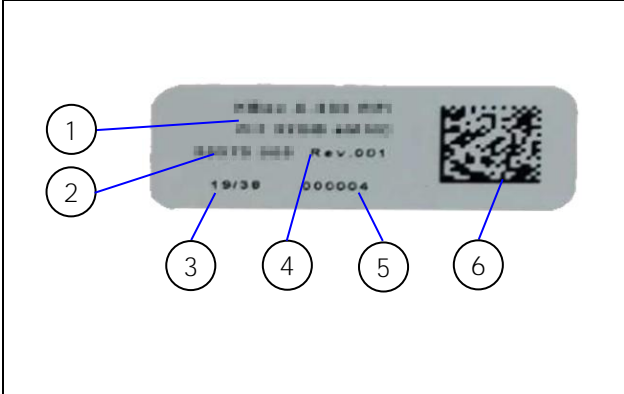
	Detail	Description
 <p>1</p>	1	Product name (BL i.MX8M Plus QC)
<p>2</p>	2	Article number
<p>3</p>	3	Production date
<p>4</p>	4	Revision number
<p>5</p>	5	Serial number
<p>6</p>	6	Data-Matrix-Code with article-, rev., date and serial number

5.5 General Instructions on Usage

In order to maintain Kontron Electronics' product warranty, this product must not be altered or modified in any way. Changes or modifications to the product, that are not explicitly approved by Kontron Electronics and described in this user guide or received from Kontron Electronics Support as a special handling instruction, will void your warranty.

This product should only be installed in or connected to systems that fulfil all necessary technical and specific environmental requirements. This also applies to the operational temperature range of the specific board version that must not be exceeded. If batteries are present, their temperature restrictions must be considered.

In performing all necessary installation and application operations, only follow the instructions supplied by the present user guide.

6 Introduction

This user guide describes the single board computer BL i.MX8M Plus QC. The module uses an ARM-based architecture and is powered by the NXP i.MX8M Plus processor. The quad core SoC takes advantage of the optimized power consumption and performance ratio.

The use of this user guide implies a basic knowledge of PC hardware and software. This user guide is focused on describing the special features and is not intended to be a standard PC textbook. New users are recommended to study the short installation procedure, before switching on the power.

All configuration and setup of the module is performed using the u-Boot CLI. Latest revision of this user guide, datasheet, and BSPs (Board Support Packages) can be downloaded from Kontron Electronics Web Page.

Kontron Electronics' BL i.MX8M Plus QC is a powerful and cost-effective baseboard for machine learning and computing-intensive system architectures. The fanless design ensures a significantly prolonged lifespan and high system availability.



Exploring the BL i.MX8M Plus QC

Before working with the BL i.MX8M Plus QC, Kontron Electronics recommends that users take a few minutes to learn about the various parts of the BL i.MX8M Plus QC.

7 Starting Up

Before using the system, become familiar with the system components and follow the startup instructions below.

7.1 Connecting to Power Supply

The BL i.MX8M Plus QC connects to a DC main power supply via a Phoenix Contact input power connector and corresponding power cable.



Information

When starting the BL i.MX8M Plus QC, Kontron Electronics recommends that the power cable should be the last connection made to the system. Following the proper cabling sequence helps prevent false power-on conditions, which could otherwise lead to operational failures.



CAUTION

Please make sure to read the safety instructions at the beginning of this user guide before connecting the BL i.MX8M Plus QC to a power supply.



WARNING

The current of the power supply should be limited to 3 A.

7.2 Wiring the DC Mating Power Connector

The BL i.MX8M Plus QC is connected by the input power connector on the front to a DC power source via a DC power supply wiring consisting of the power mating connector and the assembled wires. For information on how to wire the connector, see next Chapter.

Table 2: Wiring the Power Mating Connector

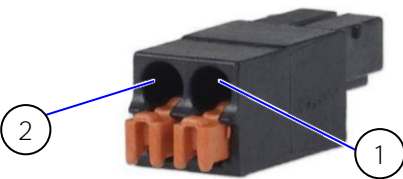
2-Pin Power Mating Connector	Pin	Signal Name
	1	Location for inserting the 24 V wire
	2	Location for inserting the 0 V wire



WARNING

The current of the power supply should be limited to 3 A.

To wire the power mating connector, follow the steps below:

- Cut two (0.5...1.5 mm²) AWG 20...16 isolated wires to the required length and strip each end 5...7 mm.
- Twist the striped wire-ends and provide them with ferrules.
- Press the contact levers of the power mating connector down - far enough so that you can insert the end of the prepared wires.
- Insert the wires into the corresponding clamp of the Phoenix power mating connector. Make sure that you have the right polarity of the connection. For the pin assignment of the input power connector, refer to Chapter 10.2



Information

The wires used for power connections must be clearly marked (+/-) to ensure proper connection to the input power connector and to the main power source. In addition, the cables must have some form of support to minimize the strain on the unit's connectors.

7.3 Operating System (OS) and Drivers

The standard BL i.MX8M Plus QC is fully operational when switched on for the first time with pre-installed OS and drivers. Drivers are available from Kontron Electronics' GitLab Server <https://git.kontron-electronics.de>.

If ordered without pre-installed OS, before starting the BL i.MX8M Plus QC the operating system and the appropriate drivers need to be installed for the ordered system configuration.

8 Product Overview

The BL i.MX8M Plus QC is a flexible single board computer fanless device designed for use in demanding applications. Based on the i.MX8M Plus (4x Arm®Cortex®-A53, 1x Arm® Cortex®-M7) quad core processor the BL i.MX8M Plus QC features long-term availability and supports a varied number of onboard interfaces to enable connectivity to nearly all applications. A microSD card slot supports memory expansion for flexible data storage.



Information

All variants are also available as a separate product named Automation-Line AL i.MX8M Plus QC with aluminium housing.



Figure 2: BL i.MX8M Plus QC

8.1 Main Characteristics

Main characteristics of the BL i.MX8M Plus QC are:

- i.MX8M Plus MIMX8ML8CVNKZAB:
 - 4x Arm® Cortex®-A53 @1,6 GHz
 - 1x Arm® Cortex®-M7 processor @800 MHz
 - 2D and 3D graphics
 - NPU with up to 2.3 TOPS
- 1 GByte up to 8 GByte LPDDR4 RAM
- 4 GByte up to 128 GByte eMMC
- RTC with Battery
- microSD card slot
- Interfaces: 1x HDMI, 2x Ethernet, 2x USB 2.0 Host, 1x USB 3.0 Type-C, 1x RS232, 1x RS485, 1x CAN FD, 4x DIO, 1x LVDS, 1x MIPI CSI, 1x UART, 1x Extension Connector
- Fanless passive cooling (heatsink required)

The BL i.MX8M Plus QC is intended for 24/7 continuous operation and longtime industrial applications. All components are selected to ensure a long lifetime.

8.2 Product Variants

Table 3: Product Variants of BL i.MX8M Plus QC

Board	Description	Product Number
BL i.MX8M Plus QC 4 GB/32 GB	Board Line with NXP i.MX8M Plus quad core processor, 4 GB LPDDR4 and 32 GB eMMC	40099 313
DK i.MX8M Plus QC 4 GB/32 GB	Board Line mounted on acrylic plate, Power Supply, Connector Set, Debug-Adapter, USB-Cable	50099 089
DK 7" i.MX8M Plus QC 4 GB/32 GB	7" Touch Display and Board Line mounted on acrylic plate, Power Supply, Connector Set, Debug-Adapter, USB-Cable	50099 087
Other systems on request		

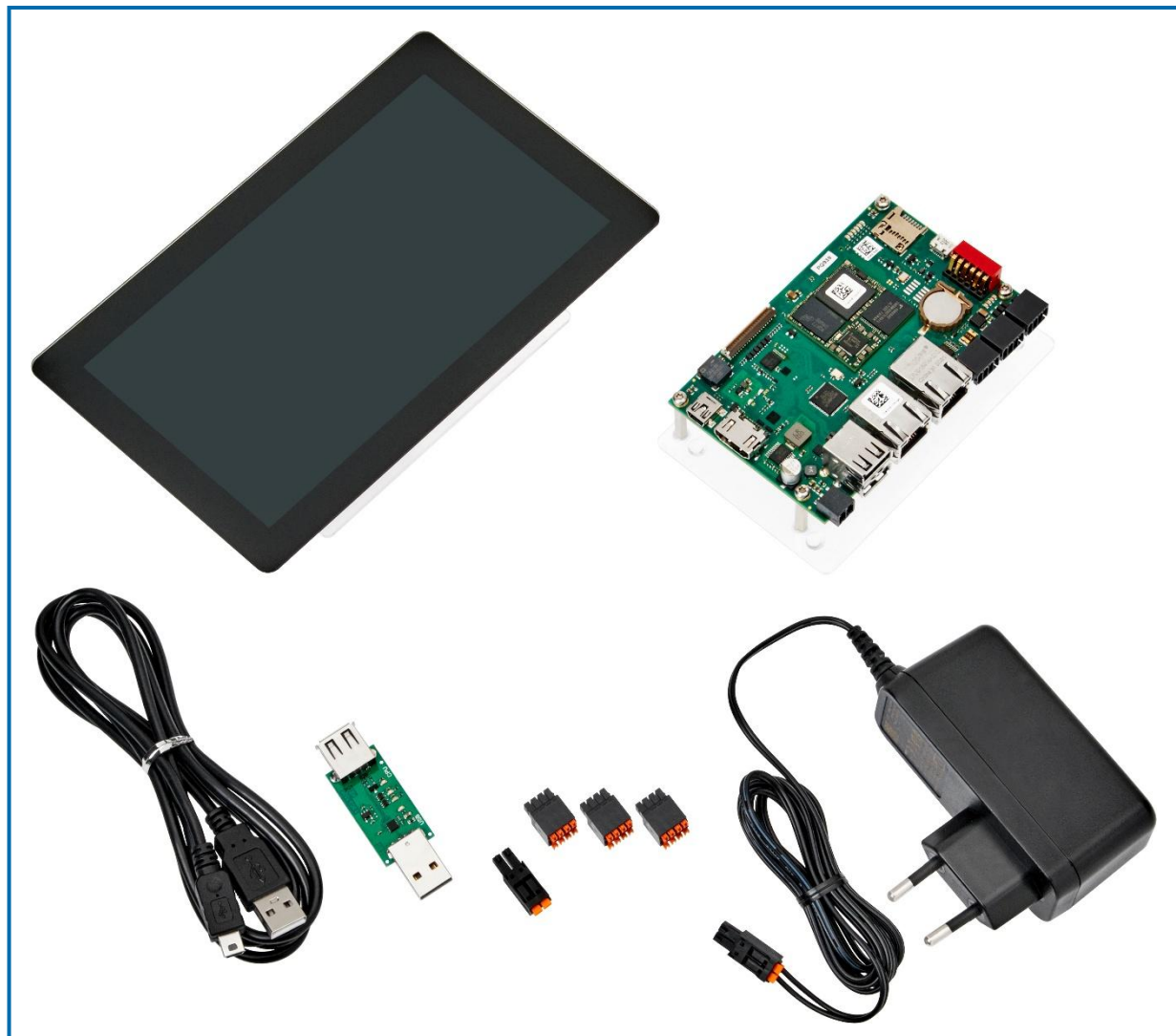

Figure 3: Development Kit DK i.MX8M Plus QC and DK 7" i.MX8M Plus QC

8.3 Related Products and Accessories

The following products are available with the i.MX8M Plus QC:

- OSM-S i.MX8M Plus QC (SoM-Line: Open Standard Module™ Size S)
- BL i.MX8M Plus QC (Board Line, including soldered-on OSM-S i.MX8M Plus)
- DK i.MX8M Plus QC (Development Kit, including BL i.MX8M Plus QC)
- DK 7" i.MX8M Plus QC (Development Kit, including BL i.MX8M Plus QC+ Touch-Display)
- AL i.MX8M Plus QC (Automation Line, including BL i.MX8M Plus QC + Housing)
- DL i.MX8M Plus QC (Display Line, including BL + 7" Touch-Display + Housing), project based only
- Other systems on request

Table 4: Accessories for BL i.MX8M Plus QC

Item	Description	Product Number
MicroSD Card	MicroSD Card 16 GB	1 060 0338
Power Supply	External power supply 230 V AC to 24 V DC / 18 W incl. 2-pin power connector (Phoenix Contact origin no. 1826680)	30099 001
Connector Set RS232/RS485/CAN/DIO mating connector	Connector set contains: <ul style="list-style-type: none"> ➤ 1x RS232: 8-pin; ➤ 1x RS485/CAN: 8-pin; ➤ 1x DIO: 8-pin (Phoenix Contact origin no. 1844594)	30099 006
USB-UART Debug-Adapter	Translates the UART signals provided on the Mini-B USB connector to USB for connecting the BL i.MX8M Plus QC to a computer	40099 101
USB-Cable	Connects the Mini-B Debug connector of the BL i.MX8M Plus QC to the USB-A of the Debug-Adapter	1 860 1154

9 System Specification

9.1 Technical Specification

The BL i.MX8M Plus QC implements the following technical specification.

Table 5: Technical Specification

Processor	<ul style="list-style-type: none"> ➤ MIMX8ML8CVNKZAB ➤ 4x Arm® Cortex®-A53 @1,6 GHz ➤ 1x Arm® Cortex®-M7 @800 MHz ➤ 2D and 3D graphics ➤ NPU with up to 2.3 TOPS
System Memory	<ul style="list-style-type: none"> ➤ 1 GByte up to 8 GByte LPDDR4 RAM
Storage	<ul style="list-style-type: none"> ➤ 4 GByte up to 128 GByte eMMC ➤ 8 kByte EEPROM ➤ 8 kByte EERAM nv Memory
Interfaces	<ul style="list-style-type: none"> ➤ 2x USB 2.0 Host, USB A ➤ 1x USB 3.0 Type-C DRP ➤ 1x Debug ➤ 2x 1 Gbit/s ➤ 1x HDMI ➤ 1x RS232 ➤ 1x RS485 ➤ 1x CAN FD ➤ 4x DIO (24 V DC / up to 800 mA) ➤ 1x LVDS (up to 1366 x 768 @60 fps) ➤ 1x MIPI CSI (4-lane)
Expansion Sockets	<ul style="list-style-type: none"> ➤ 1x MicroSD Card Slot ➤ 1x Extension Connector (SDIO 8-bit, I²C, SPI, SAI, USB, UART, PCIe, MIPI-CSI)
Power	<ul style="list-style-type: none"> ➤ 24 V DC ±20 % Input
Other Features	<ul style="list-style-type: none"> ➤ RTC with Coin Cell Battery CR1220 ➤ Buzzer

Table 6: Software Specification

Operating System (OS)	Yocto Linux BSP (demo) documentation and support: https://docs.kontron-electronics.de
-----------------------	---



Demo software

If the product is delivered with demo software, this software is intended for testing purposes only and is not permitted for real use!

9.2 Environmental Specification

Table 7: Environmental Conditions

Temperature (Operating)	0°C...55 °C ambient, non-condensing. Other temperature ranges on request.
Temperature (Storage)	-20...70 °C ambient, non-condensing
Pollution	Degree II



Cooling

The BL i.MX8M Plus QC is designed for operation in a customer-specific enclosure or device. Please do not operate the BL i.MX8M Plus QC without sufficient cooling system. The maximum temperature range refers only to the limits of the individual components. Do not place heat sources in close proximity to the product. This could otherwise lead to performance losses or an unexpected shutdown of the device.

9.3 Mechanical Specification

Table 8: Mechanical Specification

Dimension	BL i.MX8M Plus QC (Form Factor 4,3")
Width	105,5 mm (4,15")
Depth	67 mm (2,64")
Height	24 mm (0,94")
Weight	58 g (-0,13 lbs.)
Mounting	Screw mounting (M2.5)

Refer to the following outline dimensions drawing for more detailed mechanical information, including the position and size of the mounting holes. All dimensions are in millimeters.

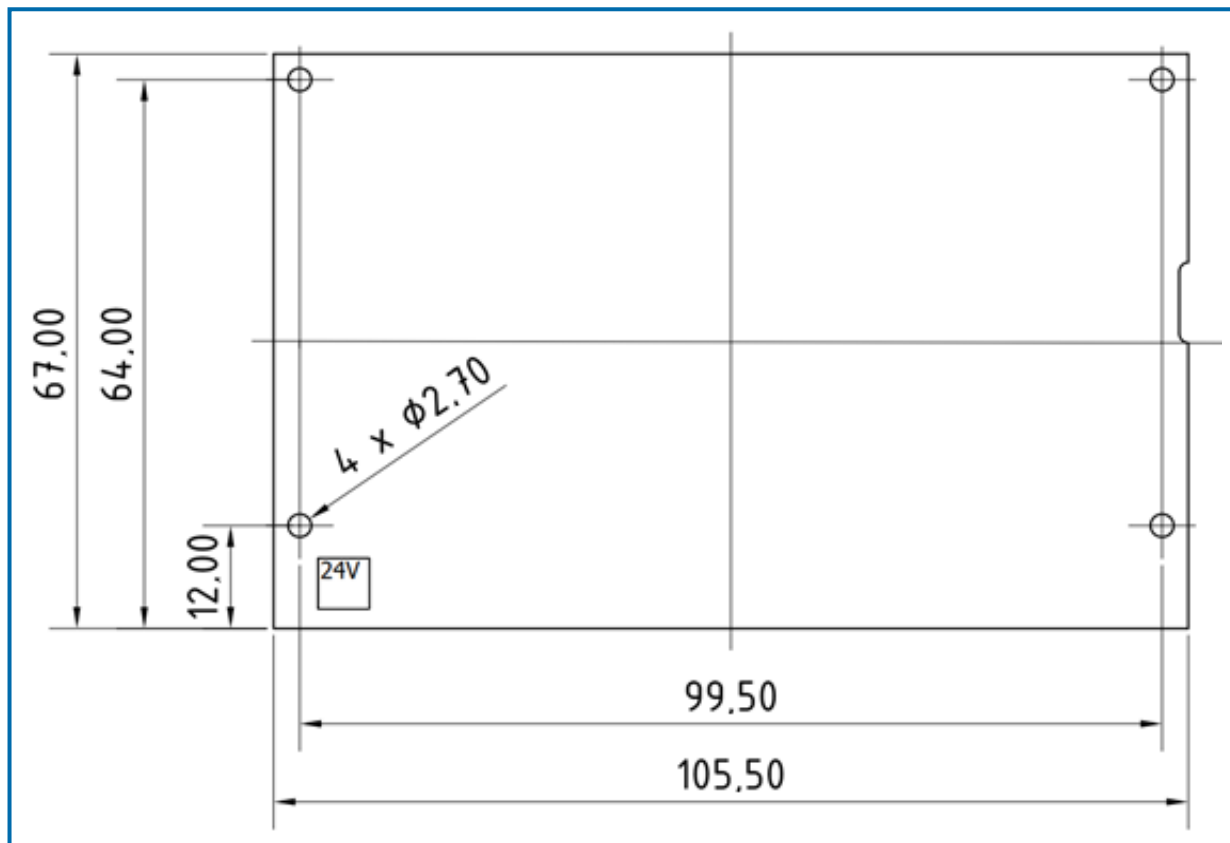

Figure 4: Board Dimensions

9.4 Power Specification

The BL i.MX8M Plus QC is powered by a 2-pin input power connector on the front and has no internal power supply. The standard input voltage of 24 V DC is converted internally to supply all other required voltages.



WARNING

The current of the power supply should be limited to 3 A.

Table 9: Power Specification

Nominal Input Voltage	24 V DC
Input Voltage Range	24 V DC \pm 20 %
Input Power	Max. 3 A
Output Current 3.3 V	1 A
Output Current 5 V	2 A
Output Current DOUT (24 V)	2.5 A
Input Power Mating Connector	2-pin Phoenix Contact 180° FMC 1,5/2-ST-3,5 (Phoenix 1826680)



Information

The CR1220 coin cell battery is solely used to power the real time clock (RTC) and has no function in the rest of the system's power supply.



Information

The power consumption of the BL i.MX8M Plus QC varies depending on the installed components and external peripherals, for more information see Table 10: Power Consumption



NOTICE

The maximum output current of all outputs together is divided between the 5 V and 3 V paths. The maximum output currents for 5 V and 3 V shown in Table 9 refer to the use of that voltage only and are reduced accordingly when both voltages are used.

Power Consumption

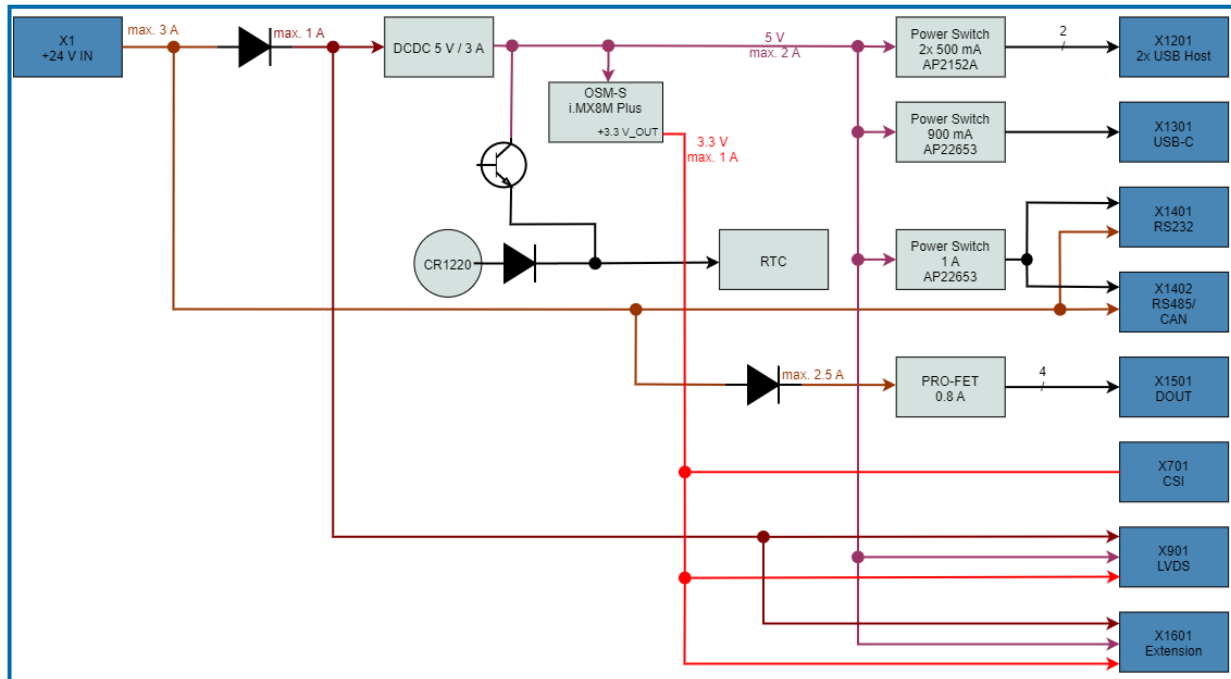

Figure 5: Power Tree

Table 10: Power Consumption

Power Figures	BL i.MX8M Plus QC
BL i.MX8M Plus QC idle	2,2 W
BL i.MX8M Plus QC KED Demo	2,5 W
BL i.MX8M Plus QC 100% CPU	3,9 W
1x LVDS	Backlight: $3.3\text{ V} * 1000\text{ mA} = 3.3\text{ W}$ or $5.0\text{ V} * 2000\text{ mA} = 10\text{ W}$ or $24\text{ V} * 300\text{ mA} = 7.2\text{ W}$
1x HDMI	$5\text{ V} * 50\text{ mA} = 0,25\text{ W}$
2x USB 2.0	$2x 5\text{ V} * 500\text{ mA} = 5\text{ W}$
1x USB-C	$5\text{ V} * 900\text{ mA} = 4.5\text{ W}$
DOUT	$2.5\text{ A} * 24\text{ V} = 60\text{ W}$

i.MX8M Plus power numbers are typical values based on typical silicon at 25 °C. Power numbers distributed to external devices are max. allowed values, partially overcurrent protected.



NOTICE

Please refer to NXP i.MX8M Plus Power Consumption Application Note for further details.

9.5 Earthing System

A functional earth connection to the board will be possible via the four mounting holes. These contact surfaces are directly attached to the electronic ground and the GND pin of the power connector.

9.6 Functional Block Diagram

The following diagram highlights the blue-colored interfaces, which are positioned along three edges of the board to allow easy access when mounted in an enclosure.

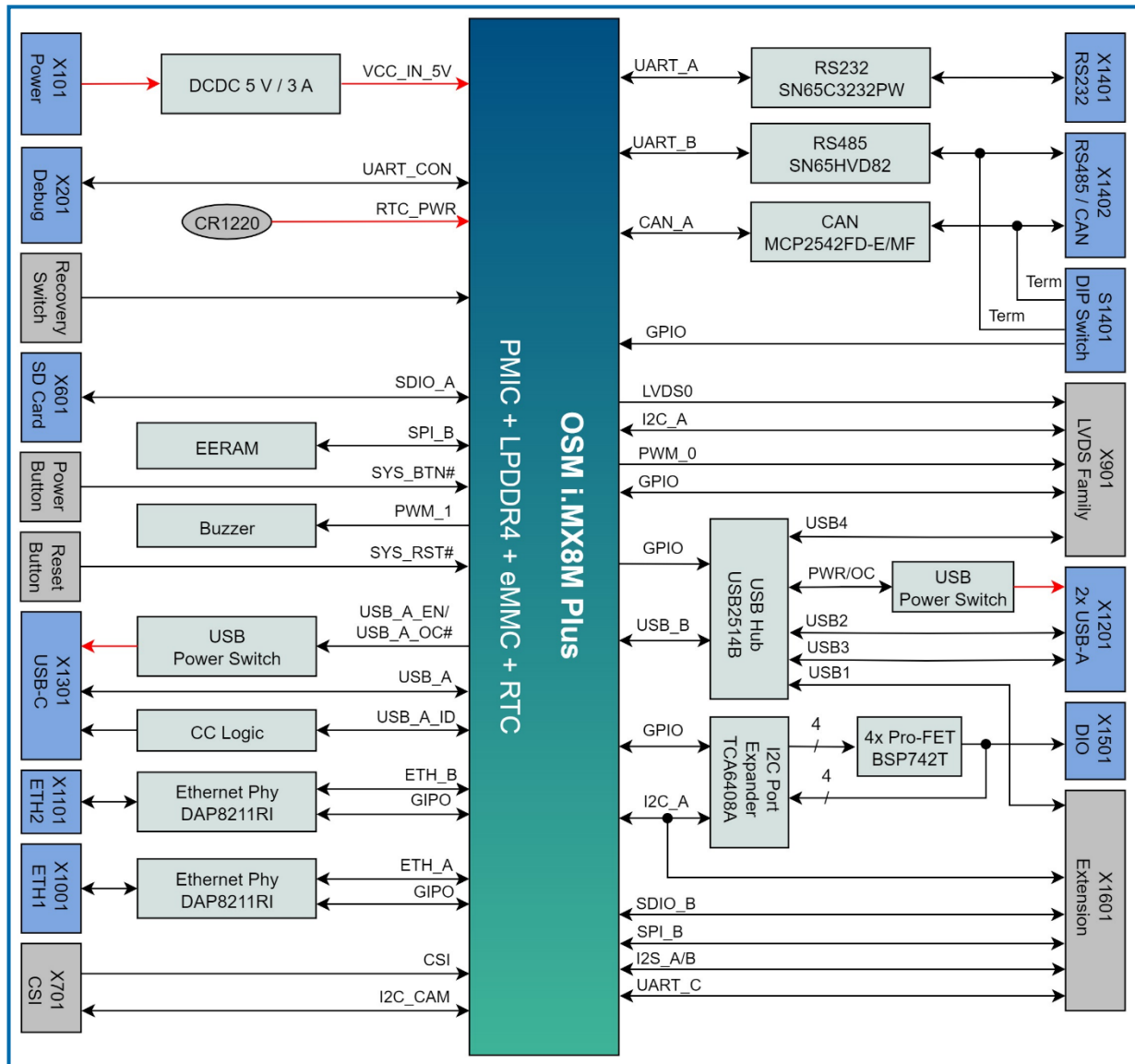

Figure 6: Block Diagram

9.7 Thermal Considerations



CAUTION hot Surface

There is a risk of injury from touching heated components or the board.

- Do not touch the board when the product is in operation.
- Allow the product to cool before handling.
- Wear protective gloves.
- Always turn the product off when not in use.

The BL i.MX8M Plus QC is a fanless and passively cooled system. When mounting the BL i.MX8M Plus QC in a housing take care not to obstruct the airflow over the components, as this stops sufficient heat dispersing into the ambient environment and causes a build-up of heat.



Information

The BL i.MX8M Plus QC is designed for operation in a customer-specific enclosure or device. Please do not operate the BL i.MX8M Plus QC without sufficient cooling system. The maximum temperature range refers only to the limits of the individual components.

9.8 Standards, Certifications and Directives

The BL i.MX8M Plus QC has been designed and tested in accordance with the following standards.



Information

If the user modifies the product, prerequisites for specific approvals such as CE conformity declaration (safety requirements) may no longer apply.

Table 11: Standards, Certifications and Directives Compliance

CE-Mark Compliant with EU Directives	Electromagnetic Compatibility	Directive 2014/30/EU
	RoHS directive	Directive 2011/65/EU + (EU)2015/863
EMC 2014/30/EU Immunity/ Emission	EN 61000-6-2:2019	Electromagnetic compatibility (EMC), part 6-2: Generic Standards- Immunity for industrial environment
	EN 61000-6-3:2021	Electromagnetic compatibility (EMC) - Part 6-3: Generic standards - Emission standard for residential, commercial and light-industrial environments

10 Board and Connectors

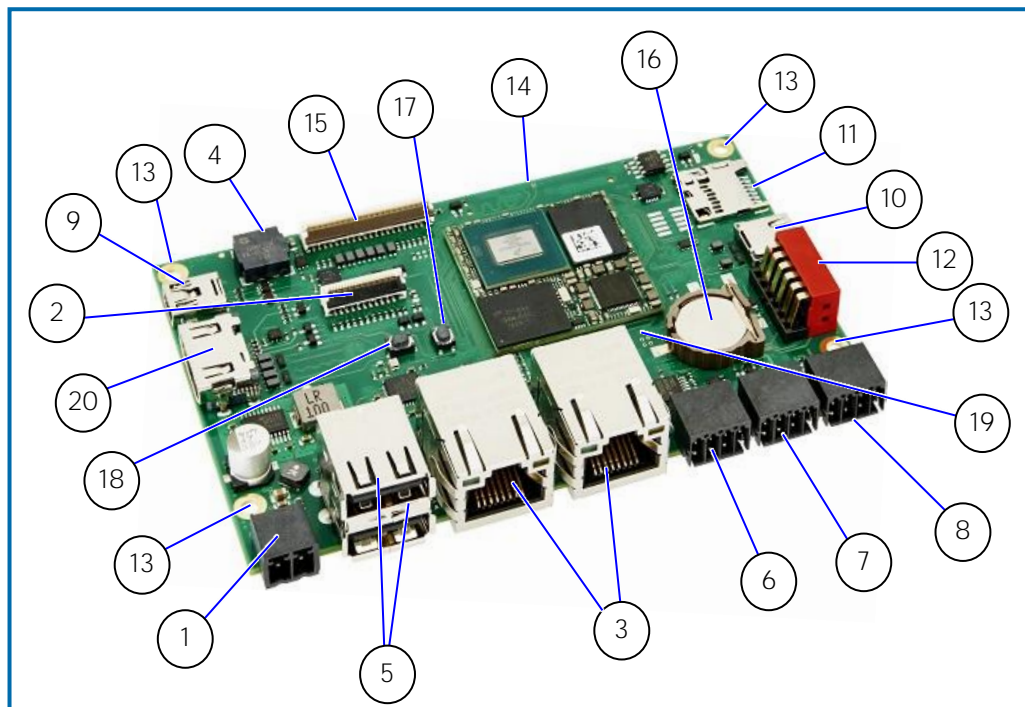

Figure 7: Top Side View

Table 12: Overview of Components and Connectors

Item	Label	Function	See Chapter
1	X101	DC Power Connector (2-pin Phoenix Contact)	10.1.1
2	X701	MIPI CSI Connector	10.1.2
3	X1101 + X1001	ETH RJ-45 LAN 2 / 1 Connector (left / right)	10.1.3
4	SM201	Buzzer	10.1.4
5	X1201	USB2.0 Port 0 / 1 Connector (upper / lower)	10.1.5
6	X1401	RS232 Connector	10.1.6
7	X1402	RS485 / CAN Connector	10.1.7
8	X1501	DIO Connector	10.1.9
9	X201	Debug UART Connector	10.1.10
10	X1301	USB-C Connector	10.1.11
11	X601	MicroSD Card Slot	10.1.12
12	S1401	CAN Address / Termination Switch	10.2.7
13	B101...B104	Functional Earth Connection	10.1.13
14	X1601 (bottom side)	Extension Connector	10.1.14
15	X901	LVDS Connector	10.1.15
16	E101	Coin Cell Battery Holder	12.4
17	S201	Power Button	10.1.16
18	S202	Reset Button	10.1.17
19	S1 (not visible)	Recovery Mode Switch	10.1.18
20	X801	HDMI Connector	10.1.19

10.1 Connector Details

10.1.1 Power Connector

There is one 2-pin power connector on the top side of the board supporting an input DC voltage range of 24 V DC $\pm 20\%$, see Figure 7 (pos. 1). The mating connector required to connect the power connector to a DC main power source is supplied with the BL i.MX8M Plus QC. For information on how to connect the supplied mating connector to the input power source, refer to Chapter 7.2: Wiring the DC Mating Power Connector.

For the pin assignment of the input power connector, refer to Chapter 10.2.1: Input Power Connector (X101).

10.1.2 MIPI CSI Interface

There is a 4-lane MIPI CSI interface (1080p @30 fps) for camera solutions, see Figure 7 (pos. 2).

For the pin assignment of the MIPI CSI connector, refer to Chapter 10.2.2: MIPI CSI Connector (X701)

10.1.3 Ethernet (LAN2, LAN1) Interface

There are two LAN ports, see Figure 7 (pos. 3). In the software these are referred to as ETH0 and ETH1. The assignment between LAN2/LAN1 and ETH0/ETH1 depends on the software. In order to achieve the specified performance of the Ethernet ports (1 Gbit/s), shielded category 5E, 6 or 6E twisted pair cables must be used. For the pin assignment of the RJ45 Ethernet connectors, refer to Chapter 10.2.3: Ethernet RJ45 Connector (X1001 + X1101)

10.1.4 Buzzer

There is a buzzer connected to PWM_1 (F18) via a N-channel MOSFET, see Figure 7 (pos. 4).

10.1.5 USB 2.0 Interface

There are two USB 2.0 ports allowing for the connection of USB 2.0 compatible devices, see Figure 7 (pos. 5). The USB ports are designed for connecting short cables only.

For the pin assignment of the USB 2.0 connector, refer to Chapter 10.2.4: USB Connector (X1201)

10.1.6 RS232 Interface

There is a RS232 interface (RX/TX) supporting RTS/CTS, see Figure 7 (pos. 6). The RS232 interface is not designed for connecting cables longer than 3 m.

For the pin assignment of the RS232 connector, refer to Chapter 10.2.5: RS232 Connector (X1401)

10.1.7 RS485 Interface

The RS485 interface in Figure 7 (pos. 7) contains also the wiring for CAN. The RS485 interface is not designed for connecting cables longer than 30 m.

For the pin assignment of the RS485/CAN connector, refer to Chapter 10.2.6: RS485/CAN Connector (X1402)

10.1.8 CAN Interface

The CAN interface in Figure 7 (pos. 7) also contains the wiring for RS485. The CAN address switches 1..4 are connected directly to GPIO pins and can therefore also be used for other purposes. The CAN interface is not designed for connecting cables longer than 30 m.

For the pin assignment of the RS485/CAN connector, refer to Chapter 10.2.6: RS485/CAN Connector (X1402)

10.1.9 DIO Interface

There is a four port DIO interface available on the front of the BL i.MX8M Plus QC, see Figure 7 (pos. 8).

The DIO pins consist of a 24 V high side switch, each capable of driving 800 mA. The voltage level is according to the supply voltage. When the output is disabled, the pin can be used as 24 V input.

The DIO interface is not designed for connecting cables longer than 30 m.

For the pin assignment of the DIO connector, refer to Chapter 10.2.8: DIO Connector (X1501)

10.1.10 Debug Interface

There is a debug interface using UART protocol with a Mini-B USB connector, see Figure 7 (pos. 9).

The debug interface is for service and should only be used by qualified personnel.

An additional adapter is needed to translate the UART signals provided on the Mini-B USB connector to USB. This adapter must be connected between an USB port on your computer and the debug interface on the BL i.MX8M Plus QC using a standard USB cable.

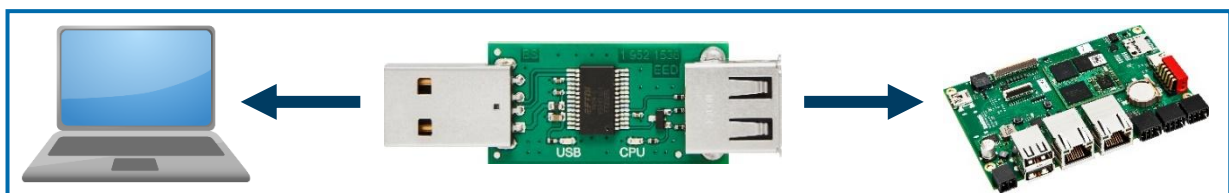

Figure 8: USB-UART Debug-Adapter

This adapter is only supplied as standard with our development kits but can also be ordered separately.

For more detailed information please have a look at the online documentation <https://docs.kontron-electronics.de>.

This documentation includes all information you need to put your device into operation including a quick start guide as well as further information on how to get access to the Yocto based GitLab software repository and how to make your own software images.

For the pin assignment of the debug connector, refer to Chapter 10.2.9: Debug Connector (X201)

10.1.11 USB-C Interface

There is a USB 3.0 Type-C DRP interface that can act as USB device or host, see Figure 7 (pos. 10).

The USB-C interface is for service and should only be used by qualified personnel.

For the pin assignment of the USB-C connector, refer to Chapter 10.2.10: USB-C Connector (X1301)

10.1.12 MicroSD Card Slot

There is a card slot to connect a microSD card for extra memory, see Figure 7 (pos. 11).

For the pin assignment of the microSD card slot, refer to Chapter 10.2.13: MicroSD Card Slot

For information on how to insert the microSD card slot, refer to Chapter 11.1: MicroSD Card Slot

10.1.13 Functional Earth Connection

The GND pin of the power connector is connected to functional earth of the electronics and to the four mounting holes on the edges of the circuit board, see Figure 7 (pos. 13).

10.1.14 Extension Connector

There is an extension connector for connecting customized add-on boards, see Figure 7 (pos. 14).

For the pin assignment of the extension connector, refer to Chapter 10.2.12: Extension Connector (X1601)



Pin Configuration

The pin assignment of the connector follows a typical configuration. Alternative pin assignments are possible in some cases through software multiplexing.

10.1.15 LVDS Interface

There is a LVDS interface to connect a LVDS display, see Figure 7 (pos. 15).

For the pin assignment of the LVDS connector, refer to Chapter 10.2.11: LVDS-Family Connector (X901).

10.1.16 Power Button

There is a Power Button to shut down the device, see Figure 7 (pos. 17).



CAUTION

The product is not disconnected from the power supply when it is switched off using the power button or the software.

10.1.17 Reset Button

There is a Reset Button to restart the device, see Figure 7 (pos. 18).

10.1.18 Recovery Mode Switch

There is a switch to activate or deactivate the recovery mode, see Figure 7 (pos. 19).

For more detailed information on how to use the recovery mode please have a look at the online documentation <https://docs.kontron-electronics.de>.

10.1.19 HDMI Interface

There is one HDMI interface (up to 4k resolution) for video solutions, see Figure 7 (pos. 20). The HDMI interface is not designed for connecting cables longer than 3 m. Depending on the monitor and the installation situation, a suitable HDMI cable with folding ferrite must be selected.

For the pin assignment of the HDMI connector, refer to Chapter 10.2.14 HDMI Connector (X801).

10.2 Connector Pin Assignments

10.2.1 Input Power Connector (X101)

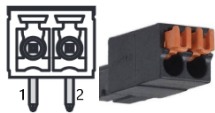
2-Pin Power Mating Connector	Pin	Signal Name
	1	VCC
	2	GND

Phoenix Contact Connector 180° FMC 1,5/2-ST-3,5 (Phoenix 1826680)

10.2.2 MIPI CSI Connector (X701)

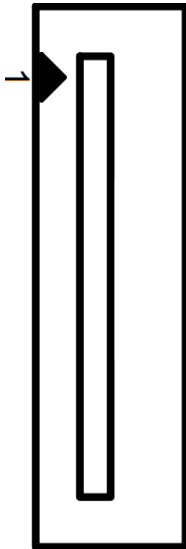
HDMI	Pin	Signal Name
	1	+3V3
	2	I2C_CAM_SDA_3V3
	3	I2C_CAM_SCL_3V3
	4	GND
	5	N.C.
	6	GPIO_B_3_3V3
	7	GND
	8	CSI_DATA3_P
	9	CSI_DATA3_N
	10	GND
	11	CSI_DATA2_P
	12	CSI_DATA2_N
	13	GND
	14	CSI_CLOCK_P
	15	CSI_CLOCK_N
	16	GND
	17	CSI_DATA1_P
	18	CSI_DATA1_N
	19	GND
	20	CSI_DATA0_P
	21	CSI_DATA0_N
	22	GND

10.2.3 Ethernet RJ45 Connector (X1001 + X1101)

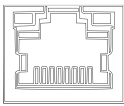
RJ45 (female)	Pin	Signal Name	Pin	Signal Name
	1	TX0+	5	TX2-
	2	TX0-	6	TX1-
	3	TX1+	7	TX3+
	4	TX2+	8	TX3-

Left LED: Activity / Link		Right LED: Activity 10/100/1000	
Off	10 Mbit/s	Off	No LAN connectivity
Green	100 Mbit/s, 1000 Mbit/s	Yellow	Link
		Blinking	Activity

10.2.4 USB Connector (X1201)

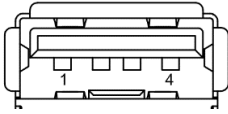
2x USB A 2.0	Pin	Signal Name
	1	+USB_VCC
	2	D-
	3	D+
	4	GND

10.2.5 RS232 Connector (X1401)

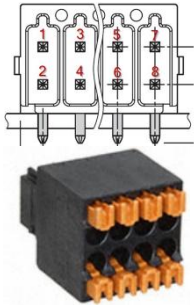
RS232 Interface	Pin	RS232
	1	VIN
	2	GND
	3	TxD
	4	RxD
	5	RTS
	6	CTS
	7	+5 V DC
	8	GND

Phoenix Contact Connector 180° DFMC 0,5/4-ST-2,54 (Phoenix 1844594)

10.2.6 RS485/CAN Connector (X1402)

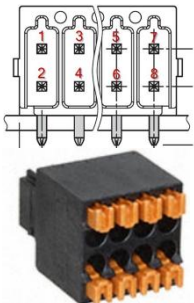
RS485/CAN Interface	Pin	Signal Name
	1	VIN
	2	GND
	3	RS485 A
	4	CAN H
	5	RS485 B
	6	CAN L
	7	+5 V DC
	8	GND

Phoenix Contact Connector 180° DFMC 0,5/4-ST-2,54 (Phoenix 1844594)

10.2.7 CAN Address and Termination Switch (S1401)

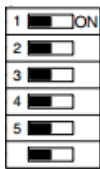
CAN Address	Switch	Signal Name
	1	Address 1
	2	Address 2
	3	Address 3
	4	Address 4
	5	CAN Termination (121 Ω)
	6	RS485 Termination (121 Ω)

10.2.8 DIO Connector (X1501)

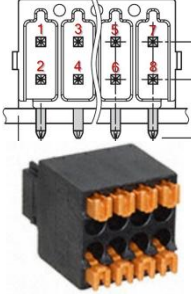
DIO Interface	Pin	Signal Name	Pin	Signal Name
	1	DOUT1 / DIN1 DOUT I _{max} = 800 mA	2	GND
	3	DOUT2 / DIN2 DOUT I _{max} = 800 mA	4	GND
	5	DOUT3 / DIN3 DOUT I _{max} = 800 mA	6	GND
	7	DOUT4 / DIN4 DOUT I _{max} = 800 mA	8	GND

Phoenix Contact Connector 180° DFMC 0,5/4-ST-2,54 (Phoenix 1844594)

10.2.9 Debug Connector (X201)

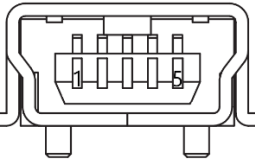
Mini-B USB Connector	Pin	Signal Name
	1	VCC
	2	RXD
	3	TXD
	4	N.C.
	5	GND

10.2.10 USB-C Connector (X1301)

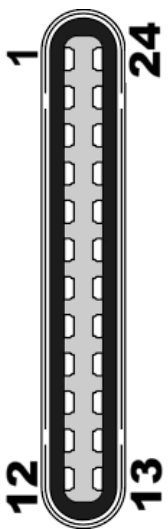
USB-C Connector	Pin	Signal Name	Pin	Signal Name
	1	GND	15	TX2-
	2	TX1+	16	VBUS
	3	TX1-	17	CC2
	4	VBUS	18	D2+
	5	CC1	19	D2-
	6	D1+	20	N.C.
	7	D1-	21	VBUS
	8	N.C.	22	RX1-
	9	VBUS	23	RX1+
	10	RX2-	24	GND
	11	RX2+	25	Shield
	12	GND	26	Shield
	13	GND	27	Shield
	14	TX2+	28	Shield

10.2.11 LVDS-Family Connector (X901)

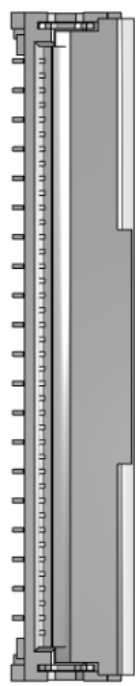
ZIF 40-pin	Pin	Signal Name	Pin	Signal Name
	1	VCC 3.3 V	21	RXIN3+
	2	VCC 3.3 V	22	GND
	3	VCC 3.3 V	23	USB_DN
	4	PWR_EN	24	USB_DP
	5	TFT_RESET (active low)	25	GND
	6	STBY (active low)	26	I2C_SDA
	7	GND	27	I2C_SCL
	8	RXINO-	28	TOUCH_INT
	9	RXINO+	29	TOUCH_RST
	10	GND	30	GND
	11	RXIN1-	31	+24 V
	12	RXIN1+	32	+24 V
	13	GND	33	SHLR (horizontal inversion)
	14	RXIN2-	34	UPDN (vertical inversion)
	15	RXIN2+	35	PWM
	16	GND	36	GND
	17	RXCLKIN-	37	GND
	18	RXCLKIN+	38	+5 V
	19	GND	39	+5 V
	20	RXIN3-	40	+5 V

Connector Type

X6: Molex ZIF-Buchse 501951-4010 (180° FPC 40 pol. RM0,5)

10.2.12 Extension Connector (X1601)

Hirose 80pol.	Pin	Signal Name	Pin	Signal Name
	1	+24 V	41	USBDM_EXT (USB-Hub)
	2	VDD_RTC	42	I2C1_SDA
	3	+24 V	43	USBDP_EXT (USB-Hub)
	4	GND	44	GPIO3_IO01
	5	+24 V	45	GND
	6	+3.3 V	46	GPIO3_IO02
	7	GND	47	PRTCTL_EXT (USB-Hub)
	8	+3.3 V	48	I2C3_SDA
	9	+5 V	49	CCM_CLK01
	10	GND	50	I2C3_SCL
	11	+5 V	51	MIPI_CSI2_CLK_P
	12	GND	52	GPIO3_IO00
	13	+5 V	53	MIPI_CSI2_CLK_N
	14	SD3_DATA0	54	GPIO3_IO16
	15	GND	55	GND
	16	SD3_DATA1	56	GND
	17	UART2_TXD	57	MIPI_CSI2_D0_P
	18	SD3_DATA2	58	ECSPI2_SSO
	19	UART2_RXD	59	MIPI_CSI2_D0_N
	20	SD3_DATA3	60	ECSPI2_SCLK
	21	GND	61	GND
	22	GND	62	ECSPI2_MISO
	23	GND	63	MIPI_CSI2_D1_P
	24	SD3_CMD	64	ECSPI2_MOSI
	25	PCIE_REF_PAD_CLK_P	65	MIPI_CSI2_D1_N
	26	SD3_CLK	66	SAI3_MCLK
	27	PCIE_REF_PAD_CLK_N	67	GND
	28	GND	68	SAI3_TXC
	29	GND	69	MIPI_CSI2_D2_P
	30	SD3_DATA4	70	SAI3_TXFS
	31	PCIE_RXN_P	71	MIPI_CSI2_D2_N
	32	SD3_DATA5	72	SAI3_RXD0
	33	PCIE_RXN_N	73	GND
	34	SD3_DATA6	74	GND
	35	GND	75	MIPI_CSI2_D3_P
	36	SD3_DATA7	76	SAI3_TXD0
	37	PCIE_TXN_P	77	MIPI_CSI2_D3_N
	38	GND	78	SAI3_RXD1
	39	PCIE_TXN_N	79	GND
	40	I2C1_SCL	80	SAI3_TXD1

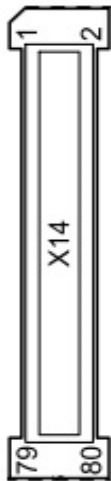

Connector Type X14: Hirose FX10A-80P/8-SV1(91)

10.2.13 MicroSD Card Slot (X601)

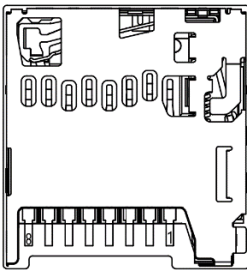
MicroSD Card	Pin	Signal Name
	1	DAT2
	2	CD/DAT3
	3	CMD
	4	VDD
	5	CLK
	6	GND
	7	DAT0
	8	DAT1
	14	DSW2



Information

Pay attention to the manufacturer's lifespan specification. Due to the limited lifespan of SD-Cards/SSD drives Kontron Electronics recommends checking the condition regularly.

10.2.14 HDMI Connector (X801)

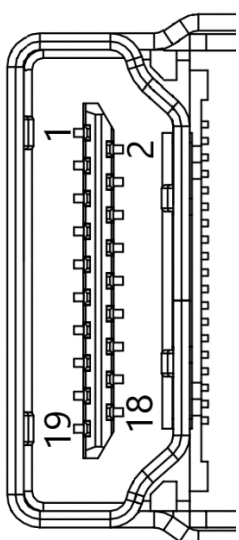
HDMI Connector	Pin	Signal Name
	1	TMDS Data2+
	2	GND
	3	TMDS Data2-
	4	TMDS Data1+
	5	GND
	6	TMDS Data1-
	7	TMDS Data0+
	8	GND
	9	TMDS Data0-
	10	TMDS Clock+
	11	GND
	12	TMDS Clock-
	13	Reserved
	14	Reserved
	15	DDC_CLK
	16	DDC_DATA
	17	GND
	18	+5 V Power
	19	Hot Plug Detect

11 Accessing Components and Extending the Device

This chapter contains important information that users must read before accessing components. Follow these procedures properly when accessing or installing component to extend the system.



CAUTION

The installation/removal of system components may only be performed by a qualified person. Please observe the "Safety Instructions" contained within this user guide.



ESD Sensitive Device

Follow the safety instructions for components that are sensitive to electrostatic discharge (ESD). Failure to observe this warning notice may result in damage to the product or/and internal components



Information

Because of the limited predetermined lifespan of expansion devices, Kontron Electronics recommends checking the condition of installed expansion devices regularly and to pay attention to the manufacturer specifications for lifespan.

11.1 MicroSD Card Slot

The BL i.MX8M Plus QC supports a removable microSD card.

To remove/install a removable microSD card, perform the following steps:

- Press the microSD card on the right-hand side of the BL i.MX8M Plus QC to remove a microSD card out of the slot.
- The microSD card automatically slides out a bit for removal.
- Slide in the microSD card, if needed. Take care of the correct position.

11.2 Extending the Device

- When installing additional modules, ensure that the workspace is clean.
- After installing the additional modules, please check the product for any damage.
- The power consumption of each additional module must not exceed the specified limit.
- Structural changes and modifications must be approved by Kontron Electronics. Unauthorised structural modifications and conversions will result in the loss of any warranty.
- Only trained personnel are authorised to handle and operate the device.

12 Storage, Transportation and Maintenance

12.1 Storage

If the product is not in use for an extended period time, disconnect the power. If it is necessary to store the product then re-pack the product as originally delivered to avoid damage. The storage facility must meet the products environmental requirements as stated within this user guide. Kontron Electronics recommends keeping the original packaging material for future storage or warranty shipments.

12.2 Transportation

To ship the product, use the original packaging, designed to withstand impact and adequately protect the product. When packing or unpacking products always take shock and ESD protection into consideration and use an EOS/ESD safe working area.

12.3 Maintenance

Maintenance or repair on the open product may only be carried out by qualified personnel authorized by Kontron Electronics.

Cleaning:

- For light soiling, clean the product with a dry cloth.
- Carefully remove dust from the surface of the chassis and cooling fins (if present) using a clean, soft brush.
- Stubborn dirt should be removed using a mild detergent and a soft cloth.



NOTICE

Do not use steel wool, metallic threads or solvents like abrasives, alcohol, acetone or benzene for cleaning the BL i.MX8M Plus QC.



WARNING

Keep the device dry. Exposure to water may cause damage to the device and pose a risk to the user.

12.4 Replacing the Coin Cell Battery

The coin cell battery (CR1220) must only be replaced with the same type of battery or with a type of battery recommended by Kontron Electronics. If the on-board Lithium battery needs to be replaced, follow the steps below:

- Remove the battery from the holder by pulling it outwards.
- Place a new battery in the battery holder.
- Pay attention to the polarity of the battery.



WARNING

Risk of explosion if the battery is not replaced in accordance with the instructions! (short circuit, reverse polarity, wrong type of battery) Dispose of used batteries in accordance with the manufacturer's instructions.

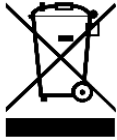

NOTICE

Do not dispose of coin batteries in general trash collection. Dispose of the battery according to the local regulations dealing with the disposal of these special materials, (e.g. to the collecting points for dispose of batteries).

13 Technical Support

13.1 First Steps – Startup Information Baseboard

For the first startup of the BL i.MX8M Plus QC, you will find more information and known issues about the software / BSP (demo) and additional hardware information at the online documentation.

Please follow the link: <https://docs.kontron-electronics.de>

The online documentation is primarily intended for our Development Kit but will help you also to put your BL i.MX8M Plus QC into operation. Additionally, you will find information how to get access to the Yocto based GitLab software repository and how to make your own software images.

Extended Support

For detailed technical support please contact:

E-Mail: support@kontron-electronics.de

Make sure you have the following product identification information in your e-mail:

- Product name
- Product model number
- Serial number (SN) of the unit

Please explain the nature of your problem in your e-mail.



Serial Number

The serial number can be found on the label on the system.

13.2 License Information

The demo software contained in the device (BSP) contains parts which were licensed as free respectively open-source software under the GNU General Public License, version 2 and/or 3, respectively the GNU Lesser General Public License, versions 2.1 and/or 3.0.

You can obtain a pre-configured demo image at <https://docs.kontron-electronics.de/> or contact:

Kontron Electronics GmbH
Max-Planck-Str. 6
72636 Frickenhausen
Germany

Web: www.kontron-electronics.com

E-Mail: support@kontron-electronics.de

14 Product Usage Life Cycle

14.1 Warranty

Kontron Electronics defines product warranty in accordance with regional warranty definitions. Claims are at Kontron Electronics discretion and limited to the defect being of a material nature. To find out more about the warranty conditions and the defined warranty period for your region, following the steps below:

1. Visit Kontron Electronics Term and Conditions webpage

www.kontron-electronics.com/downloads/

2. Click on the relevant document

Limitation/Exemption from Warranty Obligation

In general, Kontron Electronics shall not be required to honor the warranty, even during the warranty period, and shall be exempted from the statutory accident liability obligations in the event of damage caused to the product due to failure to observe the following:

- Safety instructions within this user guide
- Warning labels on the product and warning symbols within this user guide
- Information and hints within this user guide

Additionally, alterations or modifications to the product that are not explicitly approved by Kontron Electronics, described in this user guide, or received from Kontron Electronics Support as a special handling instruction will void your warranty.

Within the warranty period, the product should only be opened by Kontron Electronics. Removing the protection label and opening the product within the warranty period exempts the product from the statutory warranty obligation.

Due to their limited service life, parts which by their nature are subject to a particularly high degree of wear (wearing parts) are excluded from the warranty beyond that provided by law.

14.2 Quality and Environmental Management

Kontron Electronics aims to deliver reliable high-end products designed and built for quality, and aims to complying with environmental laws, regulations, and other environmentally oriented requirements. For more information regarding Kontron Electronics' quality and environmental responsibilities, visit www.kontron-electronics.com/company/about-us/germany/

14.3 Disposal and Recycling

Kontron Electronics' products are manufactured to satisfy environmental protection requirements where possible. Many of the components used are capable of being recycled. Final disposal of this product after its service life must be accomplished in accordance with applicable country, state, or local laws or regulations.

14.4 WEEE Compliance

The Waste Electrical and Electronic Equipment (WEEE) Directive aims to:

- Reduce waste arising from electrical and electronic equipment (EEE).
- Make producers of EEE responsible for the environmental impact of their products, especially when the product becomes waste.
- Encourage separate collection and subsequent treatment, reuse, recovery, recycling and sound environmental disposal of EEE.
- Improve the environmental performance of all those involved during the lifecycle of EEE.



Environmental Protection

Environmental protection is a high priority with Kontron Electronics.
Kontron Electronics follows the WEEE directive.
You are encouraged to return our products for proper disposal.

15 Appendix

List of Acronyms

Table 13: List of Acronyms

Acronym	Description	Acronym	Description
AC	Alternating Current	HD/HDD	Hard Disk /Drive
AIN	Analog Input	HDMI	High-Definition Multimedia Interface
AL	Automation Line (Board with housing)	HPM	PICMG Hardware Platform Management specification family
BL	Board Line (Board without housing)	H/W	Hardware
BSP	Board Support Package (Software)	IEC	International Electrotechnical Commission (Standards)
CAN	Controller Area Network (BUS)	IOL	IPMI-Over-LAN
CPI	Advanced Configuration Control Interface	IOT	Internet of Things
CPU	Central Processing Unit	KVM	Keyboard Video Mouse
CSI	Camera Serial Interface	LAN	Local Area Network
DC	Direct Current	LED	Light Emitting Device / Diode
DIN	Deutsches Institut für Normung, German Institute for Standardization (Standards)	LPDDR	Low-Power Double Data Rate (RAM)
DIO	Digital Input/Output	LVD	Low Voltage Device
DK	Development Kit	M.2	Next smaller generation of mSATA
DL	Display Line (Board with Display)	MEI	Management Engine Interface
DOUT	Digital Output	mPCIe	Mini PCI-Express
DP	Display Port	mSATA	Mini SATA
DSI	Display Serial Interface	OS	Operating System
ECC	Error Checking and Correction	PCIe	PCI-Express
EEE	Electrical and Electronic Equipment	RAM	Read Access Memory
EHCI	Enhanced Host Controller Interface	REV	Revision
EMC	Electromagnetic Compatibility	RoHS	Restriction of the use of certain hazardous substances
eMMC	Embedded MultiMediaCard	ROM	Read-only memory
EN	European Norm (Standards)	RTC	Real Time Clock
ESD	Electrostatic Discharge	SATA	Serial-ATA
ETH	Ethernet (LAN)	SEL	System Event Log
GbE	Gigabit Ethernet	SELV	Safety Extra Low Voltage
GPIO	General-Purpose Input/Output	SIO	Super Input/output

Acronym	Description	Acronym	Description
GPU	Graphics Processing Unit	SMBus	System Management Bus
SMWI	System Monitor Web Interface	USB	Universal Serial Bus
SN	Serial Number	USB OTG	USB On-The-Go (Host)
SOL	Serial Over LAN	uSD	microSD (Memory Card)
SSD	Solid State Drive	VGA	Video Graphics Array
TPM	Trusted Platform Module	VLP	Very Low Profile
UEFI	Unified Extensible Firmware Interface	WEEE	Waste Electrical and Electronic Equipment
uHDMI	Micro-HDMI	WLAN	Wireless LAN
UL	Underwriters Laboratories (Standards)	XHCI	eXtensible Host Controller Interface

"List of Acronyms"



About Kontron

Kontron AG is a leading IoT technology company. For more than 20 years, Kontron has been supporting companies from a wide range of industries to achieve their business goals with intelligent solutions. From automated industrial operations, smarter and safer transport to advanced communications, connectivity, medical, and energy solutions, the company delivers technologies that add value for its customers. With the acquisition of Katek SE in early 2024, Kontron significantly strengthens its portfolio with the new GreenTec division, focusing on solar energy and eMobility, and grows to around 8,000 employees in over 20 countries worldwide. Kontron is listed on the SDAX® and TecDAX® of the German Stock Exchange.

For more information, please visit: www.kontron.com

About Kontron Electronics

Kontron Electronics GmbH is a full-service provider in the field of electronics, development and manufacturing services. Our business portfolio includes proprietary and client-specific products, development and design services for complex electronics components, modules and systems, as well as production and assembly services for entire devices. The company is part of the technology corporation Kontron AG.

For more information, please visit: www.kontron-electronics.com

Your Contact

Kontron Electronics GmbH

Max-Planck-Straße 6
72636 Frickenhausen, Germany
Tel.: +49 7022 4057-0
info@kontron-electronics.de
www.kontron-electronics.com

Global Headquarters

Kontron Europe GmbH

Gutenbergstraße 2
85737 Ismaning, Germany
Tel.: +49 821 4086-0
info@kontron.com
www.kontron.com