

# SL iMX8MM

Doc. Rev. 1.2

This page has been intentionally left blank

 SL IMX8MM - USER GUIDE

## Disclaimer

Kontron Electronics would like to point out that the information contained in this user guide may be subject to alteration, particularly as a result of the constant upgrading of Kontron Electronics products. This document does not entail any guarantee on the part of Kontron Electronics with respect to technical processes described in the user guide or any product characteristics set out in the user guide. Kontron Electronics assumes no responsibility or liability for the use of the described product(s), conveys no license or title under any patent, copyright or mask work rights to these products and makes no representations or warranties that these products are free from patent, copyright or mask work right infringement unless otherwise specified. Applications that are described in this user guide are for illustration purposes only. Kontron Electronics makes no representation or warranty that such application will be suitable for the specified use without further testing or modification. Kontron Electronics expressly informs the user that this user guide only contains a general description of processes and instructions which may not be applicable in every individual case. In cases of doubt, please contact Kontron.

This user guide is protected by copyright. All rights are reserved by Kontron. No part of this document may be reproduced, transmitted, transcribed, stored in a retrieval system, or translated into any language or computer language, in any form or by any means (electronic, mechanical, photocopying, recording, or otherwise), without the express written permission of Kontron. Kontron Electronics points out that the information contained in this user guide is constantly being updated in line with the technical alterations and improvements made by Kontron Electronics to the products and thus this user guide only reflects the technical status of the products by Kontron Electronics at the time of publishing.

Brand and product names are trademarks or registered trademarks of their respective owners.

©2021 by Kontron Electronics GmbH

Kontron Electronics GmbH

Kantstr. 10  
72663 Großbottlingen  
Germany  
[www.kontron-electronics.de](http://www.kontron-electronics.de)

Kontron Europe GmbH

Gutenbergstr. 2  
85737 Ismaning  
Germany  
[www.kontron.com](http://www.kontron.com)

## Intended Use

THIS DEVICE AND ASSOCIATED SOFTWARE ARE NOT DESIGNED, MANUFACTURED OR INTENDED FOR USE OR RESALE FOR THE OPERATION OF NUCLEAR FACILITIES, THE NAVIGATION, CONTROL OR COMMUNICATION SYSTEMS FOR AIRCRAFT OR OTHER TRANSPORTATION, AIR TRAFFIC CONTROL, LIFE SUPPORT OR LIFE SUSTAINING APPLICATIONS, WEAPONS SYSTEMS, OR ANY OTHER APPLICATION IN A HAZARDOUS ENVIRONMENT, OR REQUIRING FAIL-SAFE PERFORMANCE, OR IN WHICH THE FAILURE OF PRODUCTS COULD LEAD DIRECTLY TO DEATH, PERSONAL INJURY, OR SEVERE PHYSICAL OR ENVIRONMENTAL DAMAGE (COLLECTIVELY, "HIGH RISK APPLICATIONS").

You understand and agree that your use of Kontron Electronics devices as a component in High Risk Applications is entirely at your risk. To minimize the risks associated with your products and applications, you should provide adequate design and operating safeguards. You are solely responsible for compliance with all legal, regulatory, safety, and security related requirements concerning your products. You are responsible to ensure that your systems (and any Kontron Electronics hardware or software components incorporated in your systems) meet all applicable requirements. Unless otherwise stated in the product documentation, the Kontron Electronics device is not provided with error-tolerance capabilities and cannot therefore be deemed as being engineered, manufactured or setup to be compliant for implementation or for resale as device in High Risk Applications. All application and safety related information in this document (including application descriptions, suggested safety measures, suggested Kontron Electronics products, and other materials) is provided for reference only.

## Revision History

Revision	Brief Description of Changes	Date of Issue	Author /Editor
0.1	Basic draft	2019-September-19	Gb
1.0	Release Version Modification general sections; Updated Block-diagram and pinout	2020-January-27	Gb/KI
1.1	Added information in chapter 5.3.2 Corrected typo for pin V14 Added signal NVCC_SD to B8	2020-October-06	Gb
1.2	New address Kontron Headquarter	2021-January-27	KI

## Customer Support

Find Kontron Electronics contacts by visiting: <http://www.kontron-electronics.de>.

## Customer Comments

If you have any difficulties using this user guide, discover an error, or just want to provide some feedback, contact [support@kontron-electronics.de](mailto:support@kontron-electronics.de). Detail any errors you find. We will correct the errors or problems as soon as possible and provide the revised user guide.

## Symbols

The following symbols may be used in this user guide

### **⚠ DANGER**

DANGER indicates a hazardous situation which, if not avoided, will result in death or serious injury.

### **⚠ WARNING**

WARNING indicates a hazardous situation which, if not avoided, could result in death or serious injury.

### **NOTICE**

NOTICE indicates a property damage message.

### **⚠ CAUTION**

CAUTION indicates a hazardous situation which, if not avoided, may result in minor or moderate injury.



#### **Electric Shock!**

This symbol and title warn of hazards due to electrical shocks (> 60 V) when touching products or parts of products. Failure to observe the precautions indicated and/or prescribed by the law may endanger your life/health and/or result in damage to your material.



#### **ESD Sensitive Device!**

This symbol and title inform that the electronic boards and their components are sensitive to static electricity. Care must therefore be taken during all handling operations and inspections of this product in order to ensure product integrity at all times.



#### **HOT Surface!**

Do NOT touch! Allow to cool before servicing.



#### **Laser!**

This symbol inform of the risk of exposure to laser beam and light emitting devices (LEDs) from an electrical device. Eye protection per manufacturer notice shall review before servicing.



This symbol indicates general information about the product and the user guide.

This symbol also indicates detail information about the specific product configuration.



This symbol precedes helpful hints and tips for daily use.

## Special Handling and Unpacking Instruction

**NOTICE****ESD Sensitive Device!**

Electronic boards and their components are sensitive to static electricity. Therefore, care must be taken during all handling operations and inspections of this product, in order to ensure product integrity at all times.

Do not handle this product out of its protective enclosure while it is not used for operational purposes unless it is otherwise protected.

Whenever possible, unpack or pack this product only at EOS/ESD safe work stations. Where a safe work station is not guaranteed, it is important for the user to be electrically discharged before touching the product with his/her hands or tools. This is most easily done by touching a metal part of your system housing.

It is particularly important to observe standard anti-static precautions when changing piggybacks, ROM devices, jumper settings etc. If the product contains batteries for RTC or memory backup, ensure that the product is not placed on conductive surfaces, including anti-static plastics or sponges. They can cause short circuits and damage the batteries or conductive circuits on the product.

## Quality and Environmental Management

Kontron aims to deliver reliable high-end products designed and built for quality, and aims to complying with environmental laws, regulations, and other environmentally oriented requirements.

For more information regarding Kontron's quality and environmental responsibilities, visit <https://www.kontron-electronics.de/unternehmen/qualitaet/>.

## Table of Contents

Symbols .....	6
Special Handling and Unpacking Instruction .....	7
Quality and Environmental Management .....	7
Table of Contents .....	8
List of Tables .....	8
List of Figures .....	9
1/ Introduction.....	10
2/ Description.....	11
2.1. Product Variants and Accessories.....	12
3/ System Specifications.....	13
3.1. Component Main Data.....	13
3.2. Environmental Conditions.....	14
3.3. Functional Block Diagram.....	15
4/ Board and Connectors.....	16
4.1.1. Connectors .....	16
4.2. SoM view and locations .....	16
4.3. Bottom Side .....	17
4.4. Mechanical Drawings.....	18
4.5. Pinout diagram of SL iMX8MM .....	20
4.5.1. Pinout of SL iMX8MM .....	21
5/ Installation.....	28
5.1. Power Control.....	28
5.1.1. Power Supply.....	28
5.1.2. Supply voltage .....	28
5.1.3. Supply current.....	29
5.2. Reset pin .....	29
5.3. Boot Mode .....	29
5.3.1. SD/MMC manufacture mode .....	29
5.3.2. Serial Downloader .....	29
5.4. SD card.....	30
6/ Thermal considerations.....	31
7/ Reflow profile.....	32
8/ Technical Support.....	33
8.1. First Steps – Startup-Information Baseboard.....	33
8.2. Extended Support.....	33
8.3. Disclaimer & License Information .....	33
About Kontron Electronics .....	34

## List of Tables

Table 1: Product Variants of SL iMX8MM.....	12
Table 2: Component Main Data.....	13
Table 3: Environmental Conditions.....	14
Table 4: Connectors of SL iMX8MM.....	16
Table 5: Pinout of SL iMX8MM .....	21
Table 6: Supply voltage .....	28
Table 7: Supply current.....	29
Table 8: Boot mode pin settings .....	29
Table 9: Reflow profile.....	32

## List of Figures

Figure 1: 30x30mm SoM with LGA package .....	11
Figure 2: Block Diagram .....	15
Figure 3: Top View.....	16
Figure 4: Bottom View .....	17
Figure 5: Dimensions of SL iMX8MM .....	18
Figure 6: Footprint Grid.....	18
Figure 7: Keep out area on baseboard (top view).....	19
Figure 8: pin assignment (top view).....	20
Figure 9: power supply scheme.....	28
Figure 10: SD-Card connection example.....	30
Figure 11: Reflow Classification Profile .....	32

## 1/ Introduction

This user guide describes the 30mmx30mm SoM form factor module - SL iMX8MM . The Advanced RISC Machines (ARM) based module is equipped with NXP i.MX8M Mini processor. The quad core SoC takes advantage of the optimized power consumption and performance ratio.

The use of this user guide implies a basic knowledge of PC hardware and software. This user guide is focused on describing the special features and is not intended to be a standard PC textbook. New users are recommended to study the short installation procedure, before switching on the power.

All configuration and setup of the module is performed using the u-Boot CLI.

Latest revision of this user guide, datasheet, and BSPs (Board Support Packages) can be downloaded from Kontron Electronics Web Page.

## 2/ Description

The SL iMX8MM is a very small System-on-Module (SoM) using NXP's i.MX8M Mini processor with ARM Quad Cortex A53 and Cortex M4. The SL iMX8MM is a highly integrated, small sized module for integration in embedded systems with 30mmx30mm footprint.

The complexity of the DDR4 memory, power management and processor connection are contained in the 10-layer SOM and simplifies baseboard development.

Figure 1: 30x30mm SoM with LGA package

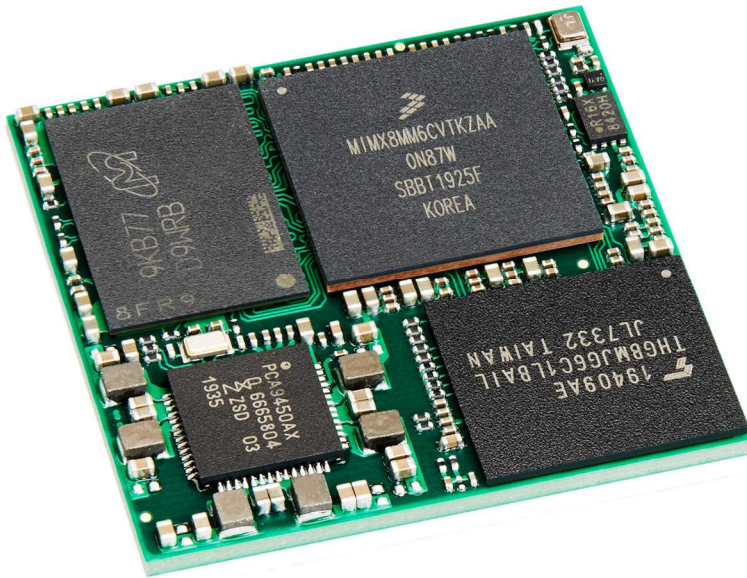

Main characteristics of the SL iMX8MM are:

- ▶ quad Arm® Cortex®-A53 core with up to 1.6 GHz and Cortex®-M4 400 MHz core processor is for low-power processing
- ▶ Up to 4 GB LPDDR4 memory down
- ▶ 4 to 64 GB eMMC
- ▶ 2 MB QSPI boot flash
- ▶ 2D GPU and 3D GPU (1x shader, OpenGL ES 2.0)
- ▶ 1x MIPI DSI (4-lane) with PHY
- ▶ 1x MIPI CSI (4-lane) with PHY
- ▶ Video Playback with 1080p60
- ▶ 2x USB 2.0 OTG controllers with integrated PHY
- ▶ 1x Gigabit Ethernet (MAC) with AVB and IEEE 1588, Energy Efficient Ethernet (EEE) for low power
- ▶ 1x PCIe 2.0 (1-lane) with L1 low power substates
- ▶ 5x SAI (12Tx + 16Rx external I2S lanes), 8ch PDM input
- ▶ 3x SDIO
- ▶ 4x UART
- ▶ 4x I2C
- ▶ 3x SPI

Please keep in mind, that not all interfaces are available simultaneously due to the amount of port pins and multiple multiplexing possibilities.

## 2.1. Product Variants and Accessories

### Order Informations:

Table 1: Product Variants of SL iMX8MM

Board	Description	Product Number
<b>SL iMX8MM Quad 1GB/8GB -25...+85°C</b>	SoM with NXP I.MX8M MINI processor, 1 GB LPDDR4 and 8 GB eMMC	40099 175
<b>SL iMX8MM Quad 2GB/8GB -25...+85°C</b>	SoM with NXP I.MX8M MINI processor, 2 GB LPDDR4 and 8 GB eMMC	40099 185
<b>SL iMX8MM Quad 4GB32GB -25...+85°</b>	SoM with NXP I.MX8M MINI processor, 4 GB LPDDR4 and 32 GB eMMC	40099 212

Table 2: Development Kits of SL iMX8MM

Board	Description	Product Number
<b>DK iMX8MM Quad 1GB/8GB</b>	SL iMX8MM Quad 1GB/8GB, BL iMX8MM Quad 1GB/8GB, Power Supply, Cable, Debug-Adapter	50099 059
<b>DK 7" iMX8MM Quad 1GB/8GB</b>	SL iMX8MM Quad 1GB/8GB, BL iMX8MM Quad 1GB/8GB, Displ., Touch, Pow. Sup, Cable, Debug-Ad	50099 063

## 3/ System Specifications

### 3.1. Component Main Data

The table below summarizes the features of the SoM.

Table 2: Component Main Data

SL I.MX8M MINI	
Form factor	30x30mm with 256 LGA pads
Processor	NXP's MIMX8MM6CVTKZAAwith 14mm x 14mm BGA package in 0.5mm pitch (industrial version)
Memory	1.6 GHz 32-bit LPDDR4 <ul style="list-style-type: none"> <li>▶ 1 GByte: 1x 8 Gbit density 256 M x32 LPDDR4 parts</li> <li>▶ 2 GByte: 1x 16 Gbit density 512 M x32 LPDDR4 parts</li> </ul>
Boot Flash	2 MB SPI NOR flash in USON (2x3mm) package connected on ECSP11
Bootloader/BIOS	U-Boot Bootloader
embedded Multimedia Card (eMMC)	4 to 64 GB MLC (Multi-level Cell) connected on SD1
Display	<ul style="list-style-type: none"> <li>▶ 1x MIPI DSI (4-lane) with PHY</li> <li>▶ Resolution: up to Full-HD 1080p @60 fps</li> </ul>
Onboard Controllers	
Ethernet Controller	<ul style="list-style-type: none"> <li>▶ Gigabit Ethernet controller with support for Energy Efficient Ethernet (EEE), Ethernet AVB, and IEEE 1588, no phy on SoM</li> </ul>
Watchdog Timer	CPU internal watchdog, configurable timeout counter with timeout periods from 0.5 to 128 seconds
System Management Controller	No dedicated System Management Controller on module System settings can be arranged in U-Boot environment variables
H/W Status Monitor	CPU internal temperature monitoring sensor
Power management	PCA9450AHN from NXP
Operating System Support	Linux Yocto
Default Interfaces	
I2C	4x
LAN, USB	1x Gigabit Ethernet, 2x USB 2.0 OTG
Display	1x MIPI DSI (4-lane) with up to 1920 x 1080 @60fps
SD-Card	2x SDIO (1x 4bit, 1x 8bit)
UART	4x
GPIO	27x
PWM	3x

other Connectivity	<ul style="list-style-type: none"> <li>▶ 1x SAI</li> <li>▶ 2x SPI</li> <li>▶ 1x PCIe</li> <li>▶ 1x QSPI</li> </ul>
<b>Power</b>	
Consumption	Maximum Power consumption of the board is measured to <3,5 W
Input Voltage	Single Supply 5V ±5%

### 3.2. Environmental Conditions

Table 3: Environmental Conditions

Operating	<ul style="list-style-type: none"> <li>▶ industrial: -25°C to 85°C</li> <li>▶ relative humidity (non-condensing) 10 % to 93 % at 40°C</li> </ul>
Storage	<ul style="list-style-type: none"> <li>▶ commercial grade: -40°C to +85°C</li> <li>▶ relative humidity (non-condensing) 10 % to 93 % at 40°C</li> </ul>

### 3.3. Functional Block Diagram

The block diagram shows a detailed structure of the SL iMX8MM module.

Figure 2: Block Diagram

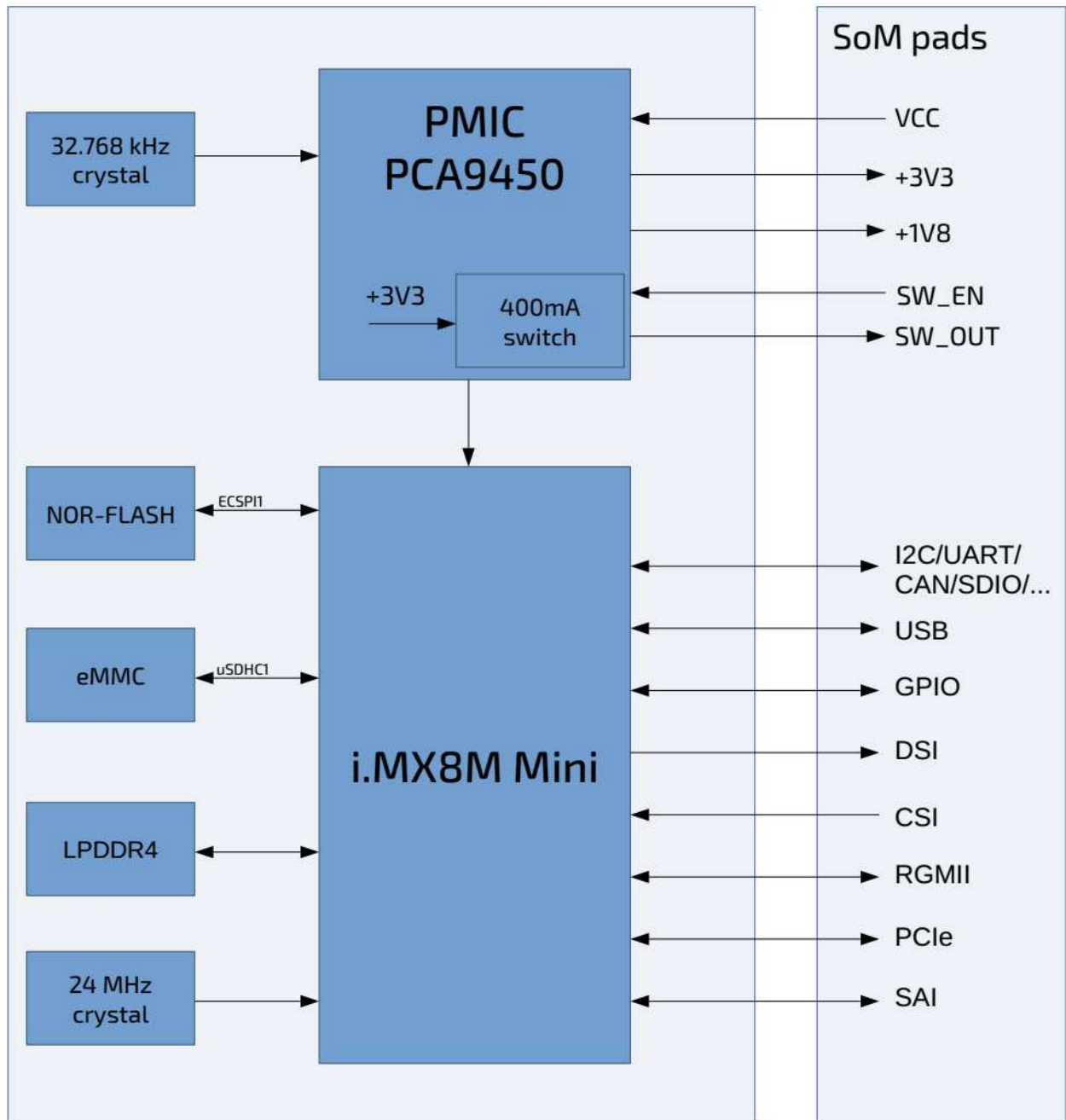

## 4/ Board and Connectors

### 4.1.1. Connectors

Table 4: Connectors of SL iMX8MM

Connector	Function	Remark
LGA package	Central Interface	solderable

### 4.2. SoM view and locations

Figure 3: Top View

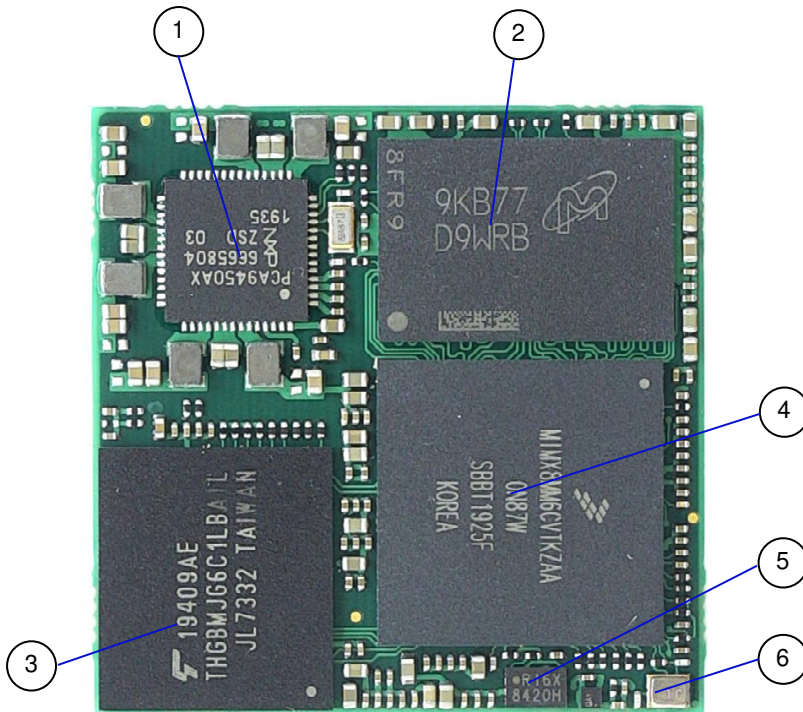

1. PMIC
2. LPDDR4
3. eMMC
4. i.MX8M Mini
5. NOR-Flash
6. Crystal

## 4.3. Bottom Side

Figure 4: Bottom View

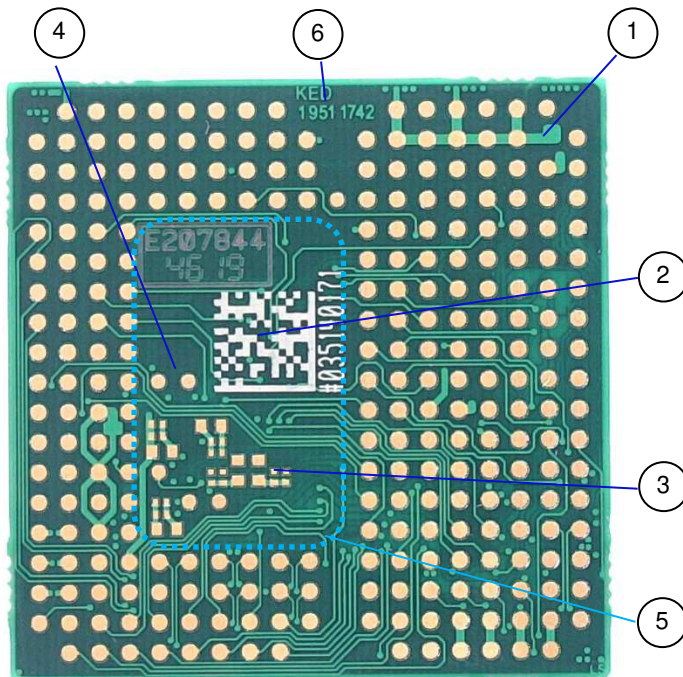

1. Pin 1 marking (missing pin)
2. Unique ID
3. Optional Components
4. Test points (factory use only)
5. Keep out area on base board
6. PCB revision

#### 4.4. Mechanical Drawings

Figure 5: Dimensions of SL iMX8MM

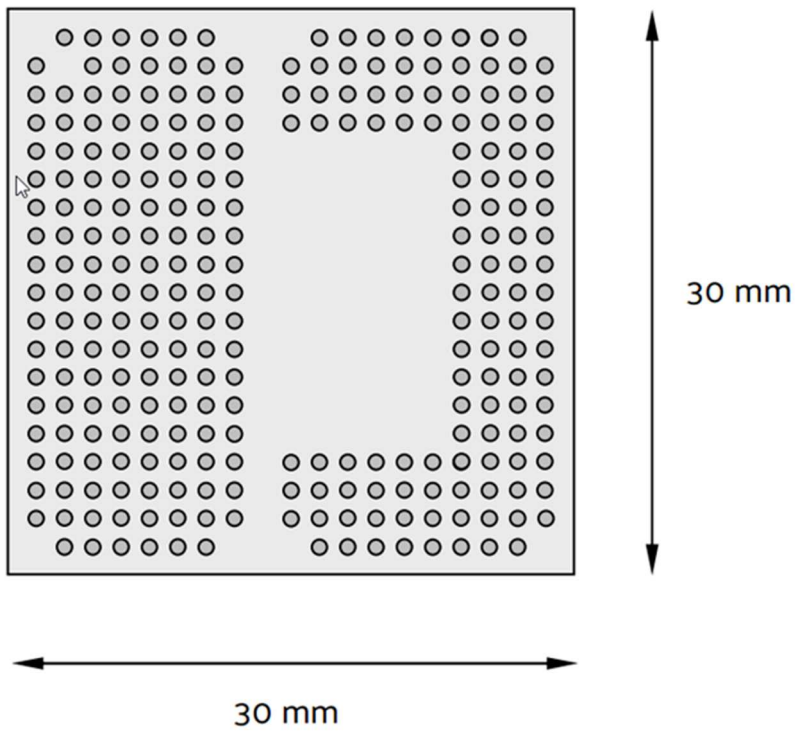

Figure 6: Footprint Grid

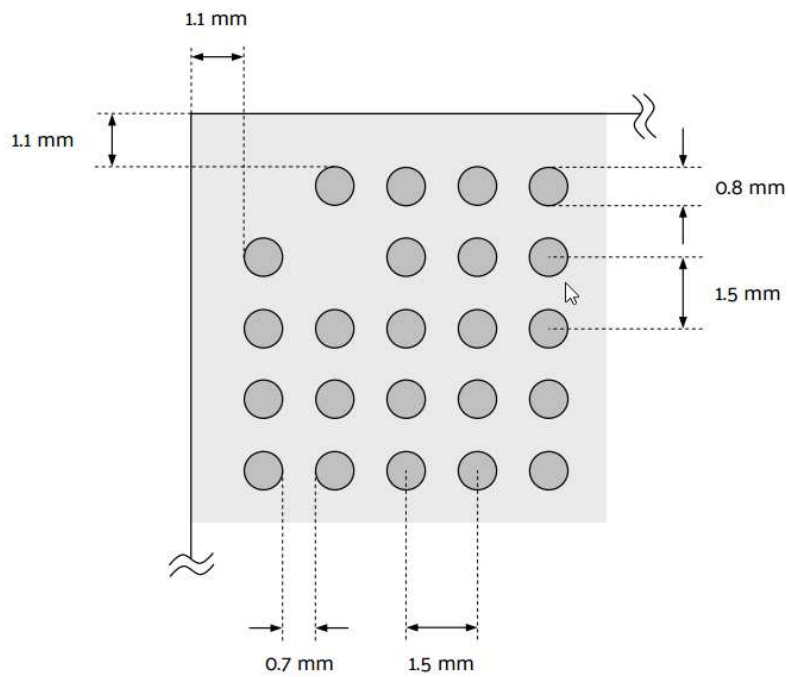
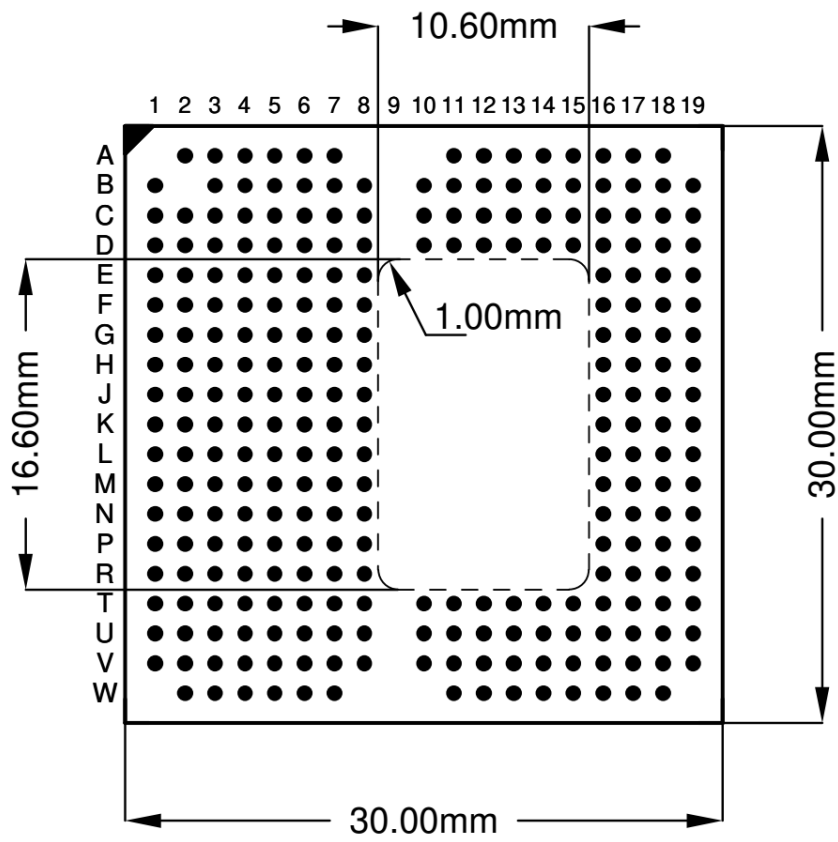
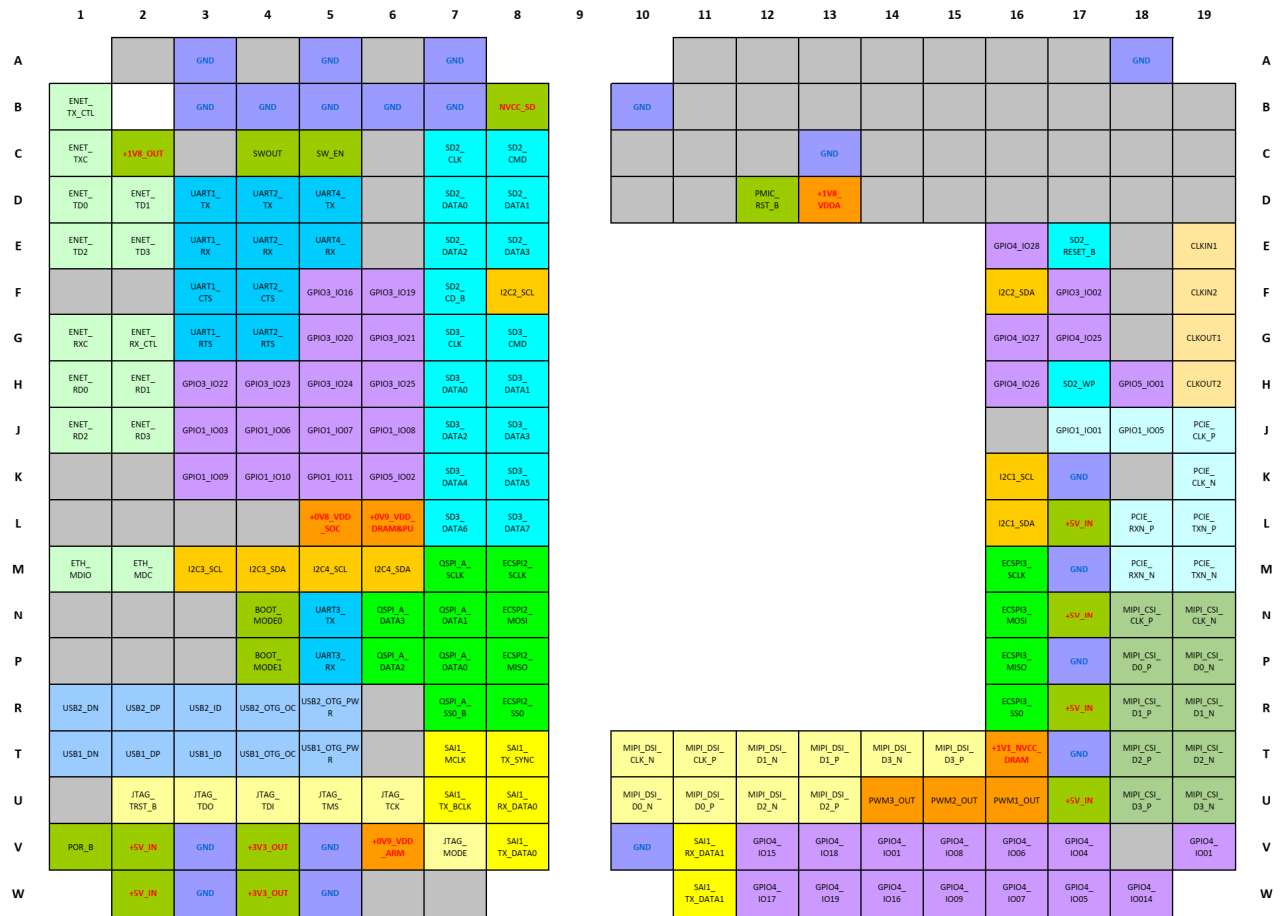

Figure 7: Keep out area on baseboard (top view)



### 4.5. Pinout diagram of SL iMX8MM

Figure 8: pin assignment (top view)



## 4.5.1. Pinout of SL iMX8MM

The pinout described here is the default pinout of the SoM. Please use “Pins Tool for i.MX Application Processors” to change the multiplexing. The tool can be downloaded from nxp homepage.

**NOTICE**

Changing the multiplexing creates the need of changing the device tree too.

Table 5: Pinout of SL iMX8MM

Pin	Signal	Module Direction	Module Termination	Voltage Level/Type	Controller	Controller Pin Name
A2	-	-	-	-	-	-
A3	GND	-	-	-	-	-
A4	-	-	-	-	-	-
A5	GND	-	-	-	-	-
A6	-	-	-	-	-	-
A7	GND	-	-	-	-	-
A11	-	-	-	-	-	-
A12	-	-	-	-	-	-
A13	-	-	-	-	-	-
A14	-	-	-	-	-	-
A15	-	-	-	-	-	-
A16	-	-	-	-	-	-
A17	-	-	-	-	-	-
A18	GND	-	-	-	-	-
B1	ENET1_RGMII_TX_CTL	Out	-	+1.8 V	i.MX8M Mini	ENET_TX_CTL
B3	GND	-	-	-	-	-
B4	GND	-	-	-	-	-
B5	GND	-	-	-	-	-
B6	GND	-	-	-	-	-
B7	GND	-	-	-	-	-
B8	NVCC_SD	-	-	-	-	-
B10	GND	-	-	-	-	-
B11	-	-	-	-	-	-
B12	-	-	-	-	-	-
B13	-	-	-	-	-	-
B14	-	-	-	-	-	-
B15	-	-	-	-	-	-
B16	-	-	-	-	-	-
B17	-	-	-	-	-	-
B18	-	-	-	-	-	-
B19	-	-	-	-	-	-
C1	ENET1_RGMII_TXC	Out	-	+1.8 V	i.MX8M Mini	ENET_TXC
C2	+1V8_OUT	PWR Out	-	-	PCA9450	BUCK5
C3	-	-	-	-	-	-
C4	SWOUT	PWR Out	-	-	PCA9450	SWOUT
C5	SW_EN	In	PU-10k	+3.3 V	PCA9450	SW_EN
C6	-	-	-	-	-	-

Pin	Signal	Module Direction	Module Termination	Voltage Level/Type	Controller	Controller Pin Name
C7	USDHC2_CLK	Out	-	+1.8 V/+3.3 V	i.MX8M Mini	SD2_CLK
C8	USDHC2_CMD	Bi-Dir	-	+1.8 V/+3.3 V	i.MX8M Mini	SD2_CMD
C10	-	-	-	-	-	-
C11	-	-	-	-	-	-
C12	-	-	-	-	-	-
C13	GND	-	-	-	-	-
C14	-	-	-	-	-	-
C15	-	-	-	-	-	-
C16	-	-	-	-	-	-
C17	-	-	-	-	-	-
C18	-	-	-	-	-	-
C19	-	-	-	-	-	-
D1	ENET1_RGMII_TD0	Out	-	+1.8 V	i.MX8M Mini	ENET_TD0
D2	ENET1_RGMII_TD1	Out	-	+1.8 V	i.MX8M Mini	ENET_TD1
D3	UART1_TX	Out	-	+3.3 V	i.MX8M Mini	SAI2_RXFS
D4	UART2_TX	Out	-	+3.3 V	i.MX8M Mini	SAI3_TXC
D5	UART4_TX	Out	-	+3.3 V	i.MX8M Mini	UART4_TXD
D6	-	-	-	-	-	-
D7	USDHC2_DATA0	Bi-Dir	-	+1.8 V/+3.3 V	i.MX8M Mini	SD2_DATA0
D8	USDHC2_DATA1	Bi-Dir	-	+1.8 V/+3.3 V	i.MX8M Mini	SD2_DATA1
D10	-	-	-	-	-	-
D11	-	-	-	-	-	-
D12	PMIC_RST_B	In	PU to +1V8_NVC_C_SNVS	+1V8	PCA9450	PMIC_RST_B
D13	+1V8_VDDA	PWR	-	-	PCA9450	LDO3
D14	-	-	-	-	-	-
D15	-	-	-	-	-	-
D16	-	-	-	-	-	-
D17	-	-	-	-	-	-
D18	-	-	-	-	-	-
D19	-	-	-	-	-	-
E1	ENET1_RGMII_TD2	Out	-	+1.8 V	i.MX8M Mini	ENET_TD2
E2	ENET1_RGMII_TD3	Out	-	+1.8 V	i.MX8M Mini	ENET_TD3
E3	UART1_RX	In	-	+3.3 V	i.MX8M Mini	SAI2_RXC
E4	UART2_RX	In	-	+3.3 V	i.MX8M Mini	SAI3_TXFS
E5	UART4_RX	In	-	+3.3 V	i.MX8M Mini	UART4_RXD
E6	-	-	-	-	-	-
E7	USDHC2_DATA2	Bi-Dir	-	+1.8 V/+3.3 V	i.MX8M Mini	SD2_DATA2
E8	USDHC2_DATA3	Bi-Dir	-	+1.8 V/+3.3 V	i.MX8M Mini	SD2_DATA3
E16	GPIO4_IO28	Bi-Dir	-	+3.3 V	i.MX8M Mini	SAI3_RXFS
E17	USDHC2_RESET_B	Out	-	+1.8 V/+3.3 V	i.MX8M Mini	SD2_RESET_B
E18	-	-	-	-	-	-
E19	CLKIN1	In	-	+1.8 v	i.MX8M Mini	CLKIN1
F1	-	-	-	-	-	-
F2	-	-	-	-	-	-
F3	UART1_CTS	Out	-	+3.3 v	i.MX8M Mini	SAI2_TXFS
F4	UART2_CTS	Out	-	+3.3 v	i.MX8M Mini	SAI3_RXC

Pin	Signal	Module Direction	Module Termination	Voltage Level/Type	Controller	Controller Pin Name
F5	GPIO3_IO16	Bi-Dir	-	+3.3 V	i.MX8M Mini	NAND_READY_B
F6	GPIO3_IO19	Bi-Dir	-	+3.3 V	i.MX8M Mini	SAI5_RXFS
F7	USDHC2_CD_B	In	-	+1.8 V/+3.3 V	i.MX8M Mini	SD2_CD_B
F8	I2C2_SCL	In	-	+3.3 V	i.MX8M Mini	I2C2_SCL
F16	I2C2_SDA	Bi-Dir	-	+3.3 V	i.MX8M Mini	I2C2_SDA
F17	GPIO3_IO02	Bi-Dir	-	+3.3 V	i.MX8M Mini	NAND_CE1_B
F18	-	-	-	-	-	-
F19	CLKIN2	In	-	+1.8 v	i.MX8M Mini	CLKIN2
G1	ENET1_RGMII_RXC	In	-	+1.8 v	i.MX8M Mini	ENET_RXC
G2	ENET1_RGMII_RX_CTL	In	-	+1.8 v	i.MX8M Mini	ENET_RX_CTL
G3	UART1_RTS	In	-	+3.3 v	i.MX8M Mini	SAI2_RXD0
G4	UART2_RTS	In	-	+3.3 v	i.MX8M Mini	SAI3_RXD
G5	GPIO3_IO20	Bi-Dir	-	+3.3 V	i.MX8M Mini	SAI5_RXC
G6	GPIO3_IO21	Bi-Dir	-	+3.3 V	i.MX8M Mini	SAI5_RXD0
G7	USDHC3_CLK	Out	-	+3.3 v	i.MX8M Mini	NAND_WE_B
G8	USDHC3_CMD	Bi-Dir	-	+3.3 V	i.MX8M Mini	NAND_WP_B
G16	GPIO4_IO27	Bi-Dir	-	+3.3 V	i.MX8M Mini	SAI2_MCLK
G17	GPIO4_IO25	Bi-Dir	-	+3.3 V	i.MX8M Mini	SAI2_TXC
G18	-	-	-	-	-	-
G19	CLKOUT1	Out	-	+1.8 v	i.MX8M Mini	CLKOUT1
H1	ENET1_RGMII_RD0	In	-	+1.8 v	i.MX8M Mini	ENET_RD0
H2	ENET1_RGMII_RD1	In	-	+1.8 v	i.MX8M Mini	ENET_RD1
H3	GPIO3_IO22	Bi-Dir	-	+3.3 V	i.MX8M Mini	SAI5_RXD1
H4	GPIO3_IO23	Bi-Dir	-	+3.3 V	i.MX8M Mini	SAI5_RXD2
H5	GPIO3_IO24	Bi-Dir	-	+3.3 V	i.MX8M Mini	SAI5_RXD3
H6	GPIO3_IO25	Bi-Dir	-	+3.3 V	i.MX8M Mini	SAI5_MCLK
H7	USDHC3_DATA0	Bi-Dir	-	+3.3 V	i.MX8M Mini	NAND_DATA04
H8	USDHC3_DATA1	Bi-Dir	-	+3.3 V	i.MX8M Mini	NAND_DATA05
H16	GPIO4_IO26	Bi-Dir	-	+3.3 V	i.MX8M Mini	SAI2_TXD0
H17	USDHC2_WP	In	-	+1.8 V/+3.3 V	i.MX8M Mini	SD2_WP
H18	GPIO5_IO01	Bi-Dir	-	+3.3 V	i.MX8M Mini	SAI3_TXD
H19	CLKOUT2	Out	-	+1.8 v	i.MX8M Mini	CLKOUT2
J1	ENET1_RGMII_RD2	In	-	+1.8 v	i.MX8M Mini	ENET_RD2
J2	ENET1_RGMII_RD3	In	-	+1.8 v	i.MX8M Mini	ENET_RD3
J3	GPIO1_IO03	Bi-Dir	-	+3.3 V	i.MX8M Mini	GPIO1_IO03
J4	GPIO1_IO06	Bi-Dir	-	+3.3 V	i.MX8M Mini	GPIO1_IO06
J5	GPIO1_IO07	Bi-Dir	-	+3.3 V	i.MX8M Mini	GPIO1_IO07
J6	GPIO1_IO08	Bi-Dir	-	+3.3 V	i.MX8M Mini	GPIO1_IO08
J7	USDHC3_DATA2	Bi-Dir	-	+3.3 V	i.MX8M Mini	NAND_DATA06
J8	USDHC3_DATA3	Bi-Dir	-	+3.3 V	i.MX8M Mini	NAND_DATA07
J16	-	-	-	-	-	-
J17	GPIO1_IO01	Bi-Dir	-	+3.3 V	i.MX8M Mini	GPIO1_IO01
J18	GPIO1_IO05	Bi-Dir	-	+3.3 V	i.MX8M Mini	GPIO1_IO05
J19	PCIE_CLK_P	Out	-	+1.8 v/LVDS PCIe	i.MX8M Mini	PCIE_CLK_P
K1	-	-	-	-	-	-
K2	-	-	-	-	-	-
K3	GPIO1_IO09	Bi-Dir	-	+3.3 V	i.MX8M Mini	GPIO1_IO09

Pin	Signal	Module Direction	Module Termination	Voltage Level/Type	Controller	Controller Pin Name
K4	GPIO1_IO10	Bi-Dir	-	+3.3 V	i.MX8M Mini	GPIO1_IO10
K5	GPIO1_IO11	Bi-Dir	-	+3.3 V	i.MX8M Mini	GPIO1_IO11
K6	GPIO5_IO02	Bi-Dir	-	+3.3 V	i.MX8M Mini	SAI3_MCLK
K7	USDHC3_DATA4	Bi-Dir	-	+3.3 V	i.MX8M Mini	NAND_RE_B
K8	USDHC3_DATA5	Bi-Dir	-	+3.3 V	i.MX8M Mini	NAND_CE2_B
K16	I2C1_SCL <sup>1)</sup>	Out	PU-4k75	+3.3 v	i.MX8M Mini	I2C1_SCL
K17	GND	-	-	-	-	-
K18	-	-	-	-	-	-
K19	PCIE_CLK_N	Out	-	+1.8 v/LVDS PCIe	i.MX8M Mini	PCIE_CLK_N
L1	-	-	-	-	-	-
L2	-	-	-	-	-	-
L3	-	-	-	-	-	-
L4	-	-	-	-	-	-
L5	+0V8_VDD_SOC	PWR	-	-	PCA9450	BUCK1
L6	+0V9_VDD_DRAM&PU	PWR	-	-	PCA9450	BUCK3
L7	USDHC3_DATA6	Bi-Dir	-	+3.3 V	i.MX8M Mini	NAND_CE3_B
L8	USDHC3_DATA7	Bi-Dir	-	+3.3 V	i.MX8M Mini	NAND_CLE
L16	I2C1_SDA <sup>1)</sup>	Bi-Dir	PU-4k75	+3.3 v	i.MX8M Mini	I2C1_SDA
L17	+5V_IN	PWR	-	-	-	-
L18	PCIE_RXN_P	In	-	+1.8 v/LVDS PCIe	i.MX8M Mini	PCIE_RXN_P
L19	PCIE_TXN_P	Out	Seriell-100n	+1.8 v/LVDS PCIe	i.MX8M Mini	PCIE_TXN_P
M1	ENET1_MDIO	Bi-Dir	-	+1.8 v	i.MX8M Mini	ENET_MDIO
M2	ENET1_MDC	Out	-	+1.8 v	i.MX8M Mini	ENET_MDC
M3	I2C3_SCL	Out	PU-4k75	+3.3 v	i.MX8M Mini	I2C3_SCL
M4	I2C3_SDA	Bi-Dir	PU-4k75	+3.3 v	i.MX8M Mini	I2C3_SDA
M5	I2C4_SCL	Out	PU-4k75	+3.3 v	i.MX8M Mini	I2C4_SCL
M6	I2C4_SDA	Bi-Dir	PU-4k75	+3.3 v	i.MX8M Mini	I2C4_SDA
M7	QSPIA_SCLK	Out	-	+3.3 v	i.MX8M Mini	NAND_ALE
M8	ECSPI2_SCLK	Out	-	+3.3 v	i.MX8M Mini	ECSPI2_SCLK
M16	ECSPI3_SCLK	Out	-	+3.3 v	i.MX8M Mini	UART1_RXD
M17	GND	-	-	-	-	-
M18	PCIE_RXN_N	In	-	+1.8 v/LVDS PCIe	i.MX8M Mini	PCIE_RXN_N
M19	PCIE_TXN_N	Out	Seriell-100n	+1.8 v/LVDS PCIe	i.MX8M Mini	PCIE_TXN_N
N1	-	-	-	-	-	-
N2	-	-	-	-	-	-
N3	-	-	-	-	-	-
N4	BOOT_MODE0	In	PD	+3.3 v	i.MX8M Mini	BOOT_MODE0
N5	UART3_TX	Out	-	+3.3 v	i.MX8M Mini	UART3_TXD
N6	QSPLA_DATA3	Bi-Dir	-	+3.3 v	i.MX8M Mini	NAND_DATA03
N7	QSPLA_DATA1	Bi-Dir	-	+3.3 v	i.MX8M Mini	NAND_DATA01
N8	ECSPI2_MOSI	Out	-	+3.3 v	i.MX8M Mini	ECSPI2_MOSI
N16	ECSPI3_MOSI	Out	-	+3.3 v	i.MX8M Mini	UART1_TXD
N17	+5V_IN	PWR	-	-	-	-
N18	MIPI_CSI_CLK_P	In	-	+1.8 v/LVDS D-PHY	i.MX8M Mini	MIPI_CSI_CLK_P
N19	MIPI_CSI_CLK_N	In	-	+1.8 v/LVDS D-PHY	i.MX8M Mini	MIPI_CSI_CLK_N
P1	-	-	-	-	-	-

Pin	Signal	Module Direction	Module Termination	Voltage Level/Type	Controller	Controller Pin Name
P2	-	-	-	-	-	-
P3	-	-	-	-	-	-
P4	BOOT_MODE1	In	PD	+3.3 v	i.MX8M Mini	BOOT_MODE1
P5	UART3_RX	In	-	+3.3 v	i.MX8M Mini	UART3_RXD
P6	QSPI_A_DATA2	Bi-Dir	-	+3.3 v	i.MX8M Mini	NAND_DATA02
P7	QSPI_A_DATA0	Bi-Dir	-	+3.3 v	i.MX8M Mini	NAND_DATA00
P8	ECSPI2_MISO	In	-	+3.3 v	i.MX8M Mini	ECSPI2_MISO
P16	ECSPI3_MISO	In	-	+3.3 v	i.MX8M Mini	UART2_RXD
P17	GND	-	-	-	-	-
P18	MIPI_CSI_D0_P	In	-	+1.8 v/LVDS D-PHY	i.MX8M Mini	MIPI_CSI_D0_P
P19	MIPI_CSI_D0_N	In	-	+1.8 v/LVDS D-PHY	i.MX8M Mini	MIPI_CSI_D0_N
R1	USB2_DN	Bi-Dir	-	USB	i.MX8M Mini	USB2_DN
R2	USB2_DP	Bi-Dir	-	USB	i.MX8M Mini	USB2_DP
R3	USB2_ID	In	-	+1.8 v	i.MX8M Mini	USB2_ID
R4	USB2_OTG_OC	In	-	+3.3 v	i.MX8M Mini	GPIO1_IO15
R5	USB2_OTG_PWR	Out	-	+3.3 v	i.MX8M Mini	GPIO1_IO14
R6	-	-	-	-	-	-
R7	QSPI_A_SS0_B	Out	PU-10k	+3.3 v	i.MX8M Mini	NAND_CE0_B
R8	ECSPI2_SS0	Out	-	+3.3 v	i.MX8M Mini	ECSPI2_SS0
R16	ECSPI3_SS0	Out	-	+3.3 v	i.MX8M Mini	UART2_TXD
R17	+5V_IN	PWR	-	-	-	-
R18	MIPI_CSI_D1_P	In	-	+1.8 v/LVDS D-PHY	i.MX8M Mini	MIPI_CSI_D1_P
R19	MIPI_CSI_D1_N	In	-	+1.8 v/LVDS D-PHY	i.MX8M Mini	MIPI_CSI_D1_N
T1	USB1_DN	Bi-Dir	-	USB	i.MX8M Mini	USB1_DN
T2	USB1_DP	Bi-Dir	-	USB	i.MX8M Mini	USB1_DP
T3	USB1_ID	In	-	+1.8 v	i.MX8M Mini	USB1_ID
T4	USB1_OTG_OC	In	-	+3.3 v	i.MX8M Mini	GPIO1_IO13
T5	USB1_OTG_PWR	Out	-	+3.3 v	i.MX8M Mini	GPIO1_IO12
T6	-	-	-	-	-	-
T7	SAI1_MCLK	Out	-	+3.3 v	i.MX8M Mini	SAI1_MCLK
T8	SAI1_TX_SYNC	Out	-	+3.3 v	i.MX8M Mini	SAI1_TXFS
T10	MIPI_DSI_CLK_N	Out	-	+1.8 v/LVDS D-PHY	i.MX8M Mini	MIPI_DSI_CLK_N
T11	MIPI_DSI_CLK_P	Out	-	+1.8 v/LVDS D-PHY	i.MX8M Mini	MIPI_DSI_CLK_P
T12	MIPI_DSI_D1_N	Out	-	+1.8 v/LVDS D-PHY	i.MX8M Mini	MIPI_DSI_D1_N
T13	MIPI_DSI_D1_P	Out	-	+1.8 v/LVDS D-PHY	i.MX8M Mini	MIPI_DSI_D1_P
T14	MIPI_DSI_D3_N	Out	-	+1.8 v/LVDS D-PHY	i.MX8M Mini	MIPI_DSI_D3_N
T15	MIPI_DSI_D3_P	Out	-	+1.8 v/LVDS D-PHY	i.MX8M Mini	MIPI_DSI_D3_P
T16	+1V1_NVCC_DRAM	PWR	-	-	PCA9450	BUCK6
T17	GND	-	-	-	-	-
T18	MIPI_CSI_D2_P	In	-	+1.8 v/LVDS D-PHY	i.MX8M Mini	MIPI_CSI_D2_P

Pin	Signal	Module Direction	Module Termination	Voltage Level/Type	Controller	Controller Pin Name
T19	MIPI_CSI_D2_N	In	-	+1.8 v/LVDS D-PHY	i.MX8M Mini	MIPI_CSI_D2_N
U1	-	-	-	-	-	-
U2	JTAG_TRST_B	In	-	+3.3 v	i.MX8M Mini	JTAG_TRST_B
U3	JTAG_TDO	Out	-	+3.3 v	i.MX8M Mini	JTAG_TDO
U4	JTAG_TDI	In	-	+3.3 v	i.MX8M Mini	JTAG_TDI
U5	JTAG_TMS	In	-	+3.3 v	i.MX8M Mini	JTAG_TMS
U6	JTAG_TCK	In	-	+3.3 v	i.MX8M Mini	JTAG_TCK
U7	SAI1_TX_BCLK	Out	-	+3.3 v	i.MX8M Mini	SAI1_TXC
U8	SAI1_RX_DATA0	In	-	+3.3 v	i.MX8M Mini	SAI1_RXD0
U10	MIPI_DSI_D0_N	Out	-	+1.8 v/LVDS D-PHY	i.MX8M Mini	MIPI_DSI_D0_N
U11	MIPI_DSI_D0_P	Out	-	+1.8 v/LVDS D-PHY	i.MX8M Mini	MIPI_DSI_D0_P
U12	MIPI_DSI_D2_N	Out	-	+1.8 v/LVDS D-PHY	i.MX8M Mini	MIPI_DSI_D2_N
U13	MIPI_DSI_D2_P	Out	-	+1.8 v/LVDS D-PHY	i.MX8M Mini	MIPI_DSI_D2_P
U14	PWM3_OUT	Out	-	+3.3 v	i.MX8M Mini	SPDIF_TX
U15	PWM2_OUT	Out	-	+3.3 v	i.MX8M Mini	SPDIF_RX
U16	PWM1_OUT	Out	-	+3.3 v	i.MX8M Mini	SPDIF_EXT_CLK
U17	+5V_IN	PWR	-	-	-	-
U18	MIPI_CSI_D3_P	In	-	+1.8 v/LVDS D-PHY	i.MX8M Mini	MIPI_CSI_D3_P
U19	MIPI_CSI_D3_N	In	-	+1.8 v/LVDS D-PHY	i.MX8M Mini	MIPI_CSI_D3_N
V1	POR_B	In	PU-100k	+1.8 v	i.MX8M Mini	POR_B
V2	+5V_IN	PWR	-	-	-	-
V3	GND	-	-	-	-	-
V4	+3V3_OUT	PWR Out	-	-	PCA9450	BUCK4
V5	GND	-	-	-	-	-
V6	+0V9_VDD_ARM	PWR	-	-	PCA9450	BUCK2
V7	JTAG_MODE	In	PD-4k75	+3.3 v	i.MX8M Mini	JTAG_MOD
V8	SAI1_TX_DATA0	Out	-	+3.3 v	i.MX8M Mini	SAI1_TXD0
V10	GND	-	-	-	-	-
V11	SAI1_RX_DATA1	In	-	+3.3 v	i.MX8M Mini	SAI1_RXD1
V12	GPIO4_IO15	Bi-Dir	-	+3.3 v	i.MX8M Mini	SAI1_TXD3
V13	GPIO4_IO18	Bi-Dir	-	+3.3 v	i.MX8M Mini	SAI1_TXD6
V14	GPIO4_IO00	Bi-Dir	-	+3.3 v	i.MX8M Mini	SAI1_RXFS
V15	GPIO4_IO08	Bi-Dir	-	+3.3 v	i.MX8M Mini	SAI1_RXD6
V16	GPIO4_IO06	Bi-Dir	-	+3.3 v	i.MX8M Mini	SAI1_RXD4
V17	GPIO4_IO04	Bi-Dir	-	+3.3 v	i.MX8M Mini	SAI1_RXD2
V18	-	-	-	-	-	-
V19	GPIO4_IO01	Bi-Dir	-	+3.3 v	i.MX8M Mini	SAI1_RXC
W2	+5V_IN	PWR	-	-	-	-
W3	GND	-	-	-	-	-
W4	+3V3_OUT	PWR Out	-	-	PCA9450	BUCK4
W5	GND	-	-	-	-	-
W6	-	-	-	-	-	-
W7	-	-	-	-	-	-

Pin	Signal	Module Direction	Module Termination	Voltage Level/Type	Controller	Controller Pin Name
W11	SAI1_TX_DATA1	Out	-	+3.3 v	i.MX8M Mini	SAI1_TXD1
W12	GPIO4_IO17	Bi-Dir	-	+3.3 v	i.MX8M Mini	SAI1_TXD5
W13	GPIO4_IO19	Bi-Dir	-	+3.3 v	i.MX8M Mini	SAI1_TXD7
W14	GPIO4_IO16	Bi-Dir	-	+3.3 v	i.MX8M Mini	SAI1_TXD4
W15	GPIO4_IO09	Bi-Dir	-	+3.3 v	i.MX8M Mini	SAI1_RXD7
W16	GPIO4_IO07	Bi-Dir	-	+3.3 v	i.MX8M Mini	SAI1_RXD5
W17	GPIO4_IO05	Bi-Dir	-	+3.3 v	i.MX8M Mini	SAI1_RXD3
W18	GPIO4_IO14	Bi-Dir	-	+3.3 v	i.MX8M Mini	SAI1_TXD2

- 1) I2C1 is also used for internal PMIC
- 2) NVCC\_SD on B8 is not available on older PCBs (1 950 1742 to 1 952 1742)

## 5/ Installation

### 5.1. Power Control

#### 5.1.1. Power Supply

The SoM can be powered from a single 5V power source at +5V\_IN pin.

The power pins +1V8\_OUT (C2) and +3V3\_OUT (V4/W4) can be used to power peripherals on the mainboard with a maximum load of 1 A each.

#### NOTICE

There is no current limiting device for the voltage outputs. Drawing too much current may damage the device and/or lead to malfunction.

Figure 9: power supply scheme

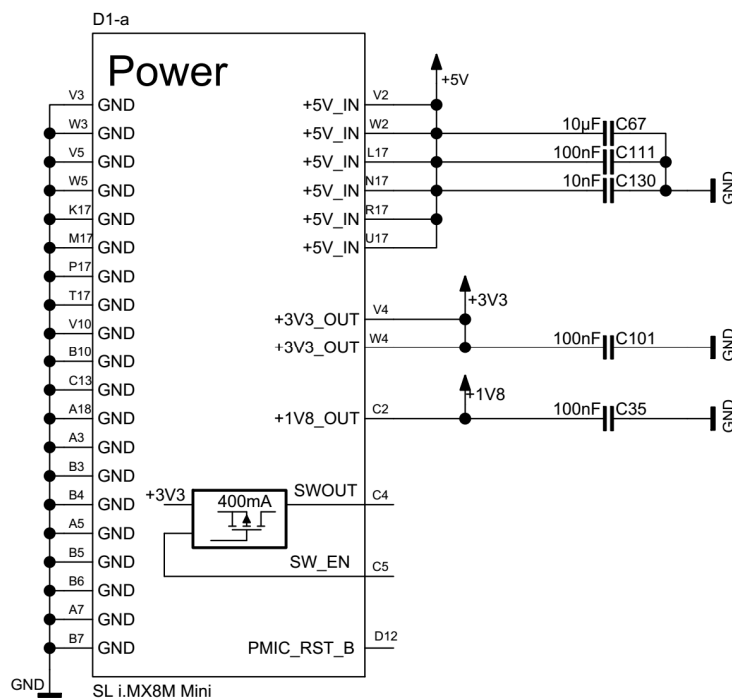

The following parameters should be delivered from the carrier board:

- ▶ Voltage Ripple maximum 100 mV peak to peak 0-20 MHz to 20 ms rise time from input voltage <10% to nominal VCC

#### 5.1.2. Supply voltage

Table 6: Supply voltage

Voltage	nominal	min	max
+5V_IN	5	4.5	5.5

### 5.1.3. Supply current

The supply current is measured on the SoM using the following commands:

Stresstest on all 4 CPUs:

```
stress-ng --matrix 0 -t 0
```

Stresstest on all 4 CPUs and RAM:

```
stress-ng --matrix 0 -t 0 --vm 4 --vm-bytes 50%
```

Table 7: Supply current

Use case	mean	max peak
Linux running	170 mA	TBD
stresstest on 4xCPU	355 mA	TBD
stresstest on 4xCPU and RAM	500 mA	TBD

### 5.2. Reset pin

A low level at POR\_B triggers a reset. The module will stay in reset as long as POR\_B is grounded. Connect an open drain output or ground switch to POR\_B. If unused, this pin can be left floating. No external components are required.

### 5.3. Boot Mode

The device has four boot modes (one is reserved for NXP use).

Table 8: Boot mode pin settings

BOOT_MODE[1:0]	Boot Type
00	Boot From Fuses
01	Serial Downloader
10	Internal Boot
11	Reserved

BOOT\_MODE[1:0] pins have internal pull-downs. By default, these pins can be left floating to stay in “Boot from Fuses” mode. In this mode the SoM boots as programmed by Kontron.

#### 5.3.1. SD/MMC manufacture mode

If no valid boot image is found on the programmed boot devices the SoM switches to SD/MMC manufacture mode before the serial download mode. In the manufacture mode, one-bit bus width is used on uSDHC2 interface to load a boot image from SD card.

#### 5.3.2. Serial Downloader

The Serial Downloader provides a means to download a program image to the chip over the USB OTG1 serial connection.



It is recommended to have the boot pins and the OTG1 pins available on the baseboard to recover the SoM in case of a broken image. In addition, also the SD1 pins and the pins for the Linux console should be accessible.

#### 5.4. SD card

The i.MX8M Mini has three uSDHC interfaces that are compliant to SD/SDIO 3.0 with 200 MHz SDR signalling to support up to 100 MB/sec.

Figure 10: SD-Card connection example

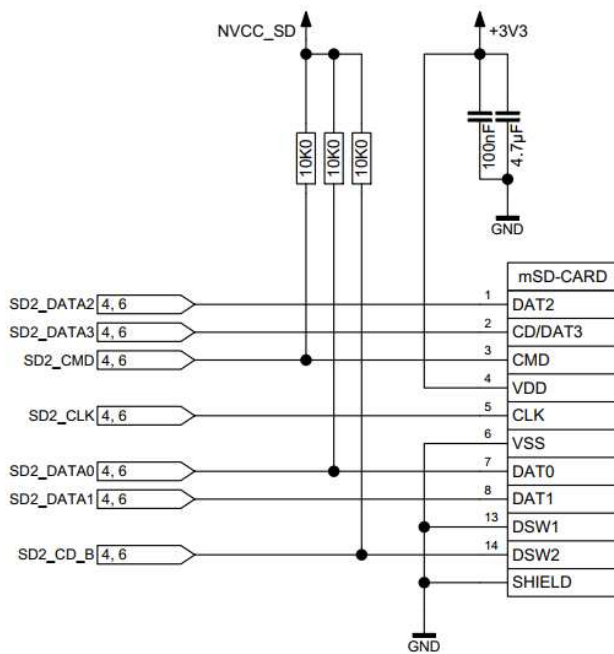

If UHS-I mode is required uSDHC2 should be used as this interface is powered from a dedicated LDO and the supply can be switched from +3.3 V to +1.8 V. This voltage NVCC\_SD is accessible on pin B8 to connect external pull-ups.

## 6/ Thermal considerations



---

TO BE DEFINED  
CONTENT FOLLOWS WITH NEXT DOCUMENT VERSION

---

## 7/ Reflow profile

Table 9: Reflow profile

Profile Feature	Pb-Free Assembly
Average Ramp-Up Rate ( $T_{SMAX}$ to $T_P$ )	3°C/second max.
<b>Preheat</b>	
Temperature Min ( $T_{SMIN}$ )	150 °C
Temperature Max ( $T_{SMAX}$ )	200 °C
Time ( $t_s$ ) from ( $T_{SMIN}$ to $T_{SMAX}$ )	60-120 seconds
Liquidous temperature ( $T_L$ )	217 °C
Time ( $t_L$ ) maintained above $T_L$	60-80 seconds
Peak/Classification Temperature ( $T_P$ )	250 °C
Time within 5 °C of actual peak temperature ( $t_P$ )	20 seconds
Ramp-down rate	6°C/second max
Time 25 °C to peak temperature	8 minutes max

Figure 11: Reflow Classification Profile

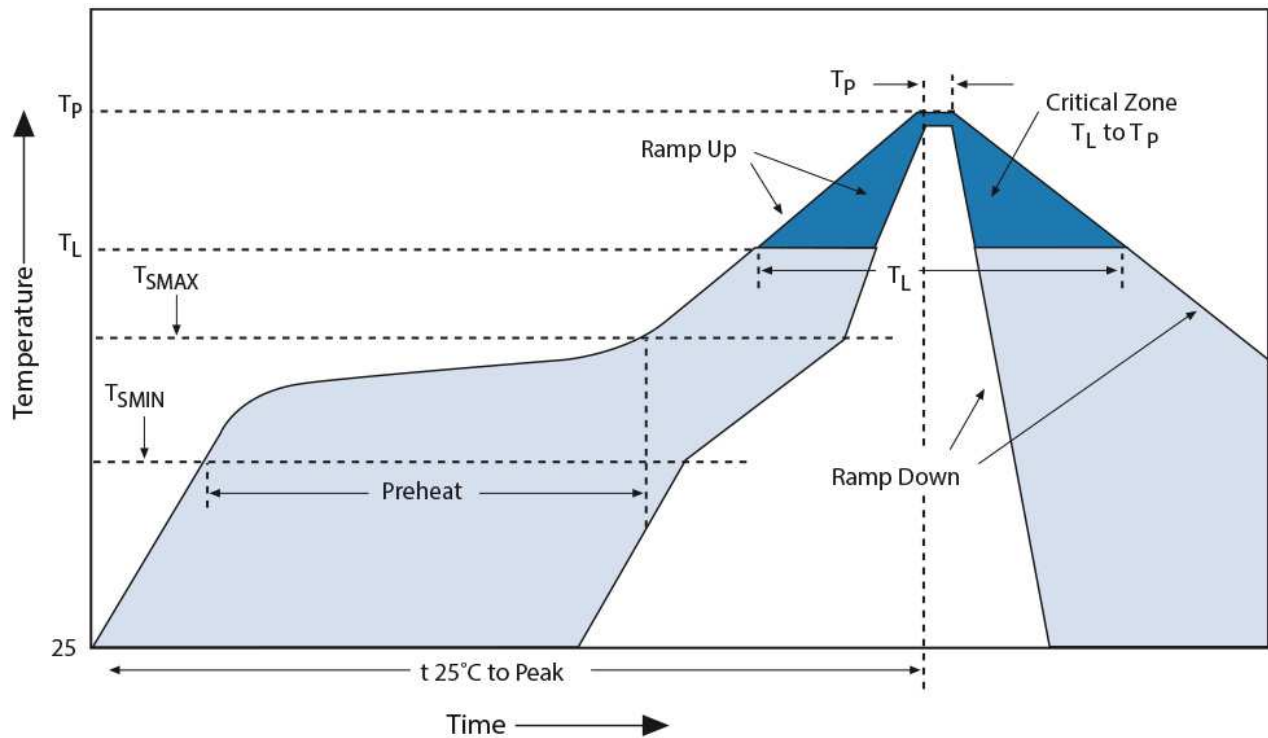

To minimize the stress for the components, it is strongly recommended to solder the SoM during the last reflow cycle of the carrier board manufacturing process.

## 8/ Technical Support

### 8.1. First Steps - Startup-Information Baseboard

For the first startup of your Board, which includes the SL iMX8MM SoM, you will find more information about the Software / BSP and additional hardware information at the online documentation.

Please follow the link <https://docs.kontron-electronics.de/yocto-ktn/build-ktn-imx/>

The online documentation is primarily intended for our Eval-Kit / Evalboard, but will help you also to put your board into operation. Additionally, you will find information how to get access to the Yocto based GitLab software repository and how to make your own software images.

### 8.2. Extended Support

For detailed technical support please contact:

- ▶ E-Mail: [support@kontron-electronics.de](mailto:support@kontron-electronics.de)

### 8.3. Disclaimer & License Information

The software contained in the device (BSP) contains parts which were licensed as free respectively open source software under the GNU General Public License, version 2 and/or 3, respectively the GNU Lesser General Public License, versions 2.1 and/or 3.0.

You can obtain a copy of the source code of the BSP by following the instructions in the manual at <https://docs.kontron-electronics.de/build-system> or contact:

Kontron Electronics GmbH  
Kantstr. 10  
72663 Großbettingen  
Germany  
Web: [www.kontron-electronics.de](http://www.kontron-electronics.de)  
E-Mail: [support@kontron-electronics.de](mailto:support@kontron-electronics.de)

## About Kontron Electronics

Kontron Electronics is your complete supplier of electronics and automation solutions. We offer

- ▶ own control products for the automation of machines and devices,
- ▶ Development and production for individual, complex electronic modules
- ▶ Production services for your existing electronic assemblies
- ▶ Assembly services for complete systems

With our existing control, visualisation and automation systems, we can put together turnkey complete solutions for your machines and equipment in the shortest possible time.

For your individual requirements we have a large group of engineers and technicians available, who develop your tailor-made solution with a lot of experience and imagination.

Kontron Electronics is a full-service provider for the development and production of complex electronic modules, components and systems for industrial and medical applications.



Kontron Electronics  
GmbH

Kantstraße 10  
72663 Großbottlingen  
Germany  
Tel.: +49 7022 4057-0  
Fax: +49 7022 4057-22  
[info@kontron-electronics.de](mailto:info@kontron-electronics.de)