



Part list:

- J1: 40-pole connector Don Connex A32-40-C-G-B-1
- J2: 30-pole connector FAE FI-E30S mate + 25 pieces Crimp terminals for J2
- Cable: 1500mm 2x20 twisted pair flat cable Amphenol Spectra Strip 125-3007-040.
- HST: 3 pieces of Heat Shrinkable Tube.
- Switch: PCB containing Switch circuit for V_{DD}

Display (30-pole conn.)		40-pole connector		Remarks
Pin no.	Function	Pin	Function	
1	NC	-	-	No Connection
2	NC	-	-	No Connection
3	NC	-	-	No Connection
4	GND	6, 8, 16, 27, 28, 39, 40	GND	Connect to Switch circuit GND
5	Rx0-	17	A0-	Pair no 1
6	Rx0+	18	A0+	Pair no 1
7	GND	6, 8, 16, 27, 28, 39, 40	GND	Connect to Switch circuit GND
8	Rx1-	19	A1-	Pair no 2
9	Rx1+	20	A1+	Pair no 2
10	GND	6, 8, 16, 27, 28, 39, 40	GND	Connect to Switch circuit GND
11	Rx2-	21	A2-	Pair no 3
12	Rx2+	22	A2+	Pair no 3
13	GND	6, 8, 16, 27, 28, 39, 40	GND	Connect to Switch circuit GND
14	RxCLK-	23	CLK1-	Pair no 4
15	RxCLK+	24	CLK1+	Pair no 4
16	GND	6, 8, 16, 27, 28, 39, 40	GND	Connect to Switch circuit GND
17	Rx3-	25	A3-	Pair no 5
18	Rx3+	26	A3+	Pair no 5
19	GND	6, 8, 16, 27, 28, 39, 40	GND	Connect to Switch circuit GND
20	NC	-	-	No Connection
21	LVDS Option	6, 8, 16, 27, 28, 39, 40	GND	3.3V/GND => OpenLDI/SPWG
22	NC	-	-	No Connection
23	GND	6, 8, 16, 27, 28, 39, 40	GND	Connect to Switch circuit GND
24	GND	6, 8, 16, 27, 28, 39, 40	GND	Connect to Switch circuit GND
25	GND	6, 8, 16, 27, 28, 39, 40	GND	Connect to Switch circuit GND
26	V_{DD}	-	-	Connect to Switch circuit V_{DD}
27	V_{DD}	-	-	Connect to Switch circuit V_{DD}
28	V_{DD}	-	-	Connect to Switch circuit V_{DD}
29	V_{DD}	-	-	Connect to Switch circuit V_{DD}
30	V_{DD}	-	-	Connect to Switch circuit V_{DD}

Note: J1 Unused wire 7 in a HST (Heat Shrinkable Tube). Unused wires 11 and 12 in HST.

Display (30-pole conn.)		40-pole connector		Remarks
Pin no.	Function	Pin	Function	
1	AWG24 16,5 V	-	-	
2	AWG24 16,5 V	-	-	
3	AWG24 16,5 V	-	-	
4	AWG24 16,5 V	-	-	
5	AWG24 16,5 V	-	-	
6	AWG24 GND	-	-	
7	AWG24 GND	-	-	
8	AWG24 GND	-	-	
9	AWG24 GND	-	-	
10	AWG24 GND	-	-	
11	Analog Dimmer	-	-	No Connection
12	Backlight On	15	BKLTEN#	(2.4-5V)/(0.8 -0V) => On/Off
13	PWM Dimmer	13	BKLTCTL	PWM dimming
14	GND	-	-	Connect to AWG24 GND

Note: If Inverter is controlled by 886LCD-M via LVDS connector then PC Power Supply ground and Inverter Power Supply ground shall be connected.

Switch circuit:

Connect POWER5V to +5V power supply
 Connect POWER12V to LVDS cable wire 1 - 5
 Ground GND to GND of +5V power supply and to LVDS cable wire 6, 8, 16, 27, 28, 39 and 40
 Connect CONTROL SIGNAL to LVDS cable wire 14 "VDD ENABLE"
 Connect V_{DD} to display connector pin 26 - 30

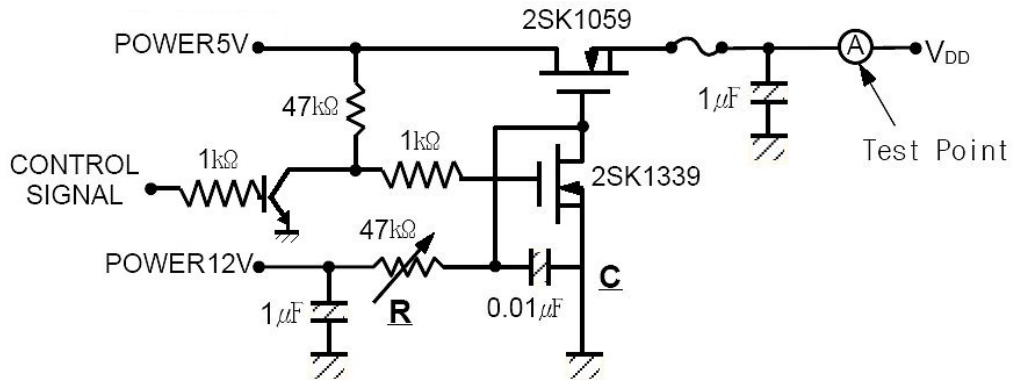

The rising time of supplied voltage is controlled to 470us by R and C value.

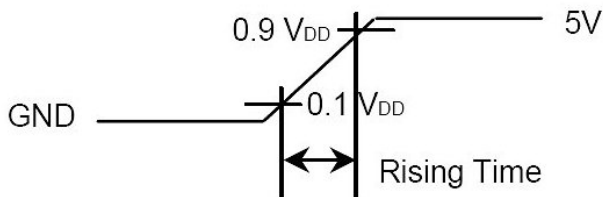

Note: The 2SK1059 can be replaced with 2 pieces of MTP3055V working in parallel and the 2SK1339 can be replaced with a MTP3055V.

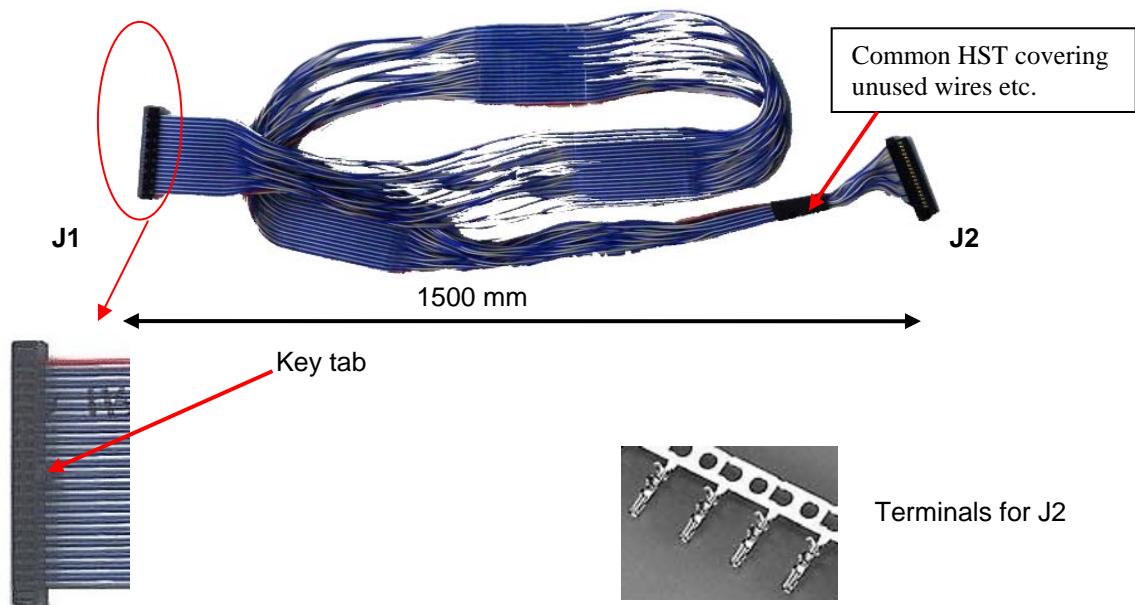

Note: The above picture does not show the exact cable kit: Switch circuit is not shown and the cable is not really having the specified length.