

» CP6012 «

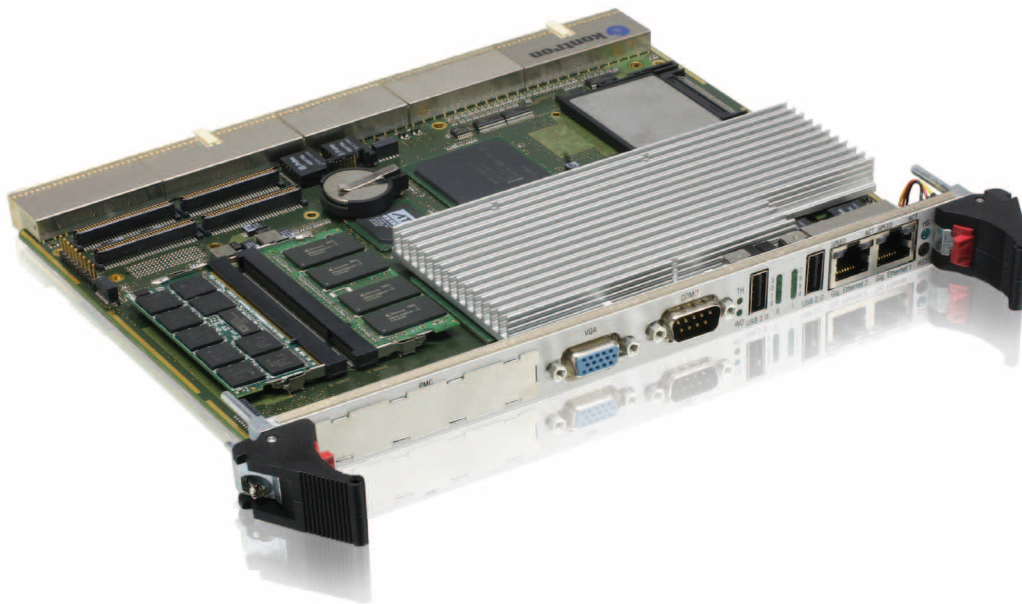

6U Intel® Core™ Duo Processor PICMG 2.16 Blade

» Highest Performance / Watt

Intel® T2500 Duo processor 2.0 GHz

» Highest Memory Density

Up to 4 GByte dual-channel, DDR2, 400 MHz memory

» Highest Versatility

Comprehensive I/O capabilities: GigEthernet, PMC/XMC, USB, VGA, SATA, CompactFlash ...

The Power of Intel® Core™ Duo

Nearly double your processing power...

Explore the power and the potential of two cores in one processor with Kontron's CP6012 based on the Intel® Core™ Duo processor.

The CP6012, a 6U CompactPCI CPU board with Intel® Core™ Duo processor meets the highest performance demands. Combined with the E7520 and 6300ESB chipset, it handles server-like data throughput and provides next generation bandwidth capabilities.

» Greater Performance / Watt

Compared to previous processor designs the dual-core technology allows approximately twice the performance at similar power consumption.

The PICMG 2.16-compliant Kontron CP6012 offers up to 4 GB dual-channel 400 MHz DDR2 registered ECC SDRAM (via two 200-pin SODIMM sockets), providing up to 6.4 GB/sec data throughput. The CP6012 is designed for bandwidthintensive applications and thanks to hotswap support and IPMI (PICMG 2.9 - compliant Intelligent Platform Management Interface) the CPU board meets the highest demands for the management of high-availability applications. Many of these are data and tele-communications applications, but also include highly sensitive, securityrelated solutions as well as image processing systems in medical technology and other vertical industries.

» Unique Versatility

The highly integrated CP6012 features a XMC site according to XMC.3 supporting x8 PCI Express (alternatively a 64/66 PCI PMC site), an onboard 2.5-inch SATA hard disk and CompactFlash - all usable at the same time in a single slot.

The Intel 6300ESB I/O Controller Hub provides advanced I/O technology including USB 2.0 and Serial ATA150. Four Gigabit Ethernet ports (2x ports at the front and 2x for full PICMG 2.16 support) provide comprehensive connectivity capabilities, enabling innovative applications today by offering enough headroom for the emerging next generation requirements. Highly versatile, the CP6012 can be used in a system or peripheral slot. A rich set of LEDs at the front panel for debug and diagnose, as well as full rear I/O connectivity completes the CP6012.

» Longterm Availability

Delivering a stable product based on Intel's embedded product line, the CP6012 ensures long term availability. This eliminates the risk of unplanned design changes and unexpected expensive application modification.

While minimizing deployment risks, the CP6012 provides a broad range of software support to ease the process of product integration and maximize the competitive advantage of meeting the time-to-market window.

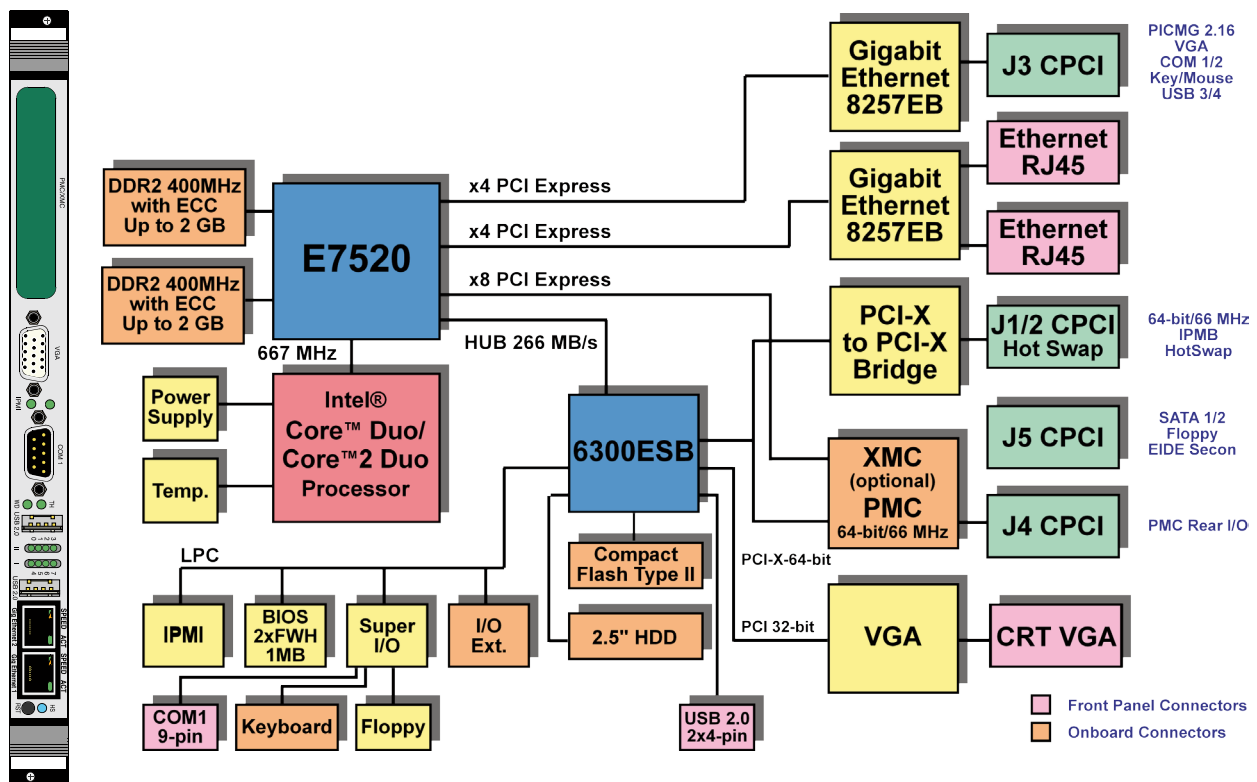

Technical Information

Processor Intel® Core™ Duo processor in micro-FCBGA package (65nm manufacturing process)
 » T2500: 2.00 GHz, 667 MHz FSB, 2 MB L2, FCBGA
 » L2400: LV 1.66 GHz, 667 MHz FSB, 2 MB L2, FCBGA
 All board versions are provided with a passive heatsink within 4HP height. Forced air cooling at a specific flow rate is required.

Memory Controller Intel® E7520 supporting various RASUM features

Memory
 » Up to 4 GB DDR2 400 MHz dual channel registered SDRAM w/ ECC via two 200-pin SODIMM sockets for max. 6.4 GB/sec data throughput
 » 2 redundant 1 MB Firmware Hubs (FWH) for BIOS
 » 8 kB for storing CMOS data when operating without battery

I/O
 » Four 10/100/1000 MB/s Gigabit Ethernet ports based on two Intel® 82571EB dual Gigabit Ethernet PCI Express bus controllers (two copper ports are routed to the front and two copper ports are routed to PICMG 2.16 rear pins)
 » Four USB 2.0 interfaces with up to 480 Mbit/sec, two front, two rear
 » VGA Video Controller ATI ES1000 2D-engine, PCI 32-bit / 33 MHz, external memory 64MB
 » Two 16C550 compatible UARTs (COM1/2)
 » Keyboard on rear and onboard connector
 » Mouse interface on rear
 » Floppy disk controller on rear

Front Panel Functions

COM1	9-pin D-Sub (RS232)
VGA	15-pin D-Sub SVGA connector
Ethernet	2x RJ-45
USB	2x 4-pin connectors
PMC/XMC	opening for PMC/XMC front panel
LEDs	2x LAN activity (yellow) and speed (green), one blue control LED for hot swap, 2x for IPMI, 1x watchdog, 1x thermal control, 8-LED-field for BIOS POST code or general purpose
Reset	reset button, guarded
Micro switch	for hot swap

Onboard Interfaces
 » One SATA connection for an onboard 2.5" SATA HDD
 » CompactFlash type II socket
 » 22-pin connector with all LPC signals
 » PS/2 keyboard connector
 » 2x 200-pin SODIMM connectors
 » 4x 64-pin PMC interface
 » 1x 114-pin XMC connector

I/O Table Summary

	Front I/O	Rear I/O	Onboard Connector	Total
Video	1	1	-	1
USB	2	2	-	4
Serial	1	2	-	2
PS/2 Mouse	-	1	-	1
PS/2 Keyboard	-	1	1	1
Ethernet	2	2	-	4
ATA100	-	1	-	1
SATA150	-	2	1	2
CompactFlash	-	-	1	1
PMC or XMC	1	via J4	4/1	1
Floppy	-	1	-	1

CompactPCI Bus Interface
 » PICMG 2.0 Rev. 3.0 compatible, 64-bit / 66 MHz
 » 5V or 3.3V signalling, REQ/GNT for 7 slots
 » Operating in system slot as system master and in peripheral slot in PCI passive mode (no communication to CPCI bus)

PMC/XMC Slot
 » One 64-bit / 66MHz PMC slot, Pn1-Pn4, rear I/O Pn3 to J4, 3.3 V PCIvoltage
 » Alternatively one XMC slot via P15, supporting XMC.3 x8 PCIExpress

Supervisory Functions, Clock/Calendar
 » Watchdog, software configurable, 125 msec to 256 sec, generates IRQ, NMI or hardware reset
 » Hardware monitor for thermal control, fan speed, and all onboard voltages
 » RTC (integrated in 6300ESB) and CMOS RAM with backup, battery replaceable

Rear I/O via J3/J4/J5
 » J3: PICMG 2.16, VGA, COM 1/2, keyboard, mouse, USB 3/4
 » J4: PMC rear I/O
 » J5: SATA 1/2, IDE (secondary)

IPMI IPMI 1.5-compliant for IPMI based management and CompactPCI System Management PICMG 2.9 R1.0

Compliance
 » CompactPCI Core Specification PICMG 2.0 Rev. 3.0
 » CompactPCI Hot Swap Specification PICMG 2.1 R2.0
 » CompactPCI System Management PICMG 2.9 R1.0
 » CompactPCI Packet Switching Backplane PICMG 2.16 R1.0
 Designed to meet or exceed:
 » Safety: UL 1950, UL 94, CSA 22.2 No 950, EN 60950, IEC 950
 » EMI/EMC: EN 55022 / EN 55024, EN 50081-1 / EN 6100-6-2

General

Dimensions	233 x 160 x 20.5 mm, 6U, 4HP
Weight	400g
MTBF	157,696h @ 30°C / 86°F (Bellcore Issue 6)

Technical Information

Software Support	<ul style="list-style-type: none"> » AMI BIOS with POST codes, setup console redirection to serial port (VT100 mode) with CMOS setup access, BIOS parameters saved in EEPROM, diskless, keyboardless, videoless operation » LAN boot support » Board identification number accessible via EEPROM » Support for Windows® XP, XP Embedded, Windows® Server 2003, Linux®, VxWorks (other OSs may be possible, please contact us for information)
Power Consumption	CP6012 equipped with 2GB memory: <ul style="list-style-type: none"> » LV 1.66 GHz: max 34 W » 2.0 GHz: max 52 W
Environmental	
Operating temp.	0°C to +60°C standard with LV 1.66 GHz (with forced airflow)
Storage temp.	- 55°C to + 85°C (without battery or HDD)
Climatic Humidity	93% RH at 40°C, non condensing (acc. to IEC 60068-2-78)
Altitude	50,000 ft (15,240 m)

Ordering Information

Article	Order-No.	Description
CP6012	34567	Intel® Core™ Duo L2400 LV 1.66 GHz, 2xGigEthernet on FP, 2xGigEthernet on PICMG2.16/RIO, 5V I/O
CP6012	35324	Intel® Core™ Duo L2400 LV 1.66 GHz, 2xGigEthernet on FP, 2xGigEthernet on PICMG2.16/RIO, 3.3V I/O
CP6012	1021-9624	Intel® Core™ Duo T2500 2.0 GHz, 2xGigEthernet on FP, 2xGigEthernet on PICMG2.16/RIO, 5V I/O
CP6012	1021-9625	Intel® Core™ Duo T2500 2.0 GHz, 2xGigEthernet on FP, 2xGigEthernet on PICMG2.16/RIO, 3.3V I/O
Memory Modules		
SODIMM-DDR2-512-ECC	33473	512MB, SODIMM, DDR2 SDRAM, PC400, 200-pin, registered ECC
SODIMM-DDR2-1G-ECC	33474	1GB, SODIMM, DDR2 SDRAM, PC400, 200-pin, registered ECC
SODIMM-DDR2-2G-ECC	34847	2GB, SODIMM, DDR2 SDRAM, PC400, 200-pin, registered ECC
Services		
CP6-RIO-216	27829	Assembly of connectors J4/J5 and rear IO configuration for CP6012
CP6-RIO-216-NOJ4	27830	Assembly of connector J5 (no J4) and rear IO configuration for CP6012
CP6012-MK2.5SATA ¹⁾	33477	Mounting kit for 2,5" SATA-HDD onboard, mounting within 4HP
Rear Transition Modules		
CP-CTM80-3		Various 4HP versions available
Software Support		
KIT-CP6012 ²⁾	33475	Documentation and Windows driver kit on CD-ROM
LIN-BSP-CP6012 ²⁾	33476	Linux BSP CP6012 for Suse and RedHat
VXW-BSP-CP6012	36157	VxWorks 6.4 BSP CP6012 with single core support
VXW-BSP-CP6012-SMP	1021-9791	VxWorks 6.6 BSP CP6012 with SMP support

1) HDD must be ordered separately

2) Free of charge, downloadable from the Internet

Please contact your local sales representative for other configuration options.

CORPORATE OFFICES

Europe, Middle East & Africa

Oskar-von-Miller-Str. 1
85386 Eching/Munich
Germany

Tel.: +49 (0)8165/ 77 777
Fax: +49 (0)8165/ 77 279
info@kontron.com

North America

14118 Stowe Drive
Poway, CA 92064-7147
USA

Tel.: +1 888 294 4558
Fax: +1 858 677 0898
info@us.kontron.com

Asia Pacific

17 Building, Block #1, ABP.
188 Southern West 4th Ring Road
Beijing 100070, P.R.China

Tel.: + 86 10 63751188
Fax: + 86 10 83682438
info@kontron.cn

