

» ITC-320 «

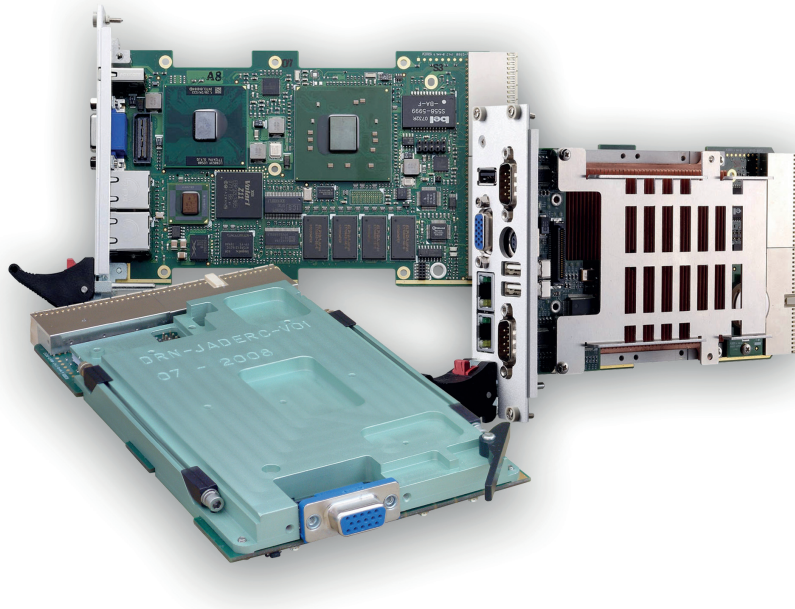

Rugged Blade PC

- » Performance/Dissipation matching your application
- » Highest Versatility: PCIe, SATA, Gigabit Ethernet, Graphics, USB, GPIO
- » Air-Cooled and Rugged Conduction-Cooled builds
- » 10-Year Long Life Cycle

The Kontron's ITC-320 series expands Kontron' Intel® single and multi-core blade SBC portfolio with a set of full- fledge I/O embedded PCs enabling the design of cost effective, high performance embedded computers to meet the new challenges in transport, medical and defense applications. The ITC-320 series use long life cycle chipsets from the Intel® Embedded Architecture in order to protect customers investments.

Three Soldered CPUs to better match customers' requirements:

Intel® Celeron®-M ULV

Running at 1.07 GHz for low power dissipation, this single core processor features 1 MB of on-die Level 2 cache and a 533 MHz Front Side Bus (FSB).

Intel® Core™ Duo LV

Running at 1.2 GHz, this CPU is a good compromise between performance and power dissipation. The Intel® Core™ Duo is a dual-core processor which features a large on-die 2 MB Level 2 cache and support a 533 MHz FSB. For image and digital image processing applications, the Intel® Core™ Duo supports the MMXTM™ technology enhanced with streaming SIMD instructions Extensions 2 and 3 (SSE2 and SSE3).

Intel® Core™2 Duo LV

Running at 1.5 GHz, this CPU is the best choice for intensive data and signal processing. The Intel® Core™2 Duo is a dual-core processor which supports Intel® 64 architecture and full compatibility with IA-32 software. A large on-die 4 MB Level 2 cache with Advanced Transfer Cache Architecture and Supplemental Streaming SIMD Extensions 3 (SSSE3) make the Intel® Core™2 Duo an extremely efficient processor for Digital Signal Processing applications. The Intel® Core™2 Duo features a 667 MHz FSB. Thanks to its exceptional thermal efficiency, the ITC320 has been qualified to operate the processor at a continuous maximum speed of 1.5 GHz at temperatures up to +75°C (wedgelock interface) and at a speed of 1,3GHz for temperatures up to +85°C. Under such conditions, ITC320 guarantees constant computing performance for computer designed to match VITA 47 CC3 or CC4 standards.

Soldered DDR2 Memory with the support of ECC for a better reliability

The ITC-320 is available with 1 GB of DDR2-400 SDRAM. 2 GB is available on demand. The SDRAM is managed by the integrated Memory Controller Hub and I/O Controller Hub (IMCH and IICH) Intel® 3100. Error Correction and Control (ECC) feature is supported by the IIMCH.

Outstanding number of storage interfaces

- » The ITC-320 features four SATA-150 ports to interface with a large number of devices. Three are available on the rear J2 connector, and the fourth is routed on the 8HP option for connecting a 2.5" hard disk drive.
- » In addition, the ITC-320 support an USB 2.0 Low-Profile Flash Disk module. Three USB 2.0 ports are available, one on the front panel (to easily download files from external devices) and two on the rear J2 connectors. Two additional USB 2.0 ports are available on the 8HP build version front panel.

Configurable Dual Gigabit Ethernet ports

The Dual Gigabit Ethernet controller is directly interfaced to the IIMCH using a PCI Express® x4 link in order to provide an optimum throughput. The two ports can be software configured to be routed either on the front (on RJ-45 connectors) or on the rear (J2 connector) on easy to connect PICMG 2.16 type pin-out. The rear Gigabit Ethernet ports are routed to two RJ 45 connectors on the Rear Transition Module (RTM).

CompactPCI® backplane supporting PCI Express® x4 or 4x1 interfaces

- » The ITC-320 meets the CompactPCI® PICMG 2.0 Rev. 3.0 compatible recommendation. It features a system master PCIbus 32-bit/33 MHz interface able to drive 7 peripheral slots. When several ITC-320 are planned to be plugged onto the same cPCI bus, a satellite version, without PCIbus shall be used. Please, contact Kontron.
- » When high throughput, PCI compliant interfacing is required, the ITC-320 features a PCI Express® port x4 configurable as four x1 links onto rear J2 connector. In order to guaranty an optimum signal integrity of the PCI Express® link, the ITC-320 can be provided with a 5 GHz HSHM connector. Please, contact Kontron.

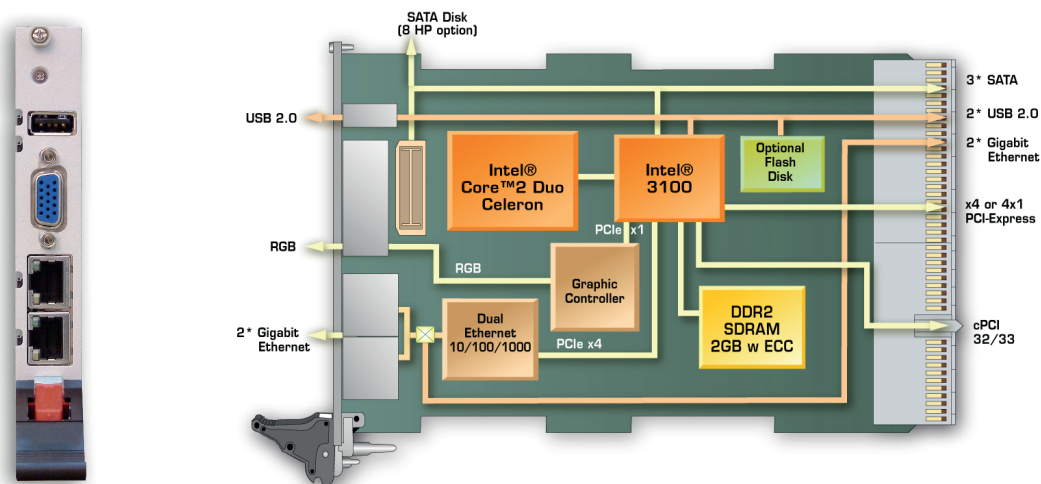

Supervisory Functions

The integrated IMCH features watchdog timer and RTC which meets embedded use. In addition, the I2C port of the IMCH of the ITC-320 is accessible of the rear J2 connector at the standard IPMI pin-out, to ease shelf management monitoring.

Designed to meet the requirements of harsh environments

The ITC-320 has been designed so that the same PCB can be used in various builds able to meet a wide range of operating temperatures, from -40°C to +85°C, VITA 47 CC4 temperature class. The ITC-320 exists in a rugged conduction-cooled version for being used in harsh environments. The ITC-320 featuring the Intel® Core™2 Duo LV processor has been qualified at maximum processor speed of 1.5 GHz to meet VITA 47 CC3 operating temperature range up to +75°C.

10-Year Long Life Cycle

Investing in a new project is always a challenge and risky. Extending the lifetime of an application to the possible maximum is therefore a critical issue to save the development investments. The ITC-320 has been designed with long life cycle components. Beyond the standard commercial availability of components, Kontron offers services able to procure products over 10 years.

Unique Features

- » Fully soldered components for higher shock vibration resistance
- » PCI Express® connectivity on backplane(HSHM connector option required)
- » Quad SATA-150 interfaces
- » 10-year long life cycle
- » Rugged Conduction-cooled version

Technical Information

System processor

Onboard soldered processor as build option:
 » Intel® Core™2 Duo LV (L7400) 1.5 GHz, 4 MB L2 cache, SSE3, 667 MHz FSB, 17W
 » Intel® Core™ Duo (U2500) 1.2 GHz, 2 MB L2 cache, 533 MHz FSB, 9W
 » Intel® Celeron® M Proc ULV(423) 1.07 GHz, 1 MB L2 cache, 533 MHz FSB, 5.5W
 » Passive cooling for all builds within 4HP height.
 » Forced air cooling at specific flow rate is required depending on the processor version.

Integrated Chipset

Intel® 3100 integrated MCH (Memory Controller Hub) and ICH (I/O Controller Hub).

FSB port to processor

533/667 MHz

Watchdog Timer

2-stage, system reset and nmi Programmable Timer

RTC

Integrated in chipset

GPIOs

7 available on rear J2

Memory

System Memory

1 GB of DDR2-400 with ECC - 2 GB available on request

System Flash

16 Mbit FWH Flash Memory

User Flash

Socket for USB Flash Disk, Low Profile, 2.54 pitch connector, 4, 8 and 16 GB sizes are available

HDD

Onboard 2.5" SATA mounting within 8HP mezzanine

I/O Connectors

Gigabit Ethernet

Dual Ports configurable either on front RJ-45 or rear J2. PCI-e x4 interface to host

Graphics

64-bit 2D graphics engine on PCI-e x1. VGA graphics connector available as option in RC build for use in extended operating temperature from -20°C. Analog VGA interface on front. Associated 32 MB of DDR2 SDRAM. Integrated 24-bit true-color RAMDAC with 230 MHz pixel clock.

CompactPCI Interfaces

PICMG 2.0 Rev. 3.0 compatible
 32-bit/ 33 MHz PCIbus
 5 V or 3.3 V PCI signaling from backplane
 System Slot only
 Supports up to 7 devices
 Drone mode (or ‚Satellite‘, ie. without PCIbus) option on request

Front Panel Interfaces

4HP Air Cooled

Ethernet (x2): RJ-45 with LEDs; VGA: VGA-CRT 15-pin D-Sub connector; USB: 4-pin Type-A connector; Control: Reset button, LEDs

8HP Air Cooled
(In addition to 4HP)

COM 3,4 (x2): 9-pin D-Sub connectors
 USB (x2): 4-pin Type-A connector
 PS/2: 6-pin mini-DIN connector

Rear I/O via J2

Two USB 2.0 ports
 Two Gigabit Ethernet Ports
 Three SATA-150 Ports
 Two TTL-level COM ports
 Seven GPIOs
 I2C Management bus
 PCI Express® x4 Port, configurable in 4x1 (HSHM connector option required)

Power Consumption

Under WindowsXP: Idle / 100 % CPU
 » Intel® Core™2 Duo 1.5 GHz: 29 W / 36 W
 » Intel® Core™ Duo 1.2 GHz: 24 W / 27 W
 » Intel® Celeron® M 1.07 GHz: 22 W / 24 W

Environmental Specifications

	SA Standard Commercial	RC Rugged Conduction-Cooled
Conformal Coating	Optional	Standard
Airflow	1.5 m/s without throttling at 55°C	NA
Temperature	VITA 47-Class AC1	VITA 47-Class CC4 (CC3 full speed for Intel® Core™2 Duo)
Cooling Method	Convection	Conduction
Operating	0° to +55°C	-40° to +85°C (CC4) or +75°C (CC3)
Storage	-45° to +85°C	-45° to +85°C
Vibration Sine (Operating)	20/500 Hz: 2g	22/2,000 Hz: 2g
Random	VITA 47-Class V1	VITA 47-Class V3
Shock (Operating)	20g/11 ms Half Sine	40g/11 ms Half Sine
Altitude (Operating)	1,640 to 15,000 ft	-1,640 to 50,000 ft
Relative Humidity	90% without condensation	95% without condensation

Ordering Information

Article	SA Standard Commercial	RC Rugged Conduction-Cooled
ITC-320	ITC320-SA52-00000	4HP, Intel® Core™2 Duo (L7400) 1.5 GHz, 4MB L2, 1GB SDRAM
ITC-320	ITC320-SA22-00000	4HP, Intel® Core™ Duo (U2500) 1.2 GHz, 2MB L2, 1GB SDRAM
ITC-320	ITC320-SA02-00000	4HP, Intel® Celeron® M (423) 1.07 GHz, 1MB L2, 1GB SDRAM
ITC-322	ITC322-SA52-00000	8HP, Intel® Core™2 Duo (L7400) 1.5 GHz, 4MB L2, 1GB SDRAM
ITC-322	ITC322-SA22-00000	8HP, Intel® Core™ Duo (U2500) 1.2 GHz, 2MB L2, 1GB SDRAM
ITC-322	ITC322-SA02-00000	8HP, Intel® Celeron® M (423) 1.07 GHz, 1MB L2, 1GB SDRAM
ITC-320	ITC320-RC52-00000	4HP, Intel® Core™2 Duo (L7400) 1.5 GHz, 4MB L2, 1GB SDRAM
ITC-320	ITC320-RC52-G0000	4HP, Intel® Core™2 Duo (L7400) 1.5 GHz, 4MB L2, 1GB SDRAM, version with VGA (-20°C to +75°C)
ITC-320	ITC320-RC22-00000	4HP, Intel® Core™ Duo (U2500) 1.2 GHz, 2MB L2, 1GB SDRAM
ITC-320	ITC320-RC02-00000	4HP, Intel® Celeron® M (423) 1.07 GHz, 1MB L2, 1GB SDRAM
RTM	PB-IT3-000	Rear Transition Module
USB Flash Disk	FDM-USB-4GB-00	4GB USB Flash Disk Module
USB Flash Disk for RC	FDM-USB-4GB-IV	4GB USB Flash disk for use in RC environments
Rack	RTOP-4S200-00	4-slot 200W Development Rack
VGA tool	ADAP-VGA	Tooling board with VGA connector for IEEE -RC boards

CORPORATE OFFICES

Europe, Middle East & Africa

Lise-Meitner-Str. 3-5
86156 Augsburg
Germany

Tel.: +49 (0) 821 4086-0
Fax: +49 (0) 821 4086 111
sales@kontron.com

North America

14118 Stowe Drive
Poway, CA 92064-7147
USA

Tel.: +1 888 294 4558
Fax: +1 858 677 0898
info@us.kontron.com

Asia Pacific

17 Building, Block #1, ABP.
188 Southern West 4th Ring Road
Beijing 100070, P.R.China

Tel.: +86 10 63751188
Fax: +86 10 83682438
info@kontron.cn