

Kontron VX30101

High-End 3U VPX Computing Board

Designed for AI-enabled mission computing, sensor fusion and rugged embedded server applications

Intel® Core Ultra Series 3, up to 64 GByte LPDDR5x memory with ECC, 100Gb Ethernet Data Plane port, Air & Rugged Conduction-cooled variants, designed in accordance with SOSA® Standard

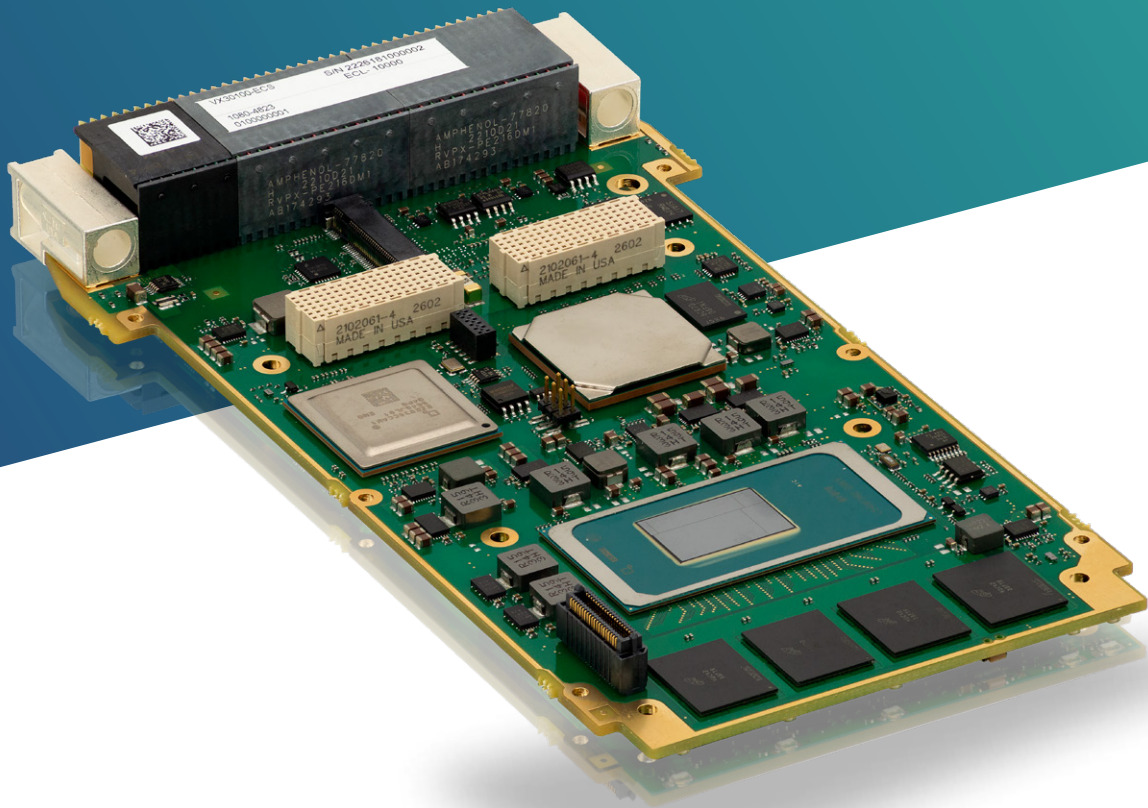

3U VPX High End Computing Board

The Intel® Core Ultra Series 3 Platform

Bringing together next-generation hybrid CPU cores, integrated Xe graphics and a dedicated NPU, Intel Core Ultra Series 3 gives the VX30101 the right balance of general-purpose compute, AI acceleration and I/O integration for rugged edge systems.

Targeting AI-assisted sensor processing, mission servers and low-SWaP compute nodes, the platform combines high-speed Ethernet fabrics, PCI Express connectivity and low-latency memory in a single 3U VPX payload card architecture. This enables system designers to consolidate workloads previously distributed across multiple boards.

Depending on the selected SKU, the VX30101 can support up to 16 cores and Intel AI acceleration resources, making it well suited to autonomy support, computer vision, data reduction, sensor fusion and command-and-control applications that require deterministic I/O and rugged deployment.

The SOSA® Architecture Booster

Kontron VX30101 provides an instant performance uplift for next-generation HPEC architectures designed in accordance with SOSA® technical standard principles. By combining a modern Intel Core Ultra platform with a rugged single-slot 3U VPX design, the VX30101 delivers a practical migration path for legacy compute blades while preserving system-level modularity.

Being developed in compliance with SOSA®-aligned OpenVPX profiles, the module benefits from profile interoperability and open-system integration practices, reducing both development risk and platform lifecycle costs for integrators.

The VX30101 is planned with the following slot and module profiles:

- › Slot Profile: SLT3-PAY-1F1F2U1TU1T1U1T-14.2.16
- › Module Profile: MOD3-PAY-1F1F2U1TU1T1U1T-16.2.15-4

Optional TSN Networking Acceleration

For next-generation defense embedded systems, Time-Sensitive Networking (TSN) brings key advantages by adding deterministic behavior to standard Ethernet infrastructures. In applications such as avionics mission computing, sensor fusion, distributed processing, and real-

time vehicle or platform networking, TSN helps improve synchronization accuracy, control end-to-end latency, and ensure more predictable traffic delivery under mixed and heavily loaded network conditions. These capabilities are particularly valuable for architectures targeting alignment with aerospace Ethernet frameworks such as IEEE 802.1DP, where interoperability, timing determinism, and network robustness are increasingly important.

The VX30101 is designed with a forward-looking roadmap to address these emerging requirements in a future product revision. This option is planned to provide two 10GBASE-KR backplane ports with TSN support, targeting applications that require deterministic Ethernet transport in addition to high-performance computing. Customers with roadmap requirements for TSN or aerospace 802.1DP-oriented architectures are encouraged to contact Kontron for availability and configuration details.

Reliability and Robustness

The VX30101 is available in both air-cooled and conduction-cooled variants for deployment in harsh embedded environments. The air-cooled version is optimized for lab, shelter, and vehicle applications where forced-air cooling is available, while the conduction-cooled version is specifically intended for the most rugged, mission-critical deployments, leveraging VITA 48-style plug-in unit mechanics for operation in highly constrained and severe conditions.

Depending on configuration and thermal design margin, the product family targets extended operating temperatures up to -40°C to +85°C at the card edge, along with long-life component selection and a product longevity objective of 10 years or more.

Cyber Security, Secure Deployments

VX30101 is designed to support secure deployment strategies with a discrete TPM 2.0 hardware root of trust, support for secure boot and measured boot, firmware recovery concepts and hardware write-protection mechanisms for critical non-volatile devices. These capabilities help system designers implement trusted boot chains and protect mission data across the lifecycle.

3U VPX High End Computing Board

Typical Applications

4ISR and Tactical Systems

Real-time sensor fusion, mission networking and data processing at the tactical edge.

Mission Computing

Rugged embedded server node for land, air and naval platforms under strict SWaP-C constraints.

Electronic Warfare & Radar Processing

AI-assisted signal exploitation, fast data movement and deterministic control-plane connectivity.

Tactical Communications

Secure, high-bandwidth edge routing and network function consolidation.

System Upgrades

Natural migration path from earlier-generation VPX compute blades to modern AI-capable SOSA®-oriented architectures.

Block Diagram

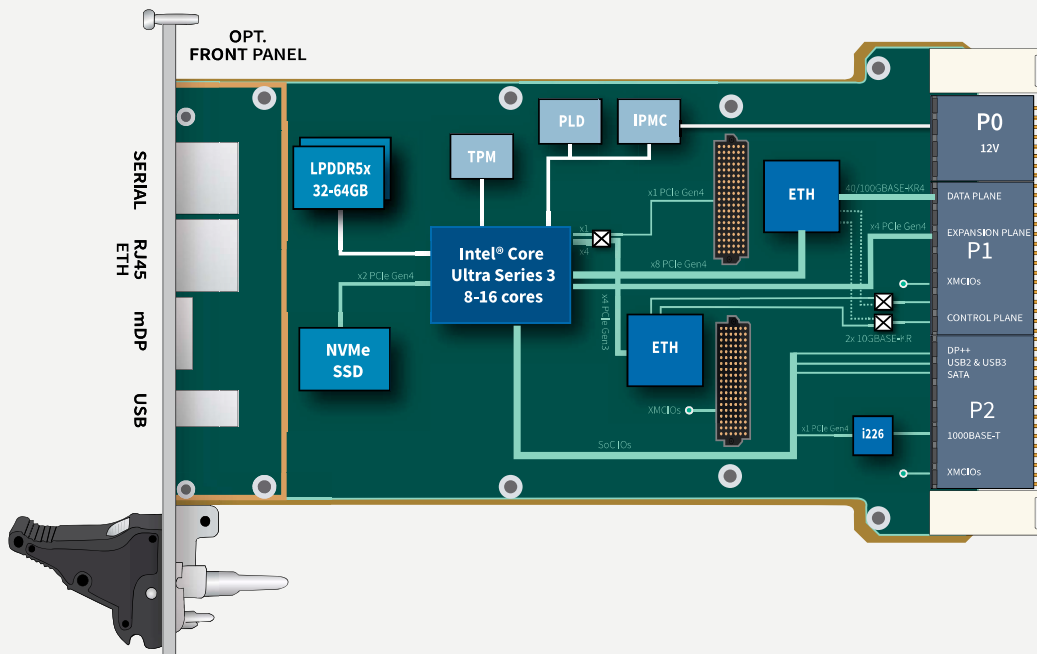

Technical Information

Form Factor		3U VPX
Processor	CPU	Intel Core Ultra Series 3, up to 16 cores depending on selected SKU, integrated NPU and Xe graphics, power class TBD by final configuration
Memory	System Memory	32-64 GByte dual-channel LPDDR5x SDRAM with in-band ECC
On-Board Features	Board Management System CPLD	IPMI controller for VITA46.11 Tier3 support and out-of-band system management. Handles power sequencing, monitoring, RESET, LEDs and platform control resources
	TPM	TPM 2.0 device
	Non-Volatile Memories	Boot FLASH devices with recovery image and UEFI BIOS settings, F-RAM and user/system EEPROM
	Sensors	Voltage, Temperature & Current sensors
Storage	NVMe SSD (through M.2 slot)	Up to 1 TByte NVMe SSD option
Expansion Slots	XMC Site	x1 or x4 PCIe Gen4-capable XMC expansion slot (depending on product configuration)
Front Panel	IOS	Serial maintenance port, USB3.1, RJ45 1000/2500BASE-T and mDisplayPort (on air-cooled variant only)
Backplane	Data Plane	40/100GBASE-KR4
	Expansion Plane	x4 PCIe up to Gen4
	Control Planes	Dual 10/25GBASE-KR + 2500BASE-T ports
	IOS	Maintenance port on RS232 or LVCMOS levels, SATA for storage, DP++, USB2.0 port, USB3.2 port, dual serial lines, GPIOs, XMCIOs, dual SMB/IPMB, JTAG and power supplies
Standard Profile	Slot Profile	SLT3-PAY-1F1F2U1TU1T1U1T-14.2.16
	Module Profile	MOD3-PAY-1F1F2U1TU1T1U1T-16.2.15-4 MOD3-PAY-1F1F2U1TU1T1U1T-16.2.15-2
Software	BIOS	UEFI BIOS
	BSP	Linux BSP. Windows and VxWorks on demand
	POST	Power-On Self Tests
	PBIT	BIOS health PBIT with system change detection
	Optional : CBIT	Health monitoring engine for remote or local use
Availability		Up to 10 years

Environmental Specification

	SA - Air Cooled Version	RC - Rugged Conduction Cooled Version
Conformal Coating	No	Standard
Airflow	tbd	na.
Cooling Method	Convection	Conduction
Operating Temperature	0°C to +55°C	-40°C to +85°C
Storage Temperature	-40°C to +85°C	-50°C to +100°C
Vibration Sine (Operating)	20-500 Hz - 2g	20-2000 Hz - 5g
Random	0.04g2/Hz 5-100 Hz	5-100 Hz : PSD = +3dB/octave 100-1000 Hz : PSD = 0.1g2/Hz 1000-2000 Hz : PSD = -6dB.octave
Shock (Operating)	20g/11 ms Half Sine	40g/11 ms Half Sine
Altitude (Operating)	-1.500 to 60.000 ft	-1.500 to 60.000 ft
Relative Humidity	90% without condensation	95% without condensation

Ordering Information

Environmental Class	Article	Part Number	Description
SA	VX30101-SA4H-000F01V1P		3U IO Intensive Single slot VPX Plug-In Card -Air-Cooled 'SA' (0°C to 55°C) - Intel® Core™ Ultra Series 3 H484-4Xe (366HRE) - 64GB soldered LPDDR5x with IECC - no VITA 48 2LM covers - XMC Mezzanine Slot on x1 PCIe (VITA42, up to Gen4) - Rear module profile is MOD3-PAY-1F1F2U1TU1T1U1T-16.2.15-4: 100/40GbE Data Plane, x4 PCIe up to Gen4 Expansion Plane, dual 10GbE + 1GbE Control Planes - Front panel connectors through a mezzanine board providing one serial line, one USB3.1 port, one mDP port and one RJ45 1000Base-T Ethernet. - Top 2242 M.2 slot : up to D5 and M Key with x4 PCIe up to Gen3 - RTC Power sourced from battery module - VITA 46.11 Support - TPM 2.0 Secure element - Power on Built in Test Run Time
RC	VX30101-RC44H-00N00V1P		3U IO Intensive Single slot VPX Plug-In Card -1" Conduction-Cooled 'RC4' (-40°C to +85°C) conformal coating - Intel® Core™ Ultra Series 3 H484-4Xe (366HRE) - 64GB soldered LPDDR5x with IECC - no VITA 48 2LM covers - XMC Mezzanine Slot on x1 PCIe (VITA42, up to Gen4) - Rear module profile is MOD3-PAY-1F1F2U1TU1T1U1T-16.2.15-4: 100/40GbE Data Plane, x4 PCIe up to Gen4 Expansion Plane, dual 10GbE + 1GbE Control Planes - No Front I/O connectors - Top 2242 M.2 slot : up to D5 and M Key with x4 PCIe up to Gen3 - RTC Power sourced from system VPX VBAT - VITA 46.11 Support - TPM 2.0 Secure element - Power on Built in Test Run Time
	VX30101-RC42G-00N00V1P		3U IO Intensive Single slot VPX Plug-In Card -1" Conduction-Cooled 'RC4' (-40°C to +85°C) conformal coating - Intel® Core™ Ultra Series 3 H404-4Xe (365RE) - 32GB soldered LPDDR5x with IECC - no VITA 48 2LM covers - XMC Mezzanine Slot on x1 PCIe (VITA42, up to Gen4) - Rear module profile is MOD3-PAY-1F1F2U1TU1T1U1T-16.2.15-4: 100/40GbE Data Plane, x4 PCIe up to Gen4 Expansion Plane, dual 10GbE + 1GbE Control Planes - No Front I/O connectors - Top 2242 M.2 slot : up to D5 and M Key with x4 PCIe up to Gen3 - RTC Power sourced from system VPX VBAT - VITA 46.11 Support - TPM 2.0 Secure element - Power on Built in Test Run Time

Please ask sales.kfr@kontron.com for a specific configuration.

Related Products

RTM (Rear Transition Module)

The Kontron PB-VX3-40G-602 is a 3U VPX Rear Transition Module compliant with the VPX Standard - VITA 46.10.

It provides rear I/O peripherals connectivity such as serial lines, USB2.0 and USB3.0, SATA, 1000Base-T Ethernet, mDP++ connectors and a SFP+ cage.

This RTM is a tooling equipment for lab use only.



Kontron Modular Computers S.A.S.

150 rue Marcellin Berthelot
ZI de Toulon-Est - BP 244
83078 Toulon Cedex 9
France

Tel.: + 33 4 98 16 34 00
sales.KFR@kontron.com
www.kontron.com

More
Information

