

Kontron VX307C

# High-End 3U VPX Computing Board

**Designed for Imaging, Radar and Embedded Server Applications**

8 and 10-Core™ Xeon® D-1700/1800 SoC running at 2.0 GHz, up to 64 GByte DDR4 memory with ECC, 100Gb Ethernet Data Plane port, Rugged Air & Conduction-cooled Variants, designed in accordance with SOSA® Standard

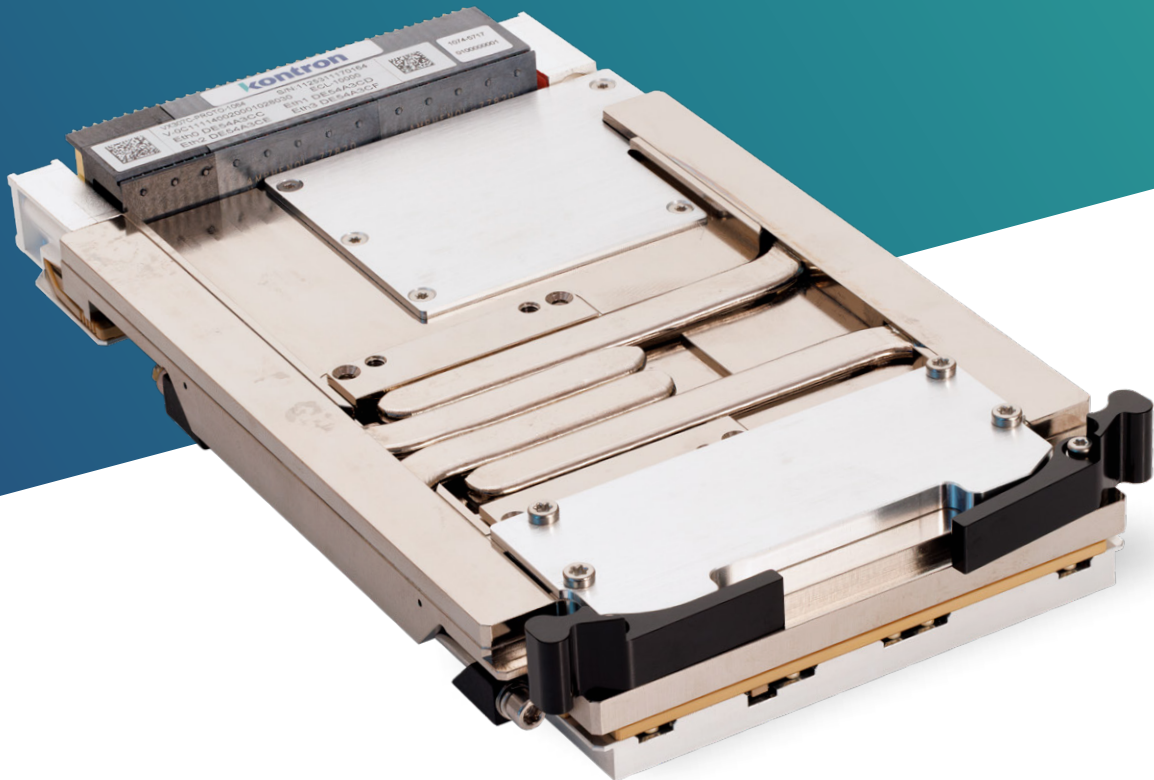

# 3U VPX High End Computing Board

## The Intel® Xeon® D-1700/1800 Platform

Outperforming the previous Intel® Xeon®-D 1500 SOC silicon, the 10nm Intel® Xeon® D-1700 SOC of the VX307C targets a new generation of microserver and parallel computing node with superb performance, improved again with D-1800 processors family with a reasonable power budget. Offering capabilities such as PCIe gen4, 100Gb Ethernet with ROCE V2 RDMA protocol and on chip DMA engine, VX307C is a perfect fit for blade computing being the most powerful product ever offered. It fulfills the growing computing and I/O requirements of leading edge applications that target a minimum number of boards.

Available in 8-core and 10-core versions, these SKUs both offer extended operating temperatures and 10-year availability, the 10-core version being available until 2034.

With specialized instructions for Artificial Intelligence (VNNI), Signal Processing (AVX512) and crypto algorithms, Computer vision, media processing and crypto applications enjoy twice the performance of the previous generation of micro server SOCs. All versions support the ROCE V2 RDMA feature at the silicon level.

## The SOSA® Architecture Booster

Kontron VX307C computing node provides an instant boost to the computing performance of existing HPEC architectures designed in accordance with SOSA®.

With the VX307C, Kontron takes this outstanding silicon architecture to the next level, in the form of a rugged single 3U VPX board server, boasting numerous innovations and extensions designed to fulfill the most demanding mission profiles.

Being developed in compliance with the SOSA® standard, the module takes advantage of the profiles interoperability offered by the standard, making the VX307C the perfect building block at system level, reducing costs and development time for integrators.

The VX307C is available with the following slot & module profiles :

- › SLT3-PAY-1F1F2U1TU1T1U1T- 14.2.16
- › MOD3-PAY-1F1F2U1TU1T1U1T-16.2.15-4
- › MOD3-PAY-1F1F2U1TU1T1U1T-16.2.15-2

## Reliability and Robustness

The selected CPU SKU reliability is guaranteed for 10 years up to 100 % active usage profile.

VX307C Rugged Conduction cooled version is a Plug-in unit that can sustain from -40 °C up to 85 °C card edge temperature according to VITA 47 depending on the processing load and mezzanine power. It is available with the VITA 48 REDI Two-Level Maintenance bottom cover as an option.

## Cyber Security, Secure Deployments

VX307C design is compatible with the Kontron SEC-Line elements and features a discrete TPM2 hardware root of trust. It supports secure boot, measured boot and hardware protection of crypto keys.

### Typical Applications

#### 4ISR and Tactical Systems

Real-time sensor fusion, secure mission networking, and data processing at the tactical edge.

#### Mission Computing

Rugged embedded server for land, air, and naval platforms under strict SWaP-C constraints.

#### Electronic Warfare & Radar Processing

Parallel signal processing and high-speed data handling for EW and ISR payloads.

#### Tactical Communications

Secure, high-bandwidth connectivity and edge routing in distributed command networks.

#### System Upgrades

Natural migration path from legacy Broadwell-D systems to modern SOSA®/MOSA architectures.

## Block Diagram

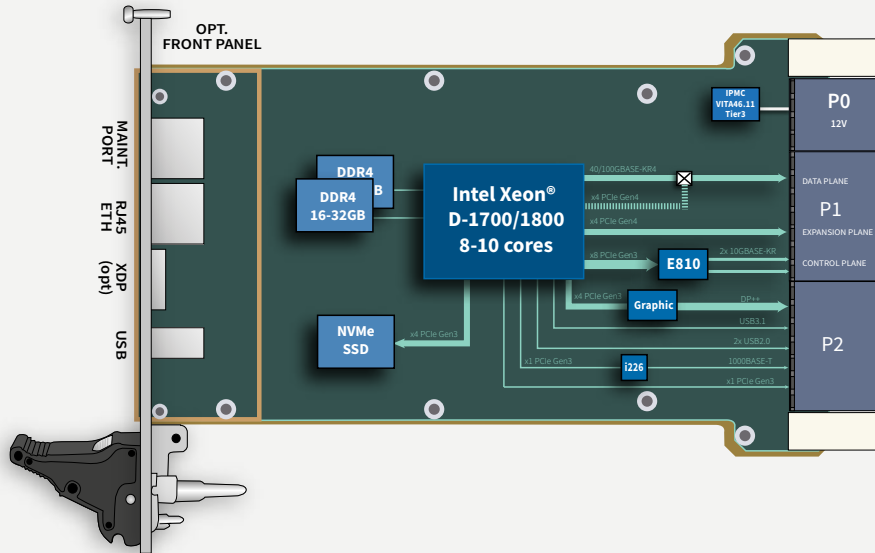

## Technical Information

<b>Form Factor</b>		3U VPX
<b>Processor</b>	CPU	Intel® Xeon®- D-1732TE, 8-core/16 threads, 15MByte cache, 1.9 GHz/3.0 GHz Turbo, 52W TDP Intel® Xeon®- D-1848TER, 10-core/20 threads, 20MByte cache, 2.0 GHz/3.10 GHz Turbo, 57W TDP
<b>Memory</b>	System Memory	32-64 GByte dual channel DDR4 SDRAM with ECC
<b>On-Board Features</b>	Board Management System CPLD	IPMI Controller for VITA46.11 Tier3 support and Out-of-Band System Management The CPLD handles all the system management resources such as power supplies, monitoring, RESET, LEDs etc...
	TPM	TPM 2.0 device
	Non-Volatile Memories	2x 512Mb boot FLASH devices, with recovery image and uEFI BIOS settings 1Mb F-RAM 2x 512Kb User/System EEPROM
	Sensors	Voltage, Temperature & Current sensors
<b>Expansion Slots</b>	M.2 Slot	x4 PCIe Gen3 link connected to M.2 2242 up to D5 and M Key socket
<b>Front Panel</b>	IOS	1000BASE-T Maintenance port on RS232 or LVCMOS levels DP++ USB3 USB2
<b>Backplane</b>	Data Plane Expansion Plane Control Planes IOS	40/100GBASE-KR4 ports x4 PCIe up to Gen4 Dual 10GBASE-KR + 1000BASE-T ports Maintenance Port on RS232 or LVCMOS levels x1 PCIe Gen3 / SATAIII for storage DP++ 1.4 Graphic port USB2.0 ports USB3.0 ports Dual serial lines GPIOs XMCIOs Dual SMB/IPMB, JTAG, Power Supplies
<b>Standard Profile</b>	Slot Profile Module Profile	SLT3-PAY-1F1F2U1TU1T1U1T- 14.2.16 MOD3-PAY-1F1F2U1TU1T1U1T-16.2.15-4 MOD3-PAY-1F1F2U1TU1T1U1T-16.2.15-2
<b>Software</b>	BIOS BSP POST PBIT  Optional : CBIT	UEFI BIOS Linux BSP, tested with Fedora. Windows, VxWorks on demand Power-On Self Tests CMON PBIT EXPERT: BIOS Health PBIT, with system change detection (learn and compare method, no programming) CMON MONITORING: Linux health Monitoring engine. Creates Continuous flow of health data from customizable test points for remote or local use
<b>Availability</b>		Up to 10 years

## Environmental Specification

	RA-Rugged Air Cooled Version	RC - Rugged Conduction Cooled Compliant With Type 1 Plug-In Unit 2 Level Maintenance As per Vita48.0 and Vita48.2 Standards
Conformal Coating	Standard	Standard
Airflow	tbd	na.
Cooling Method	Convection	Conduction
Operating Temperature	-40 °C to +70 °C	-40°C to +85°C
Storage Temperature	-50 °C to +100 °C	-50 °C to +100 °C
Vibration Sine (Operating)	20-2000 Hz - 3 g	20-2000 Hz - 5 g
Random	VITA 47-Class V2	VITA 47-Class V3
Shock (Operating)	40 g/11 ms Half Sine	40 g/11 ms Half Sine
Altitude (Operating)	-1.500 to 60.000 ft	-1.500 to 60.000 ft
Relative Humidity	90% without condensation	95% without condensation

## Ordering Information

Environmental Class	Article	Part Number	Description
RC	<b>VX307C-tuv-wxy00V1z</b> VX307C-RC308G-00N00V1P VX307C-RC308G-00N00V1Q VX307C-RC411H-00N00V1P VX307C-RC411H-00N00V1Q VX307C-RC411H-01N00V1P VX307C-RC411H-01N00V1Q	1075-2514 1075-2516 1075-2519 1075-2521 1080-5163 1080-5164	3U single slot 5 HP (1.0") VPX CPU Blade with Intel® Xeon® D-1700/1800 processor series, <b>rugged conduction cooled</b> with conformal coating  <b>Available options:</b> <ul style="list-style-type: none"> <li>› Thermal performance t=RC3: -40°C to +70°C board edge temperature t=RC4: -40°C to +85°C board edge temperature</li> <li>› Processor type: u=08: 8-Core D1732, base frequency 2.0 GHz, TDP 52 W u=11: 10-Core D-1848TER, frequency 2.0 GHz, TDP 57 W</li> <li>› Memory size: v = G: 32 GB DDR4 with ECC v = H: 64 GB DDR4 with ECC</li> <li>› 2LM Covers: w =0: no VITA48 2LM covers w =1: VITA48 2LM covers equipped</li> <li>› I/O feature option: x =0: Module profile is MOD3-PAY-1F1F2U1TU1T1U1T-16.2.15-4 x =1: Module profile is MOD3-PAY-1F1F2U1TU1T1U1T-16.2.15-2 y =N: No Front I/O connectors y =F: Front panel connectors with one serial line, one USB2.0 port and one RJ45 1000Base-T Ethernet.</li> <li>› SSD option: z = P : no SSD z = Q : 320GB NVMe SSD with preloaded Linux</li> </ul>

## Ordering Information

Environmental Class	Article	Part Number	Description
RA	<b>VX307C-RAuv-wxy00V1z</b> VX307C-RA11H-00F00V1P VX307C-RA11H-00F00V1Q	1075-2517 1075-2518	3U single slot 5 HP (1.0") VPX CPU Blade with Intel® Xeon® D-1700/1800 processor series, <b>rugged air-cooled (-40°C to +70°C)</b> with conformal coating  <b>Available options:</b> <ul style="list-style-type: none"> <li>&gt; Processor type:               <ul style="list-style-type: none"> <li>u=08: 8-Core D1732, base frequency 2.0 GHz, TDP 52 W</li> <li>u=11: 10-Core D-1848TER, frequency 2.0 GHz, TDP 57 W</li> </ul> </li> <li>&gt; Memory size:               <ul style="list-style-type: none"> <li>v = G: 32 GB DDR4 with ECC</li> <li>v = H: 64 GB DDR4 with ECC</li> </ul> </li> <li>&gt; 2LM Covers:               <ul style="list-style-type: none"> <li>w = 0: no VITA48 2LM covers</li> <li>w = 1: VITA48 2LM covers equipped</li> </ul> </li> <li>&gt; I/O feature option:               <ul style="list-style-type: none"> <li>x = 0: Module profile is MOD3-PAY-1F1F2U1T1U1T-16.2.15-4</li> <li>x = 1: Module profile is MOD3-PAY-1F1F2U1T1U1T-16.2.15-2</li> <li>y = N: No Front I/O connectors</li> <li>y = F: Front panel connectors with one serial line, one USB2.0 port and one RJ45 1000Base-T Ethernet.</li> </ul> </li> <li>&gt; SSD option:               <ul style="list-style-type: none"> <li>z = P : no SSD</li> <li>z = Q : 320GB NVMe SSD with preloaded Linux</li> </ul> </li> </ul>

Please ask [sales.kfr@kontron.com](mailto:sales.kfr@kontron.com) for a specific configuration.

## Related Products

### RTM (Rear Transition Module)

The Kontron **PB-VX3-40G-602** is a 3U VPX Rear Transition Module compliant with the VPX Standard – VITA 46.10.

It provides rear I/O peripherals connectivity such as serial lines, USB2.0 and USB3.0, SATA, 1000Base-T Ethernet and mDP++ connectors.

This RTM is a tooling equipment for lab use only.

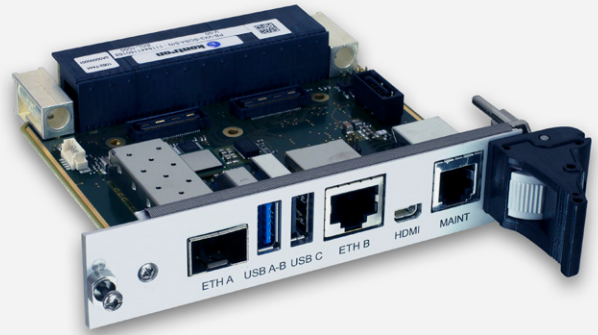

## Kontron Modular Computers S.A.S.

150 rue Marcellin Berthelot  
ZI de Toulon-Est - BP 244  
83078 Toulon Cedex 9  
France

Tel.: + 33 4 98 16 34 00  
sales.KFR@kontron.com  
www.kontron.com

More  
Information

