

Kontron VX33211

High-Performance 3U VPX GPU Board

Designed for advanced graphics, AI inference and GPGPU acceleration in rugged embedded platforms and embedded server applications

NVIDIA® RTX PRO™ 2000 Blackwell, Rugged Air & Conduction-cooled variants, designed in accordance with SOSA® Standard

3328
Cuda
Cores

104
Tensor
Cores

60
Watt
GPU TGP

8 GB
GGDDR7

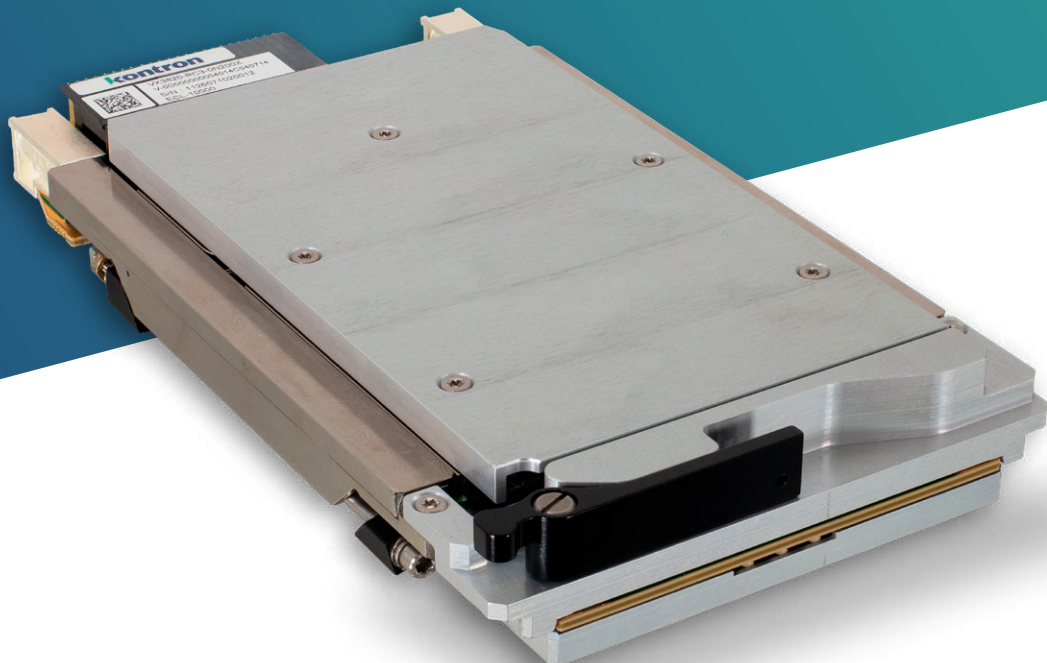

3U VPX High-Performance GPU Board

VX33211 3U VPX GPU Product Highlights

The VX33211 is a robust 3U VPX GPU board concept engineered for demanding environments and powered by the NVIDIA® RTX PRO™ 2000 Blackwell Embedded GPU. This advanced solution delivers up to 13.78 TFLOPS of FP32 computational performance, making it highly suitable for modern defense and rugged embedded platforms.

Key Features

- › Powered by NVIDIA® RTX PRO™ 2000 Blackwell Embedded GPU
- › Up to 13.78 TFLOPS FP32 performance for high-speed computing
- › 3328 CUDA cores for parallel processing tasks
- › 26 RT cores, enabling real-time ray tracing capabilities
- › 104 Tensor Cores for efficient AI inference and deep learning
- › 8 GB GDDR7 memory with a bandwidth of 384 GB/s for fast data throughput

Designed specifically for rugged defense platforms, the VX33211 supports a wide array of high-performance tasks, including advanced graphics processing, artificial intelligence inference, sensor data processing, and general-purpose GPU (GPGPU) acceleration.

The SOSA® Architecture Booster

The VX33211 design is available with the following VITA65 OpenVPX I/O intensive profiles:

- › **Slot Profile:** SLT3-PAY-1F1U1S1S1U1U2F1H-14.6.11-0
- › **Module Profile:** MOD3p-PAY-1F1U1S1S1U1U2F1H-16.6.11-4

Being developed in compliance with SOSA®-aligned OpenVPX profiles, the module benefits from profile interoperability and open-system integration practices, reducing both development risk and platform lifecycle costs for integrators.

Reliability and Robustness

Cooling Options

The air-cooled version of the VX33211 is designed for laboratory environments. If the intended application requires forced-air cooling, this variant can be qualified upon request to meet the necessary environmental demands.

In contrast, the conduction-cooled version is engineered specifically for rugged, mission-critical applications, making use of VITA 48-style plug-in unit mechanics. This design ensures reliable performance in highly constrained and challenging environments.

Extended Temperature Range

The VX33211 product family can operate reliably across a wide temperature range, from -40° to +85°C at the card edge, depending on the configuration and thermal design. This robust temperature tolerance ensures reliable operation across diverse and demanding deployment environments.

Typical Applications

ISR / Electro-Optical/Infra-Red Processing

Real-time image enhancement, target detection, and AI-driven sensor data analysis.

Mission Computing

GPU offload speeds up route planning, battlespace visualization, and map rendering.

Radar / Sonar / Electronic Warfare

Parallel processing used for beamforming, filtering, classification, and edge inference workflows.

Training & Simulation

Embedded 3D visualization and synthetic environment generation for rugged deployed systems.

3U VPX High-Performance GPU Board

Block Diagram

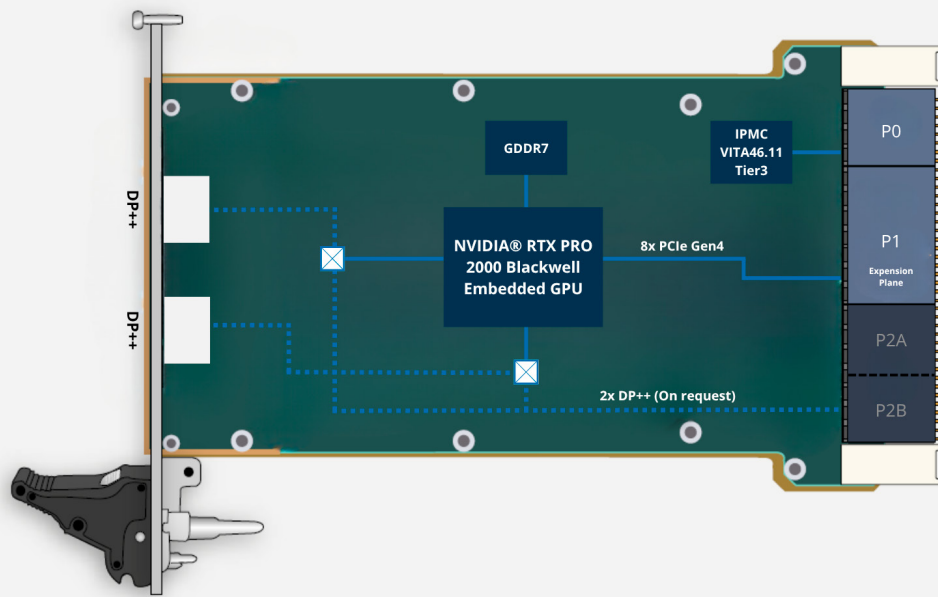

3U VPX High-Performance GPU Board

Technical Information

Form Factor		3U VPX
Processor	GPU	NVIDIA RTX PRO 2000 Blackwell Embedded
	CUDA / Tensor / RT Cores	3328 / 104 / 26
	FP32 performance	Up to 13.78 TFLOPS
	Core clock	Base 1522 MHz / Boost 2070 MHz
Memory	System Memory	8 GB GDDR7 24 Gbps / 128-bit / 384 GB/s
On-Board Features	Board Management System	IPMI controller for VITA46.11 Tier3 support and out-of-band system management.
	Sensors	Voltage, temperature and current sensors
Front Panel	IOS	2x mDP++ 1.4 (Air Cooled build option)
Backplane	IOS	PCI Express 4.0 x8; Optional 2 x DisplayPort 1.4
	Expansion Plane	x4 PCIe up to Gen4
Standard Profile	Slot Profile	SLT3-PAY-1F1U1S1S1U1U2F1H-14.6.11-0
	Module Profile	MOD3p-PAY-1F1U1S1S1U1U2F1H-16.6.11-4
Software	BSP	Linux BSP, Windows on request
	Graphics APIs	DirectX 12 Ultimate, OpenGL 4.6, Vulkan 1.2
Power	GPU Power	60 W TGP
Compliance		CE; REACH/ROHS

3U VPX High-Performance GPU Board

Environmental Specification

	SA - Air Cooled Version	RC - Rugged Conduction Cooled Version
Conformal Coating	No	Standard
Airflow	The air-cooled version of the VX33211 is designed for evaluation and testing in a laboratory environment. Qualification of this variant can be performed upon request.	na.
Cooling Method		Conduction
Operating Temperature		-40°C to +85°C
Storage Temperature		-50°C to +100°C
Vibration Sine (Operating)		20-2000 Hz - 5g
Random		5-100 Hz : PSD = +3dB/octave 100-1000 Hz : PSD = 0.1g ² /Hz 1000-2000 Hz : PSD = -6dB.octave
Shock (Operating)		40g/11 ms Half Sine
Altitude (Operating)		-1,500 to 60,000 ft
Relative Humidity		95% without condensation

Ordering Information

Environmental Class	Article	Part Number	Description
RC	VX33211-RC4-0N100	1080-7179	3U Single slot 5HP (1") VPX GPU - NVIDIA® RTX PRO™ 2000 Blackwell Embedded GPU - Conduction-Cooled 'RC4' (-40°C to +85°C) conformal coating - No Front Panel connectors - SLT3-PAY-1F1U1S1S1U1U2F1H-14.6.11-0 Slot Profile and MOD3p-PAY-1F1U1S1S1U1U2F1H-16.6.11-4 Module ProfileL - IPMI Controller for board health status
SA	VX33211-SA-0F100	1080-7180	3U Single slot 5HP (1") VPX GPU - NVIDIA® RTX PRO™ 2000 Blackwell Embedded GPU - Air-Cooled 'SA' (Laboratory Environment) - 2x mDP Connectors on the Front Panel - SLT3-PAY-1F1U1S1S1U1U2F1H-14.6.11-0 Slot Profile and MOD3p-PAY-1F1U1S1S1U1U2F1H-16.6.11-4 Module Profile - IPMI Controller for board health status

Please ask sales.KFR@kontron.com for a specific configuration.

3U VPX High-Performance GPU Board

Related Products

VX307H 3U VPX Plug-In Card

SOSA®-aligned Intel® 10nm x86 Microserver 3U VPX Blade

- › Intel® Xeon® D-2700 processors with 100G Integrated Ethernet
- › Up to 20 cores with AVX-512 vector engine
- › Security enforced by Hardware Root of Trust
- › VITA48 cooling builds with VITA 47 CC3 support
- › Designed in accordance with SOSA® requirements



More
Information

Kontron Modular Computers S.A.S.

150 rue Marcellin Berthelot
ZI de Toulon-Est - BP 244
83078 Toulon Cedex 9
France

Tel.: + 33 4 98 16 34 00
sales.KFR@kontron.com
www.kontron.com



More
Information