

» ALMA2f «

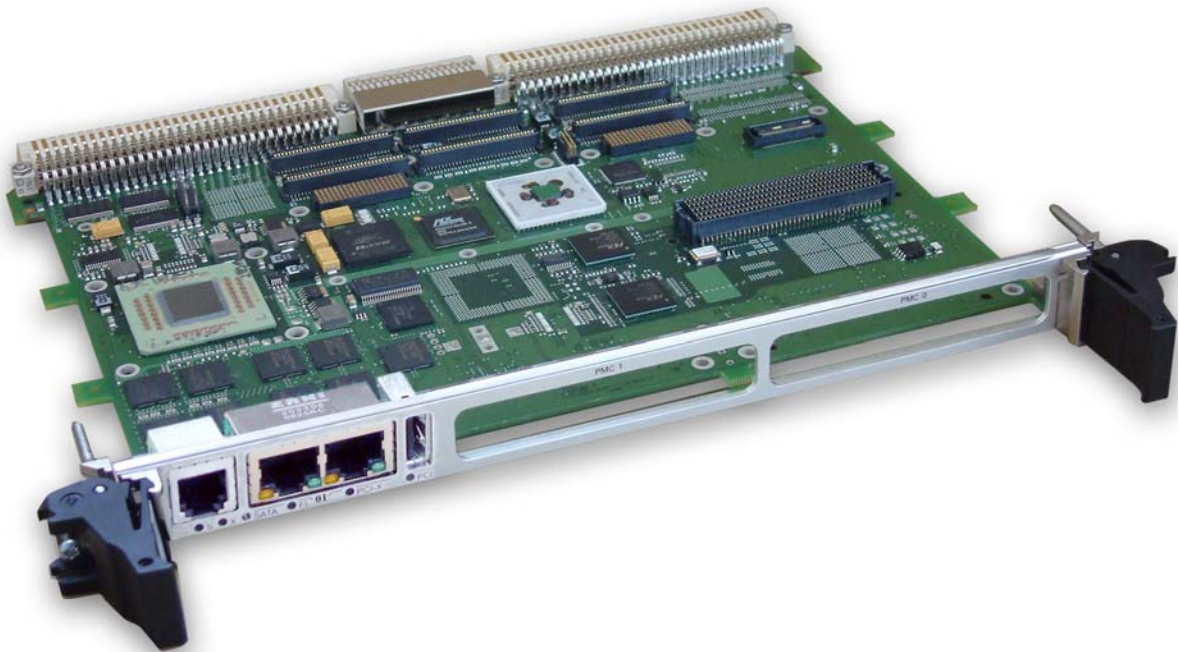

PCI32-66 MHz / VME 2eSST FPGA Bridge User Manual

CI.DT.A00-1e - October 2009



ALMA2f

PCI32-66MHz/VME 2eSST FPGA Bridge

User Manual
CI.DT.A00-1e

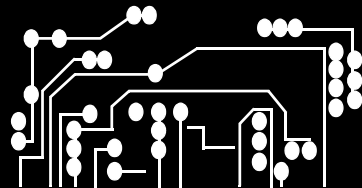

About This Book

The objective of this user's manual is to describe the functionality of the ALMA2f PCI32/VME 2esST Bridge for use by system designers and software developers.

Audience

This manual is intended for system software and hardware developers of VME products using the industry-standard PCI Local Bus as the on-board local bus.

It is assumed that the reader has a knowledge of the VMEbus Specification and of the PCI Local Bus Specification Revision.

References / Documentation

1. The VMEbus SPECIFICATION - conforms to ANSI/IEEE STD 1014-1987 - VITA
2. VME64 EXTENSIONS - ANSI/VITA 1.1 - 1997 - Oct 7,1998
3. VME 2eSST, VITA 1.5-200X/Draft 2.3 - Nov 6,2002
4. THE VMEbus SPECIFICATION - conforms to ANSI/IEEE STD 1014-1987 - VITA
5. THE VMEbus HANDBOOK - expanded third edition, Wade D. Paterson - VITA
6. PCI LOCAL BUS SPECIFICATION - Revision 2.2, December 18, 1998 - PCI SIG
7. PCI SYSTEM DESIGN GUIDE - Revision 1.0 8 September, 1993 - PCI SIG

Conventions

- "PCI Bus Specification" in the text refers to the "PCI Local Bus Specification, Revision 2.0"
- Active low signals are labelled with a "b" suffix, they are defined as true (asserted) when they are at logic low (0).
- Active high signals are labelled with no suffix, they are defined as true (asserted) when they are at logic high (1).
- Logic low on a signal corresponds to the low voltage, logic high to the high voltage.

Acronyms and Abbreviations

Msb:	Most significant bit(s)
BGA:	Ball Grid Array
2eSST:	two-edge Source-Synchronous Transfer
VMEbus:	VersaModule Eurocard bus
SBC:	Single Board computer
BLT:	Block Transfers
MBLT:	Multiplexed Block Transfers

Table of contents:

Chapter 1. Overview	5
1.1 ALMA2f GENERAL DESCRIPTION	5
1.2 Operating Specifications	5
1.3 Features	6
1.4 VMEbus signals external buffering example	8
1.5 FUNCTIONAL DESCRIPTION	9
1.5.1 VMEbus interface	9
1.5.2 PCI bus interface	11
1.6 DMA	13
1.7 Interrupt management	13
1.8 Special Features	14
1.9 Addressing through the ALMA2f bridge	15
1.9.1 VME to PCI access	15
1.9.2 PCI to VME access (1K-Entry Mapping Table)	16
1.10 Timings	18
1.10.1 Clock Timing	18
1.10.2 PCI IO Specifications	18
1.10.3 VME 2eSST Timings	19
1.11 REGISTERS	20
1.11.1 Registers Space Description	20
1.11.2 Access to internal ALMA2f Registers	21
1.11.3 ALMA2f Registers map	22
Chapter 2. ALMA2f REGISTERS	23
2.0.1 PCI Configuration Header Registers	24
2.0.2 PCI Operation Registers	37
2.0.3 ALMA2f Utility Registers	46
2.0.4 ALMA2f VME Registers	51
2.0.5 ALMA2f DMA Registers	63
2.0.6 ALMA2f Interrupt Operation Registers	73
2.0.7 ALMA2f Extended Registers	83
2.0.8 Control/Status CSR Registers	108
2.0.9 Configuration ROM (CR) Register	112
2.0.10 PCI IP Core Registers	118
Chapter 3. SIGNAL DESCRIPTIONS	121
3.1 VME bus interface signals	123
3.2 PCI bus interface signals	124
3.3 General purpose signals	125
3.4 JTAG signals	127
3.5 FPGA Configuration signals	127
Chapter 4. PACKAGING	129
Chapter 5. INITIALIZATION & RESET	133

5.1 Overview	133
5.2 Reset with POWER_ON_RESETb	136
5.3 Reset controlled by the RESETINb input	137
5.4 Reset controlled by the Addressed Reset operation	138
5.5 Reset controlled by the V_SYSRESETib input (VME SYSRESET*)	139
5.6 Reset controlled by the Reset Watchdog	140
5.7 Sampling hardware configurations	140
5.8 Sampling VME System Controller pin.	140
5.9 Suggested usage of RESETINb and RESETOUTb pins	140
5.10 VME SYSFAIL* Handling	141
5.11 Reset Watchdog	143
5.12 AUTO SLOT ID function	145
5.12.1 AUTO_SLOT_ID is at 1:	145
5.12.2 Normal AUTO_SLOT_ID operations:	145
5.12.3 input signal AUTO_SLOT_ID is at 0:	146
Chapter 6. INTERRUPTS	147
6.1 Interrupt Management overview	147
6.2 Generating Interrupt to the VME from the PCI_AVITb pin	148
6.2.1 «AVIT VME cycle».	148
6.2.2 VME Interrupt Request Cycle (IRQ7-1*)	148
6.3 Masking and Generating interrupts to the PCI	149
6.3.1 Routing to Interrupt Pin:	151
6.3.2 Routing to INT1b,2b,3b pins with CSR_USER_DEF_INT_MSKOUT	152
6.4 Interrupt sources translated to an interrupt to PCI	153
6.4.1 VME interrupts.	153
6.4.2 Addressed Interrupts	153
6.4.3 ALMA2f exceptions, end of DMA or timeout Interrupts	154
6.5 VMEbus Interrupter.	155
6.5.1 ALMA2f VME interrupt generation through Register:	155
6.6 ALMA2f response to a VME interrupt acknowledge cycle	156
Chapter 7. ERROR HANDLING	157
Chapter 8. DMA Controller Operations	159
8.1 Overview.	159
8.2 DMA Channels programming	159
8.3 DMA Operation Timing	166
Chapter 9. ENDIAN CONVERSIONS	169
9.1 VME data Big Endian conversion to Little Endian	169
9.2 PCI data Little Endian conversion to Big Endian	171

Chapter 1. Overview

1.1 ALMA2f GENERAL DESCRIPTION

ALMA2f provide an highly integrated single chip solution to interface a VME64 bus with 2eSST protocol (two-edge Source-Synchronous Transfer) and a **32-bit 66 MHz PCI Bus**.

All the bridge features are fully programmable from PCI bus or VME bus.

This component allows VMEbus single board computer and I/O board vendors to develop solutions with PCI support, taking, thus, advantage of the growing family of PCI components in the market.

For VME backplanes applications with 2eSST protocol, the SN74VMEH22501 universal bus transceivers is recommended.

ALMA2f is almost software compatible with the previous PCI to VME bridge called ALMA2e at the exceptions described in the document **FT.SF.193 - ALMA2f Functional Specification**.

The packaging and power supplies are different and so **ALMA2f FPGA is not pin to pin compatible with ALMA2 ASIC**.

A major difference is that ALMA2e has a PCI32-66 MHz interface (ALMA2E is PCI64-66MHz)

1.2 Operating Specifications

Table 1-1.

ALMA2f PCI to VME Bridge Specifications	
Technology	Cyclone [®] III family of 65-nm ALTERA FPGAs
Temperature Range	-40 to 100 °C Junction
Performance Estimate	up to 70 M Bytes/sec on the VME64x up to 256 M Bytes/sec on VME with 2eSST protocol (340 MByte/sec peak) up to 264 M Bytes/sec on the PCI 32 @ 66MHz
Signal I/Os	252 I/Os (not 5V tolerant)
Power Supply	1.2 V +/- 0.05 V for Core 2.5 V +/- 5% for Analog PLL 3.0 V +/- 0.15 V for PCI I/Os (not 5V tolerant) 3.3 V +/- 5% for I/Os

Table 1-1.

ALMA2f PCI to VME Bridge Specifications	
Power Dissipation (est.)	0.9 W Worst case @ 66 Mhz Estimated
Packaging	19x19mm, 324-Pin FineLine Ball-Grid ArrayCeramic , 1.00 mm pitch, Pb-free

1.3 Features

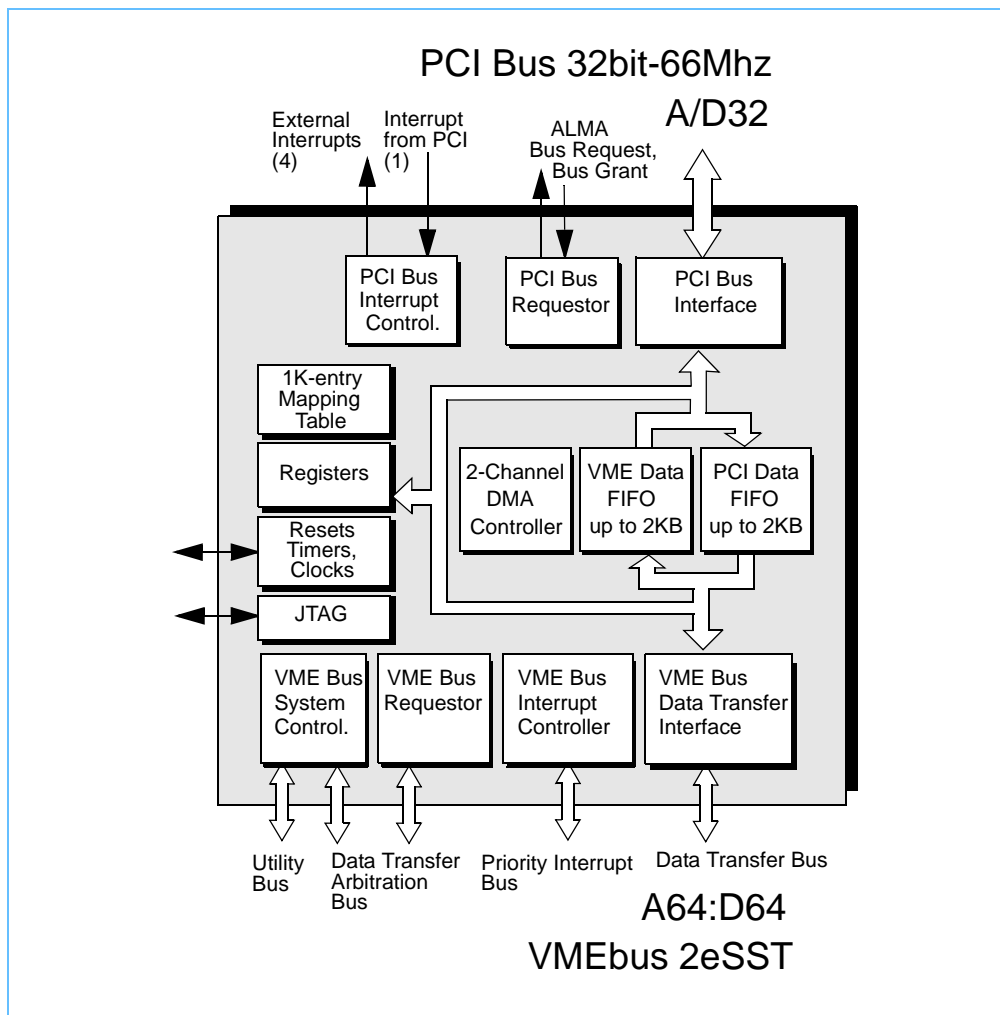

Figure 1 : ALMA2f block diagram

High performance Bridge between PCI and VME

- Asynchronous transfers between PCI and VME
- Deep decoupling Transmit and Receive FIFOs
- VME64 compliant, up to 70 MBytes/sec
- External VME buffers, TTL and ETL buffers supported
- Register set fully accessible from both the PCI bus and the VMEbus ports
- Two-channel programmable DMA Controller

VMEbus interface

- VME64 and IEEE-std-1014-1987 compliant
- VMEbus System Controller
- Autoslot ID mechanism
- VMEbus Requestor (Level 0-3)
- VMEbus Interrupter and Interrupt handler (IRQ1-7)
- VMEbus master/slave A32, A24, A16:D32, D16, D8, UAT
- VMEbus master/slave A32, A24:D32BLT, D64MBLT
- VMEbus master/slave A64, D32, D32BLT, D64MBLT
- VMEbus master/slave 2eSST: A64, A32
- VMEbus master/slave 2eSST Broadcast: A64, A32
- Programmable VME slave image base address and size (16 VME slave channels) and VME to PCI access conversion (address translation, bus cycles parameters).
- Programmable Posted Write, Prefetch Read, coupled mode
- BLT/MBLT cycle
- Semaphore registers

PCI 32-bit 66MHz bus interface

- Fully compliant, 32-bit, 33 to 66 MHz PCI bus interface Revision 2.2
- PCI master/slave with burst operation
- 1K-entry on-chip Mapping Table for PCI to VME access conversion (address translation, bus cycle parameters)
- Little Endian / Big Endian byte ordering conversion with programmable conversion modes
- Programmable Posted Write, Prefetch Read, Coupled Mode

Clocking

- PCI clock : 33 to 66 MHz
- VME Clock : 100 MHz

1.4 VMEbus signals external buffering example

The following figure shows how external signal buffering can be done with 22501 or equivalent technologies.

ALMA2f control signals **xxxDIR** are used to set the direction of the corresponding signals. For the Open collector type of drivers, it is possible to choose between inverting and non inverting signal by placing a 1 or a 0 on the **OC_CTL** input pin of ALMA2f.

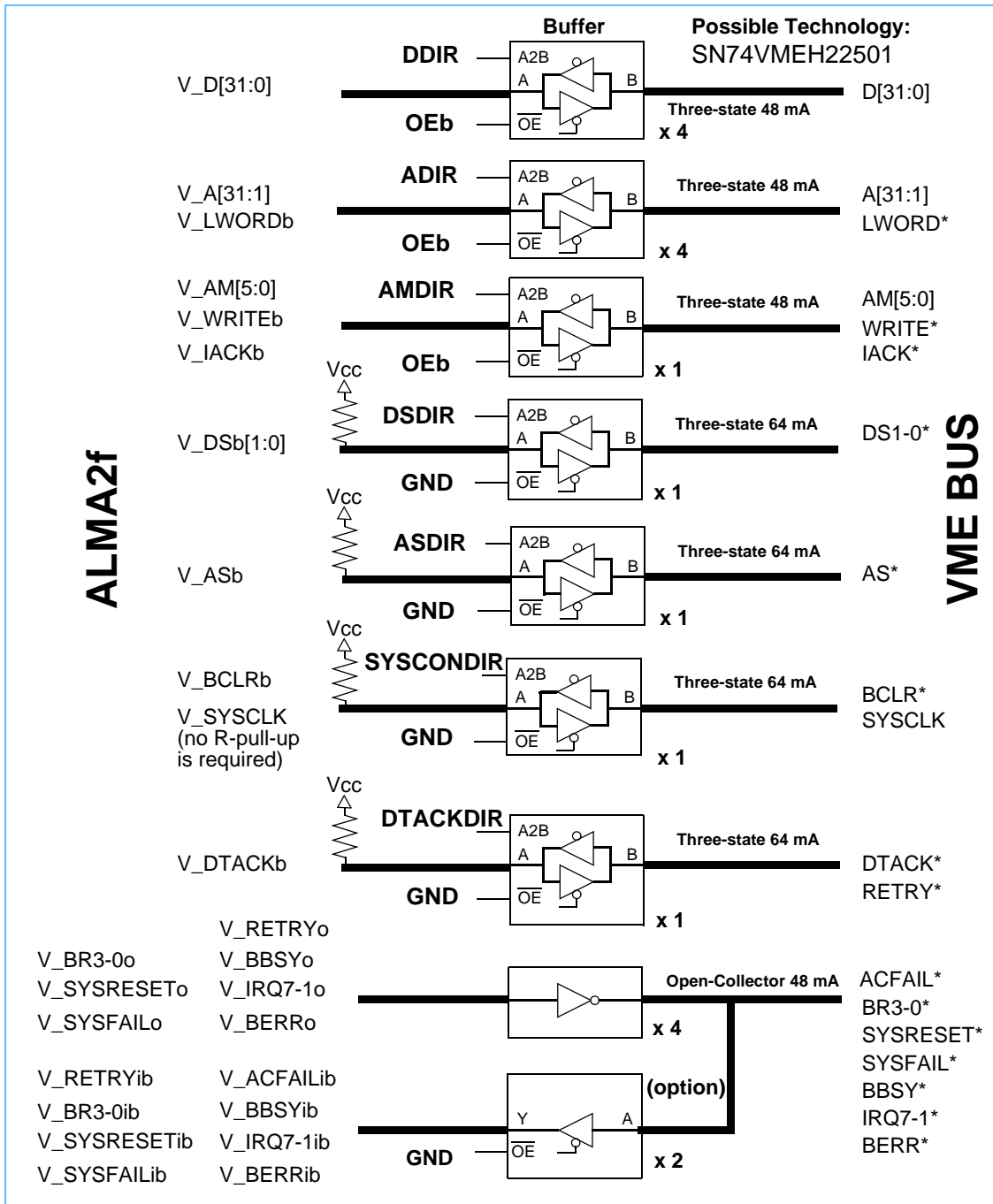

Figure 2 : VME buffering of ALMA2f signals

1.5 FUNCTIONAL DESCRIPTION

The ALMA2f VME/PCI bridge is an highly flexible component that supports Master and Slave bus operations on both the PCI bus and VMEbus ports.

1.5.1 VMEbus interface

- **VME Master interface**

The ALMA2f VME master module provides D32, D16, D8 and UAT under A32, A24 and A16 addressing modes plus D64 BLT and D32BLT under A64, A32 and A24 addressing modes. Any Address Modifier (AM) is supported.

The VME block mode, D64 or D32, can be automatically started from a PCI burst. The use of internal FIFOs allows maximum speed in decoupled mode (Read-ahead or Write-posting).

A set of registers allows users to set the new FIFO behavior with a high flexibility according to different VME applications.

As a VME master in DMA mode ALMA2f provides A64, A32, broadcast A32 and broadcast A64 2eSST transaction. ALMA2f allows five different speed for 2eSST transfer. Data reception can be done at the theoretical maximum speed of 320 Mb/sec.

- **VME Slave interface**

The ALMA2f VME slave interface supports the same addressing mode and data size as the VME master interface.

Sixteen decoding channels are available for accessing the PCI bus from the VME bus. Each channel can be configured independently in the A64, A32, A24, A16 address space.

Height out of 16 channels can be configured independently in the A64 2eSST, A32 2eSST, A64 2eSST broadcast or A32 2eSST broadcast address space.

These channels allow the user to program the PCI bus access parameters with a minimum granularity of 1 Mbyte.

A set of registers allows users to set the new FIFO behavior with a high flexibility according to different VME applications.

As Slave ALMA2f provides A64, A32, broadcast A32 and broadcast A64 2eSST transaction. ALMA2f allows five different speed for 2eSST transfer. Data reception can be done at the theoretical maximum speed of 320 Mb/sec.

VME RMW cycle is supported by ALMA2f, however the targeted PCI resource is not locked during the read and write (ALMA2f does not support the PCI LOCK mechanism).

Each channel can be configured with selectable parameters. An additional channel available under A16 or A24 CR/CSR space is provided for ALMA2f internal registers access.

ALMA2f provides an A24 CR/CSR space as define in the VME64x specification.

- **VME bus requester**

ALMA2f drives the bus requests on the 4 levels, BR0 to BR3 (optional FAIR policy), and the release of the bus can be managed with ROR (Release On Request), RWD (Release When Done), ROC (Release On Clear) or RNE (Release NEver) policy.

- **VME System controller**

ALMA2f is VME bus system controller if the input pin VME_SYSCONT_INb is strapped to Ground.

ALMA2f supports the «auto system controller» mechanism as defined into the VME64 norm, if this pin is connected to the VME BG3IN* signal and if the backplane interface logic on board connects a 3-Kohm resistor between BG3IN* and the ground.

ALMA2f includes a mechanism for VME64x AUTO SLOT ID operation.

The following modules are activated if ALMA2f is selected as the VME system controller:

- VME arbiter with two arbitration capabilities: PRI (fixed priority), RRS (Round Robin) depending on the user choice. A fixed arbitration time-out of 8ms is selectable between BGOUT* transmission and BBSY* reception.
- DTB Timer. A programmable timer (4 us to 256 us) measures the elapsed time between the DS* assertion and the DTACK* or BERR* signal.
- SYSCLOCK generator at 16 MHz.
- SYSRESET* can be generated (See Special Features).
- SYSFAIL* generator, from specific pin SYSFAILINb or from a special ALMA2f register access.

Operation in 2eSST mode

ALMA2f supports 2eSST transfers as defined in the Vita 1.5 standard. As a VME slave, up to 8 addressing windows can be programmed to accept 2eSST transfers. ALMA2f will initiate 2eSST transfers over the VME by a dedicated setting of the internal DMA controller.

No 2eSST transfers will be generate over the VME as a result of a PCI slave operation. Only the 6U version of the standard is implemented. The slower 2eVME protocol is not supported.

During address phase 1 (the first DS0* assertion), an address modifier encoding of 0x20 is used for 2eSST transfers. The extended AM codes used by ALMA2f as a VME master or slave are shown in table 1 below:

Table 1-2. Extended AM for 2eSST used by ALMA2f

Extended Address Modifier codes	Address/Data Mode
0x11	A32/D64 2eSST
0x12	A64/D64 2eSST
0x21	A32/D64, Broadcast 2eSST
0x22	A64/D64, Broadcast 2eSST

Address phase 2 (DS0* de-assertion) includes the cycle count and the speed rate. For the cycle count, ALMA2f uses either the block size programmed in the DMA controller (divided by two because of the 2 edges) or a smaller value to avoid crossing a 2 KB boundary or to avoid transferring more data than requested at the end of the DMA.

As a 2eSST data receiver, ALMA2f can accept all the possible rates: SST160, SST267, SST320. However, depending on particular system timing performance behavior, it is possible not to accept transfers at SST320 rate by clearing bit 3 of VME2ESST_CTL register; a slave error would then be generated during address phase 3 if a rate of SST320 was detected by ALMA2f as a slave.

As a 2eSST data source, ALMA2f generates one of the 3 possible rate codes (SST160, SST267, SST320) according to its DMA_CHN_RATE register setting. The actual timings of the 2eSST are based on the setting of register VME2ESST_CTL. It is the user responsibility to program actual 2eSST timings compatible with the 2eSST rate code selected: actual timings should correspond to a rate less than or equal to the rate code, with set-up and hold times greater than or equal to the 2eSST requirements.

During address phase 3 (DS0* reassertion), if a broadcast 2eSST operation has been selected (XAM 0x21 or 0x22), VME addresses A21 to A1 indicate the geographical address of the slaves to be targeted by the broadcast. To select a slave with a geographical address *i*, bit *A_i* should be set to 1. For each DMA channel, the slaves participating in the broadcast operation are programmed in register DMA_VME_SLVSEL.

During the broadcast operation, the master responds with DTACK* to its own cycles, and the participating slaves capture the transmitted data. If a slave is not ready to accept the full broadcast operation, it asserts RETRY* during address phase 3 to request for the transfer to be restarted.

1.5.2 PCI bus interface

• PCI Bus command

ALMA2f initiates and responds to a subset of PCI bus commands. PCI bus command is defined by the P_CBELb[3:0] signals during the address phase of a transaction. The Table 1 defines the PCI bus command subset that the ALMA2f supports as a slave and as a master.

Table 1-3. PCI Commands supported by ALMA2f

P_CBELb[3:0]	Command Type	Supported as Slave	Supported as Master
0000	Interrupt acknowledge	No	Yes
0001	Special Cycle	No	Yes
0010	IO read	Yes	Yes
0011	IO write	Yes	Yes
0100	Reserved	No	No
0101	Reserved	No	No
0110	Memory Read	Yes	Yes
0111	Memory Write	Yes	Yes
1000	Reserved	No	No
1001	Reserved	No	No
1010	Configuration Read	Type 0 : Yes Type 1 : No	No
1011	Configuration Write	Type 0 : Yes Type 1 : No	No

Table 1-3. PCI Commands supported by ALMA2f

P_CBELb[3:0]	Command Type	Supported as Slave	Supported as Master
1100	Memory Read multiple	Yes: Aliased to Memory Read	No
1101	Dual Address cycle	No	No
1110	Memory Read Line	Yes: Aliased to Memory Read	Yes
1111	Memory Write & Invalidate	Yes: Aliased to Memory Write	Yes

• PCI Master Interface

Interrupt Acknowledge or Special Cycle can be initiated from the VME through a read or write access to a specific ALMA2f internal register..

ALMA2f can generate PCI burst up to 2KB without wait state.

• PCI Slave interface

The ALMA2f PCI slave interface decodes I/O cycles, MEMORY cycles and Type 0 CONFIGURATION cycles.

Note that MEMORY READ MULTIPLE, MEMORY READ LINE and MEMORY WRITE & INVALIDATE are also accepted by ALMA2f but are treated as regular MEMORY READ or MEMORY WRITE accesses.

ALMA2f slave image base addresses and address spaces are encoded into 6 PCI Base Address Registers defined into its Configuration Header space.

Five Base Address registers (BAR) are available for decoding of PCI accesses to the VME and one Base Address register is reserved for decoding of PCI ~~I/O~~ **Memory** accesses to ALMA2f Space Registers.

PCI to VME address translation through 1K Mapping table

In addition a Mapping table of 1K entries is used to enable/disable PCI MEMORY space accesses (up to 4GB) as well as PCI I/O space accesses (up to 4GB), with a granularity of 8MB. For a given 8MB addresses block, ALMA2f selects the associated Mapping Table entry in which are programmed: the VAL bit to enable/disable the PCI access, the WP bit to enable/disable PCI Write Posting, plus all the parameters required to generate a master access onto the VMEbus, such as: address bits for PCI to VME address translation (ADD, 9 bits), the VME Address Modifiers (AM, 6 bits), Little/Big Endian conversion mode (LEBE coded on 2bits), and Read-Ahead enable (RA, 1bit).

To accommodate software mapping flexibility requirements, ALMA2f allows for some programming of its slave image characteristics via a selectable feature. So, the so-called hard-coded recognition address range depth and space (as defined by the base address field size and the I/O space/MEMORY space indicator bit value within the PCI Base Address Register layout) can be selectively overridden by programmed values.

As slave ALMA2f can receive PCI burst up to 2KB without wait states during data phase.

1.6 DMA

ALMA2f has two DMA channels, user accessible, with a programmable priority between channels, and the option that blocks from the two channels may be interleaved.

Each channel is initialized with a source address, a destination address, a transfer count up to 16 MBytes (2M words of 64 bits maximum), a block count up to 2KBytes (up to 256 words of 64 bits), plus all the necessary control data (VME Address Modifiers, PCI bus command, transfer direction, etc.).

When DMA ends, the information related to the completion of the DMA (normal ending or a description of the errors) is available in an interrupt status register and an error status register. DMA completion can be signalled via an interrupt to the PCI bus.

The DMA engine supports all of the 2eSST operations (A64, A32, A64 broadcast and A32 broadcast transaction). ALMA2f allows five different speed for 2eSST transfer. Data reception can be done at the theoretical maximum speed of 320 Mb/sec.

Table 1-4. DMA performance

Transaction Type	Performance MB/sec
DMA PCI to VME Single	8
DMA PCI to VME BLT D32	34
DMA PCI to VME MBLT D64	70
DMA PCI to VME 2eSST mode	240
DMA VME to PCI Single	7
DMA VME to PCI BLT D32	22
DMA VME to PCI MBLT D64	50
DMA VME to PCI 2eSST mode	230

1.7 Interrupt management

The ALMA2f interrupt controller can handle different interrupt sources:

- 7 VME interrupts (IRQ7*-IRQ1*).
- 8 addressed interrupts (occur when a specific 8-bit register is addressed in write mode from the PCI or the VME).
- ACFAIL* and SYSFAIL* on VMEbus.
- Internal Exceptions (End of DMA, error acknowledges on PCI bus or VMEbus, VMEbus arbitration time-out...).

All these interrupts can be masked and can drive either the PCI bus interrupt pin (P_INTAb) or 3 additional programmable interrupt pins: P_INT1b, P_INT2b or P_INT3b.

ALMA2f can also generate VME Interrupts (IRQ7*-IRQ1*) when a specific 8-bit register is addressed in write mode from the VMEbus or the PCI bus. The release mechanism of this interrupter is ROAK (Release on Acknowledge).

An external interrupt input pin (PCI_AVITb) allows also to generate either VME interrupts (IRQ7*-IRQ1*) or a VME bus cycle whose characteristics are fully programmable (read or write cycle, value of address, address modifiers and data).

1.8 Special Features

• Reset controller

ALMA2f handles the following Reset sources:

- Power-on-reset when input pin POWER_ON_RESETb is asserted Low.
- VME reset (SYSRESET*) when input pin V_SYSRESETib is asserted Low.
- Local reset when input pin RESETINb is asserted Low.
- Addressed Reset when a specific 8-bit register is addressed in write mode.
- Reset due to Reset Watchdog function.

These resets can be propagated to the locations below according to programming:

- ALMA2f internal reset
- VME reset (SYSRESET*): assertion of the V_SYSRESETo pin High.
- Local reset: assertion of the RESETOUTb pin Low.

• Data conversion

Little Endian and Big Endian byte ordering conventions are fully supported by ALMA2f. Little Endian/Big Endian conversions are automatically performed on both data directions, according to a programmable conversion mode as defined below (refer to the LEBE field of the VME slave channels and of the PCI Mapping Table entry):

- LEBE=00: "No conversion" (Data byte ordering and Address 2 low-order bits remain unchanged)
- LEBE=01: "Address Coherency"
(Data bytes are swapped, Address 2 low-order bits remain unchanged)
- LEBE=10: "Data Coherency"
(Data byte ordering remain unchanged, Address 2 low-order bits are modified)
- LEBE=11: "Bytes Translation with No Swapping"
(Data bytes are translated, Address 2 low-order bits remain unchanged)

• Hardware semaphores

VME Multiprocessor architectures often need to be able to share common resources between different VME cards. The ability for a card to have hardware mechanisms for handling semaphores is therefore necessary.

The standard VME rev C Read-Modify-Write cycle is able to support semaphores. Unfortunately, there are a few drawbacks in using this RMW VME protocol:

- VME rev C RMW is a slow mechanism and its support can even slow down non RMW standard cycles. This is due to the signalling method on the VME: indeed, indivisible cycles can only be recognized at the end of the read phase.
- RMW cycles are often not used nor generated by modern microprocessor architectures, and hardware emulation of such cycles is not easy to design.

For these reasons, the ALMA2f chip includes 4 shared 8-bit Semaphore registers so that the design of VME multiprocessor architectures can be greatly simplified.

- **VMEbus DeadLock avoidance Feature:**

BRLOCb & BGLOCb pins / VME_REQ_LBR & VME_REQ_LBG bits

In order to prevent deadlock situations, ALMA2f is providing a mechanism allowing a PCI bus master device to obtain the VMEbus ownership before it starts its access to ALMA2f. By doing so, the device is guaranteed that ALMA2f will not retry its transaction. This feature can be advantageously used by those PCI bus master devices which are not supporting the PCI Retry protocol and which therefore may be responsible of deadlocks.

The mechanism has two implementations, one is under pin control (BRLOCb as bus request pin, BGLOCb as bus grant pin) the other is under software control through the "VME Request control register" at the address @70. The bit VME_REQ_LBR of this register is used for bus request, and the bit VME_REQ_LBG for bus grant.

Once granted the PCI master device issues transaction to access VME resources as long as it wishes, and must hold the BRLOCb pin active during all the time it is operating. However, ALMA2f may at any time ask the device to release the VMEbus by de-asserting BGLOCb or resetting the VME_REQ_LBG bit (this event may also be signalled via an interrupt). In this case the device must stop its current transaction as soon as it can and signal that it has finished its operation by de-asserting the BRLOCb pin or by resetting the VME_REQ_LBR bit.

1.9 Addressing through the ALMA2f bridge

High Addressing flexibility is a key feature to enable a bridge such as ALMA2f to accommodate a whole range of uses, from a simple SBC (Single Board Computer) VME card to a complex VME multiprocessor architecture: in the majority of VME computer designs, software compatibility (at user and kernel level) with existing standard desktop workstations or PCs is a major issue and ALMA2f addressing flexibility allows the VME computer to use the same address mapping convention as the one defined by the chosen microprocessor architecture.

1.9.1 VME to PCI access

As a VME Slave, ALMA2f decodes if its VME slave image address and address modifiers are the target of the VME access, through use of 16 decoding channels whose address recognition range depth is programmable (1MB to 4GB Min/Max depth). These features accommodate well with the big parcelling out of the VME address map sometimes found in VME systems.

To permit the mixing of VME64 and 2eSST, 8 out of 16 Channels can be programmed as 2eSST.

ALMA2f responds to the VME access under the following conditions:

- VME address 12 Msb match the address field of at least one channel.
- VME address modifiers match the address modifiers field of the channel that has been hit.
- The channel that has been hit is enabled.

A prioritization is performed between channels when more than one is hit. The PCI address is obtained through a translation of the VME address with a granularity of 64KB. Thus, the offset field of the selected channel is added to the 16 Msb of the VME address. While the PCI bus command is obtained from the PCI bus command field of the selected channel

These capabilities allows for high mapping flexibility of VME addresses into the 4GB PCI address MEMORY and I/O spaces.

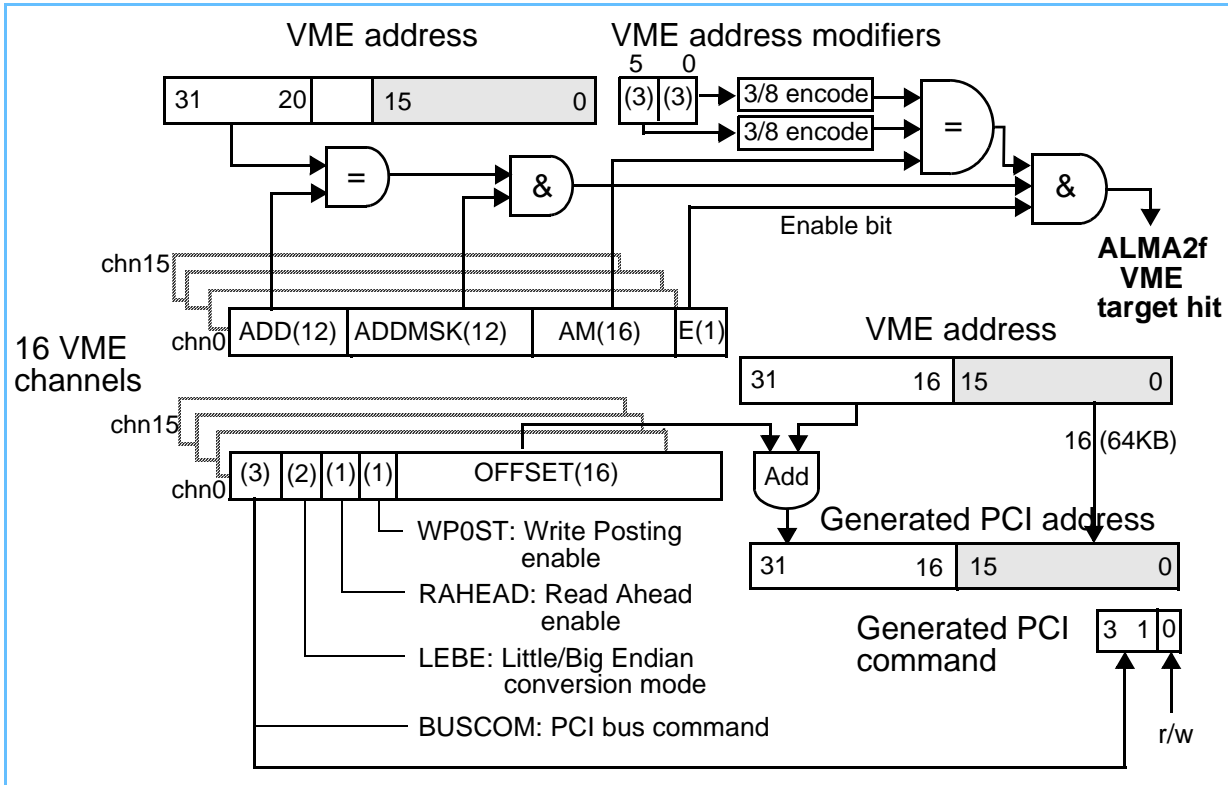

Figure 3 : VME slave decode & address translation mechanisms for a VME access to PCI.

1.9.2 PCI to VME access (1K-Entry Mapping Table)

ALMA2f as a PCI slave implements 6 Base Address Registers for PCI bus address and command decode.

At Reset these registers are initialized such as to define five ranges of 256 MB mapped in the MEMORY space (3 ranges) and in the I/O space (2 ranges) while one range of 256B mapped in the I/O space has been reserved for decoding of those PCI I/O cycle accessing internal registers.

After reset, the five 256MB windows can be changed to any size from 16MB up to 2GB and to any space (I/O or MEMORY) thru registers programming. Besides the regular decode through Base Address Registers, an additional validation of the PCI access is performed with a granularity of 8MB in the MEMORY or I/O space. For that purpose ALMA2f implements a 1K-entry programmable Mapping Table, whose low-order 512-entries are used to validate MEMORY accesses while the high-order 512-entries are used to validate I/O accesses (through a validation bit, VAL, programmed in the entry line). PCI address 9Msb are used to index one or the other of these blocks, according as PCI cycle is MEMORY or I/O.

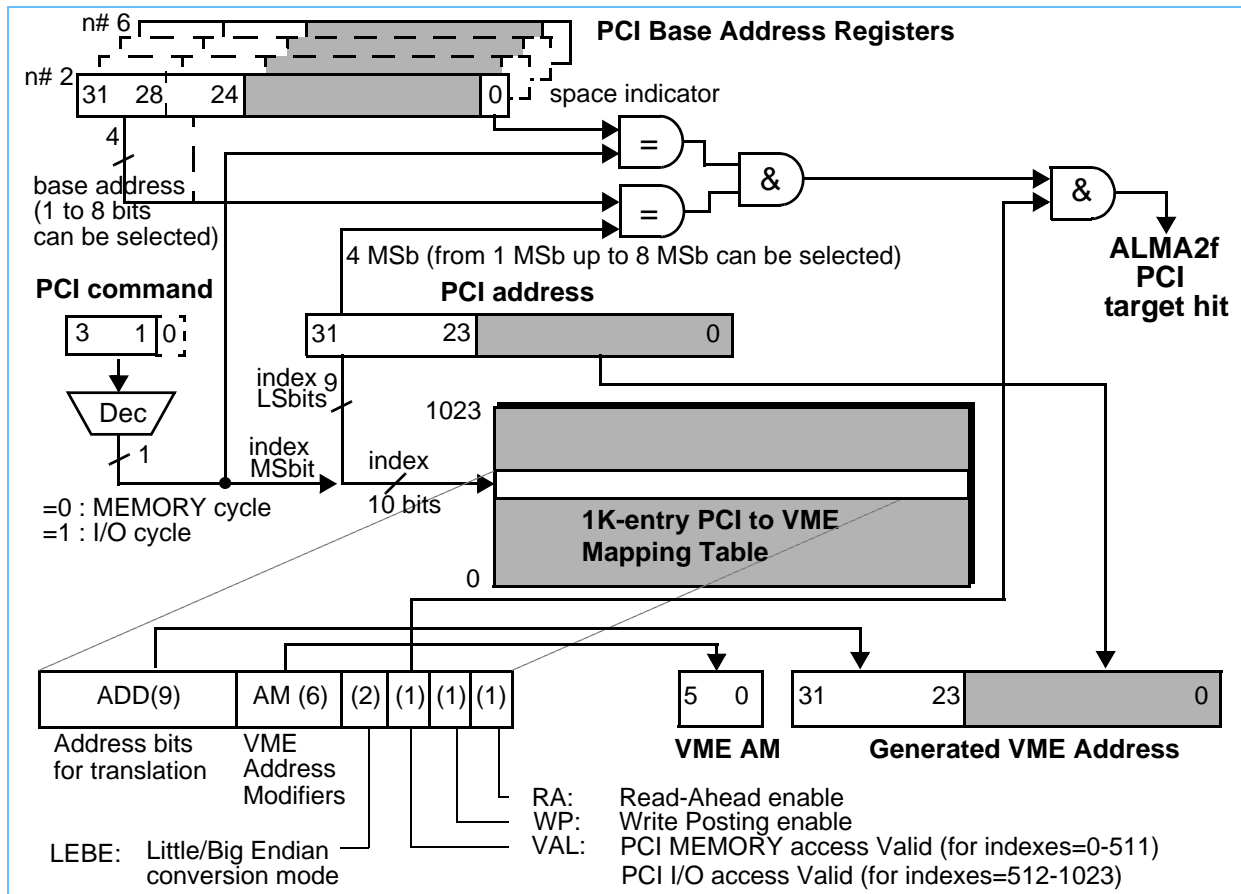

Thus, ALMA2f selects itself as the target of the PCI access when both Base Address Registers and Mapping Table are hit.

The selected Mapping Table entry tells the ALMA2f PCI slave behavior on writes (write posting enable/disable) and provides all the informations useful to cycle generation onto the VMEbus, such as address translation, address modifiers, Little Endian/Big Endian conversion mode and read prefetch enable/disable

The Mapping Table can be disabled through programming. In that mode, called «transparent mode», an ALMA2f register content and some hard-coded informations substitutes themselves to the Mapping Table programming.

The register provides two informations:

- The first indicates whether PCI access can be accepted or rejected (no distinction is made between MEMORY or I/O space accesses and the 8MB granularity does not apply anymore),
- The second provides address modifiers value of the VME cycle to generate.

All others informations are hard-coded as follows:

no address translation (PCI address is forwarded as is onto the VMEbus), Little Endian/Big Endian conversion mode set to the Address Coherency mode, read prefetching and write posting set to disabled.

1.10 Timings

1.10.1 Clock Timing

Table 1-5. Clock timing

Parameter	Min	Typical	Max	Units
VME_CLK input frequency	-	100	-	MHz
VME_CLK duty cycle	40		60	%
P_CLK	33		66	Mhz
P_CLK duty cycle	40		60	%

1.10.2 PCI IO Specifications

Following timing are given for ALMA2f as input or output on a PCI bus at 66 MHz, loaded by 10 pF.

Worst Case conditions: **100 degrees** junction temperature and voltage **-0%**

Best Case conditions : **-40 degrees** junction temperature and voltage **+0%**

Table 1-6. PCI timing

PCI Signal	Input				Output			
	Setup min required		Hold min required		tpd min		tpd max	
	PCI66 Bus	Alma2f	PCI66 Bus	Alma2f	PCI66 Bus	Alma2f	PCI66 Bus	Alma2f
P_AD[31:0]	3 ns	2.56 ns	0 ns	- 0.48 ns	2 ns	2.91 ns	6 ns	5.86 ns
P_CBEb[3:0]	3 ns	2.57 ns	0 ns	- 0.40 ns	2 ns	2.75 ns	6 ns	5.32 ns
P_DEVSELb	3 ns	1.70 ns	0 ns	- 0.43 ns	2 ns	2.74 ns	6 ns	5.31 ns
P_FRAMEb	3 ns	2.09 ns	0 ns	- 0.10 ns	2 ns	2.75 ns	6 ns	5.32 ns
P_GNT	5 ns	2.64 ns	0 ns	- 0.25 ns	2 ns	N.A	6 ns	N.A
P_IDSEL	3 ns	2.81 ns	0 ns	- 0.50 ns	2 ns	N.A	6 ns	N.A
P_IRDYb	3 ns	2.22 ns	0 ns	-0.18 ns	2 ns	2.75 ns	6 ns	5.33 ns
P_PAR	3 ns	1.82 ns	0 ns	-0.35 ns	2 ns	2.75 ns	6 ns	5.31 ns
P_PERR	3 ns	2.73 ns	0 ns	- 0.43 ns	2 ns	2.74 ns	6 ns	5.32 ns
P_REQ	5 ns	N.A	0 ns	N.A	2 ns	2.77 ns	6 ns	5.34 ns
P_STOPb	3 ns	2.53 ns	0 ns	-0.17 ns	2 ns	2.75 ns	6 ns	5.32 ns
P_TRDYb	3 ns	2.37 ns	0 ns	-0.13 ns	2 ns	2.75 ns	6 ns	5.32 ns

1.10.3 VME 2eSST Timings

Following timings are given for ALMA2f in 2eSST mode.

For the Set up/ Hold timings of the ALMA2f DATA as input, the reference signal is DS1 in Write and DTACK in Read.

Note that the 2eSST specifies the timings at the Back plane connector.

Table 1-7. VME2eSST timing

Effective transfer rate	Speed selection VME2ESST_CTL[8:12]	Setup/Hold at source ALMA2f	number of VME_CLK (64 MHz or 60 MHz)	VME 2eSST Code (VITA 1.5 setup/hold at source connector)
146 MBytes/s	VERY_SLOW (0x01)	23.4 ns	3.5 VME_CLK (54,6 ns @ 64 MHz)	SST 160 (18 ns)
171 MBytes/s	SLOW (0x02)	15.6 ns	3 VME_CLK (46.8 ns @ 64 MHz)	SST 267 (10.8 ns)
205 MBytes/s	MEDIUM (0x04)	15.6 ns	2.5 VME_CLK (39.0 ns @ 64 MHz)	SST 267 (10.8 ns)
256 MBytes/s	FAST (0x08)	15.6 ns	2 VME_CLK (31,2 ns @ 64 MHz)	SST 267 (10.8 ns)
341 MBytes/s	ULTRA_FAST (0x10)	7.8 ns	1.5 VME_CLK (23,4 ns @ 64 MHz)	SST 320+
320 MBytes/s	ULTRA_FAST (0x10)	8.35 ns	1.5 VME_CLK (25.0 ns @ 60 MHz)	SST 320 (9 ns)

1.11 REGISTERS

1.11.1 Registers Space Description

ALMA2f Configuration Space

A space named «ALMA2f Configuration Space» of 256 entries (Bytes) is allocated to internal registers. All the internal registers are intrinsically in the little-endian byte ordering convention. In the following register description, bit 0 is the least significant bit of the register.

This Configuration Space is split in “Configuration Space Header” for register in address range address 0x00 to 0x3F, and in “Configuration Space Specific” for register in address range 0x40 to 0xFF.

A PCI master may access to “**Configuration Space Header**” with **PCI CONFIGURATION** cycles.

A PCI master may access to “**Configuration Space Specific**” with **PCI MEMORY** cycles (note : PCI Config access to this space are acknowledged : Write has no effect and Read return bad value)

A VME master may access to “Configuration Space Specific” with **VME A16 cycles** (“Configuration Space Header” is not accessible from VME side)

A second Register Space called “**Extended Register Space**” provides access to additional registers (CR/CSR registers, transaction flexibility registers,...)

A third 512 KB Register Space called **CR-CSR** (Configuration ROM-Control Status) is defined with a 0x8 00 00 offset for PCI access

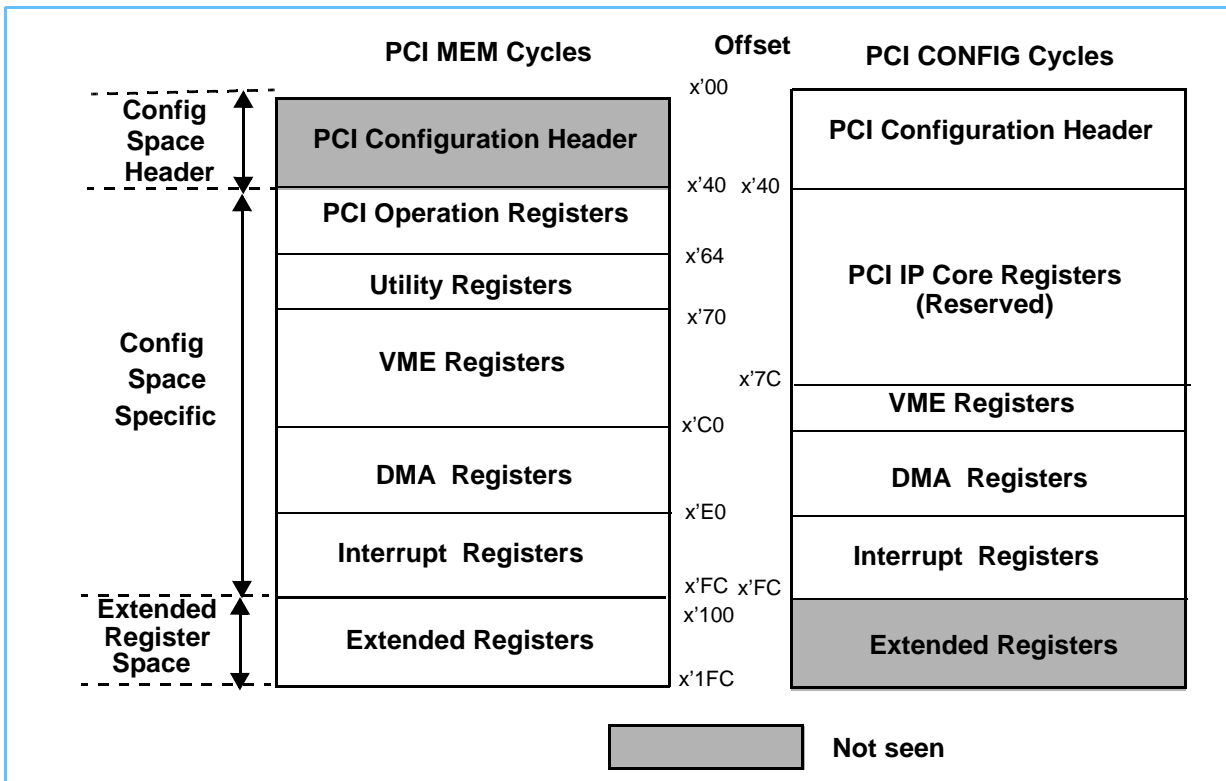

Figure 1-1. ALMA2f Configuration Space and Extended Space Register

1.11.2 Access to internal ALMA2f Registers

ALMA2f Identifying on VME Access to internal registers

On a VME A16 cycle, ALMA2f identifies its internal registers of the configuration space are accessed when it decodes its VME Slave channel A address (VME_SLVA register) as the target of that access.

All of the internal register set is accessible from VME bus via A24 CR/CSR transaction.

ALMA2f Identifying on PCI Access to internal registers

ALMA2f will respond to a PCI CONFIGURATION cycle ALMA2f is when its **P_IDSEL** input pin is asserted high.

ALMA2f identifies its internal registers are accessed via a PCI MEMORY cycle when it decodes its PCI Base Address Register no 1 (PCIH_BA1 register) as the target of the access.

Access to Reserved registers

When PCI or VME access are performed on an internal «Reserved» register, except otherwise noted, ALMA2f returns a value 0 on a Read, or takes no action (external common behavior) on a write.

Accessing the Mapping Table

The 1K-entry PCI Mapping Table can be accessed via the 2 following internal registers:

- Mapping Table index (**PCI_RAM_INDEX** register): counter which contains a Mapping Table entry address
- Mapping Table data (**PCI_RAM_DATA** register) virtual register: a write (or read) access to that register address will make ALMA2f to load the write data (or to return content) at Mapping Table offset pointed by the PCI_RAM_INDEX register.

To access the Mapping table, first the PCI_RAM_INDEX counter is loaded with a given starting offset, then, any subsequent write (or read) access to the PCI_RAM_DATA register address will automatically increment the counter. Current value of Mapping Table offset can be known at any time, by reading PCI_RAM_INDEX register.

1.11.3 ALMA2f Registers map

The following diagram shows the ALMA2f's register addressing organization. For compatibility with previous product, and because the 512KB CR-CSR (Configuration ROM - Control/Status Register) space starts at zero from the VME side, the **Configuration Space and Extended Register Space** can be accessed with 2 different addresses from the PCI side.

CR : Configuration ROM
 CSR : Control and Status Register

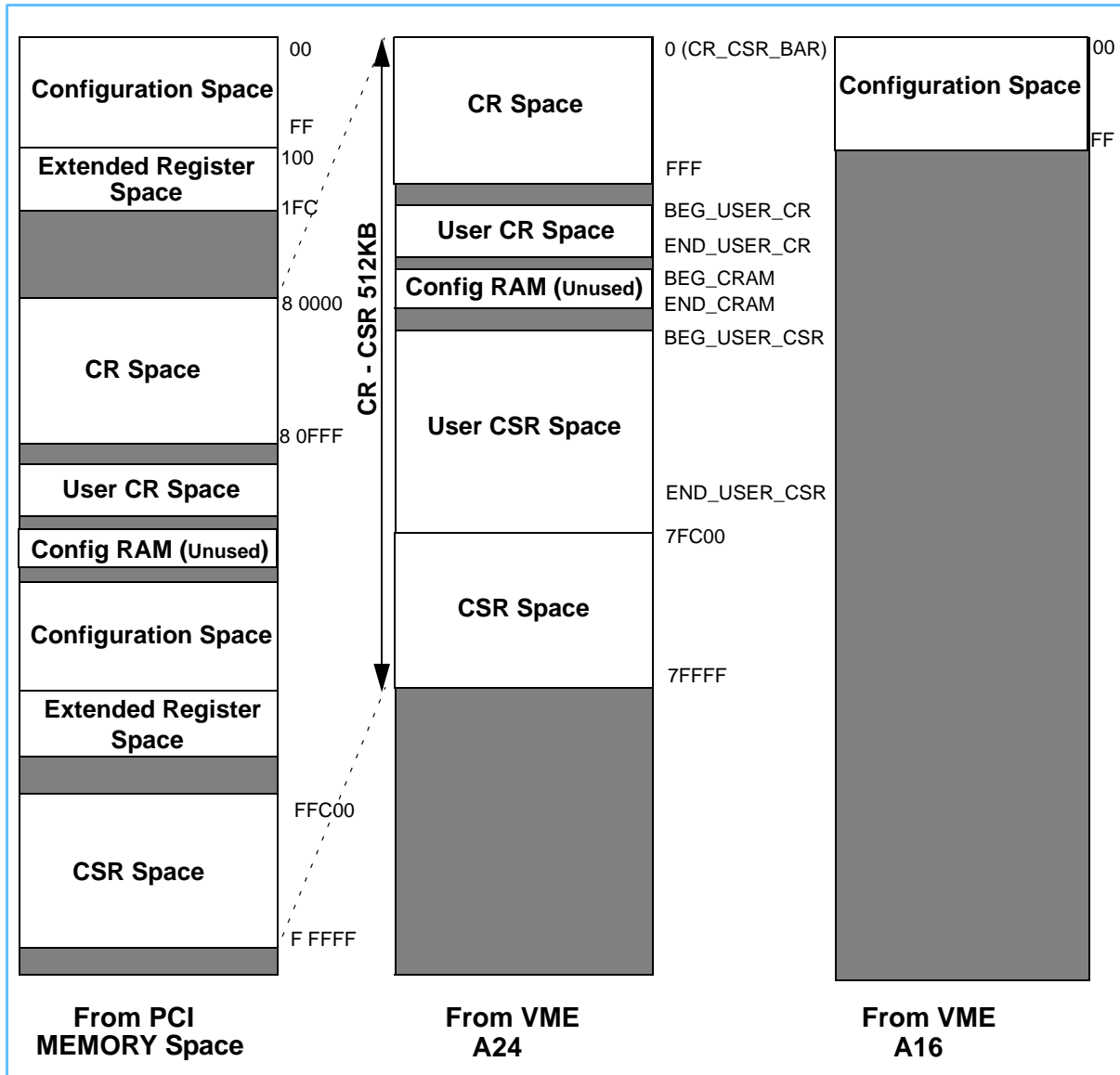

Figure 4 : ALMA2f Addressing Model.

Chapter 2. ALMA2f REGISTERS

#	Register space	Page	Address Offset	PCI Access	VME Access
1	PCI Configuration Header Registers	24	x'00 - 3C	PCI Config	A24
2	PCI Operation Registers	37	x'40 - 63	PCI Memory	A24
3	Utility Registers	46	x'64 - 6F	PCI Memory	A24
4	VME Registers	51	x'70 - BF	PCI Memory x'70-BF PCI Config x'80-BF	A24
5	DMA Registers	63	x'C0 - DF	PCI Configuration PCI Memory	A24
6	Interrupt Registers	73	x'E0 - FF		A24
7	Extended Registers	83	x'100 - 1FC	PCI Memory	A24
8	CSR (Control Status Registers)	108	x'7FF5F - 7FFFF	None	A24
9	CR (Configuration ROM)	112	x'03 - FFF	None	A24
10	PCI IP Core Registers	24	x'40 - 7C	PCI Config	None

2.0.1 PCI Configuration Header Registers

These registers are **accessible from the PCI Interface only using CONFIGURATION Cycles**.

Address	Size	Name	Use	Page	Notes
0x00	2 bytes	PCIH_VID	Vendor ID register	25	
0x02	2 bytes	PCIH_DID	Device ID register	25	
0x04	2 bytes	PCIH_CMD	PCI Command register	26	
0x06	2 bytes	PCIH_DSTAT	PCI Status register	27	
0x08	1 byte	PCIH_REVID	Revision ID register	28	
0x09	3 bytes	PCIH_CLSCD	PCI Class code register: Register-level programming interface - 0x9 Sub-Class code - offset 0xA Base class code - offset 0xB	28	
0x0C	1 byte	PCIH_CLS	Reserved	28	
0x0D	1 byte	PCIH_LT	PCI Latency timer register	28	
0x0E	1 byte	PCIH_HT	PCI Header type register	29	
0x0F	1 byte	PCIH_BIST	Reserved		
0x10	4 bytes	PCIH_BA1_SPACE	PCI Base Address register no1	30	
0x14	4 bytes	PCIH_BA2_SPACE	PCI Base Address register no 2	30	
0x18	4 bytes	PCIH_BA3_SPACE	PCI Base Address register no 3	30	
0x1C	4 bytes	PCIH_BA4_SPACE	PCI Base Address register no 4	30	
0x20	4 bytes	PCIH_BA5_SPACE	PCI Base Address register no 5	30	
0x24	4 bytes	PCIH_BA6_SPACE	PCI Base Address register no 6	30	
0x28	4 bytes	PCI_CIS	CARDBUS CIS POINTER	30	
0x2C	2 bytes	PCI_SUBVID	SUBSYSTEM Vendor ID	30	
0x2E	2 bytes	PCI_SUBDID	SUBSYSTEM Device ID	30	
0x30	4 bytes	PCI_ROM_BA	Expansion ROM Base Address	30	
0x34	1 bytes	PCI_CAP_PTR	Capability Pointer	30	
0x38	4 bytes	Reserved	Reserved		
0x3C	1 byte	PCIH_ITLINE	PCI Interrupt line register	32	
0x3D	1 byte	PCIH_ITPIN	PCI Interrupt pin register	32	
0x3E	1 byte	PCIH_MINGNT	PCI Minimum grant register	36	
0x3F	1 byte	PCIH_MAXLT	PCI Maximum latency register	36	

PCIH_VID

PCI Vendor ID register

Address from PCI interface:Config space : 0x00

IO/MEM space: not seen (Master Abort termination)

Not accessible from VME interface

Width: 16
Reset Value: 0x1059
Access type: Read Only

PCIH_VID

15	14	13	12	11	10	9	8	7	6	5	4	3	2	1	0
----	----	----	----	----	----	---	---	---	---	---	---	---	---	---	---

Bit(s)	Description
15 - 0	Vendor Identification Number Value 0x1059 (index 0x00 = 0x59, index 0x01 = 0x10)

PCIH_DID

PCI Device ID register

Address from PCI interface:Config space: 0x02

IO/MEM space: not seen (Master Abort termination)

Not accessible from VME interface

Width: 16
Reset Value: 0x9035
Access type: Read Only

PCIH_DID

15	14	13	12	11	10	9	8	7	6	5	4	3	2	1	0
----	----	----	----	----	----	---	---	---	---	---	---	---	---	---	---

Bit(s)	Description
15 - 0	Device Identification Number Value 0x9035 (index 0x02 = 0x35, index 0x03 = 0x09)

PCIH_CMD

PCI Command register

Address from PCI interface:Config space: 0x04

IO/MEM space: not seen (Master Abort termination)

Not accessible from VME interface

Width: 16
Reset Value: 0x0000
Access type: Read/Write
Recommended value: 0x0007

15	14	13	12	11	10	9	8	7	6	5	4	3	2	1	0
----	----	----	----	----	----	---	---	---	---	---	---	---	---	---	---

Bit(s)	Description
0	Enable PCI Slave IO space set to 0 ALMA2f PCI IO access are Disable set to 1 ALMA2f PCI IO access are Enable
1	Enable PCI Slave MEM space set to 0 ALMA2f PCI MEM access are Disable set to 1 ALMA2f PCI MEM access are Enable
2	PCI Master Enable set to 0 ALMA2f will never generate PCI access as a Master set to 1 ALMA2f may generate PCI access as a Master
3	Enable Special Cycle operation Read only set to 0, ALMA2f never monitor Special Cycle as a slave. Special cycles are not supported Although this bit is set to 0, ALMA2e is able to generate PCI Special Cycles.
4	Enable Memory Write & Invalidate operation Read only register set to 0. Memory Write & Invalidate is not supported Although this bit is set to 0, ALMA2e is able to generate and decode PCI Memory Write & Invalidate Cycles.
5	VGA Palette Snoop Read only register set to 0. ALMA2f is not a VGA device.
6	Enable Parity Error Response set to 0 ALMA2f masks detection of parity errors and P_PERRb is not asserted, although parity is still generated. set to 1 ALMA2f PCI bus parity errors detection is enable for all types of PCI transaction, including the following: PCI address bus parity errors PCI data bus parity errors while PCI master PCI data bus parity errors while PCI target
7	Address Stepping Control Read only register set to 0. ALMA2f does not support address stepping as a PCI master nor as a PCI target.
8	P_SERRb Enable. set to 0 ALMA2f never drives P_SERRb signal set to 1 Enable the assertion of P_SERRb when a PCI parity error is detected. The bit 6 (above) of the PCI command register must also be enable for parity error reporting.
9	Fast back to back enable. Read Only set to 0, ALMA2f is not able to generate fast back to back transaction.
15-10	Reserved, These bits are reserved and return zeros when read.

PCIH_DSTAT

PCI Device Status register

Address from PCI interface:Config space: 0x06

IO/MEM space: not seen (Master Abort termination)

Not accessible from VME interface

Width: 16
Reset Value: 0x0430
Access type: Read Only

15	14	13	12	11	10	9	8	7	6	5	4	3	2	1	0
----	----	----	----	----	----	---	---	---	---	---	---	---	---	---	---

Bit(s)	Description
3-0	Reserved, Return zeros when read.
4	Read only bit set to 1 - PCI interface implements a capabilities list
5	66 MHz Capability Read only register, this bit represents the value programmed in bit 9 of register DPT_CTL. 0 ALMA2f is not able to run PCI bus at 66 MHz. 1 ALMA2f is able to run PCI bus at 66 MHz.
6	Reserved, This bits are reserved and return zeros when read.
7	Fast back to back Capability Read only bit set to 0. Fast back to back is not supported
8	Data Parity Error Detected This bit is set when ALMA2f detects the following conditions: - ALMA2f Master of the PCI transaction and - P_PERRb signal active =0
10 - 9	DEVSEL# Timing = 10 This bits are Read only, ALMA2f always returns 10 when read. DEVSEL# Timing is slow
11	Signaled Target Abort Read only bit/ Reset when write to '1' This bit is set when ALMA2f as a slave, generates Target Abort.
12	Received Target Abort Read only bit/ Reset when write to '1' This bit is set when ALMA2f as a master generates a transaction terminated with Target-Abort.
13	Received Master Abort Read only bit/ Reset when write to '1' This bit is set when ALMA2f as a master generates a transaction (except for Special Cycle) terminated with Master Abort.
14	Signaled System Error Read only bit/ Reset when write to '1' This bit is set when ALMA2f as a Slave, asserts SERR#.
15	Detected Parity Error This bit is set by ALMA2f when one of these conditions occurs: - ALMA2f asserts P_SERRb signal - ALMA2f asserts P_PERRb signal - P_SERRb or P_PERRb signal asserted when bit 6 of register PCIH_CMD[6]=1

PCIH_REVID

PCI Revision ID register

Address from PCI interface:Config space: 0x08

IO/MEM space: not seen (Master Abort termination)

Not accessible from VME interface

Width: 8
Reset Value: 0x40
Access type: Read Only

PCIH_REVID

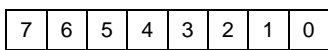

Bit(s)	Description
7 - 0	ALMA2f Revision ID Read only register set to 0x40

PCIH_CLSCD

PCI Class Code register

Address from PCI interface:Config space: 0x09

IO/MEM space: not seen (Master Abort termination)

Not accessible from VME interface

Width: 24
Reset Value: 0x008006
Access type: Read Only

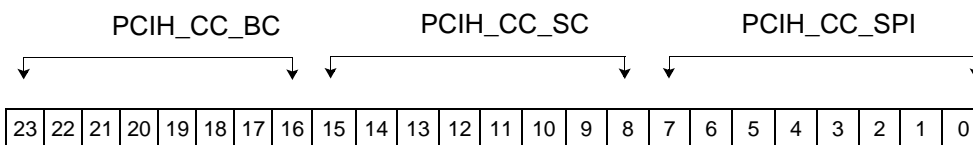

Bit(s)	Description
7 - 0	PCIH_CC_SPI : Register level programming interface Read only register set to 0x00
15 - 8	PCIH_CC_SC : Sub-Class Code register coded as "Other Bridge Device" Read only register set to 0x80
23 - 15	PCIH_CC_BC : Base-Class Code register coded as "Bridge Device" Read only register set to 0x06

PCIH_LT

PCI Latency Timer register

Address from PCI interface:Config space: 0x0D

IO/MEM space: not seen (Master Abort termination)

Not accessible from VME interface

Width: 8
Reset Value: 0x00
Access type: Read Only

PCIH_LT

7	6	5	4	3	2	1	0
---	---	---	---	---	---	---	---

Bit(s)	Description
7 - 0	ALMA2f has no Latency Timer Read only register set to 0x00

PCIH_HT

PCI Header Type register

Address from PCI interface:Config space: 0x0E

IO/MEM space: not seen (Master Abort termination)

Not accessible from VME interface

Width: 8
Reset Value: 0x30
Access type: Read Only

PCIH_HT

7	6	5	4	3	2	1	0
---	---	---	---	---	---	---	---

Bit(s)	Description
7 - 0	ALMA2f Header Type Read only register set to 0x30

PCIH_BA1_SPACE

PCI Base Address 1 register

Address from PCI interface:Config space: 0x10

IO/MEM space: not seen (Master Abort termination)

Not accessible from VME interface

Width: 32

Reset Value: 0xFFFFFFFF0

Access type: Read/Write

PCIH_BA1_SPACE

31	30	29	28	27	26	25	24	23	22	21	20	19	18	17	16	15	14	13	12	11	10	9	8	7	6	5	4	3	2	1	0
----	----	----	----	----	----	----	----	----	----	----	----	----	----	----	----	----	----	----	----	----	----	---	---	---	---	---	---	---	---	---	---

Bit(s)	Description
0	Memory Space is used for PCI BAR 1 Read only register set to 0
1	Reserved Read only register set to 0
2 - 7	These bits are always 0 since the minimum size of PCI BAR 1 is 256 bytes.
31 - 8	These bits determine where in PCI IO address space this region is located.

PCIH_BA2_SPACE

PCI Base Address 2 register

Address from PCI interface:Config space: 0x14

IO/MEM space: not seen (Master Abort termination)

Not accessible from VME interface

Width: 32
Reset Value: 0x00000000
Access type: Read/Write

PCIH_BA2_SPACE

31	30	29	28	27	26	25	24	23	22	21	20	19	18	17	16	15	14	13	12	11	10	9	8	7	6	5	4	3	2	1	0
----	----	----	----	----	----	----	----	----	----	----	----	----	----	----	----	----	----	----	----	----	----	---	---	---	---	---	---	---	---	---	---

Bit(s)	Description
0	<p>PCIH_BA2_SPACE (0: MEMORY Space; 1: IO Space) If PCI_BASPACE [6] = 0: PCIH_BA2_SPACE = 0 If PCI_BASPACE [6] = 1: PCIH_BA2_SPACE = PCI_BASPACE [BA2]</p> <p>* See register PCI_BASPACE at address 0x5B</p>
23 - 1	Reserved, This bits are reserved and return zeros when read.
31 - 24	<p>PCIH_BA2_OFFSET These bits determine where in PCI MEMORY or IO address space this region is located. The size of this base address register is programmable as follow: If PCI_ARS [EN] = 0, BAR size = 256Mbytes (bits[31:28] are R/W, bits[27:24] are RO) If PCI_ARS [EN] = 1: and If PCI_ARS [BA2] = 000 BAR size = 16Mbytes (bits [31:24] are R/W) If PCI_ARS [BA2] = 001 BAR size = 32Mbytes (bits [31:25] are R/W, bit[24] is RO) If PCI_ARS [BA2] = 010 BAR size = 64Mbytes (bits [31:26] are R/W, bit[25:24] are RO) If PCI_ARS [BA2] = 011 BAR size = 128Mbytes (bits [31:27] are R/W, bit[26:24] are RO) If PCI_ARS [BA2] = 100 BAR size = 256Mbytes (bits [31:28] are R/W, bit[27:24] are RO) If PCI_ARS [BA2] = 101 BAR size = 512Mbytes (bits [31:29] are R/W, bit[28:24] are RO) If PCI_ARS [BA2] = 110 BAR size = 1Gbytes (bits [31:30] are R/W, bit[29:24] are RO) If PCI_ARS [BA2] = 111 BAR size = 2Gbytes (bits [31] is R/W, bits[30:24] are RO)</p> <p>* See register PCI_ARS at address 0x58</p>

The definition of the following PCIH_BA(n)_SPACE registers is the same as the PCIH_BA2_SPACE.

- PCIH_BA3_SPACE** at address 0x18Reset= 0x0000 000
- PCIH_BA4_SPACE** at address 0x1CReset= 0x0000 000
- PCIH_BA5_SPACE** at address 0x20Reset= 0x0000 001
- PCIH_BA6_SPACE** at address 0x24Reset= 0x0000 001

PCI_CIS

Cardbus CIS Pointer

Address from PCI interface:Config space: 0x28

IO/MEM space: not seen (Master Abort termination)

Not accessible from VME interface

Width: 32

Reset Value: 0x00

Access type: Read/Write

PCI_CIS

31	30	29	28	27	26	25	24	23	22	21	20	19	18	17	16	15	14	13	12	11	10	9	8	7	6	5	4	3	2	1	0
----	----	----	----	----	----	----	----	----	----	----	----	----	----	----	----	----	----	----	----	----	----	---	---	---	---	---	---	---	---	---	---

Bit(s)	Description
31 - 0	tbd.

PCI_SUBVID

Subsystem Vendor ID

Address from PCI interface:Config space: 0x2C

IO/MEM space: not seen (Master Abort termination)

Not accessible from VME interface

Width: 16

Reset Value: 0x00

Access type: Read

PCI_SUBVID

15	14	13	12	11	10	9	8	7	6	5	4	3	2	1	0
----	----	----	----	----	----	---	---	---	---	---	---	---	---	---	---

Bit(s)	Description
15 - 0	TBD

PCI_SUBDID

Subsystem Device ID

Address from PCI interface: Config space: 0x2E

IO/MEM space: not seen (Master Abort termination)

Not accessible from VME interface

Width: 16
Reset Value: 0x00
Access type: Read

PCI_SUBDID

15	14	13	12	11	10	9	8	7	6	5	4	3	2	1	0
----	----	----	----	----	----	---	---	---	---	---	---	---	---	---	---

Bit(s)	Description
15 - 0	TBD

PCI_ROM_BA

Expansion ROM Base Address

Address from PCI interface:Config space: 0x30

IO/MEM space: not seen (Master Abort termination)

Not accessible from VME interface

Width: 32
Reset Value: 0x00
Access type: Read/Write

PCI_ROM_BA

31	30	29	28	27	26	25	24	23	22	21	20	19	18	17	16	15	14	13	12	11	10	9	8	7	6	5	4	3	2	1	0
----	----	----	----	----	----	----	----	----	----	----	----	----	----	----	----	----	----	----	----	----	----	---	---	---	---	---	---	---	---	---	---

Bit(s)	Description
31 - 0	tbd.

0x30	4 bytes	PCI_ROM_BA	Expansion ROM Base Address
0x34	4 bytes	PCI_CAP_PTR	Capability Pointer

PCI_CAP_PTR

Capability Pointer

Address from PCI interface:Config space: 0x34

IO/MEM space: not seen (Master Abort termination)

Not accessible from VME interface

Width: 8
Reset Value: 0x00
Access type: Read/Write

PCI_CAP_PTR

7	6	5	4	3	2	1	0
---	---	---	---	---	---	---	---

Bit(s)	Description
7 - 0	TBD

PCIH_ITLINE

PCI Interrupt Line register

Address from PCI interface:Config space: 0x3C

IO/MEM space: not seen (Master Abort termination)

Not accessible from VME interface

Width: 8
Reset Value: 0x00
Access type: Read/Write

PCIH_ITLINE

7	6	5	4	3	2	1	0
---	---	---	---	---	---	---	---

Bit(s)	Description
7 - 0	Routing path of the existing PCI Interrupt pin to Interrupt system pin.

PCIH_ITPIN

PCI Interrupt Pin register

Address from PCI interface:Config space: 0x3D

IO/MEM space: not seen (Master Abort termination)

Not accessible from VME interface

Width: 8
Reset Value: 0x01
Access type: Read Only

PCIH_ITPIN

7	6	5	4	3	2	1	0
---	---	---	---	---	---	---	---

Bit(s)	Description
7 - 0	the PCI INTA# interrupt pin is enable. INTA# is an output of ALMA2f Read only register set to 0x01

PCIH_MINGNT

PCI Minimum Grant register

Address from PCI interface:Config space: 0x3E

IO/MEM space: not seen (Master Abort termination)

Not accessible from VME interface

Width: 8
Reset Value: 0x00
Access type: Read Only

PCIH_MINGNT

7	6	5	4	3	2	1	0
---	---	---	---	---	---	---	---

Bit(s)	Description
7 - 0	Read only register set to 0x00

PCIH_MAXLAT

PCI Maximum Latency register

Address from PCI interface:Config space: 0x3F

IO/MEM space: not seen (Master Abort termination)

Not accessible from VME interface

Width: 8
Reset Value: 0x00
Access type: Read Only

PCIH_MAXLAT

7	6	5	4	3	2	1	0
---	---	---	---	---	---	---	---

Bit(s)	Description
7 - 0	Read only register set to 0x00

2.0.2 PCI Operation Registers

Address	Size	Name	Use	Page	Notes
0x40	1 byte	PCI_BUSNUM	PCI Bus Number register	38	
0x41	1 byte	PCI_SUBNUM	PCI Sub-Bus Number register	38	
0x42	2 bytes	PCI_ARB	PCI Bus Arbiter Control register	39	
0x44	2 bytes	PCI_SCTRL	PCI Specific Control register	39	
0x46	2 bytes		Reserved		
0x48	4 bytes	VME_SEM0-3	VME Semaphore Registers	56	
0x4C	4 bytes	PCI_CFGADD	PCI Configuration Address register	40	
0x50	4 bytes	PCI_CFGDATA	PCI Configuration Data register	41	
0x54	4 bytes	PCI_INTACK / PCI_SPECIAL	PCI Interrupt Acknowledge register / Special Cycle register	41	
0x58	2 bytes	PCI_ARS	PCI Slave Address Range Size register	42	
0x5A	1 byte		Reserved		
0x5B	1 byte	PCI_BASPACE	PCI Base Address Space register	43	
0x5C	2 bytes	PCI_RAMINDEX	Mapping Table Index register	44	
0x5E	1 byte		Reserved		
0x5F	1 byte	PCI_RAMDFLT	Mapping Table Default register	44	
0x60	4 bytes	PCI_RAMDATA	Mapping Table Data register	44	

PCI_BUSNUM

PCI Bus Number register

Address from PCI interface:Config space: not seen (access to PCI IP Core Register Space)

MEMORY space: PCIH_BA1_SPACE + 0x40

Address from VME interface:A16 space: VME_SLVA + 0x40

A24 space: CR_CSR_BAR + BEG_USER_CSR + 0x40

Width: 8
Reset Value: 0x00
Access type: Read/Write

7	6	5	4	3	2	1	0
---	---	---	---	---	---	---	---

Bit(s)	Description
7 - 0	The PCI Bus Number register is used to identify the number of the PCI bus ALMA2f is connect to.

PCI_SUBNUM

PCI Sub-Bus Number register

PCI Bus Number register

Address from PCI interface:Config space: not seen (access to PCI IP Core Register Space)

MEMORY space : PCIH_BA1_SPACE + 0x41

Address from VME interface:A16 space: VME_SLVA + 0x41

A24 space: CR_CSR_BAR + BEG_USER_CSR + 0x41

Width: 8
Reset Value: 0x00
Access type: Read/Write

7	6	5	4	3	2	1	0
---	---	---	---	---	---	---	---

Bit(s)	Description
7 - 0	The PCI Sub-Bus Number register is used to identify the number of the last hierarchical bus behind ALMA2f.

PCI_ARB

PCI Bus Number register

Address from PCI interface: Config space: not seen (access to PCI IP Core Register Space)

MEMORY space : PCIH_BA1_SPACE + 0x42

Address from VME interface: A16 space: VME_SLVA + 0x42

A24 space: CR_CSR_BAR + BEG_USER_CSR + 0x42

Width: 16

Reset Value: 0x0000

Access type: Read Only

PCI_ARB

15	14	13	12	11	10	9	8	7	6	5	4	3	2	1	0
----	----	----	----	----	----	---	---	---	---	---	---	---	---	---	---

Bit(s)	Description
0	PCI Arbiter mode: ALMA2f has no longer internal PCI arbiter. This bit is Read/Write and has no effect.
15 - 1	Reserved, This bits are reserved and return zeros when read.

PCI_SCTRL

PCI Specific Control register

PCI Bus Number register

Address from PCI interface: Config space: not seen (access to PCI IP Core Register Space)

MEMORY space : PCIH_BA1_SPACE + 0x44

Address from VME interface: A16 space: VME_SLVA + 0x44

A24 space: CR_CSR_BAR + BEG_USER_CSR + 0x44

Width: 16

Reset Value: 0x8000

Access type: Read / Write

15	14	13	12	11	10	9	8	7	6	5	4	3	2	1	0
----	----	----	----	----	----	---	---	---	---	---	---	---	---	---	---

Bit(s)	Description
0	PCI bus size, Read Only register. 0: ALMA2f is connected to a PCI 32 bit bus 1: ALMA2f is connected to a PCI 64 bit bus
1 - 11	Reserved, Return zeros when read.
12	PCI_SCTRL_LAT16EN (for debug purpose) Must be left to 0
13	PCI_SCTRL_TARGLATEN(for debug purpose) Must be left to 0
14	PCI_SCTRL_NORETRY: 0: ALMA2f retries PCI access to internal registers if the VME interface is busy. 1: ALMA2f does not retry PCI access to internal registers
15	PCI_SCTRL_NOMAP: 0: Mapping table is used for PCI to VME access 1: Mapping table is not used, PCI_RAMDFLT is used for PCI to VME access.

PCI_CFGADD

PCI Configuration Address register

PCI Bus Number register

Address from PCI interface: Config space: not seen (access to PCI IP Core Register Space)

MEMORY space : PCIH_BA1_SPACE + 0x4C

Address from VME interface: A16 space: VME_SLVA + 0x4C

A24 space: CR_CSR_BAR + BEG_USER_CSR + 0x4C

Width: 32

Reset Value: 0x00000000

Access type: Read/Write

PCI_CFGADD

31	30	29	28	27	26	25	24	23	22	21	20	19	18	17	16	15	14	13	12	11	10	9	8	7	6	5	4	3	2	1	0
----	----	----	----	----	----	----	----	----	----	----	----	----	----	----	----	----	----	----	----	----	----	---	---	---	---	---	---	---	---	---	---

Bit(s)	Description
1 - 0	Reserved, Returns zeros when read.
7 - 2	PCI_CFGADD_REGNUM: Register Number of the external device to configured
10 - 8	PCI_CFGADD_FNUM: Function Number of the external device to configured
15 - 11	<p>PCI_CFGADD_DEVNUM: Device Number of the external device to configured</p> <p>0x00: PCI device 0, PCI_ADD[11] is active</p> <p>0x01: PCI device 1, PCI_ADD[12] is active</p> <p>0x02: PCI device 2, PCI_ADD[13] is active</p> <p>0x03: PCI device 3, PCI_ADD[14] is active</p> <p>0x04: PCI device 4, PCI_ADD[15] is active</p> <p>0x05: PCI device 5, PCI_ADD[16] is active</p> <p>0x06: PCI device 6, PCI_ADD[17] is active</p> <p>0x07: PCI device 7, PCI_ADD[18] is active</p> <p>0x08: PCI device 8, PCI_ADD[19] is active</p> <p>0x09: PCI device 9, PCI_ADD[20] is active</p> <p>0x0A: PCI device 10, PCI_ADD[21] is active</p> <p>0x0B: PCI device 11, PCI_ADD[22] is active</p> <p>0x0C: PCI device 12, PCI_ADD[23] is active</p> <p>0x0D: PCI device 13, PCI_ADD[24] is active</p> <p>0x0E: PCI device 14, PCI_ADD[25] is active</p> <p>0x0F: PCI device 15, PCI_ADD[26] is active</p> <p>0x10: PCI device 16, PCI_ADD[27] is active</p> <p>0x11: PCI device 17, PCI_ADD[28] is active</p> <p>0x12: PCI device 18, PCI_ADD[29] is active</p> <p>0x13: PCI device 19, PCI_ADD[30] is active</p> <p>0x14: PCI device 20, PCI_ADD[31] is active</p>
23 - 16	PCI_CFGADD_BUSNUM: PCI bus number of the external device to configured
30 - 24	Reserved, Returns zeros when read.
31	PCI_CFGADD_EN: PCI Configuration Enable

PCI_CFGDATA

PCI Configuration Address register

PCI Bus Number register

Address from PCI interface:Config space: not seen (access to PCI IP Core Register Space)

MEMORY space : PCIH_BA1_SPACE + 0x50

Address from VME interface:A16 space: VME_SLVA + 0x50

A24 space: CR_CSR_BAR + BEG_USER_CSR + 0x50

Width: 32

Reset Value: None, Virtual register.

Access type: Read/Write

PCI_CFGDATA

31	30	29	28	27	26	25	24	23	22	21	20	19	18	17	16	15	14	13	12	11	10	9	8	7	6	5	4	3	2	1	0
----	----	----	----	----	----	----	----	----	----	----	----	----	----	----	----	----	----	----	----	----	----	---	---	---	---	---	---	---	---	---	---

Bit(s)	Description
31 - 0	<p>PCI_CFGDATA: Virtual register. A Read or Write to this register from the VME bus, results in a PCI Configuration cycle read or write initiated by ALMA2f with the address defined in register PCI_CFGADD. Note: A read from the PCI to this register returns 0, a write from the PCI to this register has no effect.</p>

PCI_INTACK/SPECIAL

PCI Interrupt Acknowledge / Special Cycle register

PCI Bus Number register

Address from PCI interface:Config space: not seen (access to PCI IP Core Register Space)

MEMORY space : PCIH_BA1_SPACE + 0x54

Address from VME interface:A16 space: VME_SLVA + 0x54

A24 space: CR_CSR_BAR + BEG_USER_CSR + 0x54

Width: 32

Reset Value: None, Virtual register.

Access type: Read/Write

PCI_INTACK/SPECIAL

31	30	29	28	27	26	25	24	23	22	21	20	19	18	17	16	15	14	13	12	11	10	9	8	7	6	5	4	3	2	1	0
----	----	----	----	----	----	----	----	----	----	----	----	----	----	----	----	----	----	----	----	----	----	---	---	---	---	---	---	---	---	---	---

Bit(s)	Description
31 - 0	<p>PCI_INTACK/SPECIAL: Virtual register. When this register is read from the VME bus, ALMA2f initiates a PCI Interrupt Acknowledge cycle. When this register is written from the VME bus, ALMA2f initiates a PCI Special Cycle. Note: A read from the PCI to this register returns 0, a write from the PCI to this register has no effect.</p>

PCI_ARS

PCI Slave Address Range Size register

PCI Bus Number register

Address from PCI interface: Config space: not seen (access to PCI IP Core Register Space)

MEMORY space : PCIH_BA1_SPACE + 0x58

Address from VME interface: A16 space: VME_SLVA + 0x58

A24 space: CR_CSR_BAR + BEG_USER_CSR + 0x58

Width: 16

Reset Value: **0x0000** ~~0x4924~~

Access type: Read / Write

PCI_ARS

15	14	13	12	11	10	9	8	7	6	5	4	3	2	1	0
----	----	----	----	----	----	---	---	---	---	---	---	---	---	---	---

Bit(s)	Description
2 - 0	PCI_ARS_BA6: PCI Base Address 6 size: 000: 16 MB 100: 256 MB 001: 32 MB 101: 512 MB 010: 64 MB 110: 1 GB 011: 128 MB 111: BAR is disabled 2-GB
5 - 3	PCI_ARS_BA5: PCI Base Address 5 size: 000: 16 MB 100: 256 MB 001: 32 MB 101: 512 MB 010: 64 MB 110: 1 GB 011: 128 MB 111: BAR is disabled 2-GB
8 - 6	PCI_ARS_BA4: PCI Base Address 4 size: 000: 16 MB 100: 256 MB 001: 32 MB 101: 512 MB 010: 64 MB 110: 1 GB 011: 128 MB 111: BAR is disabled 2-GB
11 - 9	PCI_ARS_BA3: PCI Base Address 3 size: 000: 16 MB 100: 256 MB 001: 32 MB 101: 512 MB 010: 64 MB 110: 1 GB 011: 128 MB 111: BAR is disabled 2-GB
14 - 12	PCI_ARS_BA2: PCI Base Address 2 size: 000: 16 MB 100: 256 MB 001: 32 MB 101: 512 MB 010: 64 MB 110: 1 GB 011: 128 MB 111: BAR is disabled 2-GB
15	PCI_ARS_EN: 0: PCI Base address are fixed and equal to 16 MB 256MB . 1: PCI Base address size are programmable and given by registers PCI_ARS_BAx above.

PCI_BASPACE

PCI Base Address Space register

PCI Bus Number register

Address from PCI interface: Config space: not seen (access to PCI IP Core Register Space)

MEMORY space : PCIH_BA1_SPACE + 0x5B

Address from VME interface: A16 space: VME_SLVA + 0x5B

A24 space: CR_CSR_BAR + BEG_USER_CSR + 0x5B

Width: 8

Reset Value: 0x40

Access type: Read/Write

PCI_BASPACE

7	6	5	4	3	2	1	0
---	---	---	---	---	---	---	---

Bit(s)	Description
0	PCI_BASPACE_BA6 0: Base Address 6 is mapped in MEMORY Space 1: Base Address 6 is mapped in I/O Space Note: PCI BAR 6 is fixed and mapped to I/O MEMORY Space if PCI_BASPACE_EN = 0.
1	PCI_BASPACE_BA5 0: Base Address 5 is mapped in MEMORY Space 1: Base Address 5 is mapped in I/O Space Note: PCI BAR 5 is fixed and mapped to I/O MEMORY Space if PCI_BASPACE_EN = 0.
2	PCI_BASPACE_BA4 0: Base Address 4 is mapped in MEMORY Space 1: Base Address 4 is mapped in I/O Space Note: PCI BAR 4 is fixed and mapped to I/O MEMORY Space if PCI_BASPACE_EN = 0.
3	PCI_BASPACE_BA3 0: Base Address 3 is mapped in MEMORY Space 1: Base Address 3 is mapped in I/O Space Note: PCI BAR 3 is fixed and mapped to I/O MEMORY Space if PCI_BASPACE_EN = 0.
4	PCI_BASPACE_BA2 0: Base Address 2 is mapped in MEMORY Space 1: Base Address 2 is mapped in I/O Space Note: PCI BAR 2 is fixed and mapped to I/O MEMORY Space if PCI_BASPACE_EN = 0.
5	PCI_BASPACE_EN: Programmable PCI Space Enable 0: mapping space for all PCI BAR is fixed. 1: PCI BAR 2, 3, 4, 5, 6 mapping space are programmable
6	PCI_BA1_EN: Enable access to ALMA2f registers through PCI BAR BA1 0: Only ALMA2f Configuration Space registers is accessible from the PCI (Compatibility with previous ALMA_V64 product) 1: All spaces registers are accessible from the PCI.
7	Reserved, Return zero when Read.

PCI_RAMINDEX

Mapping Table Index Register

PCI Bus Number register

Address from PCI interface: Config space: not seen (access to PCI IP Core Register Space)

MEMORY space : PCIH_BA1_SPACE + 0x5C

Address from VME interface: A16 space: VME_SLVA + 0x5C

A24 space: CR_CSR_BAR + BEG_USER_CSR + 0x5C

Width: 16

Reset Value: 0x00000000

Access type: Read/Write

PCI_RAMINDEX

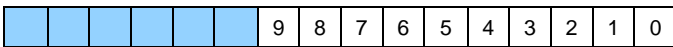

Bit(s)	Description
9 - 0	PCI_RAMINDEX[9:0] 1K-entry Mapping Table address
15 - 10	Reserved

PCI_RAMDFLT

Mapping Table Default Register

PCI Bus Number register

Address from PCI interface: Config space: not seen, access ends normaly

MEMORY space : PCIH_BA1_SPACE + 0x5F

Address from VME interface: A16 space: VME_SLVA + 0x5F

A24 space: CR_CSR_BAR + BEG_USER_CSR + 0x5F

Width: 8

Reset Value: 0x00000000

Access type: Read/Write

PCI_RAMDFLT

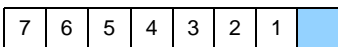

Bit(s)	Description
0	Reserved
25	PCI_RAMDFLT_VAL 1: ALMA2f decodes PCI MEMORY or I/O accesses. 0: ALMA2f does not respond to PCI MEMORY or I/O accesses
31 - 26	PCI_RAMDFLT_AM [5:0] VME cycle Address Modifiers [5:0]

2.0.3 ALMA2f Utility Registers

These Utility Registers are used mainly during the initialization phase at the Power-On of the card using ALMA2f.

Address	Size	Name	Use	Page	Notes
0x64	4 bytes	UTIL_RST	VME Reset Control & Watchdog Timer Register	47	
0x68	4 bytes	UTIL_VMECNTL	VME System Control Register	48	
0x6C	4 bytes	UTIL_ERRSTA	Error Status Register	49	

UTIL_RST

VME Reset Control & Watchdog Timer Register

PCI Bus Number register

Address from PCI interface: Config space: not seen (access to PCI IP Core Register Space)

MEMORY space : PCIH_BA1_SPACE + 0x64

Address from VME interface: A16 space: VME_SLVA + 0x64

A24 space: CR_CSR_BAR + BEG_USER_CSR + 0x64

Width: 32

Reset Value: 0x00000000

Access type: Read/Write

UTIL_RST

31	30	29	28	27	26	25	24	23	22	21	20	19	18	17	16	15	14	13	12	11	10	9	8	7	6	5	4	3	2	1	0
----	----	----	----	----	----	----	----	----	----	----	----	----	----	----	----	----	----	----	----	----	----	---	---	---	---	---	---	---	---	---	---

Bit(s)	Description
0	UTIL_RST_LOC2VME Propagation of local reset (RESETINb) to the VME (SYSRESET*) 0 = no, 1 = yes
7 - 1	Reserved
9 - 8	UTIL_RST_ADD[1:0] Generation of local reset and/or a VME reset 00 De-activation of RESETOUb independently of the time-out 01 Activation of SYSRESET* for 201 ms 10 Activation of RESETOUb for 201 ms maximum. 11 Activation of SYSRESET* and RESOUTb
15 - 10	Reserved
31 - 16	UTIL_WDG_VALUE[15:0] Watchdog Timer value (ms) = UTIL_WDG_VALUE[15:0] multiplied by 4 - Writing a value different of zero in this register restart the Timer - Writing a zero inhibits the Watchdog function

UTIL_VMECNTL

VME System Control Register

PCI Bus Number register

Address from PCI interface: Config space: not seen (access to PCI IP Core Register Space)

IO space: not seen, access ends with Master Abort termination

MEMORY space : PCIH_BA1_SPACE + 0x68

Address from VME interface: A16 space: VME_SLVA + 0x68

A24 space: CR_CSR_BAR + BEG_USER_CSR + 0x68

Width: 32

Reset Value: 0x00000000

Access type: Read/Write

UTIL_VMECNTL

31	30	29	28	27	26	25	24	23	22	21	20	19	18	17	16	15	14	13	12	11	10	9	8	7	6	5	4	3	2	1	0
----	----	----	----	----	----	----	----	----	----	----	----	----	----	----	----	----	----	----	----	----	----	---	---	---	---	---	---	---	---	---	---

Bit(s)	Description
0	<p>UTIL_SYSFAIL At the POWER ON RESET the SYSFAIL* is not activated if the PWSR_CTL signal is active. In all other cases of RESET the SYSFAIL* is activated. Read: Gives state of signal SYSFAIL* of the VME Bus (1 = active) Write 1: Signal SYSFAIL* generated by ALMA2f is activated Write 0: Signal SYSFAIL* generated by ALMA2f is de-activated</p>
7 - 1	Reserved
8	<p>UTIL_SYSRESET State of signal SYSRESET* of the VME Bus (0: non active, 1: active)</p>
15 - 9	Reserved
23 - 16	<p>UTIL_CONFIG [7:0] The state of VME Address input signals V_A [8:1] is loaded in this register during Resets</p>
24	Reserved
31 - 25	Reserved

UTIL_ERRSTA

Error Status Register

PCI Bus Number register

Address from PCI interface: Config space: not seen (access to PCI IP Core Register Space)

MEMORY space : PCIH_BA1_SPACE + 0x6C

Address from VME interface: A16 space: VME_SLVA + 0x6C

A24 space: CR_CSR_BAR + BEG_USER_CSR + 0x6C

Width: 32

Reset Value: 0x00000000

Access type: Read/Write
UTIL_ERRSTA

31	30	29	28	27	26	25	24	23	22	21	20	19	18	17	16	15	14	13	12	11	10	9	8	7	6	5	4	3	2	1	0
----	----	----	----	----	----	----	----	----	----	----	----	----	----	----	----	----	----	----	----	----	----	---	---	---	---	---	---	---	---	---	---

Bit(s)	Description
Error bits definition: When at 0 no error reported	
0	VME_arb_timeoutfail When ALMA2f is VME system Controller, If after an arbitrated bus grant, no VME agent has asserted a V_BBSYb within 8 mS
1	VME_mst_nodata ALMA2f is the target of a PCI single data access for which all PCI Byte Enables lines are inactive (no data to transfer).
2	VME_slv_sizefail ALMA2f is the target of a VME BLT or MBLT access for which data beat size is not D32 or D64.
3	VME_slv_wpostfail ALMA2f is the target of a VME write posted access and a PCI error occurs (PCI cycle completes with a Target or a Master Abort).
4	VME_slv_writfail ALMA2f is the target of a VME write (non-posted) access and a PCI error occurs (PCI cycle completes with a Target or a Master Abort).
5	VME_slv_readfail ALMA2f is the target of a VME read access in Read-Ahead mode (PCI data are prefetched) and a PCI error occurs (PCI cycle completes with a Target or a Master Abort).
6	VME_tim_dtbfail ALMA2f is System Controller. A data transfer time-out occurs (no VME slave is responding at time out defined by register VME_TIM).
7	UTIL_wdg_reset A reset has been generated by ALMA2f Watchdog function (the Watchdog timer defined by UTIL_RST[31:16] register has not been cleared before time out).
8	IT_mng_avitfail PCI_AVITb pin is asserted, ALMA2f translates the interrupt into a VME cycle which completes with a Bus Error.
9	PCI_seq_befail ALMA2f is the target of a PCI access for which the PCI Byte Enables pattern is specifying non-adjacent valid bytes (for example: PCI reading/writing only the byte3 and byte1 of the 4-byte data pattern, byte2 and byte0 being not transferred).
10	PCI_seq_sizefail ALMA2f is the target of a PCI burst access for which data beat size is not equal to 32 bits.
11	PCI_seq_wpostfail ALMA2f is the target of a PCI write posted access and a VMEbus Error occurs.
12	PCI_seq_writfail ALMA2f is the target of a PCI write (non-posted) access and a VMEbus Error occurs.
13	PCI_seq_readfail ALMA2f is the target of a PCI read access (Read-Ahead mode enabled or not) and a VMEbus Error occurs.

17-14	Reserved
18	DMA_seq_vmefail channel 1 A VMEbus Error occurred during DMA (Channel 1).
19	DMA_seq_vmefail channel 0 A VMEbus Error occurred during DMA (Channel 0).
20	DMA_seq_pcifail channel 1 A PCI error occurred (Target or Master Abort) during DMA (Channel 1).
21	DMA_seq_pcifail channel 0 A PCI error occurred (Target or Master Abort) during DMA (Channel 0).
31 - 22	Reserved

2.0.4 ALMA2f VME Registers

Address	Size	Name	Use	Page	Notes
0x48	4 bytes	VME_SEM0-3	VME Semaphore Registers	56	
0x70	1 bytes	VME_REQ	VME Request Control Register	52	
0x71	1 bytes	VME_ARB	VME Bus Arbitration Control Register	53	
0x72	1 bytes	VME_TIM	VME Data Transfer Timer Register	54	
0x73	1 bytes	VME_MST	VME Master Control Register	55	
0x74	4 bytes	VME_SEM0-3	VME Semaphore Registers	56	
0x78	1 bytes	VME_SLVA	VME Slave Channel A Address Register	57	
0x7A	1 bytes	VME_SLV	VME Slave Control Register	58	
0x7B	2 bytes	VME_PERF	VME Master Performance Control Register	59	
0x7C	4 bytes	VME_SLVA_LEBE	VME Slave Channel A Byte Ordering Control Reg	60	
0x80	8 bytes	VME_SLV0	VME Slave Channel 0 Control Register	61	
0x88	8 bytes	VME_SLV1	VME Slave Channel 1 Control Register	61	
0x90	8 bytes	VME_SLV2	VME Slave Channel 2 Control Register	61	
0x98	8 bytes	VME_SLV3	VME Slave Channel 3 Control Register	61	
0xA0	8 bytes	VME_SLV4	VME Slave Channel 4 Control Register	61	
0xA8	8 bytes	VME_SLV5	VME Slave Channel 5 Control Register	61	
0xB0	8 bytes	VME_SLV6	VME Slave Channel 6 Control Register	61	
0xB8	8 bytes	VME_SLV7	VME Slave Channel 7 Control Register	61	

VME_REQ

VME Request Control Register

PCI Bus Number register

Address from PCI interface: Config space: not seen (access to PCI IP Core Register Space)

MEMORY space : PCIH_BA1_SPACE + 0x70

Address from VME interface: A16 space: VME_SLVA + 0x70

A24 space: CR_CSR_BAR + BEG_USER_CSR + 0x70

Width: 8

Reset Value: 0x00

Access type: Read/Write

7	6	5	4	3	2	1	0
---	---	---	---	---	---	---	---

Bit(s)	Description
0 - 1	VME_REQ_LEVEL[1:0]: Reset by POWER_ON_RESET Request level on the VME bus done by ALMA2f (BR3-0*)
2	VME_REQ_FAIRMODE 0: No Fair mode 1: Fair mode ALMA2f Doesn't assert a VME request if another request is already pending on the same level
3	VME_REQ_FAIRTIMEOUT 0: No Fair mode Time-out 1: Fair mode Time-out: when the 20 micro-seconds time-out expires ALMA2f is no longer in fair mode.
4 - 5	VME_REQ_RELEASE[1:0] VME bus release mode: 00 ROR Release on Request 01 RWD Release When Done 10 ROC Release On Clear 11 RNE Release Never
6	VME_REQ_LBR Software VME bus request, same function as pin BRLOCb (External VMEbus Requesting feature)
7	VME_REQ_LBG Software VME bus grant, same function as pin BGLOCb (belongs to the External VMEbus Requesting feature protocol)

VME_ARB

VME Bus Arbitration Control register

Address from PCI interface: Config space: not seen (access to PCI IP Core Register Space)

MEMORY space : PCIH_BA1_SPACE + 0x71

Address from VME interface: A16 space: VME_SLVA + 0x71

A24 space: CR_CSR_BAR + BEG_USER_CSR + 0x71

Width: 8
Reset Value: 0x00
Access type: Read/Write

7	6	5	4	3	2	1	0
---	---	---	---	---	---	---	---

Bit(s)	Description
0	VME_ARB_SYSCONTB R/O Reset by POWER_ON_RESET 0: sets ALMA2f as VME system controller (external pin)
1	VME_ARB_TYPE: ALMA2f VMEbus arbiter arbitration type: 0: Fixed priority Highest priority is Req 3 - Lowest Req 0 1: Rotating priority
2	VME_ARB_BCLR 0: when ALMA2f is VME system controller, it never drives the V_BCLRb signal. 1: when ALMA2f is VME system controller, it drives the V_BCLRb signal if - in Fixed priority mode, a higher priority request occurs - in Rotating priority a new request occurs.
3	VME_REQ_ROUND 0: Fixed Priorities between internal bus requests: #1: AVITb pin assertion (highest priority) #2: PCI access #3: DMA start (lowest priority) 1: Rotating Priority between above internal bus requests.
4	Reserved_2 - Must be held to zero (otherwise result is unpredictable)
5	VME_REQ_RORTIMER This bit is operating when ALMA2f bus requester is set in the ROR mode (Release On Request). 0: ALMA2f drives the VMEbus permanently. 1: ALMA2f drives the VMEbus for only 20 microseconds. Recommended setting is 0.
6	VME_REQ_NORELWDMA This bit is operating when the External VMEbus Requesting feature is used. Recommended setting is 0. 0: A DMA internal request going active makes ALMA2f to ask the External VMEbus requester to release the VMEbus (by de-asserting pin BGLOCb) 1: A DMA internal request going active does not make ALMA2f to ask the External VMEbus requester to release the VMEbus: DMA request will be serviced only after the VMEbus master decided to release the bus.
7	VME_REQ_FREEMODE This bit is operating when the External VMEbus Requesting feature is used. Recommended setting is 0. 1: The External VMEbus Request (via pin BRLOC or bit VME_REQ_LBR) has the highest priority over DMA internal request: is serviced immediately. 0: The External VMEbus Request has a rotating priority with the DMA internal request: is serviced after ALMA2f has serviced a pending DMA request.

VME_TIM

VME Data Transfer Timer Register

Address from PCI interface: Config space: not seen (access to PCI IP Core Register Space)

MEMORY space : PCIH_BA1_SPACE + 0x72

Address from VME interface: A16 space: VME_SLVA + 0x72

A24 space: CR_CSR_BAR + BEG_USER_CSR + 0x72

Width: 8

Reset Value: 0x00

Access type: Read/Write

7	6	5	4	3	2	1	0
---	---	---	---	---	---	---	---

Bit(s)	Description
0 -7	VME_TIM_DTBTOUT[7:0] Time-out from 0 to 256 us for Data transfers on the VMEbus 0000 0000: Timer is inactive Others: Timer initial setting in microseconds.

VME_MST

VME Master Control register

Address from PCI interface: Config space: not seen (access to PCI IP Core Register Space)

MEMORY space : PCIH_BA1_SPACE + 0x73

Address from VME interface: A16 space: VME_SLVA + 0x73

A24 space: CR_CSR_BAR + BEG_USER_CSR + 0x73

Width: 8
Reset Value: 0x00
Access type: Read/Write

7	6	5	4	3	2	1	0
---	---	---	---	---	---	---	---

Bit(s)	Description
0	Reserved - RW
1	Reserved - RW
2	VME_MST_ABORT A BERR Acknowledgment on the VME bus is translated onto the PCI bus as a: 1: Normal acknowledgment 0: Target Abort
3	VME_MST_LECPERF (Recommended setting is 1) Controls the DTACK* handling latency on Master Reads and thus has an effect on the data transfer rate. 0: Normal handling of V_DTACKib assertion on Reads 1: Fast handling of V_DTACKib assertion on reads
4 - 5	VME_MST_VMEPERF[1:0] These 2 bits control latency between data phases on Master Writes (MASTER state machine) and thus has an effect on the data transfer rate. 00,01,11 : Normal latency between data phases on master Writes 10: Low latency between data phases on master Writes (Recommended setting is bits[29:28]= 10)
6 - 7	VME_MST_PCIPERF[1:0] (Recommended setting is bits[31:30]= 10. These 2 bits control latency between data phases on Master Writes (FIFO data routing latency) and thus has an effect on the data transfer rate. 00,01,11: Normal latency between data phases on master Writes 10: Low latency between data phases on master Writes

VME_SEM

VME Semaphore Register

Address from PCI interface: Config space: not seen (access to PCI IP Core Register Space)

MEMORY space : PCIH_BA1_SPACE + 0x48 & 74

Address from VME interface: A16 space: VME_SLVA + 0x48 & 74

A24 space: + 0x48 & 74

Width: 32

Reset Value: 0x00000000

Access type: Read/Write

VME_SEM [0:3]

31	30	29	28	27	26	25	24	23	22	21	20	19	18	17	16	15	14	13	12	11	10	9	8	7	6	5	4	3	2	1	0
----	----	----	----	----	----	----	----	----	----	----	----	----	----	----	----	----	----	----	----	----	----	---	---	---	---	---	---	---	---	---	---

Bit(s)	Description
7 - 0	VME_SEM0[7:0] Reset By POWER_ON_RESET
15 - 8	VME_SEM1[7:0] Reset By POWER_ON_RESET
23 - 16	VME_SEM2[7:0]
31 - 24	VME_SEM3[7:0]

VME Semaphore Registers

Four 8-bit Semaphore Registers are shared between PCI and VME, mapped at addresses 48 and 74.

These registers are conditionally written when address offsets 74, 75, 76 and 77 are accessed in write mode. They are unconditionally written when address offsets 48, 49, 4A and 4B are accessed in write mode.

Data is defined into the 7 low-order bits of the register while the high-order bit is used as a control bit which enables the register to be written. Multiple semaphore Bytes can be read and written simultaneously by using a 32-bit cycles to extend number of bits available; in this case, bit 7 of each Byte should be the same.

Semaphore write:

A write to address offsets 74 or 75 or 76 or 77 is executed when one of the following conditions are met:

- The register high-order bit is at 0 (semaphore not busy).
- The register high-order bit is at 1 (semaphore busy) with the high-order bit of the Data to be written at 0.

A write to address offsets 48 or 49 or 4A or 4B is unconditionally executed.

Semaphore Read:

Semaphore registers read is allowed under no conditions, however, they can be read only at address offset: 74, 75, 76 and 77.

Semaphore Register usage example:

- To get Semaphore ownership:
 - Loop on writing Semaphore registers a 7 bits unique task identifier with high order bit set to 1, until reading back the same value
- To release Semaphore ownership:
 - Write anything with the high order bit reset to zero (0x00 for example)

VME_SLVA

VME Slave Channel A Address Register

Address from PCI interface: Config space: not seen (access to PCI IP Core Register Space)

MEMORY space : PCIH_BA1_SPACE + 0x78

Address from VME interface: A16 space: VME_SLVA + 0x78

A24 space: CR_CSR_BAR + BEG_USER_CSR + 0x78

Width: 16

Reset Value: 0x0000

Access type: Read/Write

15	14	13	12	11	10	9	8	7	6	5	4	3	2	1	0
----	----	----	----	----	----	---	---	---	---	---	---	---	---	---	---

Bit(s)	Description
7 - 0	VME_SLVA_ADD[7:0] VME Slave Channel A Base address State on external pins VME_BASE_ADD[7:6], GAP, GAB[4:0] is sampled & loaded in this register on resets. Bit 7: VME_BASE_ADD7 Bit 6: VME_BASE_ADD6 Bit 5: GAP Bit 4:0: GAB[4:0]
15 -8	VME_SLVA_AM[7:0] VME Slave Channel A Address Modifier decoding bits (3/8 encoding of the AM2-AM0 code) AM2-AM0 code is decoded as valid if register bit=1; is decoded as invalid if register bit=0.

VME_SLV

VME Slave Control Register

Address from PCI interface: Config space: not seen (access to PCI IP Core Register Space)

MEMORY space : PCIH_BA1_SPACE + 0x7A

Address from VME interface: A16 space: VME_SLVA + 0x7A

A24 space: CR_CSR_BAR + BEG_USER_CSR + 0x7A

Width: 8

Reset Value: 0x00

Access type: Read/Write

7	6	5	4	3	2	1	0
---	---	---	---	---	---	---	---

Bit(s)	Description
0	VME_SLV_ABORT 0: On aborted PCI transaction, ALMA2f acknowledges the VME bus by signalling BERR* 1: On aborted PCI transaction, ALMA2f acknowledges the VME bus by signalling DTACK*
1	Reserved - RW VME_SLV_D64DBL 0: A VME MBLT read access, with Read prefetch mode disabled on PCI, is translated into a suite of PCI single 32-bit data accesses. 1: into a suite of PCI 2 data burst accesses.
2	VME_SLV_DTACKPERF This bit controls the DTACK* assertion timing on slave posted writes and thus has an effect on the data transfer rate. 0: normal assertion of V_DTACKob on Posted Writes 1: fast assertion of V_DTACKob on Posted Writes Recommended setting is 1.
3	VME_SLV_DTACK120PERF This bit controls the DTACK* assertion timing on slave reads and thus has an effect on the data transfer rate. 0: normal assertion of V_DTACKob on Reads 1: fast assertion of V_DTACKob on Reads Recommended setting is 1.
4	VME_SLV_DTACKMSKPERF This bit operates on the DTACK* de-assertion timing on slave writes and thus has an effect on the data transfer rate. 0: normal De-assertion of V_DTACKob on Writes 1: fast De-assertion of V_DTACKob on Writes Recommended setting is 1.
5	Reserved - Must be left to zero (otherwise ALMA2f behavior is unpredictable)
6	VME_CR_CSR_EN (was reserved in ALMA_V64) 0: only the "ALMA_V64" Registers can be accessed by the VME with type A16 AM (Address Modifiers). 1: All the ALMA2f's Registers can be accessed in mode CR/CSR (AM A24)
7	AUTO_SLOT_ID (was reserved in ALMA_V64) Reflect signal value of AUTO_SLOT_ID

Note: In debug mode it could be interesting to set the VME_SLV_ABORT bit at "1" to avoid a Bus error generated on the VME bus, which would result into an exception signaling on the board and a board reboot.

VME_PERF

VME Master Performance Control Register

Address from PCI interface: Config space: not seen (access to PCI IP Core Register Space)

MEMORY space : PCIH_BA1_SPACE + 0x7B

Address from VME interface: A16 space: VME_SLVA + 0x7B

A24 space: CR_CSR_BAR + BEG_USER_CSR + 0x7B

Width: 8
Reset Value: 0x00
Access type: Read/Write

7	6	5	4	3	2	1	0
---	---	---	---	---	---	---	---

Bit(s)	Description
0	VME_ARB_PERF This bit controls the number of clocks used to internally re synchronize the BGIN3-0* daisy-chains signals. 0: V_BGINb[3:0] input signals are re-synchronized with 2 clocks. 1: V_BGINb[3:0] input signals are re-synchronized with 1 clock. Recommended setting is 0
1	Reserved: Must be held to zero (otherwise ALMA2f behavior is unpredictable)
2	VME_MST_FIRSTPERF This bit controls AS* assertion timing on master writes and thus has an effect on the data transfer rate. 0: normal assertion of the first V_ASb on Writes 1: fast assertion of the first V_ASb on Writes Recommended setting is 1.
3	VME_MST_DS021PERF This bit controls DS1-0* de-assertion timing on master reads and thus has an effect on the data transfer rate. 0: normal de-assertion of V_DSb[1:0] on Reads 1: fast de-assertion of V_DSb[1:0] on Reads Recommended setting is 1.
4	VME_MST_DS120PERF This bit controls DS1-0* assertion timing on master writes and thus has an effect on the data transfer rate. 0: normal assertion of V_DSb[1:0] on Writes 1: fast assertion of V_DSb[1:0] on Writes Recommended setting is 1.
5 - 6	Reserved: Must be held to zero (otherwise ALMA2f behavior is unpredictable)
7	Reserved



VME_SLVA_LEBE

VME Slave Channel A Byte Ordering Control Registers

Address from PCI interface: Config space: not seen (access to PCI IP Core Register Space)

MEMORY space : PCIH_BA1_SPACE + 0x7C

Address from VME interface: A16 space: VME_SLVA + 0x7C

A24 space: CR_CSR_BAR + BEG_USER_CSR + 0x7C

Width: 8

Reset Value: 0x00

Access type: Read/Write

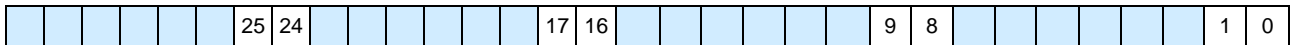

Bit(s)	Description
	Endian conversion performed when registers are accessed by the VME side: 00 mode «No Conversion» 01 mode «Address Coherency» 10 mode «Data Coherency» 11 mode «Bytes Translation with No Swapping»
1 - 0	Byte 0
9 - 8	Byte 1
17 - 16	Byte 2
25 - 24	Byte 3

The conversion mode should be the same in the 4 registers. If the two bits differs from register to register, the functionality is undefined.

VME_SLV0

VME Slave Channel 0 Control Register

Same definition for address offset 0x80 0x88 0x90 0x98 0xA0 0xA8 0xB0 0xB8

Address from PCI interface: Configuration space: 0x80

MEMORY space: PCIH_BA1_SPACE + 0x80

Address from VME interface: A16 space: VME_SLVA + 0x80

A24 space: CR_CSR_BAR + BEG_USER_CSR + 0x80

Width: 32

Reset Value: 0x00000000

Access type: Read/Write

VME_SLV0 (offset 0x80)

31	30	29	28	27	26	25	24	23	22	21	20	19	18	17	16	15	14	13	12	11	10	9	8	7	6	5	4	3	2	1	0
----	----	----	----	----	----	----	----	----	----	----	----	----	----	----	----	----	----	----	----	----	----	---	---	---	---	---	---	---	---	---	---

Bit(s)	Description
12 - 0	VME_SLV0/7_ADD[11:0] VME Slave Channel 0/7 base address The 12 bits of the incoming VME address A[31:21] are compared to the 12 bits of this register to validate the access on this channel (see also VME_SLV0/7_ADDMSK)
13 - 12	VME_SLV0/7_LEBE[1:0] Data byte ordering conversion mode performed on a VME access to PCI: 00 mode «No Conversion» 01 mode «Address Coherency» 10 mode «Data Coherency» 11 mode «Bytes Translation with No Swapping»
14	VME_SLV0/7_WPOST 1: Enables Write posting on this channel
15	VME_SLV0/7_RAHEAD 1: Enables Read prefetching on this channel
27 - 16	VME_SLV0/7_ADDMSK[11:0] 0: Address bits decoding is masked on that bit position, 1: Address bits decoding is enabled on that bit position (see VME_SLV0/7_ADD).
30 - 28	VME_SLV0/7_BUSCOM[2:0] PCI Bus Command[3:1] of the PCI cycle generated by ALMA2f
31	VME_SLV0/7_ENABLE Slave channel 0/7 enable (bit=1) / disable (bit=0)

VME_SLV0 (offset 0x84)

31	30	29	28	27	26	25	24	23	22	21	20	19	18	17	16	15	14	13	12	11	10	9	8	7	6	5	4	3	2	1	0
----	----	----	----	----	----	----	----	----	----	----	----	----	----	----	----	----	----	----	----	----	----	---	---	---	---	---	---	---	---	---	---

Bit(s)	Description
7 - 0	VME_SLV0/7_AM[7:0] (Valid if bit = 1) VME Slave Channel 0:7 Address Modifier decoding bits (3/8 encoding of the AM2-AM0 code)
15 - 8	VME_SLV0/7_AM[15:8] (Valid if bit = 1) VME Slave Channel 0:7 Address Modifier decoding bits (3/8 encoding of the AM5-AM3 code)
31 - 16	VME_SLV0/7_OFFSET[15:0] Address Translation to apply on bits 31-16 of the VME address for PCI address generation

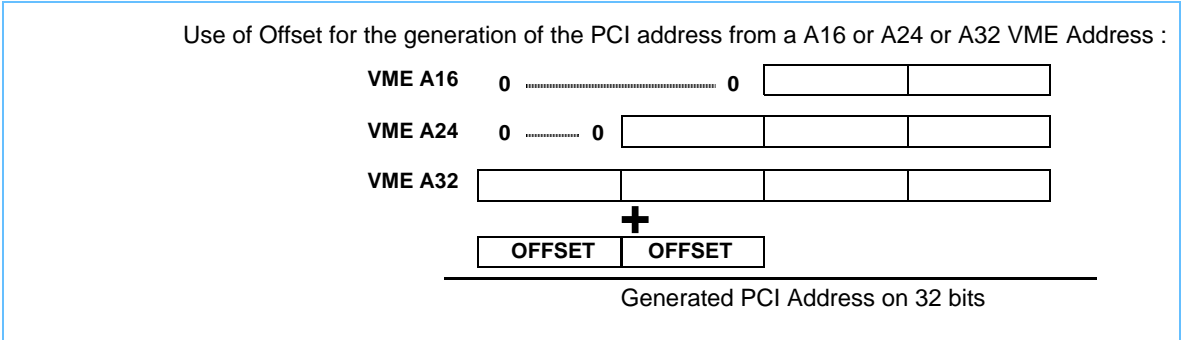

2.0.5 ALMA2f DMA Registers

Address	Size	Name	Use	Page	Notes
0xC0	4 bytes	DMA_CHN0_ADDVME	DMA Channel 0 VME Address	64	
0xC4	4 bytes	DMA_CHN0_ADDPCI	DMA Channel 0 PCI Address	64	
0xC8	3 bytes	DMA_CHN0_XFRSIZE	DMA Channel 0 transfer size	65	
0xCB	1 byte	DMA_CHN0_BLOCSIZE	DMA Channel 0 Block size	65	
0xCC	2 bytes	DMA_CHN0_CTRL	DMA Channel 0 Control	66	
0xCE	1 byte	DMA_CHN0_XAM	DMA Channel 0 Extended Address Modifier	67	
0xCF	1 byte	DMA_CHN0_RATE	DMA Channel 0 transfer Rate	68	
0xD0	4 bytes	DMA_CHN1_ADDVME	DMA Channel 1 VME Address	69	
0xD4	4 bytes	DMA_CHN1_ADDPCI	DMA Channel 1 PCI Address	69	
0xD8	3 bytes	DMA_CHN1_XFRSIZE	DMA Channel 1 transfer size	70	
0xDB	1 byte	DMA_CHN1_BLOCSIZE	DMA Channel 1 Block size	70	
0xDC	2 bytes	DMA_CHN1_CTRL	DMA Channel 1 Control	71	
0xDE	1 byte	DMA_CHN1_XAM	DMA Channel 1 Extended Address Modifier	72	
0xDF	1 byte	DMA_CHN1_RATE	DMA Channel 1 transfer Rate	72	

DMA_CHN0_ADDVME

DMA Channel 0 VME Address register

Address from PCI interface:Config space: 0xC0

MEMORY space: PCIH_BA1_SPACE + 0xC0

Address from VME interface:A16 space: VME_SLVA + 0xC0

A24 space: CR_CSR_BAR + BEG_USER_CSR + 0xC0

Width: 32

Reset Value: 0x00000000

Access type: Read/Write

DMA_CHN0_ADDVME

31	30	29	28	27	26	25	24	23	22	21	20	19	18	17	16	15	14	13	12	11	10	9	8	7	6	5	4	3	2	1	0
----	----	----	----	----	----	----	----	----	----	----	----	----	----	----	----	----	----	----	----	----	----	---	---	---	---	---	---	---	---	---	---

Bit(s)	Description
31 - 0	DMA_CHN0_ADDVME: VME starting address for DMA channel 0 <i>Note: At the end of each block size, the VME address of the next block size is loaded in this register.</i>

DMA_CHN0_ADDPCI

DMA Channel 0 PCI Address register

Address from PCI interface:Config space: 0xC4

MEMORY space: PCIH_BA1_SPACE + 0xC4

Address from VME interface:A16 space: VME_SLVA + 0xC4

A24 space: CR_CSR_BAR + BEG_USER_CSR + 0xC4

Width: 32

Reset Value: 0x00000000

Access type: Read/Write

DMA_CHN0_ADDPCI

31	30	29	28	27	26	25	24	23	22	21	20	19	18	17	16	15	14	13	12	11	10	9	8	7	6	5	4	3	2	1	0
----	----	----	----	----	----	----	----	----	----	----	----	----	----	----	----	----	----	----	----	----	----	---	---	---	---	---	---	---	---	---	---

Bit(s)	Description
31 - 0	DMA_CHN0_ADDPCI: PCI starting address for DMA channel 0 <i>Note: At the end of each block size, the PCI address of the next block size is loaded in this register.</i>

DMA_CHN0_XFERSIZE

DMA Channel 0 Transfer Size register

Address from PCI interface:Config space: 0xC8

MEMORY space: PCIH_BA1_SPACE + 0xC8

Address from VME interface:A16 space: VME_SLVA + 0xC8

A24 space: CR_CSR_BAR + BEG_USER_CSR + 0xC8

Width: 24

Reset Value: 0x000000

Access type: Read/Write

DMA_CHN0_XFERSIZE

				20	19	18	17	16	15	14	13	12	11	10	9	8	7	6	5	4	3	2	1	0
--	--	--	--	----	----	----	----	----	----	----	----	----	----	----	---	---	---	---	---	---	---	---	---	---

Bit(s)	Description
20 - 0	Total number of VME cycles minus 1 to be performed for a DMA channel 0 transfer. Up to 4 Million of cycles can be programmed, giving 512MB for D64 or 256 MB for D32 * For 2eSST this number must be odd 1,3,5.
23 - 21	Reserved, return zero when read.

DMA_CHN0_BLOCSIZE

DMA Channel 0 Block Size register

Address from PCI interface:Configuration space: 0xCB

MEMORY space: PCIH_BA1_SPACE + 0xCB

Address from VME interface:A16 space: VME_SLVA + 0xCB

A24 space: CR_CSR_BAR + BEG_USER_CSR + 0xCB

Width: 8

Reset Value: 0x00

Access type: Read/Write

DMA_CHN0_BLOCSIZE

7	6	5	4	3	2	1	0
---	---	---	---	---	---	---	---

Bit(s)	Description
7 - 0	DMA_CHN0_BLOCSIZE*: Total number* of VME cycles minus 1 to be performed for each block of a DMA channel 0 transfer. In one VME cycle, 4 Bytes are transferred in D32, 8 Bytes are transferred in D64 (MBLT) Each VME cycle is defined by a new DTACK active. A block size is defined by a VME Tenure (AS) and the Maximum must comply with the VME Norm. * For 2eSST this number must be odd 1,3,5..

DMA_CHN0_CTRL

DMA Channel 0 Control register

Address from PCI interface: Configuration space: 0xCC

MEMORY space: PCIH_BA1_SPACE + 0xCC

Address from VME interface: A16 space: VME_SLVA + 0xCC

A24 space: CR_CSR_BAR + BEG_USER_CSR + 0xCC

Width: 16

Reset Value: 0x0000

Access type: Read / Write

DMA_CHN0_CTRL

15	14	13	12	11	10	9	8	7	6	5	4	3	2	1	0
----	----	----	----	----	----	---	---	---	---	---	---	---	---	---	---

Bit(s)	Description
0	DMA_CHN0_START: Set to 0: No DMA channel 0 running. set to 1: DMA channel 0 starts.
1	DMA_CHN0_MIXAGE: set to 0: DMA channel 0 has to wait the end of DMA channel 1 before to start. set to 1: Blocks of both channel 0 and 1 can be interleaved.
2	DMA_CHN0_VME2PCI: DMA transfer direction on channel 0 set to 0: PCI read to VME write. set to 1: VME read to PCI write.
5 - 3	DMA_CHN0_BUSCOM: Three high order bits of the PCI "bus command"
6	DMA_CHN0_NOINCR: No Increment; This mode works only with AM type Single or BLT It does not work for MBLT or 2eSST set to 0: normal DMA. set to 1: all VME cycles start at the same address.
7	Reserved: Must be left to 0
13 - 8	DMA_CHN0_AM: VME Address Modifier for DMA channel 0.
15 - 14	DMA_CHN0_LEBE: Conversion type to perform on DMA channel 0. 00: mode "No conversion" 01: mode "Address Coherency" 10: mode "Data Coherency" 11: mode "Bytes Translation with No Swapping"

DMA_CHN0_XAM

DMA Channel 0 Extended Address Modifier register

Address from PCI interface: Configuration space: 0xCE

MEMORY space: PCIH_BA1_SPACE + 0xCE

Address from VME interface: A16 space: VME_SLVA + 0xCE

A24 space: CR_CSR_BAR + BEG_USER_CSR + 0xCE

Width: 8

Reset Value: 0x00

Access type: Read/Write

DMA_CHN0_XAM

7	6	5	4	3	2	1	0
---	---	---	---	---	---	---	---

New register in ALMA2f for 2eSST protocol. Was reserved in previous ALMA version

Bit(s)	Description
7 - 0	DMA_CHN0_XAM: VME 2eSST extended Address Modifier for DMA channel 0 0x11: A32/D64 2eSST 0x12: A64/D64 2eSST 0x21: A32/D64, Broadcast 2eSST 0x22: A64/D64, Broadcast 2eSST Note: - For A64 addressing (XAM = 0x12 or XAM = 0x22), the 32 upper bits are specified in register DMA0_VME_A64 at offset 0x128. - For Broadcast transfer (XAM = 0x21 or XAM = 0x22), the parameter Slave Select is specified in register DMA0_VME_SLVSEL at offset 0x12C.

DMA_CHN0_RATE

DMA Channel 0 Transfer Rate register

Address from PCI interface: Configuration space: 0xCF

MEMORY space: PCIH_BA1_SPACE + 0xCF

Address from VME interface: A16 space: VME_SLVA + 0xCF

A24 space: CR_CSR_BAR + BEG_USER_CSR + 0xCF

Width: 8

Reset Value: 0x00

Access type: Read/Write

DMA_CHN0_RATE

7	6	5	4	3	2	1	0
---	---	---	---	---	---	---	---

New register in ALMA2f for 2eSST protocol. Was reserved in previous ALMA_V64 version

Bit(s)	Description
3 - 0	DMA_CHN0_RATE: VME 2eSST Transfer Rate parameter for DMA channel 0 0x0: 160 MB/s rate 0x1: 267 Mb/s rate 0x2: 320 MB/s rate 0x3: 0xF Reserved
7 - 4	Reserved, Return zero when Read.

DMA_CHN1_ADDVME

DMA Channel 1 VME Address register

Address from PCI interface:Config space: 0xD0

MEMORY space: PCIH_BA1_SPACE + 0xD0

Address from VME interface:A16 space: VME_SLVA + 0xD0

A24 space: CR_CSR_BAR + BEG_USER_CSR + 0xD0

Width: 32

Reset Value: 0x00000000

Access type: Read/Write

DMA_CHN1_ADDVME

31	30	29	28	27	26	25	24	23	22	21	20	19	18	17	16	15	14	13	12	11	10	9	8	7	6	5	4	3	2	1	0
----	----	----	----	----	----	----	----	----	----	----	----	----	----	----	----	----	----	----	----	----	----	---	---	---	---	---	---	---	---	---	---

Bit(s)	Description
31 - 0	DMA_CHN1_ADDVME: VME starting address for DMA channel 1 <i>Note: At the end of each block size, the VME address of the next block size is loaded in this register.</i>

DMA_CHN1_ADDPCI

DMA Channel 1 PCI Address register

Address from PCI interface:Config space: 0xD4

MEMORY space: PCIH_BA1_SPACE + 0xD4

Address from VME interface:A16 space: VME_SLVA + 0xD4

A24 space: CR_CSR_BAR + BEG_USER_CSR + 0xD4

Width: 32

Reset Value: 0x00000000

Access type: Read/Write

DMA_CHN1_ADDPCI

31	30	29	28	27	26	25	24	23	22	21	20	19	18	17	16	15	14	13	12	11	10	9	8	7	6	5	4	3	2	1	0
----	----	----	----	----	----	----	----	----	----	----	----	----	----	----	----	----	----	----	----	----	----	---	---	---	---	---	---	---	---	---	---

Bit(s)	Description
31 - 0	DMA_CHN1_ADDPCI: PCI starting address for DMA channel 1 <i>Note: At the end of each block size, the PCI address of the next block size is loaded in this register.</i>

DMA_CHN1_XFERSIZE

DMA Channel 1 Transfer Size register

Address from PCI interface:Config space: 0xD8

MEMORY space: PCIH_BA1_SPACE + 0xD8

Address from VME interface:A16 space: VME_SLVA + 0xD8

A24 space: CR_CSR_BAR + BEG_USER_CSR + 0xD8

Width: 24

Reset Value: 0x000000

Access type: Read/Write

DMA_CHN1_XFERSIZE

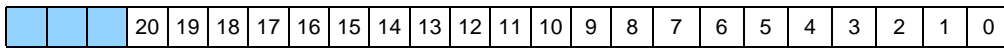

Bit(s)	Description
20 - 0	Total number of VME cycles to be performed for a DMA channel 1 transfer.
23 - 21	Reserved, return zero when read.

DMA_CHN1_BLOCSIZE

DMA Channel 1 Block Size register

Address from PCI interface:Configuration space: 0xDB

MEMORY space: PCIH_BA1_SPACE + 0xDB

Address from VME interface:A16 space: VME_SLVA + 0xDB

A24 space: CR_CSR_BAR + BEG_USER_CSR + 0xDB

Width: 8

Reset Value: 0x00

Access type: Read/Write

DMA_CHN1_BLOCSIZE

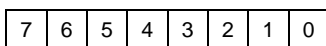

Bit(s)	Description
7 - 0	DMA_CHN1_BLOCSIZE: Total number of VME cycles to be performed for each of a DMA channel 1 transfer.

DMA_CHN1_CTRL

DMA Channel 1 Control register

Address from PCI interface: Configuration space: 0xDC

MEMORY space: PCIH_BA1_SPACE + 0xDC

Address from VME interface: A16 space: VME_SLVA + 0xDC

A24 space: CR_CSR_BAR + BEG_USER_CSR + 0xDC

Width: 16

Reset Value: 0x0000

Access type: Read / Write

DMA_CHN1_CTRL

15	14	13	12	11	10	9	8	7	6	5	4	3	2	1	0
----	----	----	----	----	----	---	---	---	---	---	---	---	---	---	---

Bit(s)	Description
0	DMA_CHN1_START: Set to 0: No DMA channel 0 running. set to 1: DMA channel 0 starts.
1	DMA_CHN1_MIXAGE: set to 0: DMA channel 1 has to wait the end of DMA channel 0 before to start. set to 1: Blocks of both channel 1 and 0 can be interleaved.
2	DMA_CHN1_VME2PCI: DMA transfer direction on channel 1 set to 0: PCI read to VME write. set to 1: VME read to PCI write.
5 - 3	DMA_CHN1_BUSCOM: Three high order bits of the PCI "bus command"
6	DMA_CHN1_NOINCR: No Increment; This mode works only with AM type Single or BLT It does not work for MBLT or 2eSST set to 0: normal DMA. set to 1: all VME cycles start at the same address.
7	Reserved - RW
13 - 8	DMA_CHN1_AM: VME Address Modifier for DMA channel 1
15 - 14	DMA_CHN1_LEBE: Conversion type to perform on DMA channel 1. 00: mode "No conversion" 01: mode "Address Coherency" 10: mode "Data Coherency" 11: mode "Bytes Translation with No Swapping"

DMA_CHN1_XAM

DMA Channel 1 Extended Address Modifier register

Address from PCI interface: Configuration space: 0xDE

MEMORY space: PCIH_BA1_SPACE + 0xDE

Address from VME interface: A16 space: VME_SLVA + 0xDE

A24 space: CR_CSR_BAR + BEG_USER_CSR + 0xDE

Width: 8

Reset Value: 0x00

Access type: Read/Write

7	6	5	4	3	2	1	0
---	---	---	---	---	---	---	---

New register in ALMA2f for 2eSST protocol. Was reserved in previous ALMA version

Bit(s)	Description
7 - 0	<p>DMA_CHN1_XAM: VME 2eSST extended Address Modifier for DMA channel 1</p> <p>0x11: A32/D64 2eSST 0x12: A64/D64 2eSST 0x21: A32/D64 Broadcast 2eSST 0x22: A64/D64 Broadcast 2eSST</p> <p>Note: For A64 addressing (XAM = 0x12 or XAM = 0x22), the 32 upper bits are specified in register DMA1_VME_A64 at offset 0x130. - For Broadcast transfer (XAM = 0x21 or XAM = 0x22), the parameter Slave Select is specified in register DMA1_VME_SLVSEL at offset 0x134.</p>

DMA_CHN1_RATE

DMA Channel 1 Transfer Rate register

Address from PCI interface: Configuration space: 0xDF

MEMORY space: PCIH_BA1_SPACE + 0xDF

Address from VME interface: A16 space: VME_SLVA + 0xDF

A24 space: CR_CSR_BAR + BEG_USER_CSR + 0xDF

Width: 8

Reset Value: 0x00

Access type: Read/Write

7	6	5	4	3	2	1	0
---	---	---	---	---	---	---	---

New register in ALMA2f for 2eSST protocol. Was reserved in previous ALMA version

Bit(s)	Description
3 - 0	<p>DMA_CHN1_RATE: VME 2eSST Transfer Rate parameter for DMA channel 1</p> <p>0x0: 160 MB/s rate 0x1: 267 Mb/s rate 0x2: 320 MB/s rate 0x3: 0xF Reserved</p>
7 - 4	Reserved, This bit is reserved and return zero when read.

2.0.6 ALMA2f Interrupt Operation Registers

The following Interrupt Registers are used for Interrupt control in ALMA2f.

The seven registers IT_ACKi are Virtual:

- A write access from the VME or the PCI bus to these registers has no effect
- A Read access from the VME bus to one of these registers resets it to 0.
- A Read access from the PCI bus to one of these registers results in an acknowledgment cycle of interrupt on the VME bus.

Address	Size	Name	Use	Page	Notes
0xE0	4 bytes	IT_INT_MSKSRC	Interrupt Source Mask Register	74	
0xE4	4 bytes	IT_INT_MSKOUT	PCI Interrupt Mask Register	75	
0xE8	4 bytes	IT_INT_STATUS	Interrupt Status Register	75	
0xEC	2 bytes	IT_INT_CTRL	PCI Interrupt Type Register	76	
0xEE	2 bytes	IT_ADD_SET RESET	Addressed Interrupt Register	77	
0xF0	4 bytes	IT_AVIT_ADD	AVIT VME cycle Address Register	78	
0xF4	1 bytes	IT_AVIT_CTRL	AVIT VME cycle Control Register	78	
0xF5	1 bytes	IT_AVIT_DATA	AVIT VME cycle Data Register	79	
0xF6	1 bytes	IT_AVIT_STA	AVIT Interrupt Status Register	79	
0xF7	1 bytes	IT_IRQ_VEC	VME IRQ* Vector Register	80	
0xF8	1 bytes	IT_IRQ_GEN	VME IRQ* Generation Register	80	
0xF9	7 bytes	IT_ACK1 to IT_ACK7	VME IACK Level 1 ... VME IACK Level 7 Registers	81	

IT_INT_MSKSRC

Interrupt Source Mask Register

This registers allows the masking of the sources of interrupt that can activate the P_INTAb output signal.

Address from PCI interface:Config space: not seen,
 MEMORY space: PCIH_BA1_SPACE + 0xE0

Address from VME interface:A16 space: not seen,
 A24 space: CR_CSR_BAR + BEG_USER_CSR + 0xE0

Width: 32

Reset Value: 0x00000000

Access type: Read/Write

31	30	29	28	27	26	25	24	23	22	21	20	19	18	17	16	15	14	13	12	11	10	9	8	7	6	5	4	3	2	1	0
----	----	----	----	----	----	----	----	----	----	----	----	----	----	----	----	----	----	----	----	----	----	---	---	---	---	---	---	---	---	---	---

bit=0: the corresponding interrupt source is not masked

bit=1: the corresponding interrupt source is masked

Bit(s)	Description
0	VME Bus Arbiter timeout (Edge detection)
5 - 1	Reserved
6	End of DMA Channel 1 (Edge detection)
7	End of DMA Channel 0 (Edge detection)
8	Exception VME & PCI (Edge detection) See definition in the CSR_USER_DEF_INT_MSKFAIL register at address 1E0
9	ALMA2f asserts BGLOCb pin (the PCI agent which requested the VME bus by asserting the BRLOCb pin, is granted) (Edge detection)
10	ALMA_2e deasserts BGLOCb pin (ALMA_2e is asking for the VME bus to be released) (Edge detection)
13 - 11	Reserved
14	SYSFAIL* (Level detection)
15	ACFAIL* (Level detection)
16	Addressed interrupt no 0 (Level detection)
17	Addressed interrupt no 1 (Level detection)
18	Addressed interrupt no 2 (Level detection)
19	Addressed interrupt no 3 (Level detection)
20	Addressed interrupt no 4 (Level detection)
21	Addressed interrupt no 5 (Level detection)
22	Addressed interrupt no 6 (Level detection)
23	Addressed interrupt no 7 (Level detection)
24	Reserved
25	VME IRQ1* (Level detection)
26	VME IRQ2* (Level detection)
27	VME IRQ3* (Level detection)
28	VME IRQ4* (Level detection)
29	VME IRQ5* (Level detection)
30	VME IRQ6* (Level detection)
31	VME IRQ7* (Level detection)

IT_INT_MSKOUT

PCI Interrupt Mask Register

Address from PCI interface:Config space: not seen,
MEMORY space: PCIH_BA1_SPACE + 0xE4

Address from VME interface:A16 space: not seen,
A24 space: CR_CSR_BAR + BEG_USER_CSR + 0xE4

Width: 32

Reset Value: 0x00000000

Access type: Read/Write

31	30	29	28	27	26	25	24	23	22	21	20	19	18	17	16	15	14	13	12	11	10	9	8	7	6	5	4	3	2	1	0
----	----	----	----	----	----	----	----	----	----	----	----	----	----	----	----	----	----	----	----	----	----	---	---	---	---	---	---	---	---	---	---

Bit(s)	Description
31 - 0	PCI INTERRUPT MASK: see above register IT_INT_MSKSRC[31:0] for interrupt source definition bit=0: the corresponding interrupt source generates an interrupt to the PCI bit=1: the corresponding interrupt source does not generates an interrupt to the PCI.

IT_INT_STATUS

Interrupt Status Register

Address from PCI interface:Config space: not seen,
MEMORY space: PCIH_BA1_SPACE + 0xE8

Address from VME interface:A16 space: not seen,
A24 space: CR_CSR_BAR + BEG_USER_CSR + 0xE8

Width: 32

Reset Value: 0x00000000

Access type: Read/Write

31	30	29	28	27	26	25	24	23	22	21	20	19	18	17	16	15	14	13	12	11	10	9	8	7	6	5	4	3	2	1	0
----	----	----	----	----	----	----	----	----	----	----	----	----	----	----	----	----	----	----	----	----	----	---	---	---	---	---	---	---	---	---	---

Bit(s)	Description
31 - 0	INTERRUPT SOURCE STATUS: see above register IT_INT_MSKSRC[31:0] for interrupt source definition bit=0: the corresponding interrupt source is inactive bit=1: the corresponding interrupt source is active.

IT_INT_CTRL

PCI Interrupt Type Register

Controls the assertion of Interrupt on outputs INT1b,2b,3b and P_INTAb

Address from PCI interface:Config space: not seen,
MEMORY space: PCIH_BA1_SPACE + 0xEC

Address from VME interface:A16 space: not seen,
A24 space: CR_CSR_BAR + BEG_USER_CSR + 0xEC

Width: 16

Reset Value: 0x0000

Access type: Read/Write

				12	11	10	9	8				5	4	3	2	1	0
--	--	--	--	----	----	----	---	---	--	--	--	---	---	---	---	---	---

Bit(s)	Description
2 - 0	IT_INT_INT1 INT1b Interrupt pin is asserted upon those interrupt sources among the seven VME IRQ*1 ... VME IRQ*7 selected by bits [2:0] encodings 001 to 111 respectively, (encoding 000 is Reserved).
5 - 3	IT_INT_INT2 INT2b Interrupt pin is asserted upon those interrupt sources among the seven VME IRQ*1 ... VME IRQ*7 selected by bits [5:3] encodings 001 to 111 respectively, (encoding 000 is Reserved).
7 - 6	Reserved
10 - 8	IT_INT_INT3 INT3b Interrupt pin is asserted upon activation of one interrupt sources among the 8 Addressed interrupt sources 0 to 7. The bits [10:8] are encoded from 000 to 111 such that only one Addressed interrupt can drive the INT3b signal. The Address interrupts are generated by writing a 1 to bit 7 to 0 of the IT_ADD_SET[7:0] Register.
11	IT_INT_MODE 0: P_INTAb pin (PCI INTA#) is asserted upon all interrupt sources, 1: INT1b, INT2b, INT3 pins are asserted upon those interrupt sources selected by IT_INT_INT1,2, 3 above register fields. P_INTAb pin (PCI INTA#) is asserted upon interrupt sources not selected by the above 3 register fields.
12	IT_INT_INT123_MODE if IT_INT_MODE = 1 this bit has no effect if IT_INT_MODE = 0 0: No interrupt asserted on pin INT1b,2b,3b 1: interrupt asserted on pin INT1b,2b,3b following the definition in registers CSR_USER_DEF_INT_MSKOUT1,2,3 and CSR_USER_DEF_INT_MSKFAIL Warning: The Read of this bit returns always a 0.
15-13	Reserved

IT_ADD_SET

Addressed Interrupt Register

Address from PCI interface: Config space: not seen,

MEMORY space: PCIH_BA1_SPACE + 0xEE

Address from VME interface: A16 space: not seen,

A24 space: CR_CSR_BAR + BEG_USER_CSR + 0xEE

Width: 32

Reset Value: 0x00000000

Access type: Read/Write

15	14	13	12	11	10	9	8	7	6	5	4	3	2	1	0
----	----	----	----	----	----	---	---	---	---	---	---	---	---	---	---

Bit(s)	Description
7 - 0	IT_ADD_SET[7:0] Write a "1" to bits [7:0] of this register sets active interrupt sources respectively to Addressed interrupt number 7 to 0.
15 - 8	IT_ADD_RESET[7:0] Write a "1" to bits [15:8] of this register deactivates interrupt sources respectively to Addressed interrupt number 7 to 0.

IT_AVIT_ADD

AVIT VME cycle Address Register

Address from PCI interface:Config space: not seen,
 MEMORY space: PCIH_BA1_SPACE + 0xF0

Address from VME interface:A16 space: not seen,
 A24 space: CR_CSR_BAR + BEG_USER_CSR + 0xF0

Width: 32
Reset Value: 0x00000000
Access type: Read/Write

31	30	29	28	27	26	25	24	23	22	21	20	19	18	17	16	15	14	13	12	11	10	9	8	7	6	5	4	3	2	1	0
----	----	----	----	----	----	----	----	----	----	----	----	----	----	----	----	----	----	----	----	----	----	---	---	---	---	---	---	---	---	---	---

Bit(s)	Description
31 - 0	IT_AVIT_ADD Address of the VME cycle generated upon PCI_AVITb pin assertion.

IT_AVIT_CTRL

AVIT VME cycle Control Register

Address from PCI interface:Config space: not seen,
 MEMORY space: PCIH_BA1_SPACE + 0xF4

Address from VME interface:A16 space: not seen,
 A24 space: CR_CSR_BAR + BEG_USER_CSR + 0xF4

Width: 8
Reset Value: 0x00
Access type: Read/Write

8	7	6	5	4	3	2	1	0
---	---	---	---	---	---	---	---	---

Bit(s)	Description
5 - 0	IT_AVIT_AM[5:0] Address Modifier of the VME cycle generated upon PCI_AVITb pin assertion.
6	IT_AVIT_WRITEB R/W mode of the VME cycle generated upon PCI_AVITb pin assertion. 0: Write 1: Read.
7	IT_AVIT_IRQSEL 0: a VME cycle is generated when upon assertion of PCI_AVITb pin. The Address, AM, R/W mode and Data of this cycle are supplied by the IT_AVIT_ADD, IT_AVIT_AM, IT_AVIT_WRITEB and IT_AVIT_DATA registers. The size of the VME transfer is a byte. 1: a VME Interrupt (IRQ7*...IRQ1*) is generated upon assertion of PCI_AVITb pin. Level of the interrupt is set equal to the rank of the set at 1 into IT_AVIT_DATA[7:1] register

IT_AVIT_DATA

AVIT VME cycle Data Register

Address from PCI interface:Config space: not seen,
MEMORY space: PCIH_BA1_SPACE + 0xF5

Address from VME interface:A16 space: not seen,
A24 space: CR_CSR_BAR + BEG_USER_CSR + 0xF5

Width: 8

Reset Value: 0x00

Access type: Read/Write

7	6	5	4	3	2	1	0
---	---	---	---	---	---	---	---

Bit(s)	Description
7 - 0	IT_AVIT_DATA[7:0] Write data value of the VME cycle generated upon PCI_AVITb pin assertion (case of IT_AVIT_IRQSEL=1). Interrupt level of the VME IRQ*7 ... VME IRQ*1 generated upon PCI_AVITb pin assertion (case of IT_AVIT_IRQSEL=0).

IT_AVIT_STA

AVIT Interrupt Status Register

Address from PCI interface:Config space: not seen,
MEMORY space: PCIH_BA1_SPACE + 0xF6

Address from VME interface:A16 space: not seen,
A24 space: CR_CSR_BAR + BEG_USER_CSR + 0xF6

Width: 8

Reset Value: 0x00

Access type: Read/Write

7	6	5	4	3	2	1	0
---	---	---	---	---	---	---	---

Bit(s)	Description
0	IT_AVIT_STATUS 0: PCI_AVITb pin function is Disabled. 1: PCI_AVITb pin function is Enabled. This bit is reset to 0, when the VME cycle or VME IRQ*7-1 generated by ALMA2f relatively to PCI_AVITb assertion, is acknowledged.

IT_IRQ_VEC

VME IRQ* Vector Register

Address from PCI interface:Config space: not seen,
MEMORY space: PCIH_BA1_SPACE + 0xF7

Address from VME interface:A16 space: not seen,
A24 space: CR_CSR_BAR + BEG_USER_CSR + 0xF7

Width: 8

Reset Value: 0x00

Access type: Read/Write

7	6	5	4	3	2	1	0
---	---	---	---	---	---	---	---

Bit(s)	Description
7 - 3	IT_IRQ_VEC[7:3] Five (5) most significant bits of the interrupt vector returned by ALMA2f in response to a VME interrupt acknowledge (IACK) cycle. The level of interrupt being returned is on the 3 least significant bits of the VME data byte lane.

IT_IRQ_GEN

VME IRQ* Generation Register

Address from PCI interface:Config space: not seen,
MEMORY space: PCIH_BA1_SPACE + 0xF8

Address from VME interface:A16 space: not seen,
A24 space: CR_CSR_BAR + BEG_USER_CSR + 0xF8

Width: 8

Reset Value: 0x00

Access type: Read/Write

7	6	5	4	3	2	1	0
---	---	---	---	---	---	---	---

Bit(s)	Description
0	IT_IRQ_GEN_ENABLE 1: interrupt generation feature is Enabled 0: interrupt generation feature is Disabled
7 - 1	IT_IRQ_GEN 1: VME IRQ*7-1 interrupt is (are) generated: 0: No interrupt is generated. ALMA2f asserts the V_IRQo[7:1] pins selected by those bit [7:1] at 1.

IT_ACK1 [2] [3] [4] [5] [6] [7]

VME IACK Level 1 ... VME IACK Level 7 Registers

When ALMA2f forwards a VME IRQ*7-1 interrupt to a PCI interrupt, the PCI Interrupt Handler issues then an interrupt acknowledge cycle as a read access to the one IT_ACK 8-bit register associated with the interrupt level.

ALMA2f translates that PCI read cycle into a VME IACK cycle, and the vector returned by the VME interruptor agent, is forwarded to the PCI bus as read data of the addressed IT_ACK register. The Seven IT_ACK[1..8] registers have the same definition.

Address from PCI interface:Config space: not seen,

MEMORY space: PCIH_BA1_SPACE + 0xF9

Address from VME interface:A16 space: not seen,

A24 space: CR_CSR_BAR + BEG_USER_CSR + 0xF9

Width: 8

Reset Value: 0x00

Access type: Read Only

7	6	5	4	3	2	1	0	IT_ACK1 Address 0xF9
7	6	5	4	3	2	1	0	IT_ACK2 Address 0xFA
7	6	5	4	3	2	1	0	IT_ACK3 Address 0xFB
7	6	5	4	3	2	1	0	IT_ACK4 Address 0xFC
7	6	5	4	3	2	1	0	IT_ACK5 Address 0xFD
7	6	5	4	3	2	1	0	IT_ACK6 Address 0xFE
7	6	5	4	3	2	1	0	IT_ACK7 Address 0xFF

Bit(s)	Description
7 - 0	IT_ACK1[7:0] Address 0xF9
7 - 0	IT_ACK2[7:0] Address 0xFA
7 - 0	IT_ACK3[7:0] Address 0xFB
7 - 0	IT_ACK4[7:0] Address 0xFC
7 - 0	IT_ACK5[7:0] Address 0xFD
7 - 0	IT_ACK6[7:0] Address 0xFE
7 - 0	IT_ACK7[7:0] Address 0xFF

2.0.7 ALMA2f Extended Registers

Address	Size	Name	Use	Page	Notes
0x100	4 bytes	DPT_CTL	Data path and FIFO control register	84	
0x104	4 bytes	VSR_CTL	VME Slave Read Control register	86	
0x108	4 bytes	DRP_CTL	DMA Read PCI Control register	87	
0x10C	4 bytes	PCR_CTL	PCI Read Control register	88	
0x110	4 bytes	PSR_CTL	PCI Slave Read Control register.	88	
0x114	4 bytes	DRV_CTL	DMA Read VME Control register	90	
0x118	4 bytes	VSW_CTL	VME Slave Write Control register	91	
0x11C	4 bytes	PSW_CTL	PCI Slave Write Control register	93	
0x120	4 bytes	VME_SLV_A64	VME Slave A64 upper bits Address	94	
0x124	4 bytes	VME_MST_A64	VME Master A64 upper bits Address	94	
0x128	4 bytes	DMA0_VME_A64	DMA Channel 0 A64 upper bits Address register	95	
0x12C	4 bytes	DMA0_VME_SLVSEL	DMA Channel 0 Slave Select register	95	
0x130	4 bytes	DMA1_VME_A64	DMA Channel 1 A64 upper bits Address register	96	
0x134	4 bytes	DMA1_VME_SLVSEL	DMA Channel 1 Slave Select register	96	
0x138	4 bytes	VME64_TCH	VME64x Trouble Shoot register	97	
0x13C	4 bytes		Reserved		
0x140	4 bytes	VME2ESST_CTL	VME 2eSST Control register	98	
0x180	4 bytes	CSR_USER_FUNC0_CTL	CSR user function 0 control register	100	
0x184	4 bytes	CSR_USER_FUNC0_A64	CSR user function 0 upper bits address register	101	
			CSR user function 1....6 control register		
			CSR user function 1....6 upper bits address register		
0x1B8	4 bytes	CSR_USER_FUNC7_CTL	CSR user function 7 control register		
0x1BC	4 bytes	CSR_USER_FUNC7_A64	CSR user function 7 upper bits address register		
0x1C0	4 bytes	CSR_USER_XRATE	Transfer Rate register	102	
0x1C8	8 bytes	CSR_USER_DEF_VME_TIME	VME Time register	102	
0x1D0	8 bytes	CSR_USER_DEF_VME_USED	Cumulative VME access Time register	103	
0x1D8	8 bytes	CSR_USER_DEF_ALMA_USED	Cumulative VME access Time to ALMA2f register	103	
0x1E0	4 bytes	CSR_USER_DEF_INT_MSKOUT1	Interrupt Mask register	104	
0x1E4	4 bytes	CSR_USER_DEF_INT_MSKOUT2			
0x1E8	4 bytes	CSR_USER_DEF_INT_MSKOUT3			
0x1EC	4 bytes	CSR_USER_DEF_INT_MSKFAIL	Interrupt Mask FAIL register	105	
0x1F0	1 bytes	GA	Geographical Address register	106	
0x1F1	1 bytes	CSR_USER_DEF_SUBUNIT_NB	Sub Unit Number register	106	
0x1F2	1 bytes	CSR_USER_DEF_RST_SRC	Reset Source register	107	
0x1F4	3 bytes	CSR_USER_DEF_REG0/1/2	General purpose register	107	
0x1F8					
0x1FC					

DPT_CTL

Data path and FIFO control register

Address from PCI interface: Config space: not seen,
 IO space: PCIH_BA1_SPACE + 0x100

Address from VME interface: A16 space: not seen,
 A24 space: CR_CSR_BAR + BEG_USER_CSR + 0x100

Width: 32

Reset Value: 0x00000000

Access type: Read/Write

Recommended value: 0x00108103 on a PCI 32 bit, 33 MHz bus
 0x00108133 on a PCI 64 bit, 33 MHz bus

31	30	29	28	27	26	25	24	23	22	21	20	19	18	17	16	15	14	13	12	11	10	9	8	7	6	5	4	3	2	1	0
Bit(s)		Description																													
0		Reserved - RW PCI FIFO is 2 KBytes PCI FIFO select (PCI write in PCI FIFO, VME Read PCI FIFO) set to 0:- 32 Bytes PCI FIFO selected set to 1:- 2 KBytes PCI FIFO selected It is Recommended to set bit 0 & 1 to the same value such that the VME and the PCI FIFOs are identical in size.																													
1		Reserved - RW VME FIFO is 2 KBytes VME FIFO select (VME write in VME FIFO, PCI Read VME FIFO) set to 0:- 32 bytes VME FIFO selected set to 1:- 2 KBytes VME FIFO selected																													
2		Must be left to 0																													
3		Reserved - RW																													
4		Reserved - RW PCI Master interface is PCI32 PCI 64 bit Master control set to 0:- PCI 64 bit Master interface Disable set to 1:- PCI 64 bit Master interface Enable Note: PCI 64 bit Master interface is enable only if both PCI FIFO select and VME FIFO select are set to 1.																													
5		Reserved - RW PCI Slave interface is PCI32 PCI 64 bit Slave control set to 0:- PCI 64 bit Slave interface is Disable set to 1:- PCI 64 bit Slave interface is Enable Note: PCI 64 bit Master interface is enable only if both PCI FIFO select and VME FIFO select are set to 1.																													
6		VME A64 MBLT control set to 0: VME A64 MBLT mode is Disable, ALMA2f interprets A64 AM as A32 AM code. set to 1: VME A64 MBLT mode is Enable.																													
7		VME A64 BLT and SGL control set to 0: VME A64 BLT and SGL mode is Disable, ALMA2f interprets A64 AM as A32 AM code. set to 1: VME A64 BLT and SGL mode is Enable.																													
8		VME Master Bloc size set to 0: VME bloc size is fixed and equal to 8 for PCI to VME access set to 1: VME bloc size is programmable. PCI to VME transfers for up to 2KBytes burst is controlled by the bit 0 of the PSW_CTL @ 11C set to 1 Note: this register does not control bloc size for DMA engine transfer.																													

9	<p>Reserved - RW PCI Slave interface is 66MHz</p> <p>PCI Frequency set to 0: Only PCI frequency at 33 MHz is supported (compatible with previous ALMA_V64 product) set to 1: PCI frequency up to 66 MHz is supported</p>
10	<p>Reserved - RW</p> <p>PCI Timing Control set to 0: Nominal timing control behavior set to 1: ALMA2e adds an extra PCI clock to detects that a PCI slave has accept PCI 64 transaction. In this case PCI slaves must not drive TRDY# on the same clock as DEVSEL#</p>
14 - 11	Reserved - RW
15	<p>DMA Fair Play mode set to 0: DMA fair play mode is Disable set to 1: DMA fair play mode is Enable</p>
31 - 16	<p>DMA Fair play period Represents the number of VME clock between two DMA requests when the DMA fair play mode is enable.</p>

VSR_CTL

VME Slave Read Control register

This register controls VME Slave Read access.

Address from PCI interface:Config space: not seen,
IO space: PCIH_BA1_SPACE + 0x104

Address from VME interface:A16 space: not seen,
A24 space: CR_CSR_BAR + BEG_USER_CSR + 0x104

Width: 32
Reset Value: 0x00000000
Access type: Read/Write

VSR_CTL

31	30	29	28	27	26	25	24	23	22	21	20	19	18	17	16	15	14	13	12	11	10	9	8	7	6	5	4	3	2	1	0
----	----	----	----	----	----	----	----	----	----	----	----	----	----	----	----	----	----	----	----	----	----	---	---	---	---	---	---	---	---	---	---

Bit(s)	Description
0	<p>Reserved. This bit is Read/Write and has no function</p> <p>Maximum PCI burst length on VME to PCI Read Ahead transaction is given by VSR_CTL[15:8]</p> <p>PCI read burst length control set to 0 the PCI burst length on VME to PCI read ahead transaction is fixed and equal to 32 Bytes. set to 1 the PCI burst length on VME to PCI read ahead transaction is programmable and given by VSR_CTL[15:8]</p>
1	<p>Reserved. This bit is Read/Write and has no function</p> <p>Maximum PCI burst length on VME 2eSST to PCI Read Ahead transaction is given by</p> <p>PCI read mode in VME 2eSST read transfer set to 0: The burst size of the PCI transaction is defined by other fields of this VSR_CTL register. set to 1: the PCI read burst is equal to the cycle count given by the VME 2eSST Read.</p>
2	<p>Read ahead mode option: set to 0: ALMA2e always gets a number of data equal to the PCI read burst size. set to 1: ALMA2e stops the PCI read burst as soon as ALMA2e detects the end of the read transaction on the VME bus.</p>
3 - 7	Reserved. These bits are read/write and have no functions
15 - 8	<p>PCI read burst size if VSR_CTL[0] is set to 1</p> <p>0x00: 32 bytes burst size 0x01: 64 bytes burst size 0x02: 128 bytes burst size 0x04: 256 bytes burst size 0x08: 512 bytes burst size 0x10: 1024 bytes burst size 0x20: 2048 bytes burst size Others values: 32 bytes burst size Note: ALMA2f does not control boundary crossing.</p>
31 - 16	Reserved. These bits are Read/Write and have no functions

Note:

**ALMA2e does not control boundary address crossing.
 The software must take care to avoid access to forbidden region due to read ahead.**

DRP_CTL

DMA Read PCI Control register

Address from PCI interface: Config space: not seen,
IO space: PCIH_BA1_SPACE + 0x108

Address from VME interface: A16 space: not seen,
A24 space: CR_CSR_BAR + BEG_USER_CSR + 0x108

Width: 32
Reset Value: 0x00000000
Access type: Read/Write
Recommended value: 0x00002003

DRP_CTL

31	30	29	28	27	26	25	24	23	22	21	20	19	18	17	16	15	14	13	12	11	10	9	8	7	6	5	4	3	2	1	0
----	----	----	----	----	----	----	----	----	----	----	----	----	----	----	----	----	----	----	----	----	----	---	---	---	---	---	---	---	---	---	---

Bit(s)	Description
31-0	Reserved - RW
0	Reserved - RW PCI burst length on PCI to VME DMA transaction is under PCI IP control PCI read burst length control set to 0- the PCI burst length on PCI to VME DMA transaction is fixed and equal to 32 bytes. set to 1- the PCI burst length on PCI to VME DMA transaction is programmable and given by DRP_CTL[15:8]
1	Reserved - RW PCI burst length on PCI to VME 2eSST DMA transaction is under PCI IP control PCI read mode in VME 2eSST read transfer set to 0- set to 1 the PCI read burst length is equal to the cycle count given by the VME 2esst DMA blocksize.
2 - 7	Reserved - RW
15 - 8	Reserved - RW PCI read burst length if DRP_CTL[0] is set to 1 -0x00:- 32 bytes burst size -0x01:- 64 bytes burst size -0x02:- 128 bytes burst size -0x04:- 256 bytes burst size -0x08:- 512 bytes burst size -0x10:- 1024 bytes burst size -0x20:- 2048 bytes burst size -Others values:- 32 bytes burst size Note: if the PCI burst length is greater than the DMA blocksize, ALMA2e generates a PCI burst size equal to the DMA burst size.
31 - 16	Reserved - RW

PCR_CTL

PCI Read Control register.

This register controls PCI read for VME to PCI read access and PCI to VME DMA.

Address from PCI interface:Config space: not seen,
IO space: PCIH_BA1_SPACE + 0x10C

Address from VME interface:A16 space: not seen,
A24 space: CR_CSR_BAR + BEG_USER_CSR + 0x10C

Width: 32
Reset Value: 0x00000000
Access type: Read/Write
Recommended value: 0x00000303

PCR_CTL

31	30	29	28	27	26	25	24	23	22	21	20	19	18	17	16	15	14	13	12	11	10	9	8	7	6	5	4	3	2	1	0
----	----	----	----	----	----	----	----	----	----	----	----	----	----	----	----	----	----	----	----	----	----	---	---	---	---	---	---	---	---	---	---

Bit(s)	Description
0	Reserved - RW ALMA2f waits until the PCI FIFO is empty before restarting a new PCI Read transfer PCI restart Read mode: set to 0- ALMA2e waits until the PCI FIFO is empty before restarting a new PCI Read transfer. set to 1- ALMA2e restarts a new PCI read transfer if the PCI FIFO hit the FIFO low level given in the register PCR_CTL[11:8]
1	Reserved - RW
2	Reserved - RW ALMA2f waits until the PCI FIFO is empty before restarting a new PCI Read transfer Read ahead mode option: set to 0- ALMA2e always gets a number of data equal to the PCI read burst size. set to 1- ALMA2e stops the PCI read burst as soon as ALMA2e detects that the transaction has already read 2,048 bytes. Must be left to 0.
7 - 3	Reserved - RW
11 - 8	Reserved - RW PCI Low level Value if PCR_CTL[0] is set to 1: -0x0- PCI FIFO empty -0x1- less than 16 Bytes left in PCI FIFO -0x2- less than 32 Bytes left in PCI FIFO -0x3- less than 48 Bytes left in PCI FIFO -0xn- less than 16 x n Bytes left in PCI FIFO -0xF- less than 256 Bytes left in PCI FIFO
31 - 12	Reserved - RW

Note: If register DPT_CTL[0] is set to 0 the register PCR_CTL[31:0] must be left to 0.

ALMA2f does not control boundary address crossing.
The software must take care to avoid access to forbidden region due to Read ahead.

PSR_CTL

PCI Slave Read Control register.

This register controls PCI to VME read transfers.

Address from PCI interface:Config space: not seen,
IO space: PCIH_BA1_SPACE + 0x110

Address from VME interface:A16 space: not seen,
A24 space: CR_CSR_BAR + BEG_USER_CSR + 0x110

Width: 32
Reset Value: 0x00000000
Access type: Read/Write
Recommended value: 0x00000000

PSR_CTL

31	30	29	28	27	26	25	24	23	22	21	20	19	18	17	16	15	14	13	12	11	10	9	8	7	6	5	4	3	2	1	0
----	----	----	----	----	----	----	----	----	----	----	----	----	----	----	----	----	----	----	----	----	----	---	---	---	---	---	---	---	---	---	---

Bit(s)	Description
0	VME Burst Size Control 0 : Burst Size is fixed to 512 words of 32 bits 1: Burst Size is indicated by PSR_CTL[14:8]
1	Reserved - RW Even for Single Read transfer, ALMA2e reads more than one data on the VME bus PCI Single read access control: set to 0, Even for Single Read transfer, ALMA2e reads more than one data on the VME bus. set to 1, when ALMA2e detects a PCI Single Read access, only one cycle Read is done on the VME bus. Warning: In MBLT mode, this may results in non-conform operation.
2 - 7	Reserved - RW
14 - 8	VME Burst Size generated for PCI read Access to VME Bus if PSR_CTL[0] is set to 1: 0x00: 32 Bytes burst size 0x01: 64 Bytes burst size 0x02: 128 Bytes burst size 0x04: 256 Bytes burst size 0x08: 512 Bytes burst size 0x10: 1024 Bytes burst size 0x20: 2048 Bytes burst size Others values: 32 Bytes burst size <i>Note: if VSW_CTL[0] is set to 1, this register as no effect.</i>
31-15	Reserved - RW

Note: If register DPT_CTL[0] is set to 0 register PCR_CTL[31:0] must be left to 0.

DRV_CTL

DMA Read VME Control register.

Address from PCI interface: Config space: not seen,
IO space: PCIH_BA1_SPACE + 0x114

Address from VME interface: A16 space: not seen,
A24 space: CR_CSR_BAR + BEG_USER_CSR + 0x114

Width: 32
Reset Value: 0x00000000
Access type: Read/Write

DRV_CTL

31	30	29	28	27	26	25	24	23	22	21	20	19	18	17	16	15	14	13	12	11	10	9	8	7	6	5	4	3	2	1	0
----	----	----	----	----	----	----	----	----	----	----	----	----	----	----	----	----	----	----	----	----	----	---	---	---	---	---	---	---	---	---	---

Bit(s)	Description
31-0	Reserved - RW
0	DMA read VME control: set to 0 ALMA2e is Unable to write in VME FIFO while the PCI reads the VME FIFO for DMA VME to PCI. set to 1 ALMA2e is Able to write in VME FIFO while the PCI reads the VME FIFO for DMA VME to PCI.
7-1	Reserved. This bits are read/write and have no functions
14-8	Burst size for DMA from VME to PCI 0x00: 32 Bytes 0x01: 64 Bytes 0x02: 96 Bytes 0x04: 256 Bytes 0x08: 512 Bytes 0x10: 1024 Bytes 0x20: 2078 Bytes others: 32 Bytes (8 word of 32 bits)
15	Reserved. This bit is reserved and return zero when read.
23-16	High Level of data in FIFO needed to start the PCI write transaction - DRV_CTL[0] is set to 1 0x0: 48 bytes 0x8: 176 bytes 0x1: 64 bytes 0x9: 192 bytes 0x2: 80 bytes 0xA: 208 bytes 0x3: 96 bytes 0xB: 224 bytes 0x4: 112 bytes 0xC: 240 bytes 0x5: 128 bytes 0xD: 256 bytes 0x6: 144 bytes 0xE: 272 bytes 0x7: 160 bytes 0xF: 288 bytes Note 1: if DRV_CTL[0] is set to 0, this register as no effect. Note 2: The High Level must be greater than the Low Level.
28-24	VME Low level of Data in FIFO under which the PCI write transaction is stopped. - DRV_CTL[0] is set to 1: 0x0: less than 16 bytes left in VME FIFO 0x1: less than 32 bytes left in VME FIFO 0x2: less than 48 bytes left in VME FIFO 0x3: less than 64 bytes left in VME FIFO 0xn: less than (n+1)x16 bytes left in VME FIFO 0xF: less than 256 bytes left in VME FIFO
31-29	Reserved. This bits are read/write and have no functions

Note: If register DPT_CTL[1] is set to 0 register DRV_CTL[31:0] must be left to 0.

VSW_CTL

VME Slave Write Control register.

This register controls VME to PCI write transaction.

Address from PCI interface: Config space: not seen,

IO space: PCIH_BA1_SPACE + 0x118

Address from VME interface: A16 space: not seen,

A24 space: CR_CSR_BAR + BEG_USER_CSR + 0x118

Width: 32

Reset Value: 0x00000000

Access type: Read/Write

Recommended value: 0x01030401

VSW_CTL

31	30	29	28	27	26	25	24	23	22	21	20	19	18	17	16	15	14	13	12	11	10	9	8	7	6	5	4	3	2	1	0
----	----	----	----	----	----	----	----	----	----	----	----	----	----	----	----	----	----	----	----	----	----	---	---	---	---	---	---	---	---	---	---

Bit(s)	Description
31-0	Reserved - RW
0	<p>VME Slave Write control: set to 0, ALMA2e is unable to write in VME FIFO while the PCI reads the VME FIFO for VME slave transaction. set to 1, ALMA2e is able to write in VME FIFO while the PCI reads the VME FIFO for VME slave transaction.</p>
7 - 1	Reserved. These bits are read/write and have no functions
14 - 8	<p>PCI write burst length if VSW_CTL[0] is set to 0</p> <ul style="list-style-type: none"> -0x00: 32 Bytes burst size -0x01: 64 Bytes burst size -0x02: 128 Bytes burst size -0x04: 256 Bytes burst size -0x08: 512 Bytes burst size -0x10: 1024 Bytes burst size -0x20: 2048 Bytes burst size -Others values: 32 Bytes burst size <p><i>Note: if VSW_CTL[0] is set to 1, this register as no effect.</i></p>
15	Reserved, This bit is reserved and return zero when read.
23 - 16	<p>High Level to start the PCI write transaction if VSW_CTL[0] is set to 1</p> <ul style="list-style-type: none"> -0x0: 48 bytes -0x1: 64 bytes -0x2: 80 bytes -0x3: 96 bytes -0x4: 112 bytes -0x5: 128 bytes -0x6: 144 bytes -0x7: 160 bytes -0x8: 176 bytes -0x9: 192 bytes -0xA: 208 bytes -0xB: 224 bytes -0xC: 240 bytes -0xD: 256 bytes -0xE: 272 bytes -0xF: 288 bytes <p><i>Note 1: if VSW_CTL[0] is set to 0, this register as no effect.</i> <i>Note 2: The High Level must be greater than the Low Level.</i></p>

27 - 24	<p>Low Level to start the PCI write transaction if VSW_CTL[0] is set to 1</p> <p>-0x0- 48 bytes left in VME FIFO</p> <p>-0x1- 64 bytes left in VME FIFO</p> <p>-0x2- 80 bytes left in VME FIFO</p> <p>-0x3- 96 bytes left in VME FIFO</p> <p>-0x4- 112 bytes left in VME FIFO</p> <p>-0x5- 128 bytes left in VME FIFO</p> <p>-0x6- 144 bytes left in VME FIFO</p> <p>-0x7- 160 bytes left in VME FIFO</p> <p>-0x8- 176 bytes left in VME FIFO</p> <p>-0x9- 192 bytes left in VME FIFO</p> <p>-0xA- 208 bytes left in VME FIFO</p> <p>-0xB- 224 bytes left in VME FIFO</p> <p>-0xC- 240 bytes left in VME FIFO</p> <p>-0xD- 256 bytes left in VME FIFO</p> <p>-0xE- 272 bytes left in VME FIFO</p> <p>-0xF- 288 bytes left in VME FIFO</p> <p>Note 1: if VSW_CTL[0] is set to 0, this register as no effect.</p> <p>Note 2: The Low Level must be less than the High Level</p>
31 - 28	Reserved. This bits are read/write and have no functions

Note 1: If register DPT_CTL[1] is set to 0 register DRV_CTL[31:0] must be left to 0.

Note 2: If the High Level and the Low level are to close, ALMA2e may miss the High Level value to restart the PCI transaction. The PCI transaction will then start at the end of the VME transaction. Performance will drop a little bit.

PSW_CTL

PCI Slave Write Control register.

This register controls PCI to VME write transaction.

Address from PCI interface:Config space: not seen,
IO space: PCIH_BA1_SPACE + 0x11C

Address from VME interface:A16 space: not seen,
A24 space: CR_CSR_BAR + BEG_USER_CSR + 0x11C

Width: 32
Reset Value: 0x00000000
Access type: Read/Write
Recommended value: 0x00000001

PSW_CTL

31	30	29	28	27	26	25	24	23	22	21	20	19	18	17	16	15	14	13	12	11	10	9	8	7	6	5	4	3	2	1	0
----	----	----	----	----	----	----	----	----	----	----	----	----	----	----	----	----	----	----	----	----	----	---	---	---	---	---	---	---	---	---	---

Bit(s)	Description
0	Reserved - RW ALMA2f accepts up to 2K bytes burst from PCI bus PCI Slave Write control: set to 0: ALMA2f generates a PCI Disconnect Without Data transfer on the ninth (9th) data. set to 1: ALMA2f accepts up to 2K bytes burst.
31 - 1	Reserved - RW

Note 1: ~~If register DPT_CTL[1] is set to 0 register DRV_CTL[31:0] must be left to 0.~~

VME_SLV_A64

VME Slave A64 Address register.

Address from PCI interface:Config space: not seen,
IO space: PCIH_BA1_SPACE + 0x120

Address from VME interface:A16 space: not seen,
A24 space: CR_CSR_BAR + BEG_USER_CSR + 0x120

Width: 32
Reset Value: 0x00000000
Access type: Read/Write

VME_SLV_A64

31	30	29	28	27	26	25	24	23	22	21	20	19	18	17	16	15	14	13	12	11	10	9	8	7	6	5	4	3	2	1	0
----	----	----	----	----	----	----	----	----	----	----	----	----	----	----	----	----	----	----	----	----	----	---	---	---	---	---	---	---	---	---	---

Bit(s)	Description
31 - 0	VME Slave Upper Address bits for A64 VME access

VME_MST_A64

VME Master A64 Address register.

Address from PCI interface:Config space: not seen,
IO space: PCIH_BA1_SPACE + 0x124

Address from VME interface:A16 space: not seen,
A24 space: CR_CSR_BAR + BEG_USER_CSR + 0x124

Width: 32
Reset Value: 0x00000000
Access type: Read/Write

VME_MST_A64

31	30	29	28	27	26	25	24	23	22	21	20	19	18	17	16	15	14	13	12	11	10	9	8	7	6	5	4	3	2	1	0
----	----	----	----	----	----	----	----	----	----	----	----	----	----	----	----	----	----	----	----	----	----	---	---	---	---	---	---	---	---	---	---

Bit(s)	Description
31 - 0	VME Master Upper Address bits for A64 VME access.

DMA0_VME_A64

DMA Channel 0 VME A64 upper bits Address register.

Address from PCI interface:Config space: not seen,
IO space: PCIH_BA1_SPACE + 0x128

Address from VME interface:A16 space: not seen,
A24 space: CR_CSR_BAR + BEG_USER_CSR + 0x128

Width: 32
Reset Value: 0x00000000
Access type: Read/Write

DMA0_VME_A64

31	30	29	28	27	26	25	24	23	22	21	20	19	18	17	16	15	14	13	12	11	10	9	8	7	6	5	4	3	2	1	0
----	----	----	----	----	----	----	----	----	----	----	----	----	----	----	----	----	----	----	----	----	----	---	---	---	---	---	---	---	---	---	---

Bit(s)	Description
31 - 0	DMA0_VME_A64: DMA Channel 0 VME Upper Address bits for A64 VME access.

DMA0_VME_SLVSEL

DMA Channel 0 VME Slave Select register.

Address from PCI interface:Config space: not seen,
IO space: PCIH_BA1_SPACE + 0x12C

Address from VME interface:A16 space: not seen,
A24 space: CR_CSR_BAR + BEG_USER_CSR + 0x12C

Width: 32
Reset Value: 0x00000000
Access type: Read/Write

DMA0_VME_SLVSEL

31	30	29	28	27	26	25	24	23	22	21	20	19	18	17	16	15	14	13	12	11	10	9	8	7	6	5	4	3	2	1	0
----	----	----	----	----	----	----	----	----	----	----	----	----	----	----	----	----	----	----	----	----	----	---	---	---	---	---	---	---	---	---	---

Bit(s)	Description
31 - 0	DMA0_VME_SLVSEL: DMA Channel 0 VME Slave Select signals for DMA channel 0 VME 2eSST broadcast cycles.

DMA1_VME_A64

DMA Channel 1 VME A64 upper bits Address register.

Address from PCI interface:Config space: not seen,
 IO space: PCIH_BA1_SPACE + 0x130
Address from VME interface:A16 space: not seen,
 A24 space: CR_CSR_BAR + BEG_USER_CSR + 0x130
Width: 32
Reset Value: 0x00000000
Access type: Read/Write

DMA1_VME_A64

31	30	29	28	27	26	25	24	23	22	21	20	19	18	17	16	15	14	13	12	11	10	9	8	7	6	5	4	3	2	1	0
----	----	----	----	----	----	----	----	----	----	----	----	----	----	----	----	----	----	----	----	----	----	---	---	---	---	---	---	---	---	---	---

Bit(s)	Description
31 - 0	DMA1_VME_A64: DMA Channel 1 VME Upper Address bits for A64 VME access.

DMA1_VME_SLVSEL

DMA Channel 1 VME Slave Select register.

Address from PCI interface:Config space: not seen,
 IO space: PCIH_BA1_SPACE + 0x134
Address from VME interface:A16 space: not seen,
 A24 space: CR_CSR_BAR + BEG_USER_CSR + 0x134
Width: 32
Reset Value: 0x00000000
Access type: Read/Write

DMA1_VME_SLVSEL

31	30	29	28	27	26	25	24	23	22	21	20	19	18	17	16	15	14	13	12	11	10	9	8	7	6	5	4	3	2	1	0
----	----	----	----	----	----	----	----	----	----	----	----	----	----	----	----	----	----	----	----	----	----	---	---	---	---	---	---	---	---	---	---

Bit(s)	Description
31 - 0	DMA1_VME_SLVSEL: DMA Channel 1 VME Slave Select signals for DMA channel 1 VME 2eSST broadcast cycles.

VME64_TCH

VME64x Trouble Shoot register.

This register is for debug purpose, must be set to 0x00000000

Address from PCI interface:Config space: not seen,
IO space: PCIH_BA1_SPACE + 0x138

Address from VME interface:A16 space: not seen,
A24 space: CR_CSR_BAR + BEG_USER_CSR + 0x138

Width: 32
Reset Value: 0x00000000
Access type: Read/Write
Recommended value: 0x00000000

VME64_TCH

31	30	29	28	27	26	25	24	23	22	21	20	19	18	17	16	15	14	13	12	11	10	9	8	7	6	5	4	3	2	1	0
----	----	----	----	----	----	----	----	----	----	----	----	----	----	----	----	----	----	----	----	----	----	---	---	---	---	---	---	---	---	---	---

Bit(s)	Description
31 - 0	ALMA_V64 design corrections For debug only. This register is used to activate corrective actions that prevents problems seen in previous revision of ALMA. Recommended setting is 0x0000 0000

VME2ESST_CTL

VME 2eSST Control register.

Address from PCI interface: Config space: not seen,
IO space: PCIH_BA1_SPACE + 0x140

Address from VME interface: A16 space: not seen,
A24 space: CR_CSR_BAR + BEG_USER_CSR + 0x140

Width: 32
Reset Value: 0x00002218
Access type: Read/Write

VME2ESST_CTL

31	30	29	28	27	26	25	24	23	22	21	20	19	18	17	16	15	14	13	12	11	10	9	8	7	6	5	4	3	2	1	0
----	----	----	----	----	----	----	----	----	----	----	----	----	----	----	----	----	----	----	----	----	----	---	---	---	---	---	---	---	---	---	---

Bit(s)	Description
0	V2ESST_SLV: VME 2eSST Slave mode enable set to 0: ALMA2f is unable to decode VME 2eSST transfer set to 1: ALMA2f is able to decode VME 2eSST transfer
1	V2ESST_MST: VME 2eSST Master mode enable set to 0: ALMA2f is unable to generate VME 2eSST transfer set to 1: ALMA2f is able to generate VME 2eSST transfer
2	V2ESST_BRD: VME 2eSST Broadcast mode enable set to 0: ALMA2f is unable to generate VME 2eSST Broadcast transfer set to 1: ALMA2f is able to generate VME 2eSST Broadcast transfer
3	VME320: Enable VME 320 Mbytes mode set to 0: ALMA2f will generate a Slave error during phase 3 of the address transfer of a VME 320 rate transfer, to signal to Master that it is unable to support 320 Mbytes transfer rate. set to 1: ALMA2f accepts all transfer rate as a Slave.
4	VME_SUSPEND set to 0: ALMA2f does not generate a Slave Suspend termination if the PCI interface is busy. set to 1: ALMA2f generate a Slave Suspend termination if the PCI interface is busy.
5 - 7	Reserved. These bits are read/write and have no functions
8 - 12	Speed Selection to generate data on the VME bus 0x1: Very Slow maximum transfer rate is 146 MB/s 0x2: Slow maximum transfer rate is 170.9 MB/s 0x4: Medium maximum transfer rate is 205 MB/s 0x8: Fast maximum transfer rate is 256 MB/s 0x10: Ultra Fast maximum transfer rate is 341 MB/s
13	Hold "H1" Timing: set to 0: the minimum time for timing H1 is equal to 0 ns, the 5ns required by the specification is ensure by the DTACK propagation delay. This register bit setting =0 is not recommended. Check your routing path before using this timing. set to 1: the minimum time for timing H1 is equal to 1 VME_CLK period (15.6 ns, the specification requires 5ns minimum).
14	S3 (2eSST) Setup Timing for the first data phase: Set to 0: Minimum time for S3 setup is equal to 1 VME_CLK period (15.6 ns) Set to 1: Minimum time for S3 setup is equal to 2 VME_CLK period (31.2 ns) <i>Note: Check the speed you want to run before setting this register.</i> Recommended setting =0 (Erratum #8 ALMA2e)
15	Reserved. This bit is Read/Write and has no function.
16	ODDBIT: This bit represents the value of the odd bit on VME 2eSST transfer.

17	DISABLE WRITE BACK: This feature is used only when ALMA2f generates a VME 2eSST DMA read (read VME and write PCI) and when the VME slave agent interrupts the VME transfer before the cycle count is reached. Set to 0: Write back is enable. (default value) ALMA2f will calculate the new DMA blocksize taking account of the less data on the previous cycle Set to 1: Write back is disable. The DMA engine does not check the number of data transfer, data will not be transferred
31 - 18	Reserved. This bits are read/write and have no functions

Note: If register DPT_CTL[0] or DPT_CTL[1] is set to 0
register VME2ESST_CTL[31:0] must be left to the reset value.

CSR_USER_FUNC0_CTL

CSR user function 0 control register (VME slave channel 9 control)

Address from PCI interface: Config space: not seen,
IO space: PCIH_BA1_SPACE + 0x180

Address from VME interface: A16 space: not seen,
A24 space: CR_CSR_BAR + BEG_USER_CSR + 0x180

Width: 32
Reset Value: 0x00000001
Access type: Read/Write

CSR_USER_FUNC0_CTL

31	30	29	28	27	26	25	24	23	22	21	20	19	18	17	16	15	14	13	12	11	10	9	8	7	6	5	4	3	2	1	0
----	----	----	----	----	----	----	----	----	----	----	----	----	----	----	----	----	----	----	----	----	----	---	---	---	---	---	---	---	---	---	---

Bit(s)	Description
1 - 0	Function 0 / Channel 9 LEBE Data byte ordering conversion mode performed on this channel 00: mode No Conversion 01: mode Address Coherency 10: mode Data Coherency 11: mode Byte translation with no swapping
2	Function 0 / Channel 9 WRITE POST set to 0: Write Post for this channel is disable set to 1: Write Post for this channel is enable
3	Function 0 / Channel 9 READ AHEAD set to 0: Read Ahead for this channel is disable set to 1: Read Ahead for this channel is enable
6 - 4	Function 0 / Channel 9 BUSCOM PCI Bus Command[3:1] of the PCI cycle generated by ALMA2f
7	Function 0 / Channel 9 Enable set to 0: the VME Function 0 / VME slave channel 9 is disable set to 1: the VME Function 0 / VME slave channel 9 is enable
31 - 8	OFFSET: Address translation Value to add to the VME address to obtain the PCI address. PCI address [31:0] = VME address [31:0] + OFFSET [31:8] **

The following CSR user function control registers have the same bit definition. They are at addresses;

- CSR_USER_FUNC1_CTL** at address 0x188
- CSR_USER_FUNC2_CTL** at address 0x190
- CSR_USER_FUNC3_CTL** at address 0x198
- CSR_USER_FUNC4_CTL** at address 0x1A0
- CSR_USER_FUNC5_CTL** at address 0x1A8
- CSR_USER_FUNC6_CTL** at address 0x1B0
- CSR_USER_FUNC7_CTL** at address 0x1B8

CSR_USER_FUNC0_A64

CSR user function 0 upper bits Address register. (VME slave channel 9 upper bits Address)

Address from PCI interface:Config space: not seen,

IO space: PCIH_BA1_SPACE + 0x184

Address from VME interface:A16 space: not seen,

A24 space: CR_CSR_BAR + BEG_USER_CSR + 0x184

Width: 32

Reset Value: 0x00000000

Access type: Read/Write

CSR_USER_FUNC0_A64

31	30	29	28	27	26	25	24	23	22	21	20	19	18	17	16	15	14	13	12	11	10	9	8	7	6	5	4	3	2	1	0
----	----	----	----	----	----	----	----	----	----	----	----	----	----	----	----	----	----	----	----	----	----	---	---	---	---	---	---	---	---	---	---

Bit(s)	Description
31 - 0	CSR_USER_FUNC0_A64: VME base address Upper bits for A64 VME access.

The following CSR user function Upper Bits Address registers have the same bit definition. They are at addresses;

CSR_USER_FUNC1_A64 at address 0x18C

CSR_USER_FUNC2_A64 at address 0x194

CSR_USER_FUNC3_A64 at address 0x19C

CSR_USER_FUNC4_A64 at address 0x1A4

CSR_USER_FUNC5_A64 at address 0x1AC

CSR_USER_FUNC6_A64 at address 0x1B4

CSR_USER_FUNC7_A64 at address 0x1BC

CSR_USER_DEF_VME_USED

CSR user function

Address from PCI interface:Config space: not seen,
IO space: PCIH_BA1_SPACE + 0x1D0

Address from VME interface:A16 space: not seen,
A24 space: CR_CSR_BAR + BEG_USER_CSR + 0x1D0

Width: 64
Reset Value: 0x00000000
Access type: Read/Write

CSR_USER_VME_USED

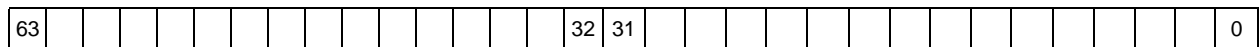

Bit(s)	Description
63 - 0	CSR_USER_VME_USED: Cumulative Time used on VME bus.

CSR_USER_DEF_ALMA_USED

CSR user function

Address from PCI interface:Config space: not seen,
IO space: PCIH_BA1_SPACE + 0x1D8

Address from VME interface:A16 space: not seen,
A24 space: CR_CSR_BAR + BEG_USER_CSR + 0x1D8

Width: 64
Reset Value: 0x00000000
Access type: Read/Write

CSR_USER_ALMA_USED

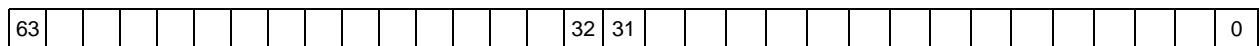

Bit(s)	Description
63 - 0	CSR_USER_ALMA_USED: Cumulative Time used on VME bus by ALMA2f.

CSR_USER_DEF_INT_MSKOUT1 2,3

Interrupt Mask Register

This register allows to Mask the interrupt source that can activate the INT1b output signal

Address from PCI interface:Config space: not seen,
IO space: PCIH_BA1_SPACE + 0x1E0

Address from VME interface:A16 space: not seen,
A24 space: CR_CSR_BAR + BEG_USER_CSR + 0x1E0

Width: 32

Reset Value: 0xFFFFFFFF

Access type: Read/Write

CSR_USER_DEF_INT_MSKOUT1

31	30	29	28	27	26	25	24	23	22	21	20	19	18	17	16	15	14	13	12	11	10	9	8	7	6	5	4	3	2	1	0
----	----	----	----	----	----	----	----	----	----	----	----	----	----	----	----	----	----	----	----	----	----	---	---	---	---	---	---	---	---	---	---

Bit(s)	Description
31	VME IRQ7 (Interrupt is masked if =1)
30	VME IRQ6
29	VME IRQ5
28	VME IRQ4
27	VME IRQ3
26	VME IRQ2
25	VME IRQ1
24	Reserved
23	Addressed Interrupt 7
22	Addressed Interrupt 6
21	Addressed Interrupt 5
20	Addressed Interrupt 4
19	Addressed Interrupt 3
18	Addressed Interrupt 2
17	Addressed Interrupt 1
16	Addressed Interrupt 0
15	ACFAIL
14	SYSFAIL
13 - 11	Reserved
10	ALMA2f deassert BGLOCb
9	ALMA2f assert BGLOCb
8	EXCEPTION VME & PCI See definition in the CSR_USER_DEF_INT_MSKFAIL register at address 1E0
7	End of DMA0
6	End of DMA1
5 - 1	Reserved
0	VME BUS Arbiter Time-out

The following registers have the same definition

CSR_USER_DEF_INT_MSKOUT2 at address 1E4 to mask source of interrupt to activate pin **INT2b**

CSR_USER_DEF_INT_MSKOUT3 at address 1E8 to mask source of interrupt to activate pin **INT3b**

GA

Geographical Address register

Address from PCI interface:Config space: not seen,
IO space: PCIH_BA1_SPACE + 0x1F0

Address from VME interface:A16 space: not seen,
A24 space: CR_CSR_BAR + BEG_USER_CSR + 0x1F0

Width: 8
Reset Value: GAb pins
Access type: Read Only

GA

7	6	5	4	3	2	1	0
---	---	---	---	---	---	---	---

Bit(s)	Description
4 - 0	GA: Geographical Address Read Only register, represents the value sample on GAb pins. <i>Note 1: this register is in positive logic, GAb pins are in negative logic.</i> <i>If ALMA2f is in VME slot 2 the GAb pins will be set at 0x1D, GA register will be set at 0x02.</i> Geographical parity value is not show in this register. <i>Note 2: This register value is used by the ALMA2f to check if an VME 2eSST access concerns it.</i>
7 - 5	Reserved, Return zero when read.

CSR_USER_DEF_SUBUNIT_NB

Sub Unit Number register

Address from PCI interface:Configuration space: 0x1F1
IO space: PCIH_BA1_SPACE + 0x1F1

Address from VME interface:A16 space: VME_SLVA + 0x1F1
A24 space: CR_CSR_BAR + BEG_USER_CSR + 0x1F1

Width: 8
Reset Value: 0x00
Access type: Read/Write

CSR_USER_DEF_SUBUNIT_NB

7	6	5	4	3	2	1	0
---	---	---	---	---	---	---	---

Bit(s)	Description
7 - 0	SUBUNIT_NB: Sub Unit Number to be transmitted in the 2eSST Protocol

CSR_USER_DEF_RST_SRC

Reset Source register

Address from PCI interface:Config space: not seen,
IO space: PCIH_BA1_SPACE + 0x1F2

Address from VME interface:A16 space: not seen,
A24 space: CR_CSR_BAR + BEG_USER_CSR + 0x1F2

Width: 8
Reset Value: 0x00
Access type: Read/Write

CSR_USER_DEF_RST_SRC

7	6	5	4	3	2	1	0
---	---	---	---	---	---	---	---

Bit(s)	Description
A Write to the bit (i) clears the bit (i)	
0	PWON: Reset source is Power On Reset
1	SYSRESET: Reset source is SYSRESETb signal
2	RESETIN: Reset source is RESETINb signal
3	ADD_RST: Reset source is an Addressed Reset
4	WD: Reset source is watchdog
7 - 5	Reserved

CSR_USER_DEF_REG0..1.2

General purpose register used for PCI/VME communication

Address from PCI interface:Config space: not seen,
IO space: PCIH_BA1_SPACE + 0x1F4

Address from VME interface:A16 space: not seen,
A24 space: CR_CSR_BAR + BEG_USER_CSR + 0x1F4

Width: 32
Reset Value: Indetermined
Access type: Read/Write

CSR_USER_DEF_REG0

31	30	29	28	27	26	25	24	23	22	21	20	19	18	17	16	15	14	13	12	11	10	9	8	7	6	5	4	3	2	1	0
----	----	----	----	----	----	----	----	----	----	----	----	----	----	----	----	----	----	----	----	----	----	---	---	---	---	---	---	---	---	---	---

Bit(s)	Description
31 - 0	User's Data

The two following 32 bit registers have the same definition as CSR_USER_DEF_REG0

CSR_USER_DEF_REG1 Address Offset 0x1F8

CSR_USER_DEF_REG2 Address Offset 0x1FC

2.0.8 Control/Status CSR Registers

The definition of the following control registers can be found in the VME64 EXTENSIONS - ANSI/VITA 1.1 1997 - Oct 7, 1998 specification Reference [2]

Address	Size	Name	Use	Page	Notes
0x7FFFF	1 bytes	CR CSR BAR	Base Address Register for CR_CSR registers	109	
0x7FFFB	1 bytes	BIT SET	BIT SET Register		
0x7FFF7	1 bytes	BIT CLEAR	BIT CLEAR Register		
0x7FFF3	1 bytes	CRAM OWNER	Configuration RAM OWNER Register		
0x7FFE7	1 bytes	USER DEF BIT SET	USER DEFINED BIT SET Register		
0x7FFEB	1 bytes	USER DEF BIT CLEAR	USER DEFINED BIT CLEAR Register		
0x7FFE3.. 0x7FFE7	2 bytes	RESERVED			
0x7FFD3.. 0x7FFDF	4 bytes	FUNCTION 7 ADER	Address Decode Compare Register 7	110	
0x7FFC3.. 0x7FFCF	4 bytes	FUNCTION 6 ADER	Address Decode Compare Register 6	110	
0x7FFB3.. 0x7FFBF	4 bytes	FUNCTION 5 ADER	Address Decode Compare Register 5	110	
0x7FFA3.. 0x7FFAF	4 bytes	FUNCTION 4 ADER4	Address Decode Compare Register 4	110	
0x7FF93.. 0x7FF9F	4 bytes	FUNCTION 3 ADER	Address Decode Compare Register 3	110	
0x7FF83.. 0x7FF8F	4 bytes	FUNCTION 2 ADER	Address Decode Compare Register 2	110	
0x7FF73.. 0x7FF7F	4 bytes	FUNCTION 1 ADER	Address Decode Compare Register 1	110	
0x7FF63.. 0x7FF6F	4 bytes	FUNCTION 0 ADER	Address Decode Compare Register 0	110	
0x7FC00.. 0x7FF5F	216 bytes	RESERVED	Registers Not implemented. Returns always 0 on Read		

CR_CSR_BAR

Base Address Register for CR_CSR registers

Address from PCI interface: Config space: not seen,

IO space: PCIH_BA1_SPACE + 0x80000 + 0x7FFFF

Address from VME interface: A16 space: not seen,

A24 space: CR_CSR_BAR + 0x7FFFF

Width: 8

Reset Value: 0x00000000

Access type: Read/Write

CR_CSR_BAR

7	6	5	4	3	2	1	0
---	---	---	---	---	---	---	---

Bit(s)	Description
7-0	CR_CSR_BAR Base Address for the 512KB CR_CSR space.

Function 7_ADER

Address Decode Compare 7 Register

Address from PCI interface:Config space: not seen,
IO space: 0x7FFD3

Address from VME interface:A16 space: not seen,
A24 space: 0x7FFD3

Width: 32
Reset Value: 0x00000000
Access type: Read/Write

Function 7_ADER

31	30	29	28	27	26	25	24	23	22	21	20	19	18	17	16	15	14	13	12	11	10	9	8	7	6	5	4	3	2	1	0
----	----	----	----	----	----	----	----	----	----	----	----	----	----	----	----	----	----	----	----	----	----	---	---	---	---	---	---	---	---	---	---

Bit(s)	Description
0	XAM
1	DFSR
7 - 2	AM[5:0] or XAM[5:0]
9 - 8	C[9:8] or XAM[7:6]
15 - 10	C[15:10] Compare bits 15-10
23 - 16	C[23:16] Compare bits 23-16
31 - 21	C[31:24] Compare bits 31-24

The following registers in addition with FUNCTION 7 ADER, defines up to 8 VME channels. They have the same definition.

FUNCTION 6 ADER	Address Decode Compare 6	address 0x7FFC3,
FUNCTION 5 ADER	Address Decode Compare 5	address 0x7FFB3,
FUNCTION 4 ADER	Address Decode Compare 4	address 0x7FFA3,
FUNCTION 3 ADER	Address Decode Compare 3	address 0x7FF93,
FUNCTION 2 ADER	Address Decode Compare 2	address 0x7FF83,
FUNCTION 1 ADER	Address Decode Compare 1	address 0x7FF73,
FUNCTION 0 ADER	Address Decode Compare 0	address 0x7FF63,

2.0.9 Configuration ROM (CR) Register

Following is the set of registers that are defined in the CR Configuration ROM space. These registers are R/W, implemented in ALMA2f and the user has the flexibility to define it, according to the VME64 Extension Norm. See reference [2] A read at a Reserved address returns always a Zero.

Address MSB..LSB	Designation	Size	Address MSB..LSB	Designation	Size
03	CHECKSUM	1 Byte	123.. 13F	FUNCTION 0 AM Code Mask	8 Byte
07, 0B, 0F	LENGTH of ROM	3 Byte	143.. 15F	FUNCTION 1 AM Code Mask	8 Byte
13	Config ROM data access width	1 Byte	163.. 17F	FUNCTION 2 AM Code Mask	8 Byte
17	CSR data access width	1 Byte	183.. 19F	FUNCTION 3 AM Code Mask	8 Byte
1B	CR CSR space Specification ID	1 Byte	1A3.. 1BF	FUNCTION 4 AM Code Mask	8 Byte
1F	ASCII "C"	1 Byte	1C3.. 1DF	FUNCTION 5 AM Code Mask	8 Byte
23	ASCII "R"	1 Byte	1E3.. 1FF	FUNCTION 6 AM Code Mask	8 Byte
27, 2B, 2F	Manufacturer's ID	3 Byte	203.. 21F	FUNCTION 7 AM Code Mask	8 Byte
33, 37, 3B, 3F	Board ID	4 Byte	223.. 29F	FUNCTION 0 XAM Code Mask	32Byte
43, 47, 4B, 4F	Revision ID	4 Byte	2A3.. 31F	FUNCTION 1 XAM Code Mask	32Byte
53, 57, 5B	0x000000	3 Byte	323.. 39F	FUNCTION 2 XAM Code Mask	32Byte
5F..7B	RESERVED	8 Byte	3A3.. 41F	FUNCTION 3 XAM Code Mask	32Byte
7F	Program ID Code	1 Byte	423.. 49F	FUNCTION 4 XAM Code Mask	32Byte
83, 87, 8B	Offset BEG USER CR	3 Byte	4A3.. 51F	FUNCTION 5 XAM Code Mask	32Byte
D7, DB, DF	Offset END SN	3 Byte	523.. 59F	FUNCTION 6 XAM Code Mask	32Byte
8F, 93, 97	Offset END USER CR	3 Byte	5A3.. 61F	FUNCTION 7 XAM Code Mask	32Byte
9B, 9F, A3	Offset BEG CRAM	3 Byte	623.. 62F	FUNCTION 0 Address Decoder Mask	4 Byte
A7, AB, AF	Offset END RAM	3 Byte	633.. 63F	FUNCTION 1 Add Deco Mask	4 Byte
B3, B7, BB	Offset BEG USER CSR	3 Byte	643.. 64F	FUNCTION 2 Add Deco Mask	4 Byte
BF, C3, C7	Offset END USER CSR	3 Byte	653.. 65F	FUNCTION 3 Add Deco Mask	4 Byte
CB, CF, D3	Offset BEG SN	3 Byte	663.. 66F	FUNCTION 4 Add Deco Mask	4 Byte
D7, DB, DF	Offset END SN	3 Byte	673.. 67F	FUNCTION 5 Add Deco Mask	4 Byte
E3	Slave Characteristics Parameters	1 Byte	683.. 68F	FUNCTION 6 Add Deco Mask	4 Byte
E7	USER DEF Slave Characteristics Parameters	1 Byte	693.. 69F	FUNCTION 7 Add Deco Mask	4 Byte
EB	Master Characteristics Parameter	1 Byte	6A3	RESERVED	1 Byte
EF	USER DEF Master Characteristics Param	1 Byte	6A7	RESERVED	1 Byte
F3	Interrupt Handler Capabilities	1 Byte	6AB	RESERVED	1 Byte
F7	Interrupt Capabilities	1 Byte	6AF	Master Data Access Width	1 Byte
FB	RESERVED	1 Byte	6B3.. 6CF	Master Data AM Capabilities	8 Byte
FF	CRAM Access Width	1 Byte	6D3.. 74F	Master Data XAM Capabilities	32Byte
103	FUNCTION 0 Access Width	1 Byte	753.. FFF	RESERVED	555 bytes
107	FUNCTION 1 Access Width	1 Byte			
10B	FUNCTION 2 Access Width	1 Byte			
10F	FUNCTION 3 Access Width	1 Byte			
113	FUNCTION 4 Access Width	1 Byte			
117	FUNCTION 5 Access Width	1 Byte			
11B	FUNCTION 6 Access Width	1 Byte			
11F	FUNCTION 7 Access Width	1 Byte			

Configuration ROM (CR) Registers details

Address	Size	Name	Use	Page	Notes
0x03	1 bytes	CHECKSUM			
B3, B7, BB	3 bytes	Offset BEG USER CSR	Begin Address of User CSR space	114	
BF, C3, C7	3 bytes	Offset END USER CSR			
0x620	3 bytes	ADEM_0_B03R	Read value of ADEM 0 byte 3	115	
0x623	1 bytes	ADEM_0_B03	ADEM 0 byte 3	115	
0x624	3 bytes	ADEM_0_B02R	Read value of ADEM 0 byte 2	116	
0x627	1 bytes	ADEM_0_B02	ADEM 0 byte 2	116	
0x628	3 bytes	ADEM_0_B01R	Read value of ADEM 0 byte 1	116	
0x62b	1 bytes	ADEM_0_B01	ADEM 0 byte 1	116	
0x62c	3 bytes	ADEM_0_B00R	Read value of ADEM 0 byte 0	117	
0x62f	1 bytes	ADEM_0_B00	ADEM 0 byte 0	117	

BEG_USER_CSR

Offset Address for access of the CR_CSR Registers

The 24 bits are split in 3 registers.

Address from PCI interface: Config space: not seen,
IO space: PCIH_BA1_SPACE + 80000 + 0xB3

Address from VME interface: A16 space: not seen,
A24 space: CR_CSR_BAR + 0xB3

Width: 24
Reset Value: 0x00
Access type: Read/Write

BEG_USER_CSR

7	6	5	4	3	2	1	0	0xB3
7	6	5	4	3	2	1	0	0xB7
7	6	5	4	3	2	1	0	0xBB

Bit(s)	Description
7 - 0	BEG_USER_CSR [7:0] Bits 7:0 at address 0xB3
15:8	BEG_USER_CSR [15:8] Bits 7:0 at address 0xB7
23:16	BEG_USER_CSR [23:16] Bits 7:0 at address 0xBB

ADEM_0_B03

ADEM byte 3, Address Decoder Mask Byte 3

Address from PCI interface:Config space: not seen,
IO space: PCIH_BA1_SPACE + 80000 + 0x620

Address from VME interface:A16 space: not seen,
A24 space: CR_CSR_BAR + 0x620

Width: 32
Reset Value: 0x00000000
Access type: Read/Write

ADEM_0_B03

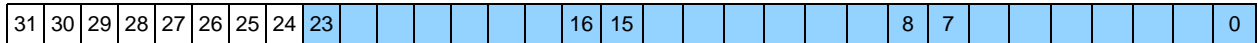

Bit(s)	Description
23 - 0	Read Only, (No effect on Write) A read to this register returns 3 times the VME Address Mask bits 31 - 24
31 - 24	VME Address Mask bits 31 - 24

The **FUNCTION 0 Address Decoder Mask (ADEM)** register includes the following registers defined hereafter.

- ADEM_0_B03** at address 0x620
- ADEM_0_B02** at address 0x624
- ADEM_0_B01** at address 0x628
- ADEM_0_B00** at address 0x62C

The following **FUNCTION # Address Decoder Mask (ADEM)** registers have the same bit definition. They are at offset addresses;

- FUNCTION 1 ADEM** at address 0x630
- FUNCTION 2 ADEM** at address 0x640
- FUNCTION 3 ADEM** at address 0x650
- FUNCTION 4 ADEM** at address 0x660
- FUNCTION 5 ADEM** at address 0x670
- FUNCTION 6 ADEM** at address 0x680
- FUNCTION 7 ADEM** at address 0x690

ADEM_0_B02

ADEM byte 2, Address Decoder Mask Byte 2

Address from PCI interface:Config space: not seen,
IO space: PCIH_BA1_SPACE + 80000 + 0x624

Address from VME interface:A16 space: not seen,
A24 space: CR_CSR_BAR + 0x624

Width: 32
Reset Value: 0x00000000
Access type: Read/Write

ADEM_0_B02

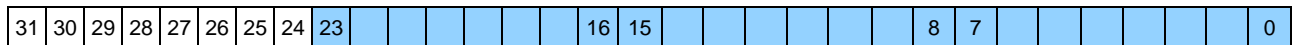

Bit(s)	Description
23 - 0	Read Only, (No effect on write) A read to this register returns 3 times the VME Address Mask bits 23 - 16
31 - 24	VME Address Mask bits 23 - 16

ADEM_0_B01

ADEM byte 1, Address Decoder Mask Byte 1

Address from PCI interface:Config space: not seen,
IO space: PCIH_BA1_SPACE + 80000 + 0x628

Address from VME interface:A16 space: not seen,
A24 space: CR_CSR_BAR + 0x628

Width: 32
Reset Value: 0x00000000
Access type: Read/Write

ADEM_0_B01

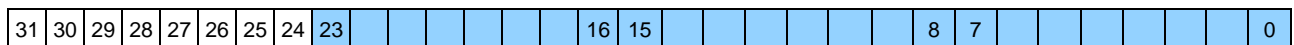

Bit(s)	Description
23 - 0	Read Only, (No effect on write) A read to this register returns 3 times the VME Address Mask bits 15 - 8
31 - 24	VME Address Mask bits 15 - 8

ADEM_0_B00

ADEM byte 0, Address Decoder Mask Byte 0

Address from PCI interface: Config space: not seen,
IO space: PCIH_BA1_SPACE + 80000 + 0x62C

Address from VME interface: A16 space: not seen,
A24 space: CR_CSR_BAR + 0x62C

Width: 32
Reset Value: 0x00000000
Access type: Read/Write

ADEM_0_B00

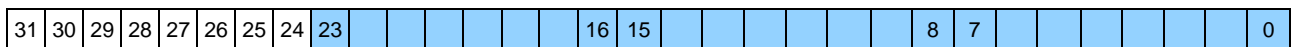

Bit(s)	Description
23 - 0	Read Only, (No effect on write) A read to this register returns 3 times the above Byte 3 of ADEM_0_B00
24	EFM: Extra function mask, this feature is not used in ALMA2f.
25	EFD: Extra function decoder 1: the next ADEM provides another decoder for the same function rather than another function.
26	DFS: Dynamic Function Sizing 1: the mask bits above are not valid because the function's size is dynamic.
27	FAF: Fixed Address function, 1: the function's ADER is not programmable.
31 - 28	Reserved, These bits are reserved and return zeros when read.

2.0.10 PCI IP Core Registers

These registers are **accessible from the PCI Interface only using CONFIGURATION Cycles**.

Address	Size	Name	Use	Page	Notes
0x44	4 bytes	PLDA_CORE_STATUS	PLDA Core Status Register	25	
0x48-0x4C	8 bytes	PCI-X CAPABILITIES	Reserved	25	
0x50-0x5C	16 bytes	MSI REGISTERS	Reserved	26	
0x60	4 bytes	PLDA_FLASH_CTRL	Reserved	27	
0x64	4byte	COMPACTPCI_HOTSWAP	Reserved	28	
0x68-0x74	16 bytes	CARDBUS_STATUS	Reserved	28	
0x78-0x7C	8 byte	POWER_MANAGEMENT	Reserved	28	

PLDA_CORE_STATUS

PLDA Core Status Register

This register provides helpful information about the core and also makes it possible to control a JTAG interface in order to perform in-site programming.

Address from PCI interface: Config space: not seen,

IO space: PCIH_BA1_SPACE + 0x1EC

Address from VME interface: A16 space: not seen,

A24 space: CR_CSR_BAR + BEG_USER_CSR + 0x1E0

Width: 32

Reset Value: 0x00000000

Access type: Read Only

CSR_USER_DEF_INT_MSKFAIL

31	30	29	28	27	26	25	24	23	22	21	20	19	18	17	16	15	14	13	12	11	10	9	8	7	6	5	4	3	2	1	0
----	----	----	----	----	----	----	----	----	----	----	----	----	----	----	----	----	----	----	----	----	----	---	---	---	---	---	---	---	---	---	---

Bit(s)	Description
31	Reserved
30	Bus mode 0 - Bus is in PCI mode 1 - Bus is in PCI-X mode
29-28	Bus speed This flag indicates bus speed : 0x00 : 33 MHz 0x01 : 66 MHz 0x10 : 100 MHz 0x11 : 133 MHz
27 - 16	Core version Identifies core release, for instance 0x100 means version 1.0.0
15-4	PLDA signature 0x614 identifies a PCI-only core 0x615 identifies a PCI-X capable core
3-0	Reserved

Chapter 3. SIGNAL DESCRIPTIONS

Signal notational conventions

- **b** - symbol at the end of a signal name denotes that the active state occurs when the signal is at the low voltage. When no «b» symbol is present, the signal is active high.
- **i** - Input signal (notation used when a VME standard bidirectional signal defines input and output signals)
- **o** - Output signal (notation used when a VME standard bidirectional signal defines input and output signals)

Signal Type Definition

The following signal type definitions are taken from Revision 2.2 of the PCI local bus specification.

- t/s** *Tri-State*[®] is a bidirectional, tri-state input/output pin
- s/t/s** *Sustained Tri-State* is an active low tri-state signal owned and driven by one and only one agent at a time. The agent that drives an s/t/s pin low must drive it high for at least one clock before letting it float. A new agent cannot start driving a s/t/s signal any sooner than one clock after the previous owner tri-states it. A pull-up is required to sustain the inactive state until another agent drives it, and must be provided by the central resource.
- o/d** *Open Drain* allows multiple devices to share as a wire-OR

All non mentioned output signal types are *Totem Pole* standard active driver
All inputs are TTL levels

5V Interface

All I/Os have protection circuitry that permits connection to 5 V busses without damage. This does not imply however, that the I/Os can actively drive CMOS-compatible 5V level.
TTL, LVTTTL, and PCI levels are only supported.

Pull-Down

All Pull-Down resistors must be lower or equal to 3KOhm.

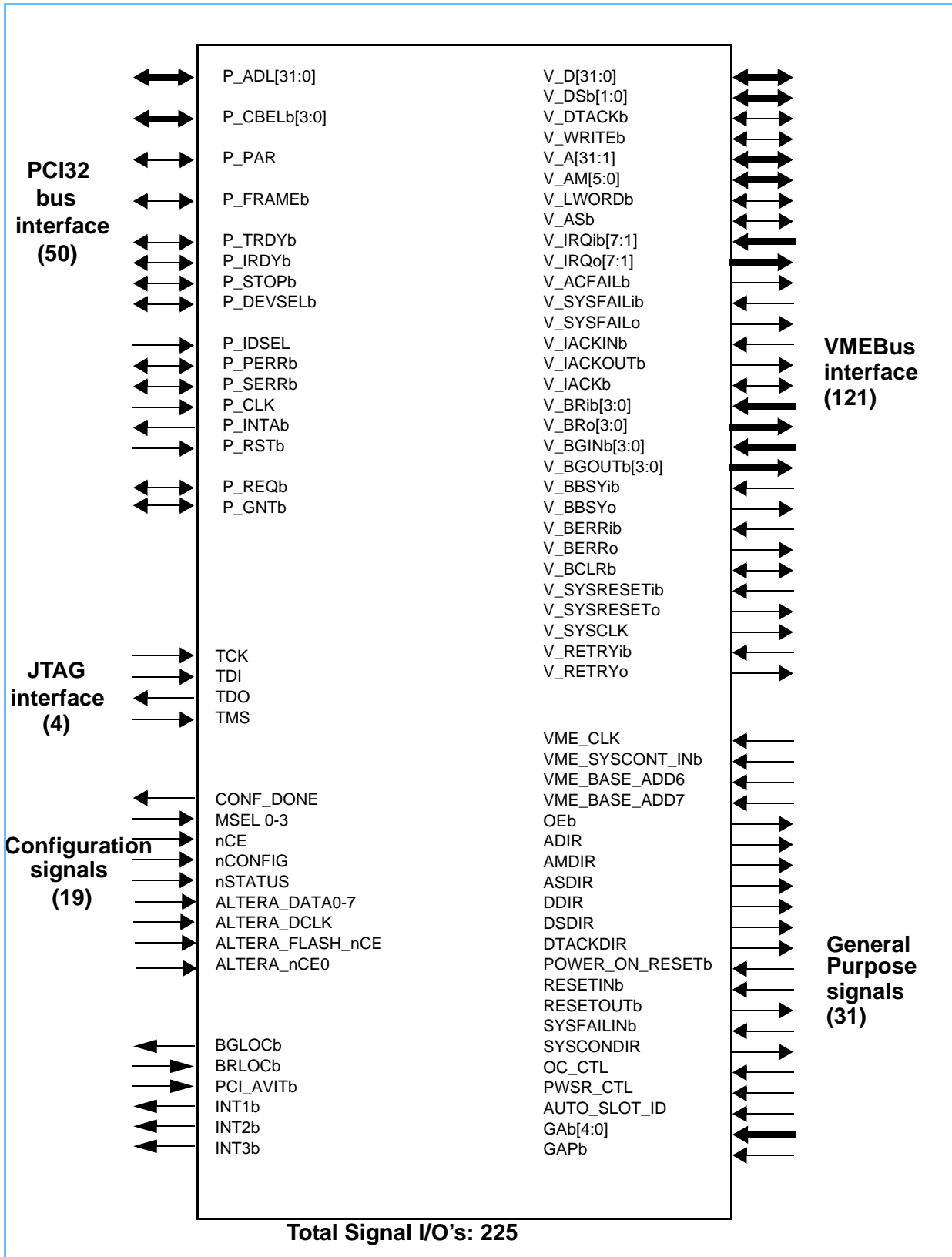

Figure 5 : ALMA2f Signal Pins block diagram

3.1 VME bus interface signals

All Pull-Down resistors must be lower or equal to 3KOhm

Signal name	I / O	Output Type	External Pull-Up Pull-Down	Description
V_A[31:1]	I/O	t/s		VME Address bus
V_ACFAILib	I			Power Fail
V_AM[5:0]	I/O	t/s		Address Modifiers
V_ASb	I/O	t/s	Pull-Up	Address Strobe
V_BCLRb	I/O	t/s	Pull-Up	Bus Clear
V_BBSYib	I			Bus Busy input
V_BBSYo	O			Bus Busy output
V_BERRib	I			Bus Error input
V_BERRo	O			Bus Error output
V_BGINb[3:0]	I			Bus Grant daisy-chain input
V_BGOUTb[3:0]	O			Bus Grant daisy-chain output
V_BRib[3:0]	I			Bus Request input
V_BRo[3:0]	O			Bus Request output
V_D[31:0]	I/O	t/s		VME Data bus
V_DTACKb	I/O	t/s	Pull-Up	Data Transfer Acknowledge
V_DSb[1:0]	I/O	t/s	Pull-Up	Data Strobes
V_IACKb	I/O	t/s		Interrupt Acknowledge
V_IACKINb	I			Interrupt Acknowledge daisy-chain input
V_IACKOUTb	O			Interrupt Acknowledge daisy-chain output
V_IRQib[7:1]	I			Interrupt Request input
V_IRQo[7:1]	O			Interrupt Request output
V_LWORDb	I/O	t/s		indicates size of data transaction
V_RETRYib	I			VMEbus 2eSST RETRY* Signal (For 2eSST protocol only)
V_RETRYo	O			VMEbus 2eSST RETRY* Signal (For 2eSST protocol only)
V_SYSCLK	O	t/s		System Clock signal output
V_SYSFAILib	I			System Fail input
V_SYSFAILo	O			System Fail output
V_SYSRESETib	I			System Reset signal input
V_SYSRESETo	O			System Reset signal output
V_WRITEb	I/O	t/s		Write signal

3.2 PCI bus interface signals

Signal name	I / O	Out-put-Type	External Pull-up, Pull-down	Description
P_CLK	I			PCI Bus Clock
P_ADL[31:0]	I/O	t/s		PCI Address/Data Bus
P_CBELb[3:0]	I/O	t/s		Command / Byte Enable: 4-bit multiplexed bidirectional bus that transfers bus command and bytes enables. During the address phase of a transaction, these signals define the bus command. During the data phase they are used as byte enables. The byte enables are valid during the entire data phase and determine which byte lanes carry meaningful data.
P_PAR	I/O	t/s		Parity bit , is even parity across P_ADL[31:0] and P_CBELb[3:0]. The master drives P_PAR for address and write data phases; the target drives P_PAR for read data phases.
P_IDSEL	I			Initialization Device Select: is used as a chip select during CONFIGURATION read and write transactions
P_DEVSELb	I/O	s/t/s	Pull-Up	Device Select. When actively driven , indicates the driving device has decoded its address as the target of the current access.
P_FRAMEb	I/O	s/t/s	Pull-Up	Cycle Frame is driven by the current master to indicate the beginning and duration of an access. P_FRAMEb is asserted to indicate a bus transaction is beginning. While this signal is asserted, data transfers continue. When it is deasserted, the transaction is in final data phase.
P_IRDYb	I/O	s/t/s	Pull-Up	Initiator Ready: indicates the signal is driven by the initiating agent's (bus master's) ability to complete the current data phase of the transaction. During a write operation, P_IRDYb indicates that a valid data is present on P_AD[31:0]. During a read operation, it indicates the master is prepared to accept data.
P_TRDYb	I/O	s/t/s	Pull-Up	Target Ready indicates the target agent's (selected device's) ability to complete the current data phase of the transaction. During a read operation, P_TRDYb indicates that valid data is present on P_AD[31:0]. During a write operation, it indicates the target is prepared to accept data
P_STOPb	I/O	s/t/s	Pull-Up	Stop signal indicates the current target is requesting the master to stop the current transaction
P_PERRb	I/O	s/t/s	Pull-Up	Parity error , is used by ALMA2f for the reporting of data parity errors during write transactions as a target or during read transactions as a master
P_SERRb	I/O	o/d	Pull-Up	System error , is used by ALMA2f for the reporting of address parity errors during read/write transactions as a target.
P_RSTb	I			PCI RESET: this signal is used to identify if ALMA2f is connected to a PCI32 or a PCI64 bus.
P_REQb	O	t/s		Bus Request , is ALMA2f bus request to an external PCI arbiter.

Signal name	I/O	Output-Type	External Pull-up, Pull-down	Description
P_GNTb	I	t/s		Bus Grant , is ALMA2f bus grant from an external PCI bus arbiter.
P_INTAb	O	o/d	Pull-Up	Interrupt A : is used to request an interrupt.

3.3 General purpose signals

Signal name	Type	Output Type	External Pull-up Pull-down	Description
ADIR	O			Address direction for VME-Local transceivers (At Power-On-Reset this signal is forced to low level)
AMDIR	O			Address Modifier direction for VME-Local transceivers (At Power-On-Reset this signal is forced to low level)
ASDIR	O			Address Strobe direction for VME-Local transceivers (At Power-On-Reset this signal is forced to low level)
BGLOCb	O			<p>PCI Local Bus Grant data output: Belongs to the External VMEbus Requesting feature protocol. Used optionally to prevent deadlocks. When asserted, grants the VMEbus to the PCI bus master which asserted BRLOCb. (used optionally by a PCI bus master which does not support the PCI Retry protocol).</p> <p>(PCI sideband signal)</p>
BRLOCb	I			<p>PCI Local Bus Request: Belongs to the External VMEbus Requesting feature protocol. Used to prevent deadlocks from concurrent VME and PCI accesses. When asserted, forces ALMA2f to request VMEbus ownership (used optionally by a PCI bus master which does not support the PCI Retry protocol).</p> <p>(PCI sideband signal)</p>
DDIR	O			Data direction for VME-Local transceivers (At Power-On-Reset this signal is forced to low level)
RESERVED1	I			RESERVED. No Pull-Up or Pull-Down required
DTACKDIR	O			Acknowledge direction for VME-Local transceivers (At Power-On-Reset this signal is forced to low level)
DSDIR	O			Data Strobes direction for VME-Local transceivers (At Power-On-Reset this signal is forced to low level)
INT1b	O	o/d	Pull-Up	ALMA2f Interrupt Request 1 (PCI sideband signal)
INT2b	O	o/d	Pull-Up	ALMA2f Interrupt Request 2 (PCI sideband signal)
INT3b	O	o/d	Pull-Up	ALMA2f Interrupt Request 3 (PCI sideband signal)

Signal name	Type	Output Type	External Pull-up Pull-down	Description
PCI_AVITb	I			Interrupt Request from PCI Agent (PCI sideband signal): A VME cycle or a VME Interrupt is generated according to bit 7 of the IT_AVIT_CTRL register (Address 0xF4)
AUTO_SLOT_ID	I			Auto slot ID. Active High =1 - See paragraph 5.12
GAb[4:0]	I			Geographical Addressing: used by VME64x boards to automatically identify into which VME64x backplane slot it is plugged.
GAPb	I			Geographical Addressing Parity
POWER_ON_RESETb	I			Power-On-Reset from board: active Low = 0
PWSR_CTL	I		Varies with configuration	Power System Reset Control When POWER_ON_RESETb signal becomes active, the V_SYSRESETo and V_SYSFAILo signals are disabled if that pin = 1, are enabled if that pin=0
OC_CTL	I		Varies with configuration	Open Collector Control must be tied to 0 if inverting external OC buffers are used must be tied 1 with non-inverting external OC buffers
OEb	O		Pull-Up	Global Output Enable for VME-Local transceivers (optional use)
RESETINb	I			Reset input from board
RESETOUTb	O			Reset output for board reset
SYSCONDIR	O			Direction for V_BCLRb and V_SYSCLK VME-Local transceivers (At Power-On-Reset this signal is forced to low level)
SYSFAILINb	I			System fail hardware input
VME_BASE_ADD7	I		Varies with configuration	Enable external sample of base address in slave mode A16
VME_BASE_ADD6	I		Varies with configuration	Base address in slave mode A16
VME_CLK	I			VME Clock up to 64 Mhz
VME_SYSCONT_INb	I		Varies with configuration	VME System Controller input: ALMA2f is VME System Controller if sampled Low =0 after Reset

3.4 JTAG signals

Signal name	I / O	Output Type	External Pull-up Pull-down	Description
TCK	I			JTAG Clock
TDI	I			JTAG Data input
TDO	O	t/s		JTAG Data output
TMS	I			JTAG Mode Select
TRSTb	I			JTAG Reset

3.5 FPGA Configuration signals

Signal name	I / O	Output Type	External Pull-up Pull-down	Description
CE1_DI1	↓		Vdd⁺	Driver Inhibit1
CE1_DI2	↓		Vdd⁺	Driver inhibit2
CE0_TEST	↓		Gnd²	Test C Clock
CE0_IO	↓		Gnd²	
CE1_RI	↓		Vdd⁺	Receiver inhibit

Note 1: ~~This test signal is for manufacturing use only.
It must be pulled up or tied to Vdd for normal ALMA2f operation.~~

Note 2: ~~This test signal is for manufacturing use only.
It must be pulled down or tied to Gnd for normal ALMA2f operation.~~

Chapter 4. PACKAGING

Top View - Wire Bond Cyclone III - EP3C25F324I7

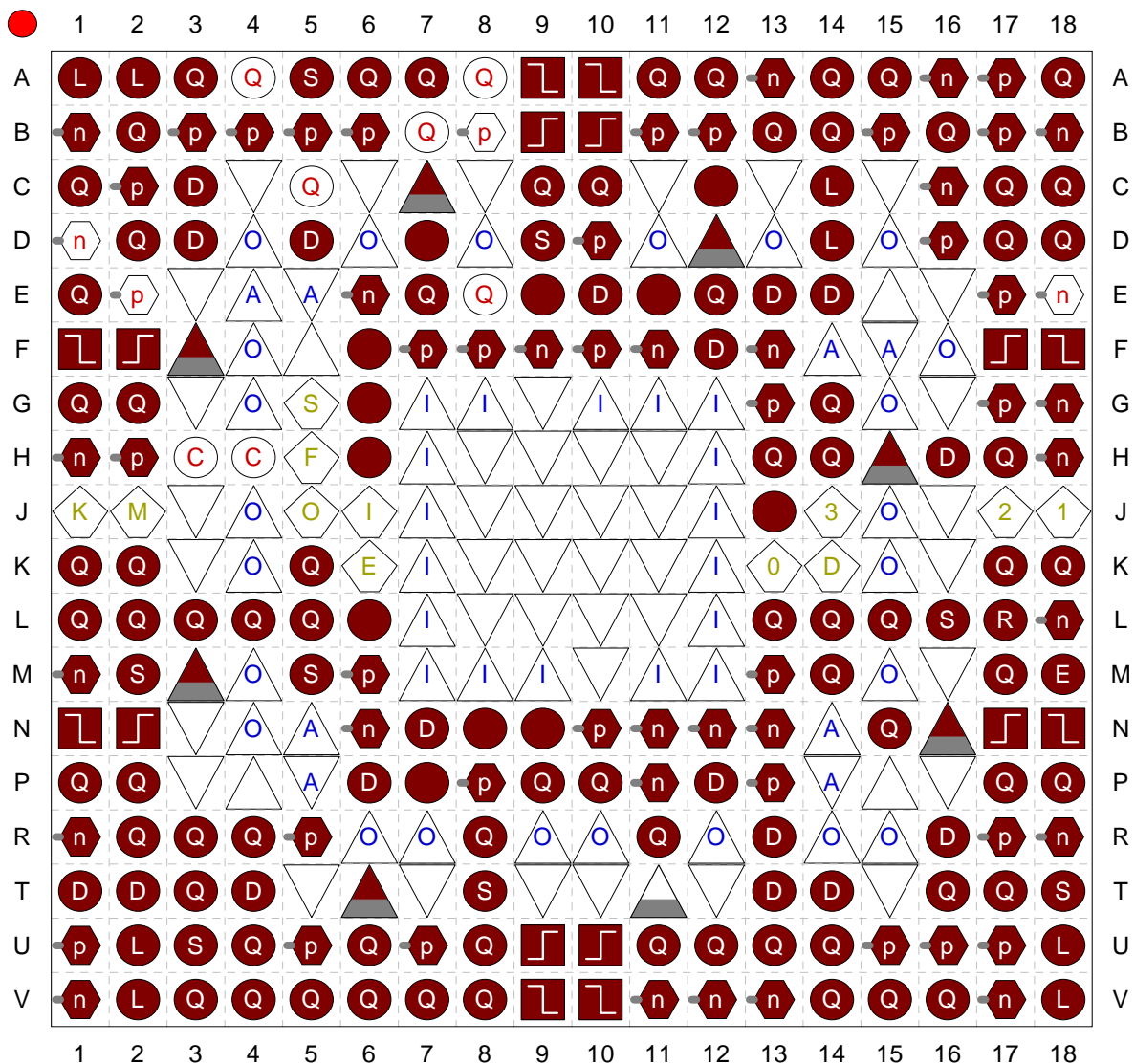

Figure 6 : Top view EPC325F324I7

Table 1: ALMA2f pin assignment

Pin / Signal name	Pin / Signal name	Pin / Signal name	Pin / Signal name	Pin / Signal name
A01 DDIR	A02 V_DSb[1]	A03 V_DSb[0]	A04 ALTERA_DATA7	A05 V_D[6]
A06 V_ASb	A07 V_LWORDb	A08 ALTERA_DATA2	A09 V_BRib[0]	A10 V_BRib[1]
A11 ADIR	A12 V_WRITEb	A13 V_A[18]	A14 V_BRo[2]	A15 V_BCLRb
A16 V_A[16]	A17 V_A[13]	A18 V_A[14]		B01 V_BERRo
B02 V_IRQib[5]	B03 V_D[11]	B04 V_D[7]	B05 V_D[8]	B06 V_AM[4]
B07 ALTERA_DATA4	B08 ALTERA_DATA3	B09 V_BRib[2]	B10 V_SYSFAILib	B11 V_AM[5]
B12 V_A[26]	B13 V_A[25]	B14 V_A[19]	B15 V_AM[3]	B16 V_A[12]
B17 V_A[15]	B18 V_A[10]	B19 V_DS1b	C01 V_BBSYib	C02 V_IRQib[7])
C03 V_D[5]	C04 GND	C05 ALTERA_DATA5	C06 GND	C07 ASDIR
C08 GND	C09 V_AM[0]	C10 V_A[21]	C11 GND	C12 V_A[22]
C13 GND	C14 V_A[17]	C15 GND	C16 V_A[6]	C17 V_A[9]
C18 V_A[7]		D01 ALTERA_ASDO_DATA1	D02 V_BBSYo	D03 V_D[12]
D04 VCCIO8	D05 V_D[9]	D06 VCCIO8	D07 V_D[4]	D08 VCCIO8
D09 V_AM[1]	D10 V_A[27]	D11 VCCIO7	D12 AMDIR	D13 VCCIO7
D14 V_A[20]	D15 VCCIO7	D16 V_AM[2]	D17 V_A[11]	D18 V_A[4]
	E01 V_SYSCLK	E02 ALTERA_FLASH_nCE	E03 GND	E04 VCCA3
E05 GNDA	E06 V_IRQib[4]	E07 V_D[1]	E08 ALTERA_DATA6	E09 ALTERA_DATA6
E10 V_A[28]	E11 V_A[31]	E12 V_BRo[3]	E13 V_A[8]	E14 V_IRQo[3]
E15 VCCD_PLL2	E16 GND	E17 V_A[5]	E18 ALTERA_nCEO	
F01 V_BERRib	F02 VME_CLK	F03 DSDIR	F04 VCCIO1	F05 VCCD_PLL3
F06 V_D[25]	F07 V_D[10]	F08 V_IRQo[6]	F09 V_A[24]	F10 V_A[29]
F11 V_IRQo[7]	F12 V_BRo[1]	F13 V_BRo[0]	F14 VCCA2	F15 GNDA
F16 VCCIO6	F17 V_BGINb[0]	F18 V_RETRYib		G01 DTACKDIR
G02 V_IRQib[3]	G03 GND	G04 VCCIO1	G05 nSTATUS	G06 V_BGINb[3]
G07 VCCINT	G08 VCCINT	G09 GND	G10 VCCINT	G11 VCCINT
G12 VCCINT	G13 V_BGOUTb[0]	G14 V_A[2]	G15 VCCIO6	G16 GND
G17 V_BGOUTb[2]	G18 V_RETRYo		H01 V_DTACKb	H02 V_D[21]
H03 ALTERA_DATA0	H04 ALTERA_DCLK	H05 nCONFIG	H06 V_D[26]	H07 VCCINT
H08 GND	H09 GND	H10 VDD	H11 GND	H12 VCCINT
H13 V_BRib[3]	H14 V_A[30]	H15 V_A[1]	H16 V_BGINb[1]	H17 V_A[3](4)
H18 SYSCONDIR		J01 #TCK	J02 #TMS	J03 GND
J04 VCCIO1	J05 #TDO	J06 #TDI	J07 VCCINT	J08 GND
J09 VDD	J10 GND	J11 GND	J12 VCCINT	J13 V_A[23]
J14 MSEL3	J15 VCCIO6	J16 GND	J17 MSEL2	J18 MSEL1
	K01 V_D[24]	K02 V_D[14]	K03 GND	K04 VCCIO2
K05 V_D[0]	K06 nCE	K07 VCCINT	K08 GND	K09 GND
K10 GND	K11 GND	K12 VCCINT	K13 MSEL0	K14 CONF_DONE
K15 VCCIO5	K16 GND	K17 INT3b	K18 V_BGOUTb[1]	

Pin / Signal name	Pin / Signal name	Pin / Signal name	Pin / Signal name	Pin / Signal name
L01 V_D[19]	L02 V_D[29]	L03 V_D[31]	L04 AUTO_SLOT_ID	L05 RESETINb
L06 RESETOUTb	L07 VCCINT	L08 GND	L09 VDD	L10 GND
L11 VDD	L12 VCCINT	L13 V_IRQib[1]	L14 V_SYSRESETib	L15 V_BGINb[2]
L16 V_SYSFAILo	L17 V_IRQo[5]	L18 INT2b		M01 V_D[17]
M02 V_D[22]	M03 V_D[13]	M04 VCCIO2	M05 OEb	M06 P_AD[25]
M07 VCCINT	M08 VCCINT	M09 VCCINT	M10 GND	M11 VCCINT
M12 VCCINT	M13 P_AD[10]	M14 V_SYSRESETo	M15 VCCIO5	M16 GND
M17 V_BGOUTb[3]	M18 V_IRQo[2]		N01 V_IRQib[6]	N02 V_IRQib[2]
N03 GND	N04 VCCIO2	N05 VCCA1	N06 P_AD[24]	N07 P_AD[22]
N08 P_AD[18]	N09 P_TRDYb	N10 P_STOPb	N11 P_PERRb	N12 P_AD[14]
N13 P_AD[9]	N14 VCCA4	N15 V_IRQo[4]	N16 POWER_ON_RESETb	N17 VME_SYSCONT_INb
N18 BRLOCb		P01 V_D[23]	P02 V_D[30]	P03 GND
P04 VCCD_PLL1	P05 GNDA	P06 P_CBEb[3]	P07 P_AD[21]	P08 P_AD[17]
P09 P_DEVSELb	P10 RESERVED_INPUT	P11 P_SERRb	P12 P_AD[13]	P13 P_AD[8]
P14 GNDA	P15 VCCD_PLL4	P16 GND	P17 SYSFAILINb	P18 BGLOCb
	R01 V_D[28]	R02 V_D[16]	R03 V_D[15]	R04 PCI_AVITb
R05 V_D[2]	R06 VCCIO3	R07 VCCIO3	R08 P_AD[16]	R09 VCCIO3
R10 VCCIO4	R11 P_PAR	R12 VCCIO4	R13 P_CBEb[0]	R14 VCCIO4
R15 VCCIO5	R16 V_ACFAILib	R17 V_IACKINb	R18 INT1b	
T01 V_D[27]	T02 V_D[18]	T03 V_D[20]	T04 P_AD[30]	T05 GND
T06 io_oc_ctl	T07 GND	T08 P_CBEb[2]	T09 GND	T10 GND
T11 RESERVED_INPUT	T12 GND	T13 P_AD[7]	T14 P_AD[4]	T15 GND
T16 V_IACKb	T17 V_IACKOUTb	T18 V_IRQo[1]		U01 P_INTAb
U02 PWSR_CTL	U03 P_REQb	U04 P_AD[29]	U05 P_AD[27]	U06 P_IDSEL
U07 P_AD[20]	U08 P_FRAMEb	U09 P_CLK	U10 VME_BASE_ADD_7	U11 P_CBEb[1]
U12 P_AD[12]	U13 P_AD[6]	U14 P_AD[3]	U15 P_AD[1]	U16 GAb[4]
U17 GAb[3]	U18 GAb[2]		V01 P_GNTb	V02 GAPb
V03 P_AD[31]	V04 P_AD[28]	V05 P_AD[26]	V06 P_AD[23]	V07 P_AD[19]
V08 P_IRDYb	V09 P_RSTb	V10 VME_BASE_ADD_6	V11 P_AD[15]	V12 VCC
V13 P_AD[5]	V14 P_AD[2]	V15 P_AD[0]	V16 RESERVED_INPUT	V17 GAb[1]
V18 GAb[0]				

- VCCA1, VCCA2, VCCA3, VCCA4 : **2.5 V**
- VCCD_PLL1, VCCD_PLL2, VCCD_PLL3, VCCD_PLL4: **1.2 V**
- VCCINT : **1.2 V**
- VCCIO1, VCCIO2, VCCIO5, VCCIO6, VCCIO7, VCCIO8, : **3.3 V**
- VCCIO3, VCCIO 4 : **3.0 V**
- GNDA
- GND

Chapter 5. INITIALIZATION & RESET

5.1 Overview

ALMA2f reset logic handles five reset sources as listed below:

- 1 • Power-on reset: when input **POWER_ON_RESETb** is asserted low.
- 2 • VME system reset: when input **V_SYSRESETb** is asserted low.
- 3 • Local (board) reset: when input **RESETINb** is asserted low. (this pin could by example be connected to the card hard reset (Reset button) or to the PCI bus reset signal (RST#))
- 4 • Addressed reset: when register UTIL_RST[9:8] at address 0x65 is written (from either VMEbus or PCI bus)
- 5 • Reset Watchdog Time Out: when ALMA2f Reset Watchdog timer times out

Depending upon which reset source is activated, ALMA2f takes one or several of the following reset actions:

- Reset of ALMA2f internal logic: Internal reset (note that some registers can only be reset through pin **POWER_ON_RESETb**)
- Generation of the VME system reset: output pin **V_SYSRESETo** is asserted high
- Generation of local (board) reset: output pin **RESETOUTb** is asserted low

The following table describes how reset actions taken by ALMA2f are controlled.

Reset Source	V_SYSRESETo	RESETOUTb	Internal Reset
POWER_ON_RESETb	asserted	asserted	performed
V_SYSRESETib		asserted	performed
RESETINb	asserted if ALMA2f is VME System Controller and UTIL_RST [LOC2VME] = 1	asserted	performed
Addressed Reset	asserted if UTIL_RST [ADD[1:0]]= 01 or 11	asserted if UTIL_RST [ADD[1:0]]= 10 or 11	performed
Watchdog	no action	asserted	performed

The bit 8 of the UTIL_VMECNTL Register is a Read-only status bit UTIL_SYSRESET[ext] that indicates to what state is the signal **SYSRESET*** on the VMEbus.

Bit	UTIL_VMECNTL Register - address 0x68
8	UTIL_SYSRESET[ext] bit 0 SYSRESET* is inactive 1 SYSRESET* is active ALMA2f is either generating V_SYSRESETo or receiving V_SYSRESETib .

The Software (PCI bus devices) can check, by testing this bit 8, that no VME **SYSRESET*** is active, in order to avoid unsuccessful access to the VMEbus, while it is being initialized.

5.2 Reset with POWER_ON_RESETb

The typical sequence of Reset actions is the following:

- Upon **POWER_ON_RESETb** assertion (low), ALMA2f performs Internal reset and generates **V_SYSRESETo** and **RESETOUTb**.
- Upon de-activation of **POWER_ON_RESETb** a 40ms timer is started.
- Upon the 40ms timer expiration, the VME System Controller pin (VME_SYSCONT_INb) is sampled (see chapter 5.8 "Sampling VME System Controller pin" on page 140). hardware configurations are sampled (see chapter 5.7 "Sampling hardware configurations" on page 140). a new timer of 161ms is started.
- . Upon the 161ms timer expiration (all board power supplies are now stabilized), **V_SYSRESETo**, **RESETOUTb** and Internal reset are de-activated.

Note: The VME norm requires that the minimum active duration of **SYSRESET*** by any board to be at least 200ms)

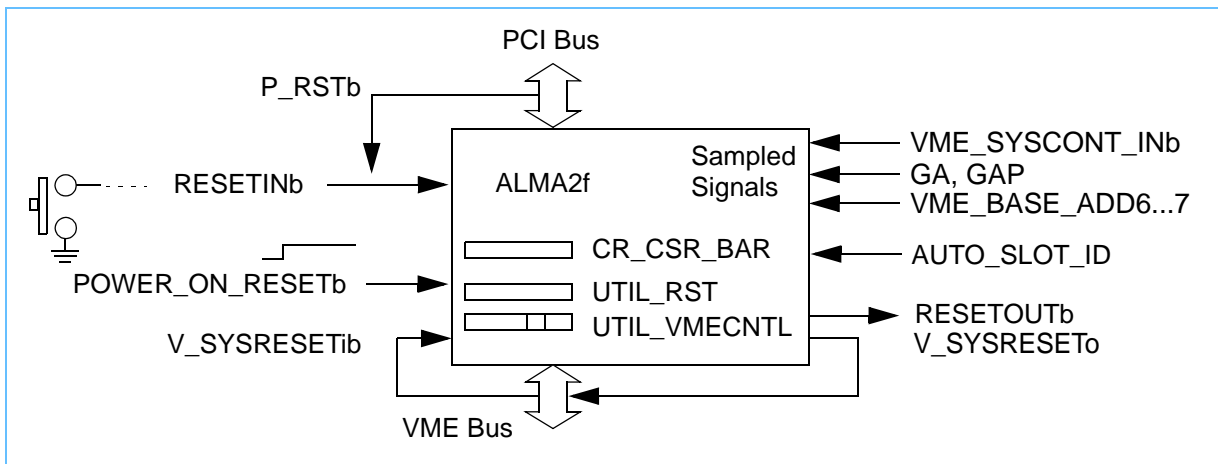

Schematic for Reset with ALMA2f

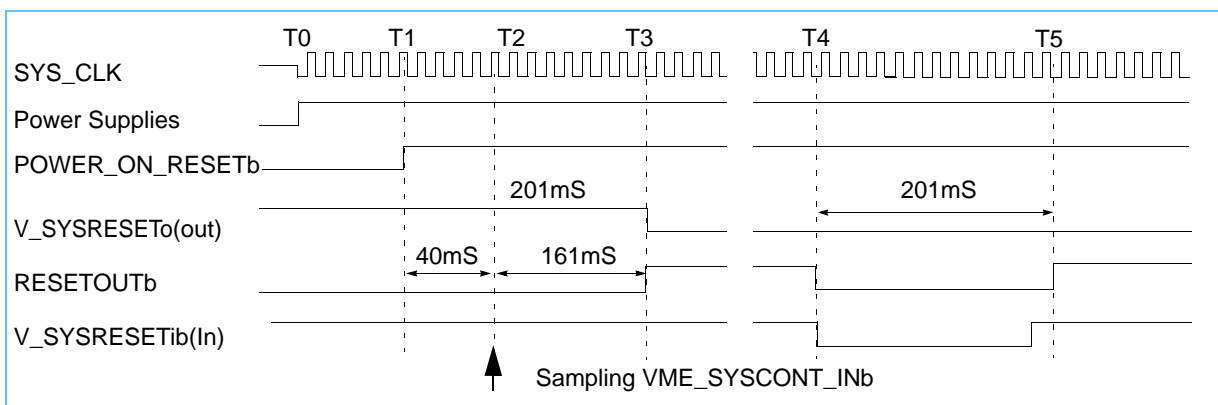

Figure 5-1. PowerOn Reset with ALMA2f

5.3 Reset controlled by the RESETINb input

The sequence of actions is the following:

- Upon assertion (low) of **RESETINb**, ALMA2f performs an internal reset and generates **RESETOUTb**. Moreover, in the case where ALMA2f is configured as VME System Controller (register bit \$VME_ARB_SYSCONTb @71 is set to 1 - (see chapter 5.8 "Sampling VME System Controller pin" on page 140).) and, provided register bit \$UTIL_RST_LOC2VME @64 is set to 1, then ALMA2f also generates **V_SYSRESETo** for at least 201ms.

Note: ALMA2f propagates normally VME daisy-chains when it is not generating **V_SYSRESETo**.

- Upon de-activation of **RESETINb**, ALMA2f de-activates **RESETOUTb** and Internal reset; hardware configurations are sampled ((see chapter 5.7 "Sampling hardware configurations" on page 140).).

Note: In the case where **RESETINb** is activated for less than 201ms **V_SYSRESETo** being timed by ALMA2f (generated during 201ms) the PCI bus central resource must hold any access targeted to the VMEbus until completion of the current VME **SYSRESET*** operation. For that purpose, software can check that no VME **SYSRESET*** is active by reading register bit \$UTIL_SYSRESET @69.

5.4 Reset controlled by the Addressed Reset operation

This type of reset occurs when a Write to bits 8 and 9 of the register UTIL_RST @64 is done from either the VMEbus or PCI bus ALMA2f takes the following actions depending upon the 2-bit value which is loaded into register UTIL_RST [9:8].

Detailed operations controlled by the UTIL_RST_ADD[1:0] bits setting are described below:

Bit(s)	UTIL_RST Register - address 0x64
9-8	UTIL_RST_ADD[1:0] 00 no action, RESETOUTb if active is de-asserted. 01 ALMA2f generates SYSRESET* 10 ALMA2f generates RESETOUTb 11 ALMA2f generates SYSRESET* and RESETOUTb

1. Writing 01 to UTIL_RST_ADD[1:0]:

ALMA2f generates **V_SYSRESETo** for 201ms (even if it is not VMEbus System Controller). Sequence of actions is the following:

- ALMA2f processes the write access to register UTIL_RST_ADD[1:0].
- When the access is completed, ALMA2f performs a brief Internal reset (note that \$UTIL_RST_ADD is not affected), samples hardware configurations (see chapter 5.7 "Sampling hardware configurations" on page 140) generates **V_SYSRESETo** and starts a 201ms timer.
- Upon 201ms timer expiration ALMA2f de-activates **V_SYSRESETo**.

2. Writing 10 to UTIL_RST_ADD[1:0]

ALMA2f generates **RESETOUTb** for 201ms max. Sequence of actions is the following:

- ALMA2f processes the write access to register UTIL_RST_ADD[1:0].
- When the access is completed, ALMA2f performs a brief Internal reset (note that UTIL_RST_ADD is not affected), samples hardware configurations (see «Sampling hardware configurations»), generates **RESETOUTb** and starts a 201ms timer.
- A write to register UTIL_RST_ADD[1:0] with 00 will makes ALMA2f to immediately de-activates **RESETOUTb**. From that point, that signal could be re-asserted only after the watchdog timer has expired (see chapter 5.6 "Reset controlled by the Reset Watchdog" on page 140).
- Upon 201ms timer expiration ALMA2f de-activates **RESETOUTb**.

3. Writing 11 to UTIL_RST_ADD[1:0]

ALMA2f generates both **V_SYSRESETo** (even if it is not VMEbus System Controller) and **RESETOUTb** for 201ms max.

- The two above sequences of actions are performed.

4. Writing 00 to UTIL_RST_ADD[1:0]

ALMA2f de-activates RESETOUTb if it were already active from a previous addressed reset operation, otherwise no action is performed.

The current addressed reset operation being performed by ALMA, can be known by a read to the \$UTIL_RST_ADD[1:0] register.

5.5 Reset controlled by the V_SYSRESETib input (VME SYSRESET*)

Sequence of actions is the following:

- Upon assertion (low) of **V_SYSRESETib**, ALMA2f performs an Internal reset, generates **RESETOUTb** and starts a 201ms timer (201ms is the assumed required time to reset any board local devices).

- Upon either 201ms timer expiration or **V_SYSRESETib** de-activation, ALMA2f de-activates **RESETOUTb** and the internal reset, and samples hardware configurations ((see chapter 5.7 "Sampling hardware configurations" on page 140).).

5.6 Reset controlled by the Reset Watchdog

When reset watchdog times out, sequence of actions is the following:

- . ALMA2f performs internal reset, generates **RESETOUTb** and starts a 201ms timer.
- Upon 201ms timer expiration, ALMA2f de-activates **RESETOUTb** and Internal reset; hardware configurations are sampled ((see chapter 5.7 "Sampling hardware configurations" on page 140).)
- The event, reflected into control signal **UTIL_wdg_reset**, is recorded into Error Status bit[1] (register **UTIL_ERRSTA[7]** @6C) set to a 1 and may generate an interrupt to the PCI bus, (see chapter "Interrupt sources translated to an interrupt to PCI" on page).). This bit, as for the others register bits, could be cleared only upon assertion of **POWER_ON_RESETb**, or via a write to the register.

5.7 Sampling hardware configurations

During resets, ALMA2f samples a given number of input pins which are used to set hard-wired ALMA2f configuration from external switches or pull-up/down resistors. Sampling of these hard-wired inputs is done as follows:

- logical states of pins **VME_BASE_ADD[7:6],GAP,GAB[4:0]** are loaded into register **VME_SLVA[7:0]** @78
 - Bit 7: VME_BASE_ADD7
 - Bit 6: VME_BASE_ADD6
 - Bit 5: GAP
 - Bit 4:0 : GAB[4:0]
- logical state of pins **V_A[8:1]** are loaded into register **UTIL_VMECNTL[23:16]** @6A (no function is attached to this register field)

For explanations about above hard-wired pins, (see Chapter . "SIGNAL DESCRIPTION" on page).

5.8 Sampling VME System Controller pin

During power-on-reset only, ALMA2f samples **VME_SYSCONT_INb** pin by loading its logical state into register bit **VME_ARB_SYSCONTb** @71.

5.9 Suggested usage of RESETINb and RESETOUTb pins

In the case of a so-called «PCI native» machine, PCI bus reset signal (**RST#**) may be directly connected to input **RESETINb** while output **RESETOUTb** stays unused.

In the case of a so-called «VME native» machine, PCI bus reset signal (**RST#**) and other board devices reset inputs may be directly connected to output **RESETOUTb** to allow for resetting of the

whole board from the VME. Input **RESETINb** is then connected to the board reset controller (to the reset button in the more simple case)

5.10 VME SYSFAIL* Handling

The VME SYSFAIL* signal may be controlled by the software through the bit 0 of the UTIL_VMECTRL register at address 0x68:

Bit(s)	UTIL_VMECNTL Register - address 0x68
0	UTIL_SYSFAIL [ext] bit written to a 1 ALMA2f generates SYSFAIL* (asserts V_SYSFAILob low) bit written to a 0 ALMA2f de-activates SYSFAIL* (asserts V_SYSFAILob high)

The initial value of that bit depends upon which type of reset is used.

This bit is initialized to a 0 only in the case where reset is controlled by the **POWER_ON_RESETb** input and provided input **PWSR_CTL** is wired to logic 1.

In all other cases, the UTIL_SYSFAIL bit will be initialized to a 1 (VME **SYSFAIL*** set active)

The VME **SYSFAIL*** signal may also be generated by ALMA2f when the **SYSFAILINb** input is active (asserted low). From that point, ALMA2f will not de-activate VME **SYSFAIL*** until **SYSFAILINb** is disabled (even if bit \$UTIL_SYSFAIL @68 is written to a zero).

The Status of VME **SYSFAIL*** signal can be obtained by reading UTIL_SYSFAIL bit :

- bit 0 read to a 1 --> VME **SYSFAIL*** is inactive
- bit 0 read to a 0 --> VME **SYSFAIL*** is active

This bit reflects the **SYSFAIL*** signal state on the VMEbus (input **V_SYSFAILib**) **whatever the source which issued it, i.e:**

- from the software (a write to register bit \$UTIL_SYSFAIL @68)
- from other VMEbus agents (input **V_SYSFAILib**)
- from the device connected to the **SYSFAILINb** input

The VME **SYSFAIL*** signal when activated by ALMA2f or by any other VME source may potentially generates an interrupt to the PCI (see chapter "Interrupt sources translated to an interrupt to PCI" on page 130)

It is thus advisable to first mask this interrupt source, before having the software to issue a VME **SYSFAIL***

5.11 Reset Watchdog

A watchdog function is implemented in ALMA2f which, when enabled, dictates the VMEbus or PCI bus master to periodically perform a write access to a particular register to prevent ALMA2f from starting a reset operation as it is described below (see chapter 5.6 "Reset controlled by the Reset Watchdog" on page 140).

This function is enabled when bits [31:16] of the register UTIL_RST, are written to a non-zero value. Maximum time interval allowed between 2 register write accesses is programmed into the following register:

Bits	UTIL_RST Register - address 0x64
31-16	UTIL_WDOG_VALUE[15:0] x'00 --> Reset watchdog feature is Disabled. x'01 to FF hex --> Reset watchdog feature is Enabled. Time-out is programmable within a range starting from: 4ms (01 hex) up to 262.14 seconds (FF hex), by 4ms steps

5.12 AUTO SLOT ID function

The AUTO SLOT ID Function, is a way to program at reset the CR_CSR_BAR registers of each cards that are on the same back-plane. This permits then to access the registers of ALMA2f.

It starts with all cards posting an interrupt IRQ2 on the Interrupt daisy chain.

AUTO_SLOT_ID function is active only if input signal AUTO_SLOT_ID is at 1

This function is described in the VME64x norm.

5.12.1 AUTO_SLOT_ID is at 1:

During the POWER_ON_RESET and the SYSRESET:

- ALMA2f activates signal SYSFAIL (Active=0).
- ALMA2f generates an interrupt IT2 on IRQ2
- The Register CR_CSR_BAR is Reset to 00
- All access to ALMA2f registers with AM=0x2F are inhibited
- ALMA2f respond 0xFE at the first IT2 Acknowledgement cycle

After RESET desactivation:

The monarch (*see following note) waits for the SYSFAIL desactivation from all the VME boards before starting IT2 Acknowledgement cycles

The AUTO_SLOT_ID function can be disabled by software with the following sequence;

- Write in register IT_IRQ_GEN @ 0xF8 to deactivate interrupt IRQ2
- Write in register CR_CSR_BAR to prevent the ALMA2f respond 0xFE at the first IT2 Acknowledgement cycle
- Write in register VME_SLV @ 0x7A (VME Slave Control Register) bit 6 to 1 to authorize access from VME with AM=0x2F
- Write in register UTIL_VMECTL @ 0x68 for SYSFAIL desactivation.

5.12.2 Normal AUTO_SLOT_ID operations:

The monarch, wait until desactivation of the SYSFAIL.

If the interrupt IRQ2 is active, the IT2 Acknowledgement cycle must be done

If on the IT2 Acknowledgement the answer is not 0xFE, the protocol of AUTO_SLOT_ID is stopped.

If on the IT2 Acknowledgement the answer is 0xFE, the monarch can set the register CR_CSR_BAR (address offset 0x7FFFF) on an access with AM=0x2F and Base Address = 00

Same operation is repeated until interrupt IRQ2 remains active.

At the end of the sequence the Slave Canal Register AM=0x2F is set for all the cards attached to the VME in the back plane.

Note: ALMA2f as Monarch

ALMA2f is not able to acknowledge its own interrupt IRQ2.

ALMA2f is monarch only if it is also System controller.

In this case the software must first deactivate its interrupt by programming CR_CSR_BAR in the first card and then Acknowledge the interrupt IRQ2s.

Only 2 sources of reset can activate the AUTO_SLOT_ID signal:

- POWER_ON_RESETb signal
- V_SYSRESETIb signal

The other sources of reset prevent VME accesses with AM=0x2F, but the CR_CSR_BAR setting is maintained.

It is required to set bit 6 to 1 of the VME Slave Control register @ 0x7A to permit VME access with AM=0x2F

5.12.3 input signal AUTO_SLOT_ID is at 0:

The Geographical Address GAs signals are sampled and stored in the CR_CSR_BAR Register if the parity is compliant with the GAPb.

If the GA Parity is wrong, 0x1E is stored in the CR_CSR_BAR Register.

Chapter 6. INTERRUPTS

6.1 Interrupt Management overview

ALMA2f implements an interrupt handler which supports the following operations:

- Incoming interrupts connected to pin PCI_AVITb.
- Masking of interrupt sources which can produce an interrupt to the PCI.
- Generation of interrupts to the PCI.
- Generation of interrupts to the VME
- Handling the interrupt acknowledge cycles on VME

Interrupt Registers

0xE0	4 bytes	IT_INT_MSKSRC	Interrupt Source Mask Register (P_INTAb)
0xE4	4 bytes	IT_INT_MSKOUT	PCI Interrupt Mask Register
0xE8	4 bytes	IT_INT_STATUS	Interrupt Status Register
0xEC	2 bytes	IT_INT_CTRL	PCI Interrupt Type Register
0xEE	2 bytes	IT_ADD_SET	Addressed Interrupt Register
0xF0	4 bytes	IT_AVIT_ADD	AVIT VME cycle Address Register
0xF4	1 bytes	IT_AVIT_CTRL	AVIT VME cycle Control Register
0xF5	1 bytes	IT_AVIT_DATA	AVIT VME cycle Data Register
0xF6	1 bytes	IT_AVIT_STA	AVIT Interrupt Status Register
0xF7	1 bytes	IT_IRQ_VEC	VME IRQ* Vector Register
0xF8	1 bytes	IT_IRQ_GEN	VME IRQ* Generation Register
0xF9	7 bytes	IT_ACK1 ...7	VME IACK Level 1 ... Level 7 Registers
0x1E0	4 bytes	CSR_USER_DEF_INT_MSKOUT1	Interrupt Mask register1 (INT1b)
0x1E4	4 bytes	CSR_USER_DEF_INT_MSKOUT2	Interrupt Mask register2 (INT2b)
0x1E8	4 bytes	CSR_USER_DEF_INT_MSKOUT3	Interrupt Mask register3 (INT3b)
0x1EC	4 bytes	CSR_USER_DEF_INT_MSKFAIL	Interrupt Mask FAIL register

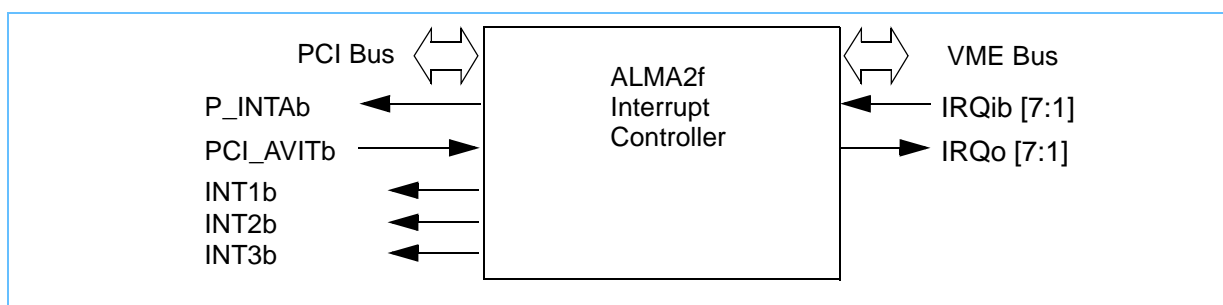

Figure 6-1. Interrupt Signals controlled by ALMA2f

6.2 Generating Interrupt to the VME from the PCI_AVITb pin

This feature is useful for a «standalone» board in order to be able to generate an interrupt to the VME by connecting a PCI interrupt signal (INTA# for example) to pin PCI_AVITb.

According to programmed value of the following configuration bit, the generated VME interrupt can be materialized either by a VME IRQ7-1* interrupt signals activation or via generation of a specific VME cycle called «AVIT VME cycle».

IT_AVIT_IRQSEL = bit 7 of the register IT_AVIT_CTRL[7] at address 0xF4

0 --> PCI_AVITb pin assertion is translated into an «AVIT VME cycle» (Read or Write)

1 --> PCI_AVITb pin assertion is translated into a VME IRQ7-1* interrupt

6.2.1 «AVIT VME cycle»

A low level applied on input pin **PCI_AVITb** will make ALMA2f to request a VME access D08(E0) to the address programmed into the register: IT_AVIT_ADD[31:0] at address 0xF0

The VME cycle is of type «ODD» or «EVEN» depending upon the value of the bit 0:

IT_AVIT_ADD[0]=0 --> EVEN (data is mapped to D08-D15)

IT_AVIT_ADD[0]=1 --> ODD (data is mapped to D00-D07)

The VME cycle Address Modifier is programmed into the register IT_AVIT_CTRL[5:0] at address 0xF4. No coherency checking is done by ALMA2f on the Address Modifier provided. to VME.

The VME cycle Read or Write mode is programmed into the register IT_AVIT_CTRL[6]

0 --> Write cycle

1 --> Read cycle

In the case of a Write cycle, the 8-bit data provided is programmed into the register: IT_AVIT_DATA[7:0] at address 0xF5

IT_AVIT_DATA[7:0] = data written to the VME

In the case of a Read cycle, data received from the VME is ignored by ALMA2f

When such a «AVIT VME cycle» is acknowledged by the VME (either through **DTACK*** [V_DTACKb] or **BERR*** [V_BERRib]) a status bit will be set to zero in order to disable **PCI_AVITb** interrupt handling. A new **PCI_AVITb** interrupt request could be serviced when the status bit is reset to one, through a write to the bit 0 of the IT_AVIT_STA[0] at address 0xF6

6.2.2 VME Interrupt Request Cycle (IRQ7-1*)

Bits 7 to 1 of register IT_AVIT_DATA[7:1] plays as Enable/Disable bits for VME interrupts **IRQ7*** to **IRQ1*** generated by ALMA2f. A low level applied to pin **PCI_AVITb** will be translated into one or several VME interrupt requests according to those IT_AVIT_DATA[7:1] bits which are set to a one.

The Status bit[0] IT_AVIT_STA is **immediately set to zero (disable state)** and no other **PCI_AVITb** interrupt request could be serviced until this bit had not been set to enable (through a write to this register bit).

6.3 Masking and Generating interrupts to the PCI

Any interrupt generated to the PCI by ALMA2f is sourced by an interrupt source belonging to one of the following group:

- Group of VME interrupt sources (IRQ7-1*)
- Group of Addressed Interrupt sources (0 to 7)
- Group of exceptions, end of DMA or time-out interrupt sources

All these interrupt sources are individually maskable via the Interrupt Source Mask Register depicted below: IT_INT_MSKSRC[31:0] at Address 0xE0

bit=0 --> the corresponding interrupt source is not masked. (validated)

bit=1 --> the corresponding interrupt source is masked (invalidated).

Bit(s)	Interrupt source Masked
0	VME Bus Arbiter time-out (Edge detection)
5 - 1	Reserved
6	End of DMA Channel 1 (Edge detection)
7	End of DMA Channel 0 (Edge detection)
8	Exception VME & PCI (Edge detection)
9	ALMA_V64 asserts BGLOCb pin (the PCI agent which requested the VME bus by asserting the BRLOCb pin, is granted) (Edge detection)
10	ALMA_V64 deasserts BGLOCb pin (ALMA_V64 is asking for the VME bus to be released) (Edge detection)
13 - 11	Reserved
14	SYSFAIL* (Level detection)
15	ACFAIL* (Level detection)
16	Addressed interrupt no 0 (Level detection)
17	Addressed interrupt no 1 (Level detection)
18	Addressed interrupt no 2 (Level detection)
19	Addressed interrupt no 3 (Level detection)
20	Addressed interrupt no 4 (Level detection)
21	Addressed interrupt no 5 (Level detection)
22	Addressed interrupt no 6 (Level detection)
23	Addressed interrupt no 7 (Level detection)
24	Reserved
25	VME IRQ1* (Level detection)
26	VME IRQ2* (Level detection)
27	VME IRQ3* (Level detection)
28	VME IRQ4* (Level detection)
29	VME IRQ5* (Level detection)
30	VME IRQ6* (Level detection)
31	VME IRQ7* (Level detection)

LEVEL:

Following Interrupt sources are detected active on the signal level and therefore are not memorized:

- **VME IRQ7* to IRQ1*** VME interrupt sources on bits [31:25]
- **Addressed Interrupt sources** (Addressed Interrupt no 7 to no 0) on bits [23:16]
- **ACFAIL* and SYSFAIL*** interrupt sources on bits [15:14]

For those Level-detected interrupt source, the generated PCI interrupt stays active until the source itself is disabled (writing a 0 or a 1 to the Interrupt Status Register corresponding bit, would have no effect).

EDGE:

All other interrupt sources are detected active on the signal edge and would be memorized by ALMA2f only if not masked.

For those Edge-detected interrupt source, the generated PCI interrupt stays active until it is cleared by writing a 0 into the corresponding bit in the Interrupt Status Register (writing a 1 to the Interrupt Status Register corresponding bit, would have no effect).

Following are the ALMA2f Exceptions Interrupts sources Edge detected:

- **ALMA2f VMEbus arbiter time out bit [0]** VME_arb_timeoutfail,
- **End of DMA operation on bits[7:6]** DMA_seq_finish0 ..1(channel 0..1) (see "DMA Operation")
- **VME & PCI transfer errors on bit [8]**] (see "Error Handling")
- **ALMA2f VMEbus Locking bits [10:9]:** vme_req_lbg and vme_req_wsr on (see chapter on "Preventing of «deadlocks» using the VMEbus locking feature (under pin control)" -- and -- "Preventing of «deadlocks» using VMEbus locking feature (software control)").

Interrupt Status:

After masking, status of interrupt sources can be obtained by a read to the Interrupt Status Register (only those sources active on edge, are latched):

IT_INT_STATUS[31:0] at address 0xE8

bit n=0 --> interrupt of rank "n" is inactive or invalidated.

bit n=1 --> interrupt of rank "n" is valid

Interrupt Masking:

Valid interrupt sources are translated or not into a PCI interrupt depending upon the PCI Interrupt Mask Register setting:

IT_INT_MSKOUT[31:0] at address 0xE4

bit n=0 --> translation of valid interrupt of rank "n" into an interrupt to PCI is enabled

bit n=1 --> translation of valid interrupt of rank "n" into an interrupt to PCI is disabled

6.3.1 Routing to Interrupt Pin:

The interrupt to PCI is signalled through one the following pins: **P_INTAb** (pin **INTA#** of the PCI bus norm), **INT1b**, **INT2b** or **INT3b**, according to the setting of the bit 11 of the register IT_INT_CTRLat Address 0xEC :

IT_INT_MODE bit 11

0 -->Standard mode:

P_INTAb (INTA#) is activated (asserted low) for any valid interrupt source

1 -->Real Time mode:

P_INTAb (INTA#) is activated (asserted low) for any valid interrupt source unless otherwise specified by registers fields IT_INT_INT1, IT_INT_INT2 and IT_INT_INT3 (see below)

IT_INT_INT1 bit [2:0]

0 Reserved

1 **INT1b** is activated (asserted low) if IRQ1* is valid

2 **INT1b** is activated (asserted low) if IRQ2* is valid

3 **INT1b** is activated (asserted low) if IRQ3* is valid

4 **INT1b** is activated (asserted low) if IRQ4* is valid

5 **INT1b** is activated (asserted low) if IRQ5* is valid

6 **INT1b** is activated (asserted low) if IRQ6* is valid

7 **INT1b** is activated (asserted low) if IRQ7* is valid

IT_INT_INT2[5:3]

0 Reserved

- 1 **INT2b** is activated (asserted low) if IRQ1* is valid
- 2 **INT2b** is activated (asserted low) if IRQ2* is valid
- 3 **INT2b** is activated (asserted low) if IRQ3* is valid
- 4 **INT2b** is activated (asserted low) if IRQ4* is valid
- 5 **INT2b** is activated (asserted low) if IRQ5* is valid
- 6 **INT2b** is activated (asserted low) if IRQ6* is valid
- 7 **INT2b** is activated (asserted low) if IRQ7* is valid

IT_INT_INT3[10:8]

- 0 **INT3b** is activated (asserted low) if Addressed Interrupt n^o 0 is valid
- 1 **INT3b** is activated (asserted low) if Addressed Interrupt n^o 1 is valid
- 2 **INT3b** is activated (asserted low) if Addressed Interrupt n^o 2 is valid
- 3 **INT3b** is activated (asserted low) if Addressed Interrupt n^o 3 is valid
- 4 **INT3b** is activated (asserted low) if Addressed Interrupt n^o 4 is valid
- 5 **INT3b** is activated (asserted low) if Addressed Interrupt n^o 5 is valid
- 6 **INT3b** is activated (asserted low) if Addressed Interrupt n^o 6 is valid
- 7 **INT3b** is activated (asserted low) if Addressed Interrupt n^o 7 is valid

6.3.2 Routing to INT1b,2b,3b pins with CSR_USER_DEF_INT_MSKOUT

The controls of INT1b,2b,3b interrupt output signal is possible with a setting of the bits 11 and 12 of the PCI Interrupt Type register IT_INT_CTRL at address @EC.

When bit 11=0 and bit 12=1 the Interrupts sources are masked by the registers CSR_USER_DEF_INT_MSKOUT1,2,3 and CSR_USER_DEF_INT_MSKFAIL

Example;

The two interrupt outputs INT1b and INT2b can be configured to generate respectively two separate DMA interrupts DMA0 and DMA1 when each DMA operation is done.

The registers programming is:

```
IT_INT_CTRL (0xEC) = 0x00001000
CSR_USER_DEF_INT_MSKOUT1 (0x1E0) = 0xFFFFFFFF7F
CSR_USER_DEF_INT_MSKOUT1 (0x1E4) = 0xFFFFFFFFBF
```

6.4 Interrupt sources translated to an interrupt to PCI

6.4.1 VME interrupts

When a VME interrupt request (**IRQ7-1***) is received by ALMA2f (on pins **V_IRQib[7:1]**) it is translated by ALMA into a maskable interrupt to the PCI. VME interrupts **IRQ7-1**, after masking, are recorded respectively into bits **IT_INT_STATUS[31:25]**.

These interrupt sources are level sensitive. Once the PCI interrupt handler device identified that the interrupt is sourced by a VME **IRQ7-1*** it may ask ALMA2f to generate a VME Interrupt Acknowledge cycle (VME IACK cycle) via a read targeting one of the following virtual ALMA2f byte registers. Each one of these registers, indexed from 1 to 7, is associated with the interrupt level of same value as the index

Note that any write access to these registers is normally acknowledged but will produce no action.

```
IT_ACK1[7:0] @F9
IT_ACK2[7:0] @FA
IT_ACK3[7:0] @FB
IT_ACK4[7:0] @FC
IT_ACK5[7:0] @FD
IT_ACK6[7:0] @FE
IT_ACK7[7:0] @FF
```

Any PCI read access of a Byte size to one of these registers will be forwarded by ALMA2f as a VME IACK D08(O) at the corresponding interrupt level. The interrupt vector received by ALMA2f is then passed as a read data to the PCI (the interrupt vector value is duplicated on the 4 PCI byte lanes).

Note: No checking is performed by ALMA2f about the effective state of the interrupt source

This VME IACK cycle is characterized by the following:

- The **IACK*** signal is activated (asserted low) to notify all the VMEbus devices that the current cycle is an interrupt acknowledge cycle.
- The **level** of the interrupt being acknowledged is encoded on address lines **V_A[3:1]**.

The **IACK*** signal is connected to daisy-chain input **V_IACKINb** (VME **IACKIN***) of the VMEbus arbiter module, and is propagated by ALMA2f to the output **V_IACKOUTb** (VME **IACKOUT***) of the daisy-chain, 30ns after receipt of **V_DSb[1:0]** (VME **DS1-0***). The daisy-chain thus initiated by ALMA2f will be propagated by the other bus devices up to the interrupting device.

6.4.2 Addressed Interrupts

It is possible for the software to generate up to 8 level sensitive interrupts by writing from the VME or PCI ports to the **IT_ADD_SET** register. These so-called Addressed Interrupt sources are set active by writing a one to the bit position corresponding to desired the interrupt source number:

```
IT_ADD_SET[7:0] @EE
  bit N=0 --> Addressed Interrupt source number N is not active
  bit N=1 --> Addressed Interrupt source number N is active
```

Addressed Interrupts 7 to 0, after masking, are recorded into bits **IT_INT_STATUS[23:16]** respectively.

Bits to zero in the write data will not modify the corresponding register bits. This register is readable from the VME or PCI ports.

RESET

The second field of the register allows to selectively de-activate the Addressed Interrupt sources. A given Addressed Interrupt source may be cleared by resetting to zero its associated bit in the register. This is done by writing a data equal to one to the selected register bit associated with that source.

IT_ADD_RESET[7:0] @EF

bit N=0 --> Addressed Interrupt source number N is cleared

bit N=1 --> Addressed Interrupt source number N is not cleared

Bits to zero in the write data will not modify the corresponding register bits. This register is readable from the VME or PCI ports.

6.4.3 ALMA2f exceptions, end of DMA or timeout Interrupts

These interrupts sources refer to the following events listed below. All sources are edge sensitive excepted for the ACFAIL* and SYSFAIL* ones (level sensitive).

All these exceptions are maskable by the bit 8 of the IT_INT_MSKSCR register at address 0xE0.

- VME ACFAIL*: detected when input V_ACFAILb is asserted low.
This interrupt, after masking, is recorded into bit [15] register IT_INT_STATUS
- VME SYSFAIL*: detected when input V_SYSFAILb is asserted low.
This interrupt, after masking, is recorded into bit [14] register IT_INT_STATUS
- VMEbus Locking feature: vme_req_wsr indicates that the software which currently owns the VMEbus is willing to release the bus (through a write to a one of bit \$VME_REQ_LBG).
This interrupt, after masking, is recorded into bit [10] register IT_INT_STATUS.
- VMEbus Locking feature: vme_req_lbg indicates that VMEbus is granted to the software which requested via the bit VME_REQ_LBR.
This interrupt, after masking, is recorded into bit [9] register IT_INT_STATUS.
- VME & PCI transfers errors: this interrupt source is detected active when any one of the transfer errors recorded into the Error Status register bits [21:18] and [13:1] (register UTIL_ERRSTA @6C) becomes true. This interrupt, after masking, is recorded into bit [8] register IT_INT_STATUS.
- End of DMA on Channel 0: detected internally, signal DMA_seq_finish0.
This interrupt, after masking, is recorded into bit [7] register IT_INT_STATUS.
- End of DMA on Channel 1: detected internally, signal DMA_seq_finish1.
This interrupt, after masking, is recorded into bit [6] register IT_INT_STATUS.
- ALMA2f VME arbiter time out: detected internally, signal VME_arb_timeoutfail.
This interrupt source is detected active when the Error Status register bit [0] (register UTIL_ERRSTA @6C) becomes true.

6.5 VMEbus Interrupter

6.5.1 ALMA2f VME interrupt generation through Register:

IT_IRQ_GEN[7:0]

A VME interrupt is issued when one of the 7 VMEbus signals **IRQ7*-IRQ1*** is activated, level 7 having the highest priority (corresponding ALMA2f pins are V_IRQo[7:1] asserted high)

The VME IRQ Generation register (IT_IRQ_GEN), which can be accessed by both the PCI and VME ports allows for generating one or several interrupts. A VME interrupt of level N (N=1 to 7) is issued by ALMA2f when bit N of the register is set to a one together with the enable bit, bit 0, set to a one.

IT_IRQ_GEN[7:0] at address 0xF8

Upon the interrupt acknowledge cycle (VME IACK cycle), ALMA2f will automatically clear the bit which initiated the interrupt. However one can reset the pending interrupt by writing a one to this bit together with writing at the same time a zero to bit 0 (**should be used for debug purpose only**, since this violates the VME norm).

A read to IT_IRQ_GEN[7:0] from the VME or PCI will allow to know the current status of the requests (bit N to a one indicates that VME IRQ*N interrupt is pending)

According to the VME norm, this register can be initialized only via a Power-On-Reset to prevent a pending interrupt not yet acknowledged to be cleared. After any other reset (than the Power-On-Reset) and before any setting of this register, it is advisable to read this register again in order to determine whether it remains an interrupt pending.

VME interrupts may also be generated from the local bus (PCI bus) via the mechanism associated to the pin **PCI_AVITb** ((see chapter 6.2 "Generating Interrupt to the VME from the PCI_AVITb pin" on page 6-129).)

6.6 ALMA2f response to a VME interrupt acknowledge cycle

ALMA2f samples its own interrupt requests when it detects VME **IACK*** (input **V_IACKb** is asserted low). It examines then the VME interrupt requests it has generated in order to find the one which is to the same level than the one being acknowledged.

If it effectively finds a pending interrupt at that level, it executes the following actions:

- it resets of the pending interrupt
- it provides the interrupt vector to the VME data bus bits D00-D07 (**V_D[0:7]**)
- it activates the VME DTACK* signal (**V_DTACKb**)

That principle of releasing the interrupt upon acknowledgment complies with the interrupter mode of ROACK.

The interrupt vector provided by ALMA2f is stored into the 8-bit register IT_IRQ_VEC at address 0xF7 for which:

- the 3 low-order bits encode the level of the VME interrupt
- the 5 high-order bits are coded by the application so that to provide a to specific vector to the VME.

In the case where ALMA2f plays as the VMEbus arbiter and is the originator of the VME interrupt, it is well clear that it does not activate its VME **IACKOUT*** output signal (**V_IACKOUTb**).

If ALMA2f is not the interrupting device, it will propagate the VME **IACKIN*** (**V_IACKINb**) to **IACKOUT*** (**V_IACKOUTb**) «Daisy-Chain» via pins

Chapter 7. ERROR HANDLING

The 32 bit Error Status Register UTIL_ERRSTA at address 0x6C is dedicated for the recording of the error events that ALMA2f is encountering during its operation.

The bit definition is following:

- 0 No VME agent has asserted a V_BBSYb within 8 mS after an arbitrated bus grant by ALMA2f as VME system Controller.
- 1 All PCI Byte Enables lines are inactive (no data to transfer) when ALMA2f is the target of a PCI single data access
- 2 Data beat size is not D32 or D64 when ALMA2f is the target of a VME BLT or MBLT access.
- 3 PCI error (PCI cycle completes with a Target or a Master Abort) when ALMA2f is the target of a VME write posted access
- 4 PCI error (PCI cycle completes with a Target or a Master Abort) when ALMA2f is the target of a VME write (non-posted) access
- 5 PCI error (PCI cycle completes with a Target or a Master Abort) when ALMA2f is the target of a VME read access in Read-Ahead mode (PCI data are prefetched)
- 6 Data transfer timeout when ALMA2f is System Controller. (no VME slave is responding at time out defined by register VME_TIM).
- 7 Watchdog timer not been cleared before time-out after a reset generated by ALMA2f Watchdog function (the Watchdog timer is UTIL_RST[31:16] register).
- 8 VMEbus Error when ALMA2f translates the interrupt from a PCI_AVITb pin assertion into a VME cycle
- 9 ALMA2f is the target of a PCI access for which the PCI Byte Enables pattern is specifying non-adjacent valid bytes (for example: PCI reading/writing only the byte3 and byte1 of the 4-byte data pattern, byte2 and byte0 being not transferred).
- 10 Data beat size is not equal to 32 bits when ALMA2f is the target of a PCI burst access.
- 11 VMEbus Error when ALMA2f is the target of a PCI write posted access.
- 12 VMEbus Error when ALMA2f is the target of a PCI write (non-posted) access.
- 13 VMEbus Error when ALMA2f is the target of a PCI read access (Read-Ahead mode enabled or not).
- 18 VMEbus Error during DMA (Channel 1).
- 19 VMEbus Error during DMA (Channel 0).
- 20 PCI error (Target or Master Abort) during DMA (Channel 1).
- 21 PCI error (Target or Master Abort) during DMA (Channel 0).

Chapter 8. DMA Controller Operations

8.1 Overview

ALMA2f implements a DMA Controller which is offering two independent channels allowing each to move between VMEbus and PCI bus up to 256 MBytes (using VME MBLT cycles) or 128 MBytes (using VME BLT cycles) of data.

The total amount of data to transfer, called «transfer count» is sliced into blocks of data whose size, called «block count», is also programmable. Each block is transferred to the VME through a single bus tenure (ALMA2f keeps the VMEbus until all the data of the block are transferred). During a block transfer, on each data phase (beat) either 64 bits (MBLT) or 32 bits (BLT) of data are exchanged.

While, on the PCI bus side, the same block is subject to multiple PCI burst cycles for being transferred. PCI burst size is of 8 data of 32-bit at the maximum (excepted in the Turbo mode depicted below).

Each one of the DMA channels 0 and 1 can be programmed with the followings:

- A start bit: the DMA starts when this bit is written by the software.
- The transfer direction: from VME to PCI / from PCI to VME.
- A VME starting address: the VME address from which data are read from or written to:
- an address aligned on a 4-byte boundary or a 8-byte boundary for the VME starting address (depending upon VME cycles used are BLT (32-bit data beats) or MBLT (64-bit data beats) respectively).
- A PCI starting address: the PCI address from which data are read from or written to:
- an address aligned on a 4-byte boundary for the PCI starting address (32-bit data beats).
- A transfer count: maximum programmable size is 2 Mega VME data cycles (data beats)
- A block count: maximum programmable size is 256 VME data cycles (data beats)
- VME Address Modifiers of the VME cycles to generate
- PCI Bus Command of the PCI cycles to generate
- An enable bit for allowing block count transfers of the two channels to be interleaved

DMA completes when, its transfer count is exhausted. DMA completion can be signalled via an interrupt to the PCI bus. The event, reflected into the control signal DMA_seq_finish0 / DMA_seq_finish1 is recorded into bits 7 and 6 respectively of the Interrupt Status Register INT_INT_STATUS @E8 (see chapter 6.4 "Interrupt sources translated to an interrupt to PCI" on page 153).

Abnormal conditions during DMAs are recorded into the Error Status Register @6C bits [21:18].

8.2 DMA Channels programming

The two following registers are programmed with the VME starting address for DMA of Channel 0 and 1 respectively.

```
DMA_CHN0_ADDVME[31:0] [0x00] @C0
DMA_CHN1_ADDVME[31:0] [0x00] @D0
```

The two following registers are programmed with the PCI starting address for DMA of Channel 0 and 1.

```
DMA_CHN0_ADDPCI[31:0]   [0x00]   @C4
DMA_CHN1_ADDPCI[31:0]   [0x00]   @D4
```

By reading of these registers one can know the current VME/PCI addresses (these address registers are decremented as data are exchanged between busses). The only allowed data sizes allowed by DMAs being D32 or D64, the address two low significant bits of the above four registers are always ignored on register writes and return zeroes on register reads.

The two following transfer count registers are programmed with the total numbers of VME data cycles (of 32-bit or 64-bit data beats) for DMA of Channel 0 and 1. The loaded value must be equal to the **desired number** of VME data cycles **minus one cycle** (since the zero value is counted)

```
DMA_CHN0_XFRSIZE[21:0]  [0x00000] @C8
DMA_CHN1_XFRSIZE[21:0]  [0x00000] @D8
```

The maximum total amount of data a DMA can transfer is then of 4 Million x VME D64 or D32 data cycles, i.e.:

- 512 MBytes (if VME MBLT (D64) cycles are used) or
- 256 Mbytes (if VME BLT (D32) cycles are used)

By reading of these registers one can know the remaining VME data cycles before DMA is completed.

The two following registers indicate the size of the DMA blocks (in terms of a number of VME data cycles) in which the above total transfer size is broken down, for DMA of Channel 0 and 1. The loaded value must be equal to the **desired number** of VME data cycles **minus one cycle** (since the zero value is counted)

```
DMA_CHN0_BLOCSIZE[7:0]  [0x00]   @CB
DMA_CHN1_BLOCSIZE[7:0]  [0x00]   @DB
```

The maximum amount of data which can be transferred per DMA block (A DMA block is normally transferred on a single VMEbus tenure) is of 256 x VME D64 or D32 data cycles, i.e.:

- 16 Kilobytes (if DMA block is transferred using a VME MBLT (D64) cycle) or
- 8 Kilobytes (if DMA block is transferred using a VME BLT (D32) cycle).

In order to comply with VME norm relating to address boundaries crossing during MBLT (2KBytes address boundary) or BLT (256Bytes address boundary) ALMA2f will automatically stop the current DMA block transfer at the boundary and will resume a new VMEbus tenure to transfer the remaining data of the DMA block. It is however advisable, for performance reasons, to program the DMA block count accordingly to these address boundaries, i.e.: DMA_CHNx_BLOCSIZE[7:0]= hex 3F will give 63+1 VME data cycles in the case where VME D32 cycles are used.

For each Channel, the transfer direction is programmed into bits #2 of the Channel Control Registers:

```
DMA_CHN0_VME2PCI        [0b0]   @CC
DMA_CHN1_VME2PCI        [0b0]   @DC
0 --> Data are read from PCI and written to the VME on Channel 0/Channel 1
1 --> Data are read from VME and written to the PCI on Channel 0/Channel 1
```

For each Channel, VME Address Modifiers are programmed into bits #13 to 8 of the Channel Control Registers:

```
: DMA_CHN0_AM[5:0]       [0x00]   @CD
   DMA_CHN1_AM[5:0]       [0x00]   @DD
```

For each Channel, the PCI Bus Command three high order bits are programmed into the bits 5 to 3 of of the Channel Control Registers:

```
DMA_CHN0_BUSCOM[2:0]    [0xXX]    @CC  
DMA_CHN1_BUSCOM[2:0]    [0xXX]    @DC
```

The PCI Bus Command C/BE[3:0]# (P_CBEb[3:0] pins) will be made up with DMA_CHN0_BUSCOM[2:0] contents concatenated with DMA_CHN0_VME2PCI contents.

For each Channel the Little/Big Endian byte ordering conversion mode to be applied to data bytes is programmed into the following 2-bit registers:

```
DMA_CHN0_LEBE[1:0]      [0b00]    @CD  
DMA_CHN1_LEBE[1:0]      [0b00]    @DD
```

- 0 --> no Little/Big Endian conversion
- 1 --> Little/Big Endian conversion mode is «Address Coherency»
- 2 --> Little/Big Endian conversion mode is «Data Coherency»
- 3 --> Little/Big Endian conversion mode is «bytes translation with no swapping» (only applies to 1,2 or 3 byte-data)

PCI Data (on DMAs PCI read /VME write) or VME data (on DMAs VME read /PCI write) have their bytes re-ordered according the Big/Little Endian conversion mode programmed into field \$VME_SLVx_LEBE[1:0]. Refer to 'ENDIAN CONVERSIONS' on page 169

Finally, in the case where both Channels are active, it is possible for any one channel, to interleave its own DMA blocks with those of the other Channel

\$DMA_CHNO_MIXAGE [0b0] @CC

0 -->Channel 0 is not allowed to interleave its blocks with those of Channel 1. Must wait until Channel 1 DMA is finished.

1 -->Channel 0 is allowed to interleave its blocks with those of Channel 1.

\$DMA_CHN1_MIXAGE [0b0] @DC

0 -->Channel 1 is not allowed to interleave its blocks with those of Channel 0. Must wait until Channel 0 DMA is finished.

1 -->Channel 1 is allowed to interleave its blocks with those of Channel 0.

Some applications are requiring that, on the VMEbus side, all data to be transferred to the same VME fixed address, i.e.: all VME cycles must start at the same address: initial value of DMA_CHN0_ADDVME or DMA_CHN1_ADDVME.

ALMA2f is providing a programmable bit allowing for such type of application:

\$DMA_CHN0_NOINCR	[0b0]	@CC
\$DMA_CHN1_NOINCR	[0b0]	@DC

0 -->Normal DMA is required on Channel 0/Channel 1
 1 -->VME address is not augmented by 4 during DMA

In the case of a PCI read /VME write DMA only, ALMA-V64 features a mode called «Turbo mode» allowing each DMA block to be transferred via a single PCI burst whose size is equal to the DMA block byte count (Turbo mode enabled), instead of performing a suite of 8-data burst transactions (Turbo mode disabled).

This brings some performance improvement but increases the ALMA2f bandwidth consumption. Notably, this mode prevents other bus masters to utilize the PCI bus when ALMA2f stops reading data (while it is flushing its FIFO to the VMEbus at the slower speed of that bus). This mode is controlled by the following programming bits.

\$DMA_CHN0_TURBO	[0b0]	@CC
\$DMA_CHN1_TURBO	[0b0]	@DC

0 -->Turbo mode disabled on Channel 0/Channel 1
 1 -->Turbo mode enabled on Channel 0/Channel 1

8.3 DMA Operation Timing

ALMA2f will attempt to start a DMA type of transfer on one or both channels, when the software writes a one into the bit 0 of the Channel Control Registers:

\$DMA_CHNO_START [0x00] @CC

bit written to 1: ALMA2f is required to start a DMA on Channel 0
bit written to 0: no action (DMA continues normally)

\$DMA_CHN1_START [0x00] @DC

bit written to 1: ALMA2f is required to start a DMA on Channel 1
bit written to 0: no action (DMA continues normally)

In order to perform its DMA, ALMA2f must get the ownership of both VMEbus and PCI bus.

It starts first to request the VMEbus, when granted, it then requests the PCI bus, and starts, as soon it gets the PCI bus, transferring its first DMA block: DMA_CHN0_BLOCSIZE[7:0] is decremented as data phases are acknowledged on both VME and PCI buses. When DMA_CHN0_BLOCSIZE[7:0] count is exhausted, the block is then fully transferred and \$DMA_CHN0_XFRSIZE[21:0] is decremented by the amount of DMA_CHN0_BLOCSIZE[7:0] reflecting the new amount of VME data cycles remaining to perform. The process will repeat until DMA_CHN0_XFRSIZE[21:0] count is exhausted. At that point, the end of DMA event (if not masked) is recorded into the Interrupt Status Register @E8 (control signal DMA_seq_finish0 is raised) and an interrupt to the PCI may be signalled (see chapter 6.4 "Interrupt sources translated to an interrupt to PCI" on page 153).

When a transfer error is detected on either buses, control signals DMA_seq_pcifail0, DMA_seq_pcifail1 are raised for a PCI bus error on Channel 0/1 and DMA_seq_vmefail0, DMA_seq_vmefail1 are raised for a VMEbus error. The abnormal termination events are recorded into the Error Status Register @6C and also (if not masked) into the Interrupt Status Register @E8, and an interrupt to the PCI may be signaled (see chapter Chapter 7. "ERROR HANDLING" on page 157 and chapter 6.4 "Interrupt sources translated to an interrupt to PCI" on page 153).

Chapter 9. ENDIAN CONVERSIONS

The VMEbus bytes are ordered using the Big Endian convention while the Little Endian's is used for the PCI bus.

ALMA2f automatically performs endian conversions on data exchanged between buses.

The mode in which the endian conversion is processed can be programmed into the Mapping Table Little/Big Endian conversion mode[1:0] field for PCI accesses or into the VME Slave Channel 0-7 Control registers (field VME_SLV0_LEBE[1:0])

Below are described the Endian conversion modes used by ALMA2f.

00 «No conversion» mode

Bytes are passed as is from one bus to another. Address is not affected.

01 «Address Coherency» mode.

Data bytes are swapped.

VME address is not affected (A01 bit and LWORD* signal are kept as is).

10 «Data Coherency» mode.

Data bytes ordering is not changed. (on writes, PCI MSB is aligned on VME MSB, and vice-versa on reads). The VME address obtained after translation is modified (A01 bit and LWORD*) such a way it is consistent with the byte address in the Big Endian convention (PCI address 2 msb are «XORed» with binary 11).

11 «Byte translation with no swapping» mode.

Bytes are translated (no swapping). Done only when data size is 4 bytes.

9.1 VME data Big Endian conversion to Little Endian

These Endian conversions are done on the VME data upon VME writes to the PCI bus or to ALMA2f registers or upon PCI reads from the VMEbus.

Table B.1: VME data Big to Little Endian conversions

VME signals				VMEbus data				ENDIAN CONVERSION				PCI bus data					
DS1*	DS0*	A01	LWORD*	D31:24	D23:16	D15:8	D7:0	[31:24]	[23:16]	[15:8]	[7:0]	PCI Byte Enables[3:0] (complemented)				PCI Address [1:0]	
MODE «No Conversion»																	
0	0	0	0	BYTE0	BYTE1	BYTE2	BYTE3	BYTE0	BYTE1	BYTE2	BYTE3	1	1	1	1	0	0
0	1	0	0	BYTE0	BYTE1	BYTE2		BYTE0	BYTE1	BYTE2		1	1	1	0	0	0
1	0	0	0		BYTE1	BYTE2	BYTE3		BYTE1	BYTE2	BYTE3	0	1	1	1	0	1
0	0	1	0		BYTE1	BYTE2			BYTE1	BYTE2		0	1	1	0	0	1
0	0	0	1			BYTE0	BYTE1	BYTE0	BYTE1			1	1	0	0	0	0
0	0	1	1			BYTE2	BYTE3			BYTE2	BYTE3	0	0	1	1	1	0
0	1	0	1			BYTE0		BYTE0				1	0	0	0	0	0
1	0	0	1				BYTE1		BYTE1			0	1	0	0	0	1
0	1	1	1			BYTE2				BYTE2		0	0	1	0	1	0
1	0	1	1				BYTE3				BYTE3	0	0	0	1	1	1
MODE «Address Coherency»																	
0	0	0	0	BYTE0	BYTE1	BYTE2	BYTE3	BYTE3	BYTE2	BYTE1	BYTE0	1	1	1	1	0	0
0	1	0	0	BYTE0	BYTE1	BYTE2			BYTE2	BYTE1	BYTE0	0	1	1	1	0	0
1	0	0	0		BYTE1	BYTE2	BYTE3	BYTE3	BYTE2	BYTE1		1	1	1	0	0	1
0	0	1	0		BYTE1	BYTE2			BYTE2	BYTE1		0	1	1	0	0	1
0	0	0	1			BYTE0	BYTE1			BYTE1	BYTE0	0	0	1	1	0	0
0	0	1	1			BYTE2	BYTE3	BYTE3	BYTE2			1	1	0	0	1	0
0	1	0	1			BYTE0					BYTE0	0	0	0	1	0	0
1	0	0	1				BYTE1			BYTE1		0	0	1	0	0	1
0	1	1	1			BYTE2			BYTE2			0	1	0	0	1	0
1	0	1	1				BYTE3	BYTE3				1	0	0	0	1	1
MODE «Data Coherency»																	
0	0	0	0	BYTE0	BYTE1	BYTE2	BYTE3	BYTE0	BYTE1	BYTE2	BYTE3	1	1	1	1	0	0
0	1	0	0	BYTE0	BYTE1	BYTE2		BYTE0	BYTE1	BYTE2		1	1	1	0	0	1
1	0	0	0		BYTE1	BYTE2	BYTE3		BYTE1	BYTE2	BYTE3	0	1	1	1	0	0
0	0	1	0		BYTE1	BYTE2			BYTE1	BYTE2		0	1	1	0	0	1
0	0	0	1			BYTE0	BYTE1	BYTE0	BYTE1			1	1	0	0	1	0
0	0	1	1			BYTE2	BYTE3			BYTE2	BYTE3	0	0	1	1	0	0
0	1	0	1			BYTE0		BYTE0				1	0	0	0	1	1
1	0	0	1				BYTE1		BYTE1			0	1	0	0	1	0
0	1	1	1			BYTE2				BYTE2		0	0	1	0	0	1
1	0	1	1				BYTE3				BYTE3	0	0	0	1	0	0
MODE «Bytes Translation with No Swapping»																	
0	0	0	0	BYTE0	BYTE1	BYTE2	BYTE3	BYTE0	BYTE1	BYTE2	BYTE3	1	1	1	1	0	0
0	1	0	0	BYTE0	BYTE1	BYTE2			BYTE0	BYTE1	BYTE2	0	1	1	1	0	0
1	0	0	0		BYTE1	BYTE2	BYTE3	BYTE1	BYTE2	BYTE3		1	1	1	0	0	1
0	0	1	0		BYTE1	BYTE2			BYTE1	BYTE2		0	1	1	0	0	1
0	0	0	1			BYTE0	BYTE1			BYTE0	BYTE1	0	0	1	1	0	0
0	0	1	1			BYTE2	BYTE3	BYTE2	BYTE3			1	1	0	0	1	0
0	1	0	1			BYTE0					BYTE0	0	0	0	1	0	0
1	0	0	1				BYTE1			BYTE1		0	0	1	0	0	1
0	1	1	1			BYTE2			BYTE2			0	1	0	0	1	0
1	0	1	1				BYTE3	BYTE3				1	0	0	0	1	1

9.2 PCI data Little Endian conversion to Big Endian

These endian conversions are done on the PCI data upon PCI writes to the VMEbus or upon VME reads from the PCI bus.

Note that no conversion is required when ALMA2f registers are read from the PCI bus since ALMA2f register set is mapped in the bridge already using the Little Endian byte ordering convention.

Table B.2: PCI data Little to Big Endian conversions

PCI address [1:0]	PCI Byte Enables[3:0] (complemented)	PCI bus data				ENDIAN CONVERSION				VMEbus data				VME signals			
		[31:24]	[23:16]	[15:8]	[7:0]	D31:24	D23:16	D15:8	D7:0	D31:24	D23:16	D15:8	D7:0	DS1*	DS0*	A01	LWORD*
MODE «No Conversion»																	
00	1 1 1 1	BYTE3	BYTE2	BYTE1	BYTE0	BYTE3	BYTE2	BYTE1	BYTE0	0	0	0	0	0	0	0	0
00	1 1 1 0	BYTE3	BYTE2	BYTE1		BYTE3	BYTE2	BYTE1		0	1	0	0	0	0	0	0
01	0 1 1 1		BYTE2	BYTE1	BYTE0		BYTE2	BYTE1	BYTE0	1	0	0	0	0	0	0	0
01	0 1 1 0		BYTE2	BYTE1			BYTE2	BYTE1		0	0	1	0	0	0	0	0
00	1 1 0 0	BYTE3	BYTE2					BYTE3	BYTE2	0	0	0	1	0	0	0	0
10	0 0 1 1			BYTE1	BYTE0			BYTE1	BYTE0	0	0	1	1	0	0	0	0
00	1 0 0 0	BYTE3						BYTE3		0	1	0	1	0	0	0	0
01	0 1 0 0		BYTE2						BYTE2	1	0	0	1	0	0	0	0
10	0 0 1 0			BYTE1					BYTE1	0	1	1	1	0	0	0	0
11	0 0 0 1				BYTE0				BYTE0	1	0	1	1	0	0	0	0
00	1 0 1 1	BYTE3		BYTE1	BYTE0	BYTE3		BYTE1	BYTE0	0	0	0	0	0	0	0	0
00	1 1 0 1	BYTE3	BYTE2		BYTE0	BYTE3	BYTE2		BYTE0	0	0	0	0	0	0	0	0
00	1 0 0 1	BYTE3			BYTE0	BYTE3			BYTE0	0	0	0	0	0	0	0	0
00	1 0 1 0	BYTE3		BYTE1		BYTE3		BYTE1		0	1	0	0	0	0	0	0
01	0 1 0 1		BYTE2		BYTE0		BYTE2		BYTE0	1	0	0	0	0	0	0	0
MODE «Address Coherency»																	
00	1 1 1 1	BYTE3	BYTE2	BYTE1	BYTE0	BYTE0	BYTE1	BYTE2	BYTE3	0	0	0	0	0	0	0	0
00	0 1 1 1		BYTE2	BYTE1	BYTE0	BYTE0	BYTE1	BYTE2		0	1	0	0	0	0	0	0
01	1 1 1 0	BYTE3	BYTE2	BYTE1			BYTE1	BYTE2	BYTE3	1	0	0	0	0	0	0	0
01	0 1 1 0		BYTE2	BYTE1			BYTE1	BYTE2		0	0	1	0	0	0	0	0
00	0 0 1 1			BYTE1	BYTE0			BYTE0	BYTE1	0	0	0	1	0	0	0	0
10	1 1 0 0	BYTE3	BYTE2					BYTE2	BYTE3	0	0	1	1	0	0	0	0
00	0 0 0 1				BYTE0			BYTE0		0	1	0	1	0	0	0	0
01	0 0 1 0			BYTE1					BYTE1	1	0	0	1	0	0	0	0
10	0 1 0 0		BYTE2					BYTE2		0	1	1	1	0	0	0	0
11	1 0 0 0	BYTE3							BYTE3	1	0	1	1	0	0	0	0
00	1 0 1 1	BYTE3		BYTE1	BYTE0	BYTE0	BYTE1		BYTE3	0	0	0	0	0	0	0	0
00	1 1 0 1	BYTE3	BYTE2		BYTE0	BYTE0		BYTE2	BYTE3	0	0	0	0	0	0	0	0
00	1 0 0 1	BYTE3			BYTE0	BYTE0			BYTE3	0	0	0	0	0	0	0	0
00	0 1 0 1		BYTE2		BYTE0	BYTE0		BYTE2		0	1	0	0	0	0	0	0
01	1 0 1 0	BYTE3		BYTE1				BYTE1	BYTE3	1	0	0	0	0	0	0	0



PCI address [1:0]	PCI Byte Enables[3:0] (complemented)	PCI bus data				PCI bus data converted				VME signals			
		[31:24]	[23:16]	[15:8]	[7:0]	D31:24	D23:16	D15:8	D7:0	DS1*	DS0*	A01	LWORD*
MODE «Data Coherency»													
0 0	1 1 1 1	BYTE3	BYTE2	BYTE1	BYTE0	BYTE3	BYTE2	BYTE1	BYTE0	0	0	0	0
0 1	1 1 1 0	BYTE3	BYTE2	BYTE1		BYTE3	BYTE2	BYTE1		0	1	0	0
0 0	0 1 1 1		BYTE2	BYTE1	BYTE0		BYTE2	BYTE1	BYTE0	1	0	0	0
0 1	0 1 1 0		BYTE2	BYTE1			BYTE2	BYTE1		0	0	1	0
1 0	1 1 0 0		BYTE2					BYTE3	BYTE2	0	0	0	1
0 0	0 0 1 1			BYTE1	BYTE0			BYTE1	BYTE0	0	0	1	1
1 1	1 0 0 0							BYTE3		0	1	0	1
1 0	0 1 0 0		BYTE2						BYTE2	1	0	0	1
0 1	0 0 1 0			BYTE1				BYTE1		0	1	1	1
0 0	0 0 0 1				BYTE0				BYTE0	1	0	1	1
0 0	1 0 1 1	BYTE3		BYTE1	BYTE0	BYTE3		BYTE1	BYTE0	0	0	0	0
0 0	1 1 0 1	BYTE3	BYTE2		BYTE0	BYTE3	BYTE2		BYTE0	0	0	0	0
0 0	1 0 0 1	BYTE3			BYTE0	BYTE3			BYTE0	0	0	0	0
0 1	1 0 1 0	BYTE3		BYTE1		BYTE3		BYTE1		0	1	0	0
0 0	0 1 0 1		BYTE2		BYTE0		BYTE2		BYTE0	1	0	0	0

MODE «Bytes Translation with No Swapping»

0 0	1 1 1 1	BYTE3	BYTE2	BYTE1	BYTE0	BYTE3	BYTE2	BYTE1	BYTE0	0	0	0	0
0 0	0 1 1 1		BYTE2	BYTE1	BYTE0	BYTE2	BYTE1	BYTE0		0	1	0	0
0 1	1 1 1 0	BYTE3	BYTE2	BYTE1			BYTE3	BYTE2	BYTE1	1	0	0	0
0 1	0 1 1 0		BYTE2	BYTE1			BYTE2	BYTE1		0	0	1	0
0 0	0 0 1 1			BYTE1	BYTE0			BYTE1	BYTE0	0	0	0	1
1 0	1 1 0 0	BYTE3	BYTE2					BYTE3	BYTE2	0	0	1	1
0 0	0 0 0 1				BYTE0			BYTE0		0	1	0	1
0 1	0 0 1 0			BYTE1					BYTE1	1	0	0	1
1 0	0 1 0 0		BYTE2					BYTE2		0	1	1	1
1 1	1 0 0 0	BYTE3							BYTE3	1	0	1	1
0 0	1 0 1 1	BYTE3		BYTE1	BYTE0	BYTE3		BYTE1	BYTE0	0	0	0	0
0 0	1 1 0 1	BYTE3	BYTE2		BYTE0	BYTE3	BYTE2		BYTE0	0	0	0	0
0 0	1 0 0 1	BYTE3			BYTE0	BYTE3			BYTE0	0	0	0	0
0 0	0 1 0 1		BYTE2		BYTE0		BYTE2		BYTE0	0	1	0	0
0 1	1 0 1 0	BYTE3		BYTE1			BYTE3		BYTE1	1	0	0	0

PCI Interrupt Acknowledge access («No Conversion» mode)

0 0 0 1				BYTE0				BYTE0	1	0	0	1
0 0 1 0			BYTE1					BYTE1	1	0	0	1
0 1 0 0		BYTE2						BYTE2	1	0	0	1
1 0 0 0	BYTE3							BYTE3	1	0	0	1

Document Revision



Date	Revision	Description
March13, 2009	0.1	Original version
Sept 30, 2009	1.0	Update Registers

© Copyright International Business Machines Corporation,2003

All Rights Reserved

Printed in the United States of America 12-03

The following are trademarks or registered of International Business Machines Corporation in the United States, or other countries, or both:

IBM the IBM Logo

IEEE is a registered trademark TM in the United States, of the Institute of Electrical and Electronics Engineers. For further information, see <http://www.ieee.org>.

Other company, product and service names may be trademarks or service marks of others.

All information contained in this document is subject to change without notice. The products described in this document are NOT intended for use in applications such as implantation, life support, or other hazardous uses where malfunction could result in death, bodily injury, or catastrophic property damage. The information contained in this document does not affect or change IBM product specifications or warranties. Nothing in this document shall operate as an express or implied license or indemnity under the intellectual property rights of IBM or third parties.

All information contained in this document was obtained in specific environments, and is presented as an illustration. The results obtained in other operating environments may vary.

THE INFORMATION CONTAINED IN THIS DOCUMENT IS PROVIDED ON AN "AS IS" BASIS. In no event will IBM be liable for damages arising directly or indirectly from any use of the information contained in this document.

IBM Microelectronics Division
2070 Route 52, Bldg.330
Hopewell Junction, NY 12533-6351

The IBM home page can be found at: <http://www.ibm.com>

Keep in touch with the fast pace of developments within IBM Microelectronics through news summaries and technical updates delivered electronically at [ibm.com /chips/techemail](http://ibm.com/chips/techemail)

MAILING ADDRESS

Kontron Modular Computers S.A.S.
150 rue Marcelin Berthelot - BP 244
ZI TOULON EST
83078 TOULON CEDEX - France

TELEPHONE AND E-MAIL

+33 (0) 4 98 16 34 00
sales@kontron.com
support-kom-sa@kontron.com

For further information about other Kontron products, please visit our Internet web site:
www.kontron.com.