

» User Guide «

CP6001

R1 and R2 Versions

**6U CompactPCI Processor Board based on
the Intel® Core™ Duo Processor and
the Intel® Core™2 Duo Processor with
the Intel® 945GM Express Chipset**

Doc. ID: 36643, Rev. 3.0
December 7, 2010



Revision History

Publication Title:		CP6001: 6U CompactPCI Processor Board based on the Intel® Core™ Duo Processor and the Intel® Core™2 Duo Processor with the Intel® 945GM Express Chipset
Doc. ID:		36643
Rev.	Brief Description of Changes	Date of Issue
1.0	Initial issue	20-Dec-2007
2.0	General update; removed description for the R3 version	19-Dec-2008
3.0	Removed Appendix B, CP-RIO6-001 Rear I/O Module	7-Dec-2010

Imprint

Kontron Modular Computers GmbH may be contacted via the following:

MAILING ADDRESS

Kontron Modular Computers GmbH
 Sudetenstraße 7
 D - 87600 Kaufbeuren Germany

TELEPHONE AND E-MAIL

+49 (0) 800-SALESKONTRON
 sales@kontron.com

For further information about other Kontron products, please visit our Internet web site: www.kontron.com.

Disclaimer

Copyright © 2010 Kontron AG. All rights reserved. All data is for information purposes only and not guaranteed for legal purposes. Information has been carefully checked and is believed to be accurate; however, no responsibility is assumed for inaccuracies. Kontron and the Kontron logo and all other trademarks or registered trademarks are the property of their respective owners and are recognized. Specifications are subject to change without notice.



Table of Contents

<i>Revision History</i>	<i>ii</i>
<i>Imprint</i>	<i>ii</i>
<i>Disclaimer</i>	<i>ii</i>
<i>Table of Contents</i>	<i>iii</i>
<i>List of Tables</i>	<i>ix</i>
<i>List of Figures</i>	<i>xiii</i>
<i>Proprietary Note</i>	<i>xv</i>
<i>Trademarks</i>	<i>xv</i>
<i>Environmental Protection Statement</i>	<i>xv</i>
<i>Explanation of Symbols</i>	<i>xvi</i>
<i>For Your Safety</i>	<i>xvii</i>
<i>High Voltage Safety Instructions</i>	<i>xvii</i>
<i>Special Handling and Unpacking Instructions</i>	<i>xvii</i>
<i>General Instructions on Usage</i>	<i>xviii</i>
<i>Two Year Warranty</i>	<i>xix</i>
1. Introduction	1 - 3
1.1 <i>Board Overview</i>	1 - 3
1.2 <i>Board-Specific Information</i>	1 - 4
1.3 <i>System Expansion Capabilities</i>	1 - 5
1.3.1 <i>PMC/CCPMC Module</i>	1 - 5
1.3.2 <i>CP6001-MK2.5SATA Assembly Kit</i>	1 - 5
1.3.3 <i>Rear I/O Module</i>	1 - 5
1.4 <i>Board Diagrams</i>	1 - 6
1.4.1 <i>Functional Block Diagram</i>	1 - 6
1.4.2 <i>Front Panels</i>	1 - 7
1.4.3 <i>Board Layout</i>	1 - 8
1.5 <i>Technical Specification</i>	1 - 11
1.6 <i>Kontron Software Support</i>	1 - 16
1.7 <i>Standards</i>	1 - 17
1.8 <i>Related Publications</i>	1 - 18
2. Functional Description	2 - 3

2.1	CPU, Memory and Chipset	2 - 3
2.1.1	CPU	2 - 3
2.1.2	Memory	2 - 5
2.1.3	Intel® 945GM Express Chipset Overview	2 - 5
2.1.4	Mobile Intel® 945GM Express Chipset GMCH	2 - 5
2.1.5	I/O Controller Hub (ICH7R)	2 - 6
2.2	Peripherals	2 - 6
2.2.1	Timer	2 - 6
2.2.2	Watchdog Timer	2 - 6
2.2.3	Battery	2 - 7
2.2.4	Reset	2 - 7
2.2.5	SMBus Devices	2 - 8
2.2.6	Thermal Management/System Monitoring	2 - 8
2.2.7	Serial EEPROM	2 - 8
2.2.8	FLASH Memory	2 - 9
2.2.8.1	BIOS FLASH (Firmware Hub)	2 - 9
2.2.8.2	USB 2.0 NAND Flash Module	2 - 9
2.2.8.3	CompactFlash Controller	2 - 9
2.2.9	Trusted Platform Module (TPM) 1.2	2 - 10
2.3	Board Interfaces	2 - 10
2.3.1	Front Panel LEDs	2 - 10
2.3.1.1	IPMI LEDs and Hot Swap LED	2 - 10
2.3.1.2	Watchdog LED and Overtemperature LED	2 - 11
2.3.1.3	General Purpose LEDs	2 - 12
2.3.2	USB Interfaces	2 - 13
2.3.2.1	Front Panel USB Connectors J9 and J10	2 - 14
2.3.2.2	Onboard USB NAND Flash Connector J19	2 - 14
2.3.3	Graphics Controller	2 - 15
2.3.4	COM Ports	2 - 17
2.3.5	Gigabit Ethernet	2 - 18
2.3.6	Extension Connector J14	2 - 19
2.3.7	Serial ATA Interface	2 - 19
2.3.7.1	Serial ATA Connector J18	2 - 19
2.3.7.2	2.5" SATA HDD Extension Connector J20	2 - 20

2.3.8	<i>PMC Interface</i>	2 - 21
2.3.8.1	<i>PMC Connectors J21, J22 and J23 Pinouts</i>	2 - 22
2.3.9	<i>Debug Interface</i>	2 - 24
2.3.10	<i>CompactPCI Interface</i>	2 - 24
2.3.10.1	<i>System Master Configuration</i>	2 - 24
2.3.10.2	<i>Peripheral Master Configuration (Passive Mode)</i>	2 - 24
2.3.10.3	<i>Packet Switching Backplane (PICMG 2.16)</i>	2 - 24
2.3.10.4	<i>Hot Swap Support</i>	2 - 25
2.3.10.5	<i>Power Ramping</i>	2 - 25
2.3.10.6	<i>Precharge</i>	2 - 25
2.3.10.7	<i>Handle Switch</i>	2 - 25
2.3.10.8	<i>ENUM# Interrupt</i>	2 - 25
2.3.10.9	<i>Hot Swap LED</i>	2 - 25
2.3.11	<i>CompactPCI Bus Connector</i>	2 - 26
2.3.11.1	<i>CompactPCI Connector Keying</i>	2 - 26
2.3.11.2	<i>CompactPCI Connectors J1 and J2 Pinouts</i>	2 - 27
2.3.11.3	<i>CompactPCI Rear I/O Connectors J3-J5 and Pinouts</i>	2 - 31
2.3.11.4	<i>Rear I/O Configuration</i>	2 - 35
2.4	<i>Intelligent Platform Management Interface</i>	2 - 36
2.4.1	<i>Technical Background of IPMI</i>	2 - 36
2.4.2	<i>IPMI Glossary</i>	2 - 37
2.4.3	<i>IPMI Implementation on the CP6001</i>	2 - 38
2.4.3.1	<i>Sensors Implemented on the CP6001</i>	2 - 39
2.4.4	<i>Data Repositories</i>	2 - 40
3.	<i>Installation</i>	3 - 3
3.1	<i>Safety Requirements</i>	3 - 3
3.2	<i>Initial Installation Procedures</i>	3 - 4
3.3	<i>Standard Removal Procedures</i>	3 - 5
3.4	<i>Hot Swap Procedures</i>	3 - 6
3.4.1	<i>System Master Hot Swap</i>	3 - 6
3.4.2	<i>Peripheral Hot Swap Procedure</i>	3 - 6
3.5	<i>Installation of CP6001 Peripheral Devices</i>	3 - 8



3.5.1	USB Device Installation	3 - 8
3.5.2	Rear I/O Device Installation	3 - 8
3.5.3	Battery Replacement	3 - 9
3.5.4	Hard Disk Installation	3 - 9
3.6	PMC/CCPMC Module Installation	3 - 10
3.7	Software Installation	3 - 10

4. Configuration **4 - 3**

4.1	Jumper Description	4 - 3
4.1.1	Clearing BIOS CMOS Setup	4 - 3
4.1.2	COM2 Termination Jumper Settings	4 - 3
4.1.3	Shorting Chassis GND (Shield) to Logic GND	4 - 4
4.1.4	BIOS Firmware Hub Flash Configuration	4 - 4
4.1.5	M66EN Configuration	4 - 4
4.2	Write Protection for Non-Volatile Memory Devices	4 - 5
4.3	I/O Address Map	4 - 6
4.4	CP6001-Specific Registers	4 - 7
4.4.1	Status Register 0	4 - 7
4.4.2	Status Register 1	4 - 8
4.4.3	Control Register 0	4 - 9
4.4.4	Control Register 1	4 - 9
4.4.5	Device Protection Register	4 - 10
4.4.6	Reset Status Register	4 - 11
4.4.7	Board Interrupt Configuration Register	4 - 12
4.4.8	Board ID Register	4 - 13
4.4.9	Board and PLD Revision Register	4 - 13
4.4.10	Geographic Addressing Register	4 - 13
4.4.11	Delay Timer Register	4 - 14
4.4.12	Watchdog Timer Control Register	4 - 15
4.4.13	LED Configuration Register	4 - 17
4.4.14	LED Control Register	4 - 18
4.4.15	General Purpose Data Register	4 - 19
4.4.16	General Purpose Control Register	4 - 19

4.5	<i>BMC-Specific Registers</i>	4 - 20
4.5.1	<i>IPMI Boot Configuration Register</i>	4 - 20
4.5.2	<i>IPMI Controller Configuration Register</i>	4 - 21
4.5.3	<i>IPMI Controller Status Register</i>	4 - 22
4.5.4	<i>IPMI Reset Status Register</i>	4 - 23
4.5.5	<i>IPMI Keyboard Control Style Interface</i>	4 - 24
5.	<i>Power Considerations</i>	5 - 3
5.1	<i>System Power</i>	5 - 3
5.1.1	<i>CP6001 Baseboard</i>	5 - 3
5.1.2	<i>Backplane</i>	5 - 4
5.1.3	<i>Power Supply Units</i>	5 - 4
5.1.3.1	<i>Start-Up Requirement</i>	5 - 4
5.1.3.2	<i>Power-Up Sequence</i>	5 - 5
5.1.3.3	<i>Tolerance</i>	5 - 5
5.1.3.4	<i>Regulation</i>	5 - 5
5.2	<i>Power Consumption</i>	5 - 6
5.2.1	<i>Power Consumption of the CP6001 Accessories</i>	5 - 8
5.2.2	<i>Power Consumption of the Gigabit Ethernet Controller</i>	5 - 8
5.3	<i>Start-Up Currents of the CP6001</i>	5 - 8
5.4	<i>Power Available for PMC Devices</i>	5 - 9
6.	<i>Thermal Considerations</i>	6 - 3
6.1	<i>Board Internal Thermal Monitoring</i>	6 - 3
6.1.1	<i>Placement of the Temperature Sensors</i>	6 - 3
6.2	<i>Processor Thermal Monitoring and Regulation</i>	6 - 4
6.2.1	<i>Digital Thermal Sensor (DTS)</i>	6 - 4
6.2.2	<i>Thermal Diode Sensor</i>	6 - 4
6.2.3	<i>Thermal Monitor 1 (TM1)</i>	6 - 4
6.2.4	<i>Thermal Monitor 2 (TM2)</i>	6 - 5
6.2.5	<i>TM1 and TM2 Operation</i>	6 - 5
6.2.6	<i>Catastrophic Cooling Failure Sensor</i>	6 - 5
6.3	<i>External Thermal Regulation</i>	6 - 6



6.3.1	<i>Operational Limits for the R1 Version</i>	6 - 8
6.3.2	<i>Operational Limits for the R2 Version</i>	6 - 9
6.3.3	<i>Peripherals</i>	6 - 10

A. CP6001-MK2.5SATA Assembly Kit A - 3

A.1	<i>CP6001-EXT-SATA Module Overview</i>	A - 3
A.2	<i>Technical Specifications</i>	A - 3
A.3	<i>CP6001-EXT-SATA Functional Block Diagram</i>	A - 3
A.4	<i>CP6001-EXT-SATA Module Layout</i>	A - 4
A.5	<i>Module Interfaces</i>	A - 5
A.5.1	<i>Board-to-Board Connectors J1</i>	A - 5
A.5.2	<i>SATA Connector J2</i>	A - 6



List of Tables

1-1	<i>CP6001 Main Specifications</i>	1 - 11
1-2	<i>Standards for the CP6001 R1 and R2 versions</i>	1 - 17
1-3	<i>Additional Standards for the CP6001 R2 Version</i>	1 - 18
1-4	<i>Related Publications</i>	1 - 18
2-1	<i>Processors Supported on the CP6001</i>	2 - 4
2-2	<i>Maximum Power Dissipation of the Processors (CPU only)</i>	2 - 4
2-3	<i>CPU Frequency in the Various SpeedStep® Modes</i>	2 - 4
2-4	<i>Supported Memory Configurations</i>	2 - 5
2-5	<i>SMBus Device Addresses</i>	2 - 8
2-6	<i>EEPROM Address Map</i>	2 - 8
2-8	<i>Watchdog LED and Overtemperature LED Function</i>	2 - 11
2-7	<i>IPMI LEDs and Hot Swap LED Function</i>	2 - 11
2-9	<i>General Purpose LED Function</i>	2 - 12
2-10	<i>POST Code/Port 80</i>	2 - 13
2-11	<i>USB Con. J9 and J10 Pinout</i>	2 - 14
2-12	<i>USB NAND Flash Con. J19 Pinout</i>	2 - 14
2-13	<i>D-Sub VGA Connector J11 Pinout</i>	2 - 16
2-14	<i>Serial Con. J12 (COM1) Pinout</i>	2 - 17
2-15	<i>Pinout of GbE Con. J6, J7 and J8</i>	2 - 18
2-16	<i>SATA Connector J18 Pinout</i>	2 - 19
2-17	<i>SATA Extension Connector J20 Pinout</i>	2 - 20
2-18	<i>Onboard PCI Configuration</i>	2 - 21
2-19	<i>PMC Connectors J21 and J23 Pinouts</i>	2 - 22
2-20	<i>PMC Connectors J22 Pinout</i>	2 - 23
2-21	<i>CompactPCI Bus Connector J1 System Slot Pinout</i>	2 - 27
2-22	<i>CompactPCI Bus Connector J1 Peripheral Slot Pinout</i>	2 - 28
2-23	<i>64-bit CompactPCI Bus Connector J2 System Slot Pinout</i>	2 - 29
2-24	<i>64-bit CompactPCI Bus Connector J2 Peripheral Slot Pinout</i>	2 - 30
2-25	<i>CompactPCI Rear I/O Connector J3 Pinout</i>	2 - 31
2-26	<i>CompactPCI Rear I/O Connector J3 Signals</i>	2 - 32
2-27	<i>CompactPCI Rear I/O Connector J4 Pinout</i>	2 - 33
2-28	<i>CompactPCI Rear I/O Connector J5 Pinout</i>	2 - 34



2-29	<i>CompactPCI Rear I/O Connector J5 Signals</i>	2 - 35
2-30	<i>Processor, Chipset and General Board Supervision</i>	2 - 39
2-31	<i>Various BMC/SMC Sensors</i>	2 - 39
2-32	<i>CompactPCI Sensors</i>	2 - 39
2-33	<i>Onboard Power Supply Supervision</i>	2 - 40
2-34	<i>Onboard Voltage Sensors</i>	2 - 40
2-35	<i>Temperature Sensors</i>	2 - 40
2-36	<i>Fan Sense Sensors</i>	2 - 40
3-1	<i>ATA Channel Routing</i>	3 - 10
4-1	<i>Clearing BIOS CMOS Setup</i>	4 - 3
4-2	<i>Jumper Setting for RS-422 TXD Termination (COM2)</i>	4 - 3
4-3	<i>Jumper Setting for RS-422 RXD Termination (COM2)</i>	4 - 3
4-4	<i>BIOS Firmware Hub Flash Configuration</i>	4 - 4
4-5	<i>M66EN Configuration</i>	4 - 4
4-6	<i>Write Protection for Non-Volatile Memory Devices</i>	4 - 5
4-7	<i>I/O Address Map</i>	4 - 6
4-8	<i>Status Register 0</i>	4 - 7
4-9	<i>Status Register 1</i>	4 - 8
4-10	<i>Control Register 0</i>	4 - 9
4-11	<i>Control Register 1</i>	4 - 9
4-12	<i>Device Protection Register</i>	4 - 10
4-13	<i>Reset Status Register</i>	4 - 11
4-14	<i>Board Interrupt Configuration Register</i>	4 - 12
4-15	<i>Board ID Register</i>	4 - 13
4-16	<i>Board and PLD Revision Register</i>	4 - 13
4-17	<i>Geographic Addressing Register</i>	4 - 13
4-18	<i>Delay Timer Register</i>	4 - 14
4-19	<i>Watchdog Timer Control Register</i>	4 - 16
4-20	<i>LED Configuration Register</i>	4 - 17
4-21	<i>LED Control Register</i>	4 - 18
4-22	<i>General Purpose Data Register</i>	4 - 19
4-23	<i>General Purpose Control Register</i>	4 - 19
4-24	<i>IPMI Boot Configuration Register</i>	4 - 20
4-25	<i>IPMI Controller Configuration Register</i>	4 - 21



4-26	<i>COM Port Routing for the Firmware Update and Debugging Purposes ..</i>	4 - 22
4-27	<i>IPMI Controller Status Register</i>	4 - 22
4-28	<i>IPMI Reset Status Register</i>	4 - 23
5-1	<i>Maximum Input Power Voltage Limits</i>	5 - 3
5-2	<i>DC Operational Input Voltage Ranges</i>	5 - 3
5-3	<i>Input Voltage Characteristics</i>	5 - 5
5-4	<i>Power Consumption: CP6001 with DOS</i>	5 - 7
5-5	<i>Power Consumption: CP6001 with Linux/Win. XP in IDLE Mode</i>	5 - 7
5-6	<i>Power Consumption: CP6001 at 75% TDP</i>	5 - 7
5-7	<i>Power Consumption: CP6001 at 100% TDP</i>	5 - 7
5-8	<i>Power Consumption of CP6001 Accessories</i>	5 - 8
5-9	<i>Intel® 82573L Gigabit Ethernet Controller Power Consumption</i>	5 - 8
5-10	<i>Start-Up Currents of the CP6001</i>	5 - 8
5-11	<i>Maximum Output Power Limits</i>	5 - 9
A-1	<i>CP6001-EXT-SATA Main Specifications</i>	A - 3
A-2	<i>Board-to-Board Connector J1 Pinout</i>	A - 5
A-3	<i>SATA Connector J2 Pinout</i>	A - 6



This page has been intentionally left blank.





List of Figures

1-1	<i>CP6001 Functional Block Diagram</i>	1 - 6
1-2	<i>CP6001 Front Panels</i>	1 - 7
1-3	<i>CP6001 Board Layout – Front View – R1 Version</i>	1 - 8
1-4	<i>CP6001 Board Layout – Front View – R2 Version</i>	1 - 9
1-5	<i>CP6001 Board Layout – Reverse View</i>	1 - 10
2-1	<i>USB Con. J9 and J10</i>	2 - 14
2-2	<i>USB NAND Flash Con. J19</i>	2 - 14
2-3	<i>D-Sub VGA Con. J11</i>	2 - 16
2-4	<i>Serial Con. J12 (COM1)</i>	2 - 17
2-5	<i>Gigabit Ethernet Con. J6, J7 and J8</i>	2 - 18
2-6	<i>Extension Con. J14</i>	2 - 19
2-7	<i>SATA Con. J18</i>	2 - 19
2-8	<i>SATA Ext. Con. J20</i>	2 - 20
2-9	<i>Connecting an Onb. 2.5" SATA HDD to the CP6001-EXT-SATA Module</i>	2 - 20
2-10	<i>PMC Connectors J21, J22 and J23</i>	2 - 21
2-11	<i>CPCI Connectors J1-J5</i>	2 - 26
6-1	<i>Temperature Sensor Placement (CP6001 Top View)</i>	6 - 3
6-2	<i>Operational Limits for the R1 Version with Core™ Duo 1.2 GHz</i>	6 - 8
6-3	<i>Operational Limits for the R1 Version with Core™2 Duo 1.5 GHz</i>	6 - 8
6-4	<i>Operational Limits for the R2 Version with Core™ Duo 1.2 GHz</i>	6 - 9
6-5	<i>Operational Limits for the R2 Version with Core™2 Duo 1.5 GHz</i>	6 - 9
A-1	<i>CP6001-EXT-SATA Functional Block Diagram</i>	A - 3
A-2	<i>CP6001-EXT-SATA Module Layout</i>	A - 4
A-3	<i>SATA Connector J2</i>	A - 6



This page has been intentionally left blank.





Proprietary Note

This document contains information proprietary to Kontron. It may not be copied or transmitted by any means, disclosed to others, or stored in any retrieval system or media without the prior written consent of Kontron or one of its authorized agents.

The information contained in this document is, to the best of our knowledge, entirely correct. However, Kontron cannot accept liability for any inaccuracies or the consequences thereof, or for any liability arising from the use or application of any circuit, product, or example shown in this document.

Kontron reserves the right to change, modify, or improve this document or the product described herein, as seen fit by Kontron without further notice.

Trademarks

Kontron, the *PEP* logo and, if occurring in this manual, “CXM” are trademarks owned by Kontron, Kaufbeuren (Germany). In addition, this document may include names, company logos and trademarks, which are registered trademarks and, therefore, proprietary to their respective owners.

Environmental Protection Statement

This product has been manufactured to satisfy environmental protection requirements where possible. Many of the components used (structural parts, printed circuit boards, connectors, batteries, etc.) are capable of being recycled.

Final disposition of this product after its service life must be accomplished in accordance with applicable country, state, or local laws or regulations.



Explanation of Symbols



Caution, Electric Shock!

This symbol and title warn of hazards due to electrical shocks (> 60V) when touching products or parts of them. Failure to observe the precautions indicated and/or prescribed by the law may endanger your life/health and/or result in damage to your material.

Please refer also to the section “High Voltage Safety Instructions” on the following page.



Warning, ESD Sensitive Device!

This symbol and title inform that electronic boards and their components are sensitive to static electricity. Therefore, care must be taken during all handling operations and inspections of this product, in order to ensure product integrity at all times.

Please read also the section “Special Handling and Unpacking Instructions” on the following page.



Warning!

This symbol and title emphasize points which, if not fully understood and taken into consideration by the reader, may endanger your health and/or result in damage to your material.



Note ...

This symbol and title emphasize aspects the reader should read through carefully for his or her own advantage.



For Your Safety

Your new Kontron product was developed and tested carefully to provide all features necessary to ensure its compliance with electrical safety requirements. It was also designed for a long fault-free life. However, the life expectancy of your product can be drastically reduced by improper treatment during unpacking and installation. Therefore, in the interest of your own safety and of the correct operation of your new Kontron product, you are requested to conform with the following guidelines.

High Voltage Safety Instructions



Warning!

All operations on this device must be carried out by sufficiently skilled personnel only.



Caution, Electric Shock!

Before installing a not hot-swappable Kontron product into a system always ensure that your mains power is switched off. This applies also to the installation of piggybacks.

Serious electrical shock hazards can exist during all installation, repair and maintenance operations with this product. Therefore, always unplug the power cable and any other cables which provide external voltages before performing work.

Special Handling and Unpacking Instructions



ESD Sensitive Device!

Electronic boards and their components are sensitive to static electricity. Therefore, care must be taken during all handling operations and inspections of this product, in order to ensure product integrity at all times.

Do not handle this product out of its protective enclosure while it is not used for operational purposes unless it is otherwise protected.

Whenever possible, unpack or pack this product only at EOS/ESD safe work stations. Where a safe work station is not guaranteed, it is important for the user to be electrically discharged before touching the product with his/her hands or tools. This is most easily done by touching a metal part of your system housing.

It is particularly important to observe standard anti-static precautions when changing piggybacks, ROM devices, jumper settings etc. If the product contains batteries for RTC or memory backup, ensure that the board is not placed on conductive surfaces, including anti-static plastics or sponges. They can cause short circuits and damage the batteries or conductive circuits on the board.



General Instructions on Usage

In order to maintain Kontron's product warranty, this product must not be altered or modified in any way. Changes or modifications to the device, which are not explicitly approved by Kontron and described in this manual or received from Kontron's Technical Support as a special handling instruction, will void your warranty.

This device should only be installed in or connected to systems that fulfill all necessary technical and specific environmental requirements. This applies also to the operational temperature range of the specific board version, which must not be exceeded. If batteries are present, their temperature restrictions must be taken into account.

In performing all necessary installation and application operations, please follow only the instructions supplied by the present manual.

Keep all the original packaging material for future storage or warranty shipments. If it is necessary to store or ship the board, please re-pack it as nearly as possible in the manner in which it was delivered.

Special care is necessary when handling or unpacking the product. Please consult the special handling and unpacking instruction on the previous page of this manual.



Two Year Warranty

Kontron grants the original purchaser of Kontron's products a **TWO YEAR LIMITED HARDWARE WARRANTY** as described in the following. However, no other warranties that may be granted or implied by anyone on behalf of Kontron are valid unless the consumer has the express written consent of Kontron.

Kontron warrants their own products, excluding software, to be free from manufacturing and material defects for a period of 24 consecutive months from the date of purchase. This warranty is not transferable nor extendible to cover any other users or long-term storage of the product. It does not cover products which have been modified, altered or repaired by any other party than Kontron or their authorized agents. Furthermore, any product which has been, or is suspected of being damaged as a result of negligence, improper use, incorrect handling, servicing or maintenance, or which has been damaged as a result of excessive current/voltage or temperature, or which has had its serial number(s), any other markings or parts thereof altered, defaced or removed will also be excluded from this warranty.

If the customer's eligibility for warranty has not been voided, in the event of any claim, he may return the product at the earliest possible convenience to the original place of purchase, together with a copy of the original document of purchase, a full description of the application the product is used on and a description of the defect. Pack the product in such a way as to ensure safe transportation (see our safety instructions).

Kontron provides for repair or replacement of any part, assembly or sub-assembly at their own discretion, or to refund the original cost of purchase, if appropriate. In the event of repair, refunding or replacement of any part, the ownership of the removed or replaced parts reverts to Kontron, and the remaining part of the original guarantee, or any new guarantee to cover the repaired or replaced items, will be transferred to cover the new or repaired items. Any extensions to the original guarantee are considered gestures of goodwill, and will be defined in the "Repair Report" issued by Kontron with the repaired or replaced item.

Kontron will not accept liability for any further claims resulting directly or indirectly from any warranty claim, other than the above specified repair, replacement or refunding. In particular, all claims for damage to any system or process in which the product was employed, or any loss incurred as a result of the product not functioning at any given time, are excluded. The extent of Kontron liability to the customer shall not exceed the original purchase price of the item for which the claim exists.

Kontron issues no warranty or representation, either explicit or implicit, with respect to its products' reliability, fitness, quality, marketability or ability to fulfil any particular application or purpose. As a result, the products are sold "as is," and the responsibility to ensure their suitability for any given task remains that of the purchaser. In no event will Kontron be liable for direct, indirect or consequential damages resulting from the use of our hardware or software products, or documentation, even if Kontron were advised of the possibility of such claims prior to the purchase of the product or during any period since the date of its purchase.

Please remember that no Kontron employee, dealer or agent is authorized to make any modification or addition to the above specified terms, either verbally or in any other form, written or electronically transmitted, without the company's consent.



This page has been intentionally left blank.





Chapter

1

Introduction



This page has been intentionally left blank.





1. Introduction

1.1 Board Overview

The CP6001 is a highly integrated 6U CompactPCI CPU board based on the Intel® Core™ Duo and the Intel® Core™2 Duo microprocessors combined with the high-performance Mobile Intel® 945GM Express Chipset.

The board is capable of supporting the Intel® Core™ Duo and the Intel® Core™2 Duo processor versions in 65 nm technology with 64 kB L1 and up to 4 MB L2 cache in a 479 µFCBGA package with frequencies of 1.2 GHz and 1.5 GHz providing 533 MHz or 667 MHz front side bus speed. The CP6001 utilizes the Mobile Intel® 945GM Express Chipset as Graphics Memory Controller Hub and the ICH7R as I/O Controller Hub.

The board includes up to 4 GB of soldered, dual-channel Double Data Rate 2 (DDR2) memory. The DDR2 memory operates at 533/667 MHz, depending on the CPU. A soldered CompactFlash solution is implemented via an IDE Flash controller combined with a NAND Flash memory. The CP6001 further provides support for one optional USB 2.0 NAND Flash module.

The CP6001 offers a complete set of data, communication and multimedia interfaces, such as three Gigabit Ethernet ports (Intel® 82573L) on the front panel, two of which are switchable to rear I/O (in accordance with the PICMG CompactPCI Packet Switching Backplane Specification 2.16), one Parallel ATA interface connected to the soldered CompactFlash, two onboard Serial ATA interfaces switchable to rear I/O and two additional Serial ATA interfaces only on rear I/O, one high-resolution VGA interface (CRT), one DVI interface and one HDMI interface over rear I/O through dedicated SDVO transmitters, one PMC interface with 32-bit/66 MHz, and rear I/O with several interfaces. In addition, seven USB 2.0 ports are available on the board, two on the front panel, one onboard port for the USB 2.0 NAND Flash module, and four on rear I/O. Further interfaces include two COM ports, one RS-232 port implemented as RJ-45 connector on the front panel and routed to rear I/O, and one RS-422 port on the rear I/O. The board supports a configurable 32-bit/66 MHz, hot swap CompactPCI interface.

The CP6001 provides safety and security via a Trusted Platform Module (TPM) 1.2, two redundant firmware hubs (FWH) and Intelligent Platform Management Interface (IPMI) support.

The passively cooled CP6001 is available with E2 capabilities. The CP6001 R1 version is designed for standard application requirements in air-cooled environments and can accommodate a PMC module or an onboard 2.5" SATA HDD. The CP6001 R2 version is ruggedized for high shock and vibration environments and provides support for a conduction cooled PCI mezzanine card (CCPMC).

Designed for stability and packaged in a rugged format, the board fits into all applications situated in industrial environments, including I/O intensive applications where only one slot is available for the CPU, making it a perfect core technology for long-life applications. Components with high temperature tolerance have been selected from embedded technology programs, and therefore offer long-term availability.

The board is offered with Microsoft® Windows® XP, Windows® XP Embedded, Linux, and VxWorks operating systems. Please contact Kontron for further information concerning the operation of the CP6001 with other operating systems.



1.2 Board-Specific Information

The CP6001 is a CompactPCI single-board computer based on the Intel® Core™ Duo and the Intel® Core™2 Duo processors and specifically designed for use in highly integrated platforms with solid mechanical interfacing for a wide range of industrial environment applications.

Some of the CP6001's outstanding features are:

- Designed to support for the following processors:
 - Intel® Core™ Duo, U2500 (ULV), 1.2 GHz, 533 MHz FSB, 2 MB L2 cache
 - Intel® Core™2 Duo, L7400 (LV), 1.5 GHz, 667 MHz FSB, 4 MB L2 cache
- 479-pin µFCBGA package
- 64 kB L1 and up to 4 MB L2 cache on-die, running at CPU speed
- Intel® 945GM and Intel® 82801GR (ICH7R) chipset
- Up to 4 GB DDR2-SDRAM memory running at 533/667 MHz
- Integrated 3D high-performance VGA controller
- Analog display support for up to 2048 x 1536 pixels at 75 Hz
- Two independent digital display interfaces: DVI and HDMI/DVI, both routed to rear I/O
- Support for up to two High Definition Audio codecs on rear I/O
- 32-bit / 66 MHz CompactPCI interface in accordance with the PICMG 2.0, Rev 3.0 spec.
- PMC interface with rear I/O support and bezel cutout on front panel and PCI functionality, 32-bit/66 MHz PCI
- Three Gigabit Ethernet interfaces utilizing an x1 lane PCI Express per GbE controller
 - Two Gigabit Ethernet interfaces on the front panel switchable to rear I/O (PICMG 2.16)
 - One Gigabit Ethernet interface on the front panel
- EIDE Ultra ATA interface for soldered CompactFlash
- Four Serial ATA interfaces
 - Two onboard Serial ATA interfaces switchable to rear I/O
 - Two Serial ATA interfaces on rear I/O
- Optional mounting kit for Serial ATA 2.5" hard disk
- Up to seven USB 2.0 ports:
 - Two ports on the front panel
 - One onboard port for the USB 2.0 NAND Flash module
 - Four ports on rear I/O
- Two COM ports (RS-232 and RS-422):
 - One RS-232 port either on the front panel or on the rear I/O
 - One RS-422 port on the rear I/O
- I/O extension connector (LPC)
- 4HP, 6U CompactPCI
- AMI BIOS
- Two 1 MB onboard FWBs for redundant BIOS
- Watchdog Timer
- Real-time clock
- Jumperless board configuration
- Passive heat sink solution for forced convection cooling
- Hot swap capability: as system controller or as peripheral device
- Supports PICMG Packet Switching Backplane Specification 2.16
- Several rear I/O configurations
- Rear I/O on J3 and J5; optionally on J4
- IPMI compliant Baseboard Management Controller



1.3 System Expansion Capabilities

1.3.1 PMC/CCPMC Module

The CP6001 has one PCI-X, 32-bit/66 MHz, rear I/O capable, PMC mezzanine interface. This interface supports a wide range of available PMC/CCPMC modules with PCI interface including all of Kontron's PMC modules and provides an easy and flexible way to configure the CP6001 for various application requirements.

The CP6001 R1 version provides support for a PMC module. The CP6001 R2 version provides support for a conduction cooled PMC (CCPMC) module.

For further information concerning the PMC interface, refer to Chapter 2.3.8, PMC Interface.

1.3.2 CP6001-MK2.5SATA Assembly Kit

The CP6001 R1 version comes with an optional CP6001-MK2.5SATA assembly kit comprised of one CP6001-EXT-SATA module and the necessary components needed for mounting the module on the board. The CP6001-EXT-SATA module is required for connecting an onboard 2.5" Serial ATA HDD or SSD to the CP6001 and can be used only on the R1 version.

For further information concerning the CP6001-EXT-SATA module, refer to Appendix A.

1.3.3 Rear I/O Module

The CP6001 provides comprehensive rear I/O functionality via optionally available rear I/O modules such as the CP-RIO6-001, CP-RIO6-001-HD, CP-RIO6-001-HD-216, CP-RIO6-A, CP-RIO6-B, CP-RIO6-A216, CP-RIO6-B216, and CP-RIO6-M.

For further information, refer to the appropriate user guide.



1.4 Board Diagrams

The following diagrams provide additional information concerning board functionality and component layout.

1.4.1 Functional Block Diagram

Figure 1-1: CP6001 Functional Block Diagram

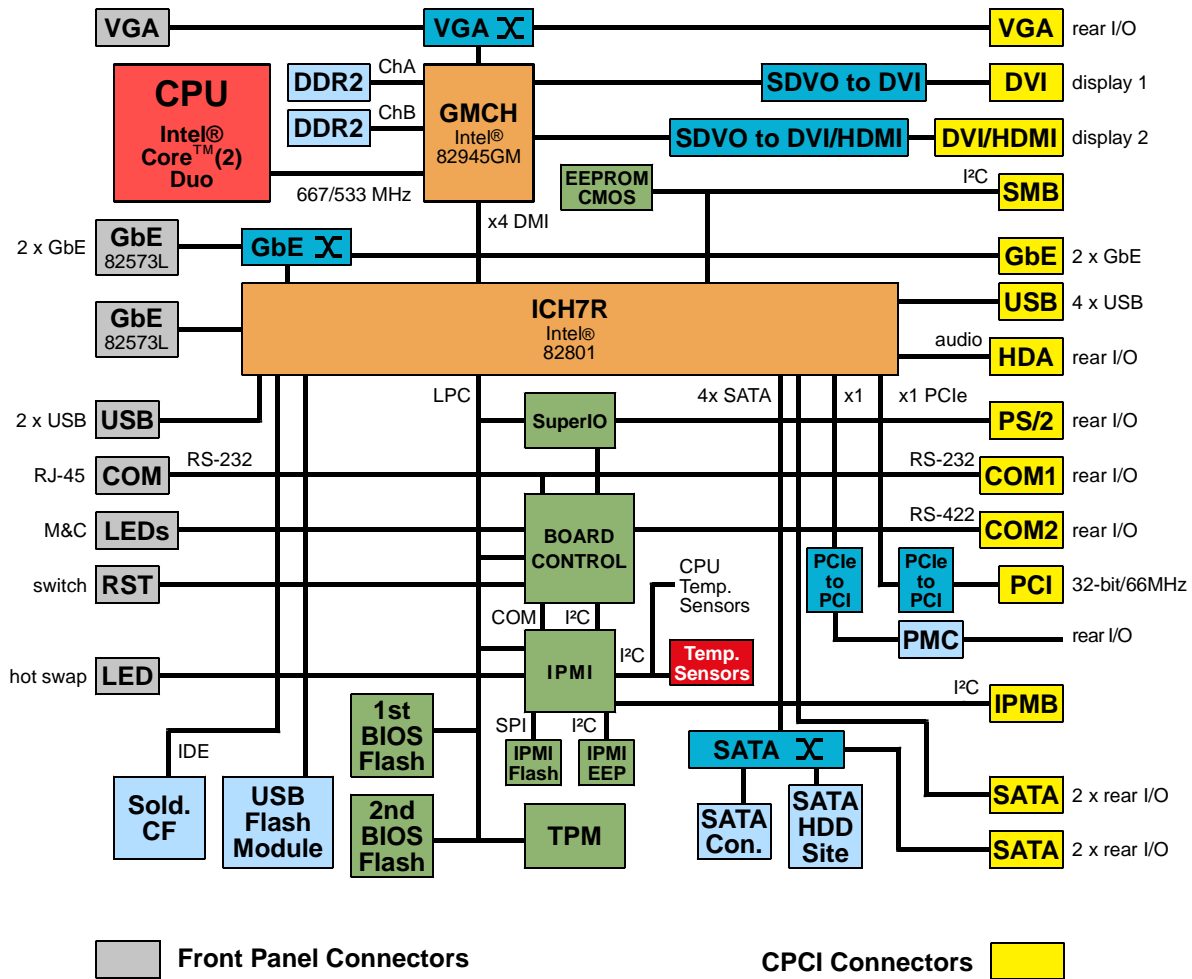



1.4.2 Front Panels

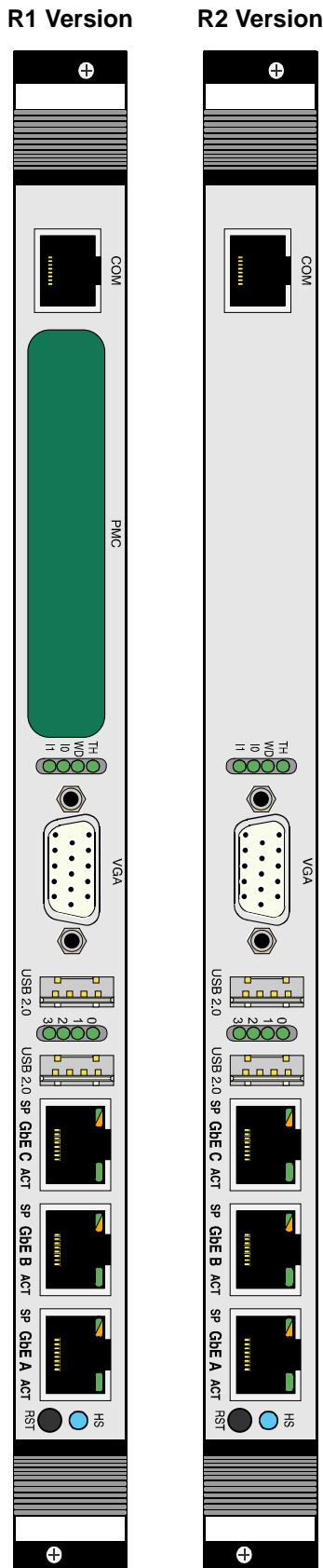

Figure 1-2: CP6001 Front Panels

Legend:

IPMI LEDs

IO/I1 (red/green): Indicate the software status of the IPMI controller

Status LEDs

WD (red/green): Watchdog Status

TH (red/green/amber): Overtemperature Status

HS (blue): Hot Swap Control

General Purpose LEDs

LED 0..3 (red/green/amber): General Purpose/POST code

Integral Ethernet LEDs

ACT (green): Ethernet Link/Activity

SPEED (green/orange): Ethernet Speed

SPEED ON (orange): 1000 Mbit

SPEED ON (green): 100 Mbit

SPEED OFF: 10 Mbit



Note ...

If the General Purpose LEDs are lit red during boot-up, a failure is indicated before the BIOS has started.

For further information, please contact Kontron.

1.4.3 Board Layout

Figure 1-3: CP6001 Board Layout – Front View – R1 Version

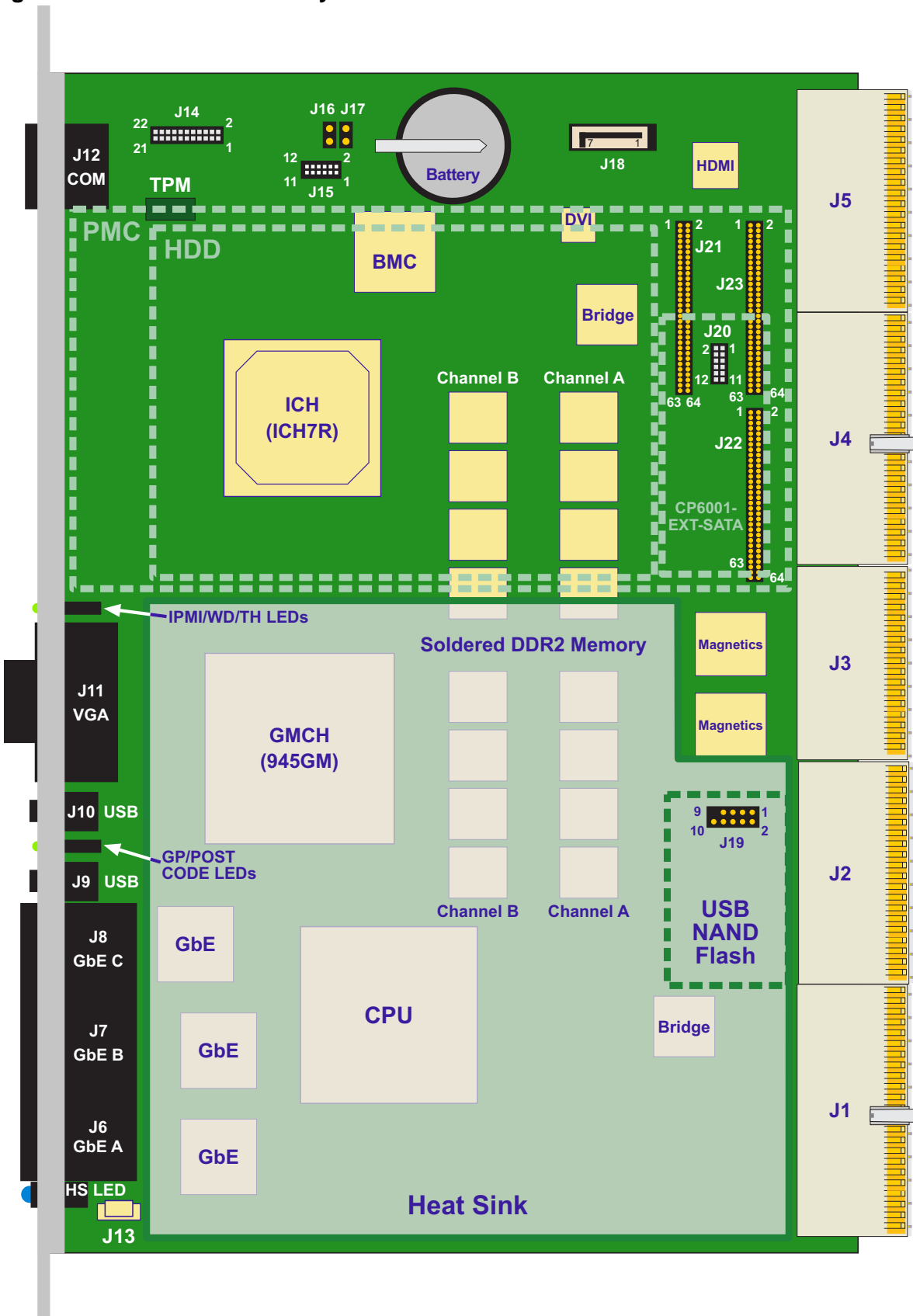

Figure 1-4: CP6001 Board Layout – Front View – R2 Version

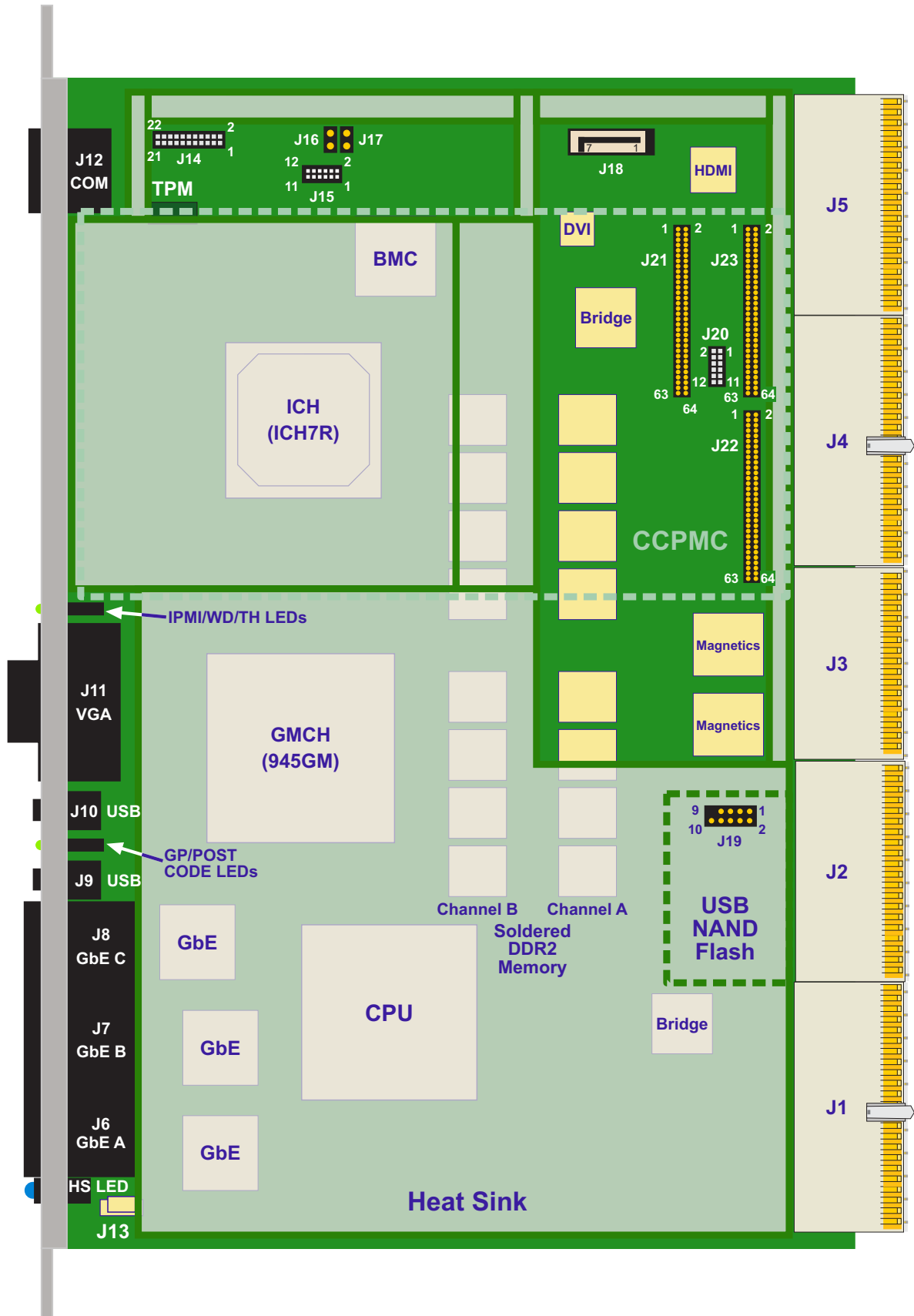
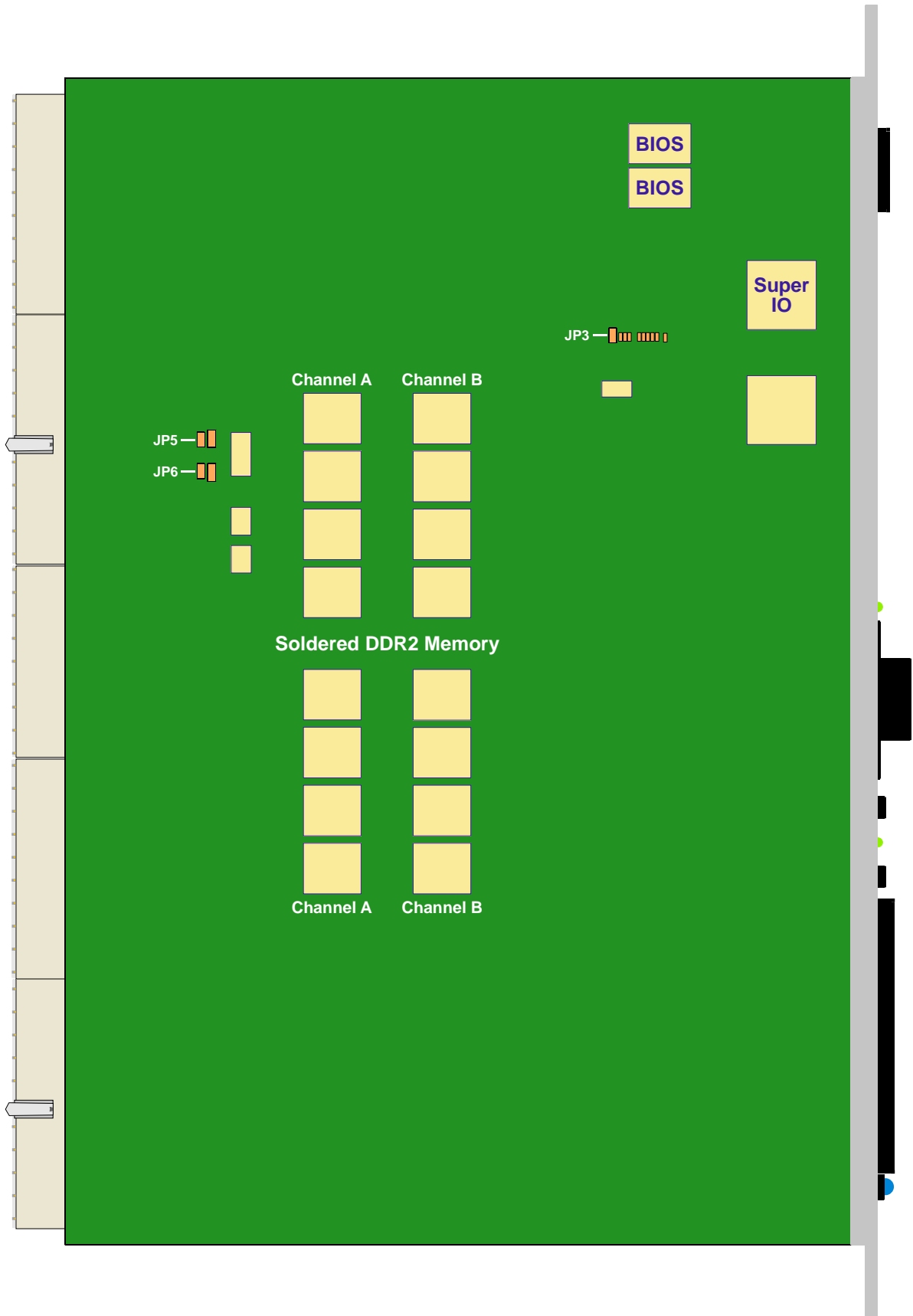



Figure 1-5: CP6001 Board Layout – Reverse View





1.5 Technical Specification

Table 1-1: CP6001 Main Specifications

CP6001		SPECIFICATIONS
Processor and Memory	CPU	<p>The CP6001 supports the following microprocessors:</p> <ul style="list-style-type: none"> Intel® Core™ Duo, U2500 (ULV), 1.2 GHz, 533 MHz FSB, 2 MB L2 cache Intel® Core™2 Duo, L7400 (LV), 1.5 GHz, 667 MHz FSB, 4 MB L2 cache <p>All microprocessors are provided in a 479 µFCBGA packaging.</p>
	Memory	<p>Main Memory:</p> <ul style="list-style-type: none"> Up to 4 GB dual-channel, DDR2 memory running at 533/667 MHz <p>Cache structure:</p> <ul style="list-style-type: none"> 64 kB L1 on-die full speed processor cache <ul style="list-style-type: none"> 32 kB for instruction cache 32 kB for data cache Up to 4 MB L2 on-die full speed processor cache <p>FLASH Memory:</p> <ul style="list-style-type: none"> Soldered CompactFlash (true IDE mode) Two 1 MB onboard FWHs for redundant BIOS <p>Memory Extension:</p> <ul style="list-style-type: none"> USB 2.0 NAND Flash <p>Serial EEPROM:</p> <ul style="list-style-type: none"> 24LC64 (64 kbit)
Chipset	Intel® 945GM Express GMCH	<p>Mobile Intel® 945GM Express Graphics Memory Controller Hub:</p> <ul style="list-style-type: none"> Support for a single Intel® Core™ Duo or Core™2 Duo microprocessor 64-bit AGTL/AGTL+ based System Bus interface up to 667 MHz System Memory interface with optimized support for dual-channel DDR2 SDRAM memory at 533/667 MHz without ECC Integrated 2D and 3D Graphics Engines Integrated 400 MHz RAMDAC
	Intel® ICH7R	<p>Intel® 82801GR I/O Controller Hub (ICH7R):</p> <ul style="list-style-type: none"> Power management logic support Enhanced DMA controller, interrupt controller, and timer functions Integrated IDE controller Ultra ATA/100/66/33 and PIO mode USB 2.0 host interface with up to seven USB ports SATA Host Controller with four ports, 3 Gbit/s transfer rate Five of the six x1 PCI Express ports are used on the CP6001: <ul style="list-style-type: none"> Three x1 PCI Express ports are used for Gigabit Ethernet Two x1 PCI Express ports are used for the PCI bridges System Management Bus (SMBus) compatible with most I²C™ devices Low Pin Count (LPC) interface Firmware Hub (FWH) interface support

Table 1-1: CP6001 Main Specifications (Continued)

CP6001	SPECIFICATIONS
CompactPCI	Compliant with CompactPCI Specification PICMG 2.0 R3.0: <ul style="list-style-type: none"> • System controller operation • 32-bit/66 MHz PCI/PCI-X master interface with support for up to 7 peripheral boards • 3.3V or 5V signaling levels (universal signaling support) Compliant with Packet Switching Specification PICMG 2.16 R1.0 When the CP6001 is operated in a peripheral slot, the CompactPCI bus is electrically isolated (passive mode).
Rear I/O	The following interfaces are routed to the rear I/O connector J3, J4 and J5: <ul style="list-style-type: none"> • COM1 and COM2 (RS-232 and RS-422 signaling); no buffer on the rear I/O module is necessary • 4 x USB 2.0 • CRT VGA, DVI, HDMI • PS/2 (Mouse/Keyboard) • 2 x Gigabit Ethernet (compliant with PICMG 2.16, R 1.0) • 4 x SATA • PMC/CCPMC rear I/O
Hot Swap Compatible	The board supports System Master hot swap functionality and application dependent hot swap functionality when used in a peripheral slot. When used as a System Master the board supports individual clocks for each slot and ENUM signal handling is in compliance with the PICMG 2.1 Hot Swap Specification.
VGA	Built-in Intel 3D Graphics accelerator for enhanced graphics performance. <ul style="list-style-type: none"> • Supports resolutions of up to 2048 x 1536 at a 75 Hz refresh rate • Hardware motion compensation for software MPEG2 decoding • Dynamic Video Memory Technology (DVMT3.0)
Gigabit Ethernet	Up to three 10 Base-T/100 Base-TX/1000 Base-T Gigabit Ethernet interfaces based on three Intel® 82573L Ethernet PCI Express bus controllers. <ul style="list-style-type: none"> • Two RJ-45 connectors on front panel switchable to rear I/O (PICMG 2.16) • One RJ-45 connector on the front panel • Automatic mode recognition (Auto-Negotiation) • Automatic cabling configuration recognition (Auto MDI-X) Cabling requirement: Category 5, UTP, four-pair cabling
USB	Seven USB 2.0 ports supporting UHCI and EHCI: <ul style="list-style-type: none"> • Two type A connectors on the front panel • Four ports on the rear I/O interface • One onboard connector for the USB 2.0 NAND Flash module

Table 1-1: CP6001 Main Specifications (Continued)

CP6001		SPECIFICATIONS
Interfaces	Serial	Two 16C550-compatible UARTs on the rear I/O interface, one for RS-232 and one for RS-422 signaling. The UART for RS-232 signaling is also routed to the front panel.
	PMC / CCPMC	CMC/PMC P1386/Draft 2.4a and CCPMC VITA 20-2001 (R2005) compliant mezzanine interface: <ul style="list-style-type: none"> • PMC module support only on the R1 version if no HDD is installed • CCPMC module support on the R2 version • Jn1, Jn2 and Jn4 PCI mezzanine connectors for standard PMC modules • 32-bit/66 MHz PCI/PCI-X interface • Rear I/O supported through the CompactPCI connector J4 • Supported voltages: 3.3 V, 5 V, +12 V, and -12 V • Supports 3.3 V signaling voltage (VI/O)
	Keyboard and Mouse	Keyboard and mouse are supported <ul style="list-style-type: none"> • USB Support • PS/2 (keyboard and mouse) on rear I/O
	Mass Storage	EIDE ATA: <ul style="list-style-type: none"> • One onboard ATA interface for the soldered CompactFlash SATA: Integrated Serial ATA Host Controllers <ul style="list-style-type: none"> • Provide independent DMA operation on 4 channels: <ul style="list-style-type: none"> • Two onboard SATA interfaces switchable to rear I/O via BIOS • Two SATA interfaces only on rear I/O • Data transfer rates up to 300 MBs Onboard 2.5" hard disk: <ul style="list-style-type: none"> • Onboard 2.5" hard disk is supported via a 22-pin Serial ATA interface on the CP6001-EXT-SATA module
	I/O Extension Interface	I/O extension interface: <ul style="list-style-type: none"> • LPC devices
Sockets	Front Panel Connectors	<ul style="list-style-type: none"> • VGA: 15-pin, D-Sub connector • USB: two type A connectors • Ethernet: three RJ-45 connectors • COM: 8-pin, RJ-45 connector • PMC front panel (only on R1)
	Onboard Connectors	<ul style="list-style-type: none"> • USB 2.0 NAND Flash connector, J19 • I/O extension connector, J14 • PMC connectors J21 - J23 (Jn1, Jn2 and Jn4) • Two SATA connectors: <ul style="list-style-type: none"> • One 7-pin, standard SATA connector with locking mechanism, J18 • One 12-pin, SATA extension connector, J20 • CompactPCI Connector J1 to J3 (J4 - J5 optional) • J15 for factory use only

Table 1-1: CP6001 Main Specifications (Continued)



CP6001		SPECIFICATIONS
HW Monitoring	LEDs	<p>System Status LEDs:</p> <ul style="list-style-type: none"> • I0/I1 (red/green): Indicate the software status of the IPMI controller • WD (red/green): Watchdog Status • TH (red/green/amber): Overtemperature Status • HS (blue): Hot Swap Control <p>General Purpose LEDs:</p> <ul style="list-style-type: none"> • LED 0..3 (red/green/amber): General Purpose/POST code <p>Gigabit Ethernet Status:</p> <ul style="list-style-type: none"> • ACT (green): Ethernet Link/Activity • SPEED (green/orange): Ethernet Speed • SPEED ON (orange): 1000 Mbit • SPEED ON (green): 100 Mbit • SPEED OFF: 10 Mbit
	Watchdog	Software configurable Watchdog generates IRQ or hardware reset.
	Thermal-Related Functions	<p>Thermal monitor and control:</p> <ul style="list-style-type: none"> • Onboard temperature sensors: <ul style="list-style-type: none"> • Temp1 sensor • Temp2 sensor • Temperature sensor integrated in the Super I/O • Processor thermal monitoring and regulation: <ul style="list-style-type: none"> • Intel® Thermal Monitor (TM1 and TM2) • Intel® SpeedStep® • Catastrophic cooling failure sensor • Two Digital Thermal Sensors (one per core) • Thermal Diode Sensor • Convection cooling
	System Monitor	<p>In SCH3112 integrated hardware monitor for supervision of:</p> <ul style="list-style-type: none"> • Two fan speed inputs • Board temperature
IPMI	<p>Baseboard Management Controller (BMC) that supports two keyboard controller-style interfaces (KCS) compliant with:</p> <ul style="list-style-type: none"> • IPMI specification v1.5 • PICMG 2.9 specification <p>IPMI supports two IPMB busses via the J1 and J2 connectors.</p>	



Table 1-1: CP6001 Main Specifications (Continued)

CP6001		SPECIFICATIONS
Software	Software BIOS	AMI BIOS with 1 MB Flash memory with the following features: <ul style="list-style-type: none"> • User BIOS defaults (Setup Default Override - SDO) • ACPI support • FWH write protection (BIOS Flash) • Manufacturing data: <ul style="list-style-type: none"> • Serial number • Material number • Chipset revision • CPU microcode • QuickBoot • QuietBoot • LAN boot capability for diskless systems (standard PXE) • Boot from USB floppy disk drive • USB keyboard emulation during BIOS boot • Plug and Play capability • BIOS parameters are saved in the EEPROM • Hardware Health Monitoring
	Operating Systems	Operating systems supported: <ul style="list-style-type: none"> • Microsoft® Windows® XP • Microsoft® Windows® XP Embedded • Linux • VxWorks Please contact Kontron for further information concerning the operation of the CP6001 with other operating systems.

Table 1-1: CP6001 Main Specifications (Continued)

CP6001		SPECIFICATIONS
General	Mechanical	6U, 4HP, CompactPCI compliant form factor
	Power Consumption	See Chapter 5 for details
	Temperature Ranges	Operational: 0°C to +60°C Standard -40°C to +85°C E2, optional (TPM: -25°C to +70°C) Storage: -55°C to +85°C Without battery or any additional components  <p>Note ... When a battery is installed, refer to the operational specifications of the battery as this determines the board's storage temperature (See "Battery" below).</p>  <p>Note ... When additional components are installed, refer to their operational specifications as this will influence the board's operational and storage temperature.</p>
	Climatic Humidity	93% RH at 40°C, non-condensing (acc. to IEC 60068-2-78)
	Dimensions	233.35 mm x 160 mm
	Board Weight	R1: 630 g (4HP with front panel and heat sink and without mezzanine boards) R2: 650 g (4HP with front panel, heat sink and stiffeners and without mezzanine boards)
	Battery	The CP6001 R1 version provides a 3.0V lithium battery for RTC with battery socket. Recommended type: CR2025 Temperature ranges: Operational: -20°C to +70°C typical (refer to the battery manufacturer's specifications for exact range) Storage: -55°C to +70°C typical (no discharge)

1.6 Kontron Software Support

Kontron is one of the few CompactPCI and VME manufacturers providing inhouse support for most of the industry-proven real-time operating systems that are currently available. Due to its close relationship with the software manufacturers, *Kontron* is able to produce and support BSPs and drivers for the latest operating system revisions thereby taking advantage of the changes in technology.

1.7 Standards

The board complies with the requirements of the following standards:

Table 1-2: Standards for the CP6001 R1 and R2 versions

TYPE	ASPECT	STANDARD	REMARKS
CE	Emission	EN55022 EN61000-6-3	--
	Immission	EN55024 EN61000-6-2	--
	Electrical Safety	EN60950-1	--
Mechanical	Mechanical Dimensions	IEEE 1101.10	--
Environmental	Climatic Humidity	IEC60068-2-78	See note below
	Generic Environmental	ANSI/VITA 47	--
	WEEE	Directive 2002/96/EC	Waste electrical and electronic equipment
	RoHS	Directive 2002/95/EC	Restriction of the use of certain hazardous substances in electrical and electronic equipment
	Vibration (Sinusoidal)	IEC61131-2 IEC60068-2-6	Test parameters: <ul style="list-style-type: none"> • 5-150 (Hz) frequency range • 1 (g) acceleration • 1 (oct/min) sweep rate • 10 cycles/axis • 3 axes
	Single Shock	IEC61131-2 IEC60068-2-27	Test parameters: <ul style="list-style-type: none"> • 15 (g) acceleration • 11 (ms) pulse duration • 3 shocks per direction • 6 directions • 5 (s) recovery time



Note ...

Kontron performs comprehensive environmental testing of its products in accordance with applicable standards.

Customers desiring to perform further environmental testing of Kontron products must contact Kontron for assistance prior to performing any such testing. This is necessary, as it is possible that environmental testing can be destructive when not performed in accordance with the applicable specifications.

In particular, for example, boards **without conformal coating** must not be exposed to a change of temperature exceeding 1K/minute, averaged over a period of not more than five minutes. Otherwise, condensation may cause irreversible damage, especially when the board is powered up again.

Kontron does not accept any responsibility for damage to products resulting from destructive environmental testing.

The test parameters indicated in the table below are valid only if the CP6001 R2 version is operated in a chassis with the capability to fixate the board's upper and lower card edges. The front panel I/O performance may be reduced if the board is operated in accordance with the ANSI/VITA 47 Class V2 specification. For full performance in accordance with the ANSI/VITA 47 Class V2 specification, use the CompactPCI and rear I/O ports.

Table 1-3: Additional Standards for the CP6001 R2 Version

TYPE	ASPECT	STANDARD	REMARKS
Environmental	Random Vibration (Broadband)	ANSI/VITA 47 Class V2 MIL-STD-810E Method 514 Procedure I	Test parameters: <ul style="list-style-type: none"> • 5-100 (Hz) frequency range; +3 (dB) slope • 100-1000 (Hz) frequency range; 0.04 (g²/Hz) PSD • 1000-2000 (Hz) frequency range; -6 (dB) slope • 60 (min) test duration / axis • 3 axes
	Single Shock	ANSI/VITA 47 Class V2 MIL-STD-810E Method 516 Procedure I	Test parameters: <ul style="list-style-type: none"> • 20 (g) acceleration • 11 (ms) pulse duration (half-sine) • 3 shocks per direction • 6 directions • 5 (s) recovery time

1.8 Related Publications

The following publications contain information relating to this product.

Table 1-4: Related Publications

PRODUCT	PUBLICATION
CompactPCI Systems and Boards	CompactPCI Specification 2.0, Rev. 3.0 CompactPCI Packet Switching Backplane Specification PICMG 2.16 Rev. 1.0 CompactPCI System Management Specification PICMG 2.9 Rev. 1.0 CompactPCI Hot Swap Specification PICMG 2.1 Rev. 2.0
	IPMI - Intelligent Platform Management Interface Specification v1.5
	<i>Kontron</i> CompactPCI Backplane Manual, ID 24229
CompactFlash Cards	CF+ and CompactFlash Specification Revision 2.1
PMC Module	IEEE 1386-2001, IEEE Standard for a Common Mezzanine Card (CMC) Family IEEE 1386.1-2001, IEEE Standard Physical and Environmental Layers for PCI Mezzanine Cards (PMC)
CCPMC Modules	VITA 20-2001 (R2005)
All Kontron products	Product Safety and Implementation Guide, ID 1021-9142