

# **CP6001-R3**

**Ruggedized  
6U CompactPCI Processor Board Based  
on the Intel® Core™ Duo Processor and  
the Intel® Core™2 Duo Processor with the  
Intel® 945GM Express Chipset**

Doc. ID: 1027-2047, Rev. 1.0  
December 2, 2008

## **User Guide**



## Revision History

<b>Publication Title:</b>		<b>CP6001-R3: Ruggedized 6U CompactPCI Processor Board Based on the Intel® Core™ Duo Processor and the Intel® Core™ 2 Duo Processor with the Intel® 945GM Express Chipset</b>
<b>Doc. ID:</b>		<b>1027-2047</b>
<b>Rev.</b>	<b>Brief Description of Changes</b>	<b>Date of Issue</b>
1.0	Initial issue	2-Dec-2008

## Imprint

Kontron Modular Computers GmbH may be contacted via the following:

### MAILING ADDRESS

Kontron Modular Computers GmbH  
Sudetenstraße 7  
D - 87600 Kaufbeuren Germany

### TELEPHONE AND E-MAIL

+49 (0) 800-SALESKONTRON  
sales@kontron.com

For further information about other Kontron products, please visit our Internet web site: [www.kontron.com](http://www.kontron.com).

## Disclaimer

Copyright © 2008 Kontron AG. All rights reserved. All data is for information purposes only and not guaranteed for legal purposes. Information has been carefully checked and is believed to be accurate; however, no responsibility is assumed for inaccuracies. Kontron and the Kontron logo and all other trademarks or registered trademarks are the property of their respective owners and are recognized. Specifications are subject to change without notice.



## Table of Contents

<i>Revision History</i> .....	<i>ii</i>
<i>Imprint</i> .....	<i>ii</i>
<i>Disclaimer</i> .....	<i>ii</i>
<i>Table of Contents</i> .....	<i>iii</i>
<i>List of Tables</i> .....	<i>vii</i>
<i>List of Figures</i> .....	<i>ix</i>
<i>Proprietary Note</i> .....	<i>xi</i>
<i>Trademarks</i> .....	<i>xi</i>
<i>Environmental Protection Statement</i> .....	<i>xi</i>
<i>Explanation of Symbols</i> .....	<i>xii</i>
<i>For Your Safety</i> .....	<i>xiii</i>
<i>High Voltage Safety Instructions</i> .....	<i>xiii</i>
<i>Special Handling and Unpacking Instructions</i> .....	<i>xiii</i>
<i>General Instructions on Usage</i> .....	<i>xiv</i>
<i>Two Year Warranty</i> .....	<i>xv</i>
<b>1. Introduction</b> .....	<b>1 - 3</b>
1.1 <i>Board Overview</i> .....	1 - 3
1.2 <i>Board-Specific Information</i> .....	1 - 4
1.3 <i>System Expansion Capabilities</i> .....	1 - 5
1.3.1 <i>CCPMC Module</i> .....	1 - 5
1.4 <i>Board Diagrams</i> .....	1 - 5
1.4.1 <i>Functional Block Diagram</i> .....	1 - 5
1.4.2 <i>Board Layout</i> .....	1 - 6
1.5 <i>Technical Specification</i> .....	1 - 8
1.6 <i>Kontron Software Support</i> .....	1 - 12
1.7 <i>Standards</i> .....	1 - 12
1.8 <i>Related Publications</i> .....	1 - 13
<b>2. Functional Description</b> .....	<b>2 - 3</b>
2.1 <i>CPU, Memory and Chipset</i> .....	2 - 3
2.1.1 <i>CPU</i> .....	2 - 3
2.1.2 <i>Memory</i> .....	2 - 5



- 2.1.3 *Intel® 945GM Express Chipset Overview* ..... 2 - 5
- 2.1.4 *Mobile Intel® 945GM Express Chipset GMCH* ..... 2 - 5
- 2.1.5 *I/O Controller Hub (ICH7R)* ..... 2 - 6
- 2.2 *Peripherals* ..... 2 - 6
  - 2.2.1 *Timer* ..... 2 - 6
  - 2.2.2 *Watchdog Timer* ..... 2 - 6
  - 2.2.3 *Reset* ..... 2 - 7
  - 2.2.4 *SMBus Devices* ..... 2 - 7
  - 2.2.5 *Thermal Management/System Monitoring* ..... 2 - 7
  - 2.2.6 *Serial EEPROM* ..... 2 - 8
  - 2.2.7 *FLASH Memory* ..... 2 - 8
  - 2.2.8 *Trusted Platform Module (TPM) 1.2* ..... 2 - 9
- 2.3 *Board Interfaces* ..... 2 - 9
  - 2.3.1 *USB Interfaces* ..... 2 - 9
  - 2.3.2 *Graphics Controller* ..... 2 - 10
  - 2.3.3 *CCPMC Interface* ..... 2 - 11
  - 2.3.4 *COM Ports* ..... 2 - 14
  - 2.3.5 *Gigabit Ethernet* ..... 2 - 14
  - 2.3.6 *Serial ATA Interface* ..... 2 - 14
  - 2.3.7 *CompactPCI Interface* ..... 2 - 14
  - 2.3.8 *CompactPCI Bus Connector* ..... 2 - 16
- 2.4 *Intelligent Platform Management Interface* ..... 2 - 25
  - 2.4.1 *Technical Background of IPMI* ..... 2 - 25
  - 2.4.2 *IPMI Glossary* ..... 2 - 26
  - 2.4.3 *IPMI Implementation on the CP6001-R3* ..... 2 - 27
  - 2.4.4 *Sensors Implemented on the CP6001-R3* ..... 2 - 28
  - 2.4.5 *Data Repositories* ..... 2 - 29

**3. *Installation* ..... 3 - 3**

- 3.1 *Safety Requirements* ..... 3 - 3
- 3.2 *Initial Installation Procedures* ..... 3 - 4
- 3.3 *Standard Removal Procedures* ..... 3 - 6
- 3.4 *Hot Swap Procedures* ..... 3 - 6



3.4.1	System Master Hot Swap .....	3 - 7
3.4.2	CP6001-R3 Hot Swap Procedure .....	3 - 7
3.5	Installation of CP6001-R3 Peripheral Devices .....	3 - 9
3.5.1	USB Device Installation .....	3 - 9
3.5.2	Rear I/O Device Installation .....	3 - 9
3.6	CCPMC Module Installation .....	3 - 9
3.7	Software Installation .....	3 - 9
<b>4.</b>	<b>Configuration .....</b>	<b>4 - 3</b>
4.1	Jumper Description .....	4 - 3
4.1.1	Clearing BIOS CMOS Setup .....	4 - 3
4.1.2	COM2 Termination Jumper Settings .....	4 - 3
4.1.3	Shorting Chassis GND (Shield) to Logic GND .....	4 - 4
4.2	Write Protection for Non-Volatile Memory Devices .....	4 - 4
4.3	I/O Address Map .....	4 - 5
4.4	CP6001-R3-Specific Registers .....	4 - 6
4.4.1	Status Register 0 .....	4 - 6
4.4.2	Status Register 1 .....	4 - 7
4.4.3	Control Register 0 .....	4 - 8
4.4.4	Control Register 1 .....	4 - 8
4.4.5	Device Protection Register .....	4 - 9
4.4.6	Reset Status Register .....	4 - 10
4.4.7	Board Interrupt Configuration Register .....	4 - 11
4.4.8	Board ID Register .....	4 - 11
4.4.9	Board and PLD Revision Register .....	4 - 12
4.4.10	Geographic Addressing Register .....	4 - 12
4.4.11	Delay Timer Register .....	4 - 13
4.4.12	Watchdog Timer Control Register .....	4 - 14
4.4.13	LED Configuration Register .....	4 - 16
4.4.14	LED Control Register .....	4 - 16
4.4.15	General Purpose Data Register .....	4 - 17
4.4.16	General Purpose Control Register .....	4 - 17



4.5	<i>BMC-Specific Registers</i>	4 - 18
4.5.1	<i>IPMI Boot Configuration Register</i>	4 - 18
4.5.2	<i>IPMI Controller Configuration Register</i>	4 - 19
4.5.3	<i>IPMI Controller Status Register</i>	4 - 20
4.5.4	<i>IPMI Reset Status Register</i>	4 - 21
4.5.5	<i>IPMI Keyboard Control Style Interface</i>	4 - 22
<b>5.</b>	<b><i>Power Considerations</i></b>	<b>5 - 3</b>
5.1	<i>System Power</i>	5 - 3
5.1.1	<i>CP6001-R3 Baseboard</i>	5 - 3
5.1.2	<i>Backplane</i>	5 - 4
5.1.3	<i>Power Supply Units</i>	5 - 4
5.2	<i>Power Consumption</i>	5 - 6
5.2.1	<i>Power Consumption of the CP6001-R3 Accessories</i>	5 - 8
5.2.2	<i>Power Consumption of the Gigabit Ethernet Controller</i>	5 - 8
5.3	<i>Start-Up Currents of the CP6001-R3</i>	5 - 9
5.4	<i>Power Available for CCPMC Devices</i>	5 - 9
<b>6.</b>	<b><i>Thermal Considerations</i></b>	<b>6 - 3</b>
6.1	<i>Board Internal Thermal Monitoring</i>	6 - 3
6.2	<i>Processor Thermal Monitoring and Regulation</i>	6 - 4
6.2.1	<i>Digital Thermal Sensor (DTS)</i>	6 - 4
6.2.2	<i>Thermal Diode Sensor</i>	6 - 4
6.2.3	<i>Thermal Monitor 1 (TM1)</i>	6 - 4
6.2.4	<i>Thermal Monitor 2 (TM2)</i>	6 - 5
6.2.5	<i>TM1 and TM2 Operation</i>	6 - 5
6.2.6	<i>Catastrophic Cooling Failure Sensor</i>	6 - 5
6.3	<i>Thermal Characteristics for the CP6001-R3</i>	6 - 5
6.4	<i>Peripherals</i>	6 - 7



## List of Tables

1-1	<i>CP6001-R3 Main Specifications</i> .....	1 - 8
1-2	<i>Standards for the R3 Version</i> .....	1 - 12
1-3	<i>Related Publications</i> .....	1 - 13
2-1	<i>Processors Supported on the CP6001-R3</i> .....	2 - 4
2-2	<i>Maximum Power Dissipation of the Processors (CPU only)</i> .....	2 - 4
2-3	<i>CPU Frequency in the Various SpeedStep® Modes</i> .....	2 - 4
2-4	<i>Supported Memory Configurations</i> .....	2 - 5
2-5	<i>SMBus Device Addresses</i> .....	2 - 7
2-6	<i>EEPROM Address Map</i> .....	2 - 8
2-7	<i>Onboard PCI Configuration</i> .....	2 - 11
2-8	<i>CCPMC Connectors J7 and J9 Pinouts</i> .....	2 - 12
2-9	<i>CCPMC Connector J8 Pinout</i> .....	2 - 13
2-10	<i>CompactPCI Bus Connector J1 System Slot Pinout</i> .....	2 - 17
2-11	<i>CompactPCI Bus Connector J1 Peripheral Slot Pinout</i> .....	2 - 18
2-12	<i>64-bit CompactPCI Bus Connector J2 System Slot Pinout</i> .....	2 - 19
2-13	<i>64-bit CompactPCI Bus Connector J2 Peripheral Slot Pinout</i> .....	2 - 20
2-14	<i>CompactPCI Rear I/O Connector J3 Pinout</i> .....	2 - 21
2-15	<i>CompactPCI Rear I/O Connector J3 Signals</i> .....	2 - 22
2-16	<i>CompactPCI Rear I/O Connector J4 Pinout</i> .....	2 - 23
2-17	<i>CompactPCI Rear I/O Connector J5 Pinout</i> .....	2 - 24
2-18	<i>CompactPCI Rear I/O Connector J5 Signals</i> .....	2 - 25
2-19	<i>Processor, Chipset and General Board Supervision</i> .....	2 - 28
2-20	<i>Various BMC/SMC Sensors</i> .....	2 - 28
2-21	<i>CompactPCI Sensors</i> .....	2 - 28
2-22	<i>Onboard Power Supply Supervision</i> .....	2 - 29
2-23	<i>Onboard Voltage Sensors</i> .....	2 - 29
2-24	<i>Temperature Sensors</i> .....	2 - 29
2-25	<i>Fan Sense Sensors</i> .....	2 - 29
4-1	<i>Clearing BIOS CMOS Setup</i> .....	4 - 3
4-2	<i>Jumper Setting for RS-422 TXD Termination (COM2)</i> .....	4 - 3
4-3	<i>Jumper Setting for RS-422 RXD Termination (COM2)</i> .....	4 - 3
4-4	<i>Write Protection for Non-Volatile Memory Devices</i> .....	4 - 4



4-5	<i>I/O Address Map</i>	4 - 5
4-6	<i>Status Register 0</i>	4 - 6
4-7	<i>Status Register 1</i>	4 - 7
4-8	<i>Control Register 0</i>	4 - 8
4-9	<i>Control Register 1</i>	4 - 8
4-10	<i>Device Protection Register</i>	4 - 9
4-11	<i>Reset Status Register</i>	4 - 10
4-12	<i>Board Interrupt Configuration Register</i>	4 - 11
4-13	<i>Board ID Register</i>	4 - 11
4-14	<i>Board and PLD Revision Register</i>	4 - 12
4-15	<i>Geographic Addressing Register</i>	4 - 12
4-16	<i>Delay Timer Register</i>	4 - 13
4-17	<i>Watchdog Timer Control Register</i>	4 - 15
4-18	<i>LED Configuration Register</i>	4 - 16
4-19	<i>LED Control Register</i>	4 - 16
4-20	<i>General Purpose Data Register</i>	4 - 17
4-21	<i>General Purpose Control Register</i>	4 - 17
4-22	<i>IPMI Boot Configuration Register</i>	4 - 18
4-23	<i>IPMI Controller Configuration Register</i>	4 - 19
4-24	<i>COM Port Routing for the Firmware Update and Debugging Purposes</i>	4 - 19
4-25	<i>IPMI Controller Status Register</i>	4 - 20
4-26	<i>IPMI Reset Status Register</i>	4 - 21
5-1	<i>Maximum Input Power Voltage Limits</i>	5 - 3
5-2	<i>DC Operational Input Voltage Ranges</i>	5 - 3
5-3	<i>Input Voltage Characteristics</i>	5 - 5
5-4	<i>Power Consumption: CP6001-R3 with DOS</i>	5 - 7
5-5	<i>Power Consumption: CP6001-R3 with Linux/Win. XP in IDLE Mode</i>	5 - 7
5-6	<i>Power Consumption: CP6001-R3 at 75% TDP</i>	5 - 7
5-7	<i>Power Consumption: CP6001-R3 at 100% TDP</i>	5 - 8
5-8	<i>Power Consumption of CP6001-R3 Accessories</i>	5 - 8
5-9	<i>Intel® 82573L Gigabit Ethernet Controller Power Consumption</i>	5 - 8
5-10	<i>Start-Up Currents of the CP6001-R3</i>	5 - 9
5-11	<i>Maximum Output Power Limits</i>	5 - 9
6-1	<i>Maximum Reference Point Temperature at 100°C CPU Die Temperature</i>	6 - 6





## List of Figures

1-1	<i>CP6001-R3 Functional Block Diagram</i> .....	1 - 5
1-2	<i>CP6001-R3 Board Layout (Front View)</i> .....	1 - 6
1-3	<i>CP6001-R3 Board Layout (Reverse View)</i> .....	1 - 7
2-1	<i>CCPMC Connectors J7, J8 and J9</i> .....	2 - 11
2-2	<i>CPCI Connectors J1-J5</i> .....	2 - 16
6-1	<i>Temperature Sensor Placement (CP6001-R3 Top View)</i> .....	6 - 3
6-2	<i>Position of the Reference Point on the CP6001-R3</i> .....	6 - 6



This page has been intentionally left blank.





## Proprietary Note

This document contains information proprietary to Kontron. It may not be copied or transmitted by any means, disclosed to others, or stored in any retrieval system or media without the prior written consent of Kontron or one of its authorized agents.

The information contained in this document is, to the best of our knowledge, entirely correct. However, Kontron cannot accept liability for any inaccuracies or the consequences thereof, or for any liability arising from the use or application of any circuit, product, or example shown in this document.

Kontron reserves the right to change, modify, or improve this document or the product described herein, as seen fit by Kontron without further notice.

## Trademarks

Kontron, the *PEP* logo and, if occurring in this manual, “CXM” are trademarks owned by Kontron, Kaufbeuren (Germany). In addition, this document may include names, company logos and trademarks, which are registered trademarks and, therefore, proprietary to their respective owners.

## Environmental Protection Statement

This product has been manufactured to satisfy environmental protection requirements where possible. Many of the components used (structural parts, printed circuit boards, connectors, batteries, etc.) are capable of being recycled.

Final disposition of this product after its service life must be accomplished in accordance with applicable country, state, or local laws or regulations.



## Explanation of Symbols



### ***Caution, Electric Shock!***

This symbol and title warn of hazards due to electrical shocks (> 60V) when touching products or parts of them. Failure to observe the precautions indicated and/or prescribed by the law may endanger your life/health and/or result in damage to your material.

Please refer also to the section “High Voltage Safety Instructions” on the following page.



### ***Warning, ESD Sensitive Device!***

This symbol and title inform that electronic boards and their components are sensitive to static electricity. Therefore, care must be taken during all handling operations and inspections of this product, in order to ensure product integrity at all times.

Please read also the section “Special Handling and Unpacking Instructions” on the following page.



### ***Warning!***

This symbol and title emphasize points which, if not fully understood and taken into consideration by the reader, may endanger your health and/or result in damage to your material.



### ***Note ...***

This symbol and title emphasize aspects the reader should read through carefully for his or her own advantage.



## For Your Safety

Your new Kontron product was developed and tested carefully to provide all features necessary to ensure its compliance with electrical safety requirements. It was also designed for a long fault-free life. However, the life expectancy of your product can be drastically reduced by improper treatment during unpacking and installation. Therefore, in the interest of your own safety and of the correct operation of your new Kontron product, you are requested to conform with the following guidelines.

### High Voltage Safety Instructions



#### **Warning!**

All operations on this device must be carried out by sufficiently skilled personnel only.



#### **Caution, Electric Shock!**

Before installing a not hot-swappable Kontron product into a system always ensure that your mains power is switched off. This applies also to the installation of piggybacks.

Serious electrical shock hazards can exist during all installation, repair and maintenance operations with this product. Therefore, always unplug the power cable and any other cables which provide external voltages before performing work.

### Special Handling and Unpacking Instructions



#### **ESD Sensitive Device!**

Electronic boards and their components are sensitive to static electricity. Therefore, care must be taken during all handling operations and inspections of this product, in order to ensure product integrity at all times.

Do not handle this product out of its protective enclosure while it is not used for operational purposes unless it is otherwise protected.

Whenever possible, unpack or pack this product only at EOS/ESD safe work stations. Where a safe work station is not guaranteed, it is important for the user to be electrically discharged before touching the product with his/her hands or tools. This is most easily done by touching a metal part of your system housing.

It is particularly important to observe standard anti-static precautions when changing piggybacks, ROM devices, jumper settings etc. If the product contains batteries for RTC or memory backup, ensure that the board is not placed on conductive surfaces, including anti-static plastics or sponges. They can cause short circuits and damage the batteries or conductive circuits on the board.



---

## General Instructions on Usage

In order to maintain Kontron's product warranty, this product must not be altered or modified in any way. Changes or modifications to the device, which are not explicitly approved by Kontron and described in this manual or received from Kontron's Technical Support as a special handling instruction, will void your warranty.

This device should only be installed in or connected to systems that fulfill all necessary technical and specific environmental requirements. This applies also to the operational temperature range of the specific board version, which must not be exceeded. If batteries are present, their temperature restrictions must be taken into account.

In performing all necessary installation and application operations, please follow only the instructions supplied by the present manual.

Keep all the original packaging material for future storage or warranty shipments. If it is necessary to store or ship the board, please re-pack it as nearly as possible in the manner in which it was delivered.

Special care is necessary when handling or unpacking the product. Please consult the special handling and unpacking instruction on the previous page of this manual.



## Two Year Warranty

Kontron grants the original purchaser of Kontron's products a **TWO YEAR LIMITED HARDWARE WARRANTY** as described in the following. However, no other warranties that may be granted or implied by anyone on behalf of Kontron are valid unless the consumer has the express written consent of Kontron.

Kontron warrants their own products, excluding software, to be free from manufacturing and material defects for a period of 24 consecutive months from the date of purchase. This warranty is not transferable nor extendible to cover any other users or long-term storage of the product. It does not cover products which have been modified, altered or repaired by any other party than Kontron or their authorized agents. Furthermore, any product which has been, or is suspected of being damaged as a result of negligence, improper use, incorrect handling, servicing or maintenance, or which has been damaged as a result of excessive current/voltage or temperature, or which has had its serial number(s), any other markings or parts thereof altered, defaced or removed will also be excluded from this warranty.

If the customer's eligibility for warranty has not been voided, in the event of any claim, he may return the product at the earliest possible convenience to the original place of purchase, together with a copy of the original document of purchase, a full description of the application the product is used on and a description of the defect. Pack the product in such a way as to ensure safe transportation (see our safety instructions).

Kontron provides for repair or replacement of any part, assembly or sub-assembly at their own discretion, or to refund the original cost of purchase, if appropriate. In the event of repair, refunding or replacement of any part, the ownership of the removed or replaced parts reverts to Kontron, and the remaining part of the original guarantee, or any new guarantee to cover the repaired or replaced items, will be transferred to cover the new or repaired items. Any extensions to the original guarantee are considered gestures of goodwill, and will be defined in the "Repair Report" issued by Kontron with the repaired or replaced item.

Kontron will not accept liability for any further claims resulting directly or indirectly from any warranty claim, other than the above specified repair, replacement or refunding. In particular, all claims for damage to any system or process in which the product was employed, or any loss incurred as a result of the product not functioning at any given time, are excluded. The extent of Kontron liability to the customer shall not exceed the original purchase price of the item for which the claim exists.

Kontron issues no warranty or representation, either explicit or implicit, with respect to its products' reliability, fitness, quality, marketability or ability to fulfil any particular application or purpose. As a result, the products are sold "as is," and the responsibility to ensure their suitability for any given task remains that of the purchaser. In no event will Kontron be liable for direct, indirect or consequential damages resulting from the use of our hardware or software products, or documentation, even if Kontron were advised of the possibility of such claims prior to the purchase of the product or during any period since the date of its purchase.

Please remember that no Kontron employee, dealer or agent is authorized to make any modification or addition to the above specified terms, either verbally or in any other form, written or electronically transmitted, without the company's consent.



This page has been intentionally left blank.





---

*Chapter*

**1**

---

# Introduction

---



This page has been intentionally left blank.





# 1. Introduction

## 1.1 Board Overview

The CP6001-R3 is a highly integrated, ruggedized, conduction cooled, 6U CompactPCI CPU board based on the Intel® Core™ Duo and the Intel® Core™2 Duo microprocessors combined with the high-performance Mobile Intel® 945GM Express Chipset.

The board is capable of supporting the Intel® Core™ Duo and the Intel® Core™2 Duo processor versions in 65 nm technology with 64 kB L1 and up to 4 MB L2 cache in a 479 µFCBGA package with frequencies of 1.2 GHz and 1.5 GHz providing 533/667 MHz front side bus speed. The CP6001-R3 utilizes the Mobile Intel® 945GM Express Chipset as Graphics Memory Controller Hub and the ICH7R as I/O Controller Hub.

The board includes up to 4 GB of soldered, dual-channel Double Data Rate 2 (DDR2) memory. The DDR2 memory operates at 533/667 MHz, depending on the CPU. A soldered CompactFlash solution is implemented via an IDE Flash controller combined with a NAND Flash memory.

The CP6001-R3 offers a complete set of data, communication and multimedia interfaces, such as one onboard Parallel ATA interface connected to the soldered CompactFlash. Rear I/O interfacing includes: two Gigabit Ethernet ports (Intel® 82573L) in accordance with the PICMG CompactPCI Packet Switching Backplane Specification 2.16, four Serial ATA interfaces, a high-resolution VGA interface (CRT), a DVI interface and an HDMI interface via dedicated SDVO transmitters, a single CCPMC interface with 32-bit/66 MHz with rear I/O interfacing only. In addition, four USB 2.0 ports are available and two COM ports, one RS-232 port and one RS-422 port all on rear I/O.

The CP6001-R3 provides safety and security via a Trusted Platform Module (TPM) 1.2, two redundant firmware hubs (FWH) and Intelligent Platform Management Interface (IPMI) support.

Designed to withstand even the toughest environmental conditions, the conduction cooled CP6001-R3 comes in the rugged level R3 and is available with extended temperature capabilities and also provides support for a CCPMC. It includes a heat spreader extending across the whole board which enables the heat to be conducted from the board to the chassis, and two wedge locks for mounting the board in the chassis.

Designed for stability and packaged in a rugged format, the board fits into all applications situated in industrial environments, including I/O intensive applications where only one slot is available for the CPU, making it a perfect core technology for long-life applications. Components with high temperature tolerance have been selected from embedded technology programs, and therefore offer long-term availability.

The board is offered with Microsoft® Windows® XP, Windows® XP Embedded, Linux, and VxWorks operating systems. Please contact Kontron for further information concerning the operation of the CP6001-R3 with other operating systems.



## 1.2 Board-Specific Information

The CP6001-R3 is a CompactPCI single-board computer based on the Intel® Core™ Duo and the Intel® Core™2 Duo processors and specifically designed for use in highly integrated platforms with solid mechanical interfacing (VITA 30.1) for a wide range of industrial environment applications.

Some of the CP6001-R3's outstanding features are:

- Designed to support for the following processors:
  - Intel® Core™ Duo, U2500 (ULV), 1.2 GHz, 533 MHz FSB, 2 MB L2 cache
  - Intel® Core™2 Duo, L7400 (LV), 1.5 GHz, 667 MHz FSB, 4 MB L2 cache
- 479-pin µFCBGA package
- 64 kB L1 and up to 4 MB L2 cache on-die, running at CPU speed
- Intel® 945GM and Intel® 82801GR (ICH7R) chipset
- Up to 4 GB DDR2-SDRAM memory running at 533/667 MHz
- Integrated 3D high-performance VGA controller
- Analog display support for up to 2048 x 1536 pixels at 75 Hz routed to rear I/O
- Two independent digital display interfaces: DVI and HDMI/DVI, both routed to rear I/O
- Support for up to two High Definition Audio codecs on rear I/O
- 32-bit / 66 MHz CompactPCI interface in accordance with the PICMG 2.0, Rev 3.0 spec.
- CCPMC interface with rear I/O support and PCI/PCI-X functionality, 32-bit/66 MHz
- Two Gigabit Ethernet interfaces utilizing an x1 lane PCI Express per GbE controller on rear I/O (PICMG 2.16)
- EIDE Ultra ATA interface for soldered CompactFlash
- Four Serial ATA interfaces on rear I/O
- Four USB 2.0 ports on rear I/O
- Two COM ports (RS-232 and RS-422) on rear I/O
- 4HP, 6U CompactPCI
- AMI BIOS
- Two 1 MB onboard FWHs for redundant BIOS
- Watchdog Timer
- Real-time clock
- Jumperless board configuration
- Passive heat spreader solution for conduction cooling
- Hot swap capability: as system controller or as peripheral device
- Supports PICMG Packet Switching Backplane Specification 2.16
- Rear I/O on J3 and J5; CCPMC (when installed) on J4
- IPMI compliant Baseboard Management Controller



### 1.3 System Expansion Capabilities

#### 1.3.1 CCPMC Module

The CP6001-R3 has one PCI/PCI-X, 32-bit/66 MHz, rear I/O capable, conduction cooled PMC (CCPMC) mezzanine interface. This interface supports a wide range of available CCPMC modules with PCI interfacing and provides an easy and flexible way to configure the CP6001-R3 for various application requirements.

For further information concerning the CCPMC interface, refer to Chapter 2.3.3, CCPMC Interface.

### 1.4 Board Diagrams

The following diagrams provide additional information concerning board functionality and component layout.

#### 1.4.1 Functional Block Diagram

Figure 1-1: CP6001-R3 Functional Block Diagram

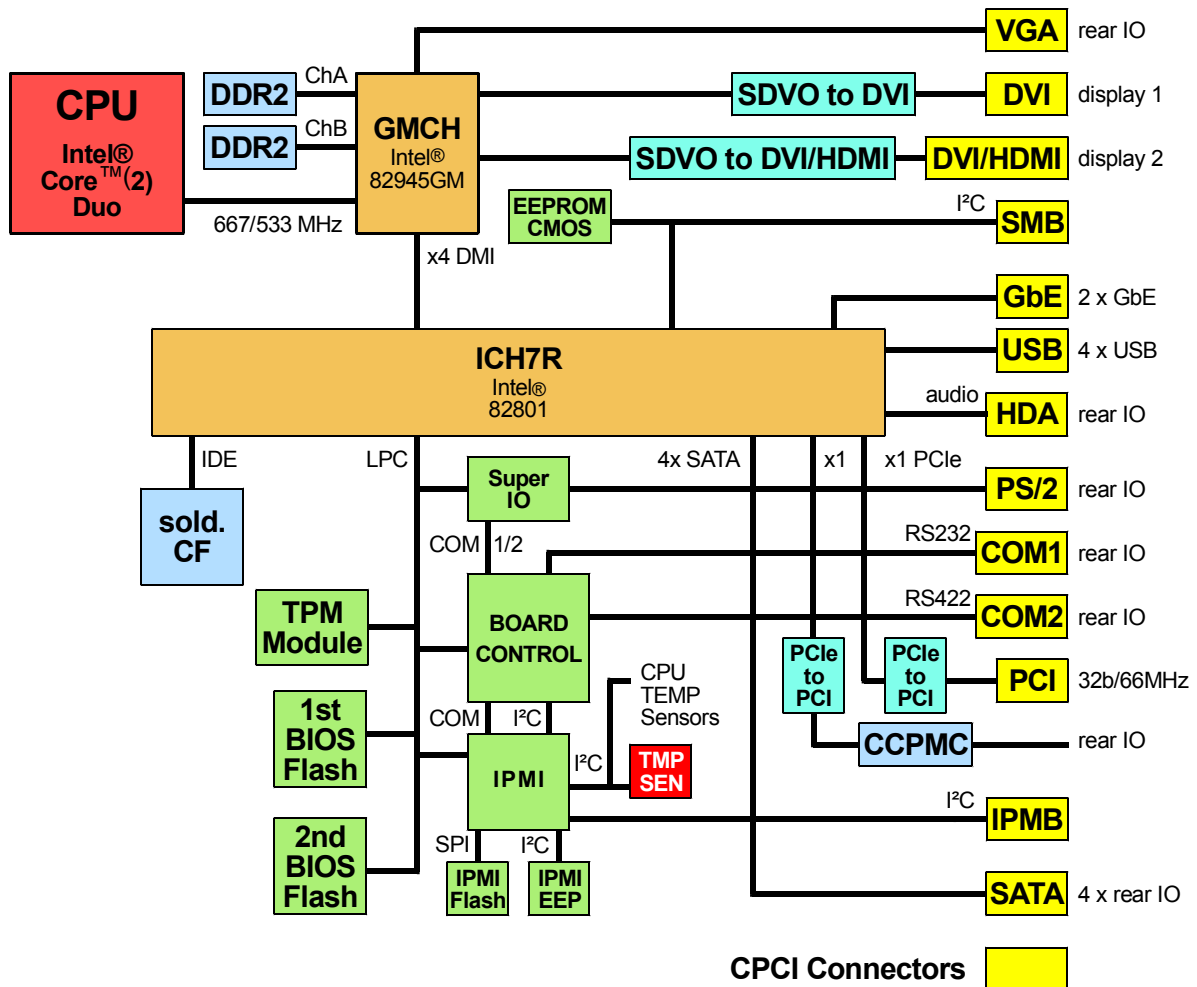

1.4.2 Board Layout

Figure 1-2: CP6001-R3 Board Layout (Front View)

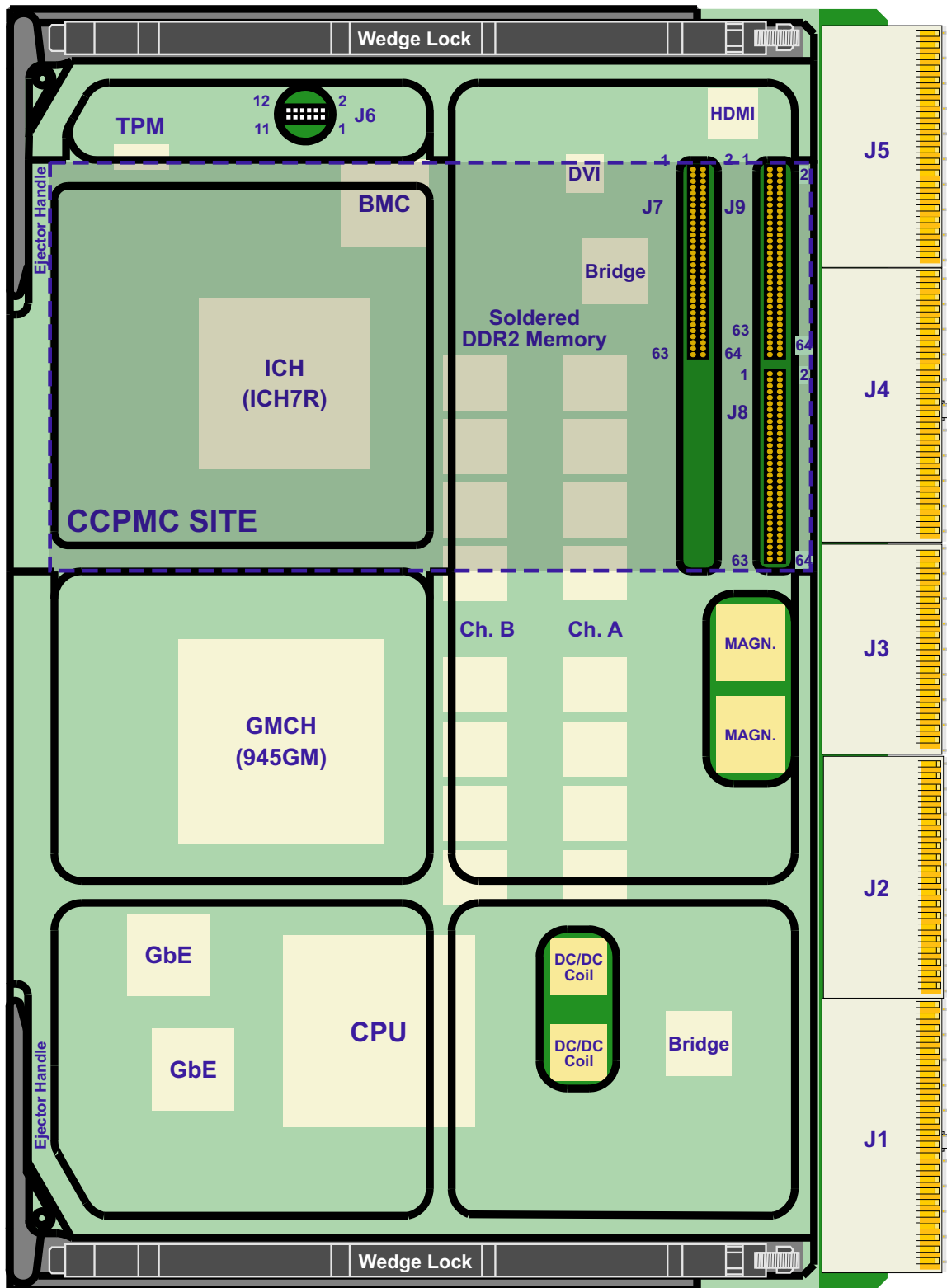
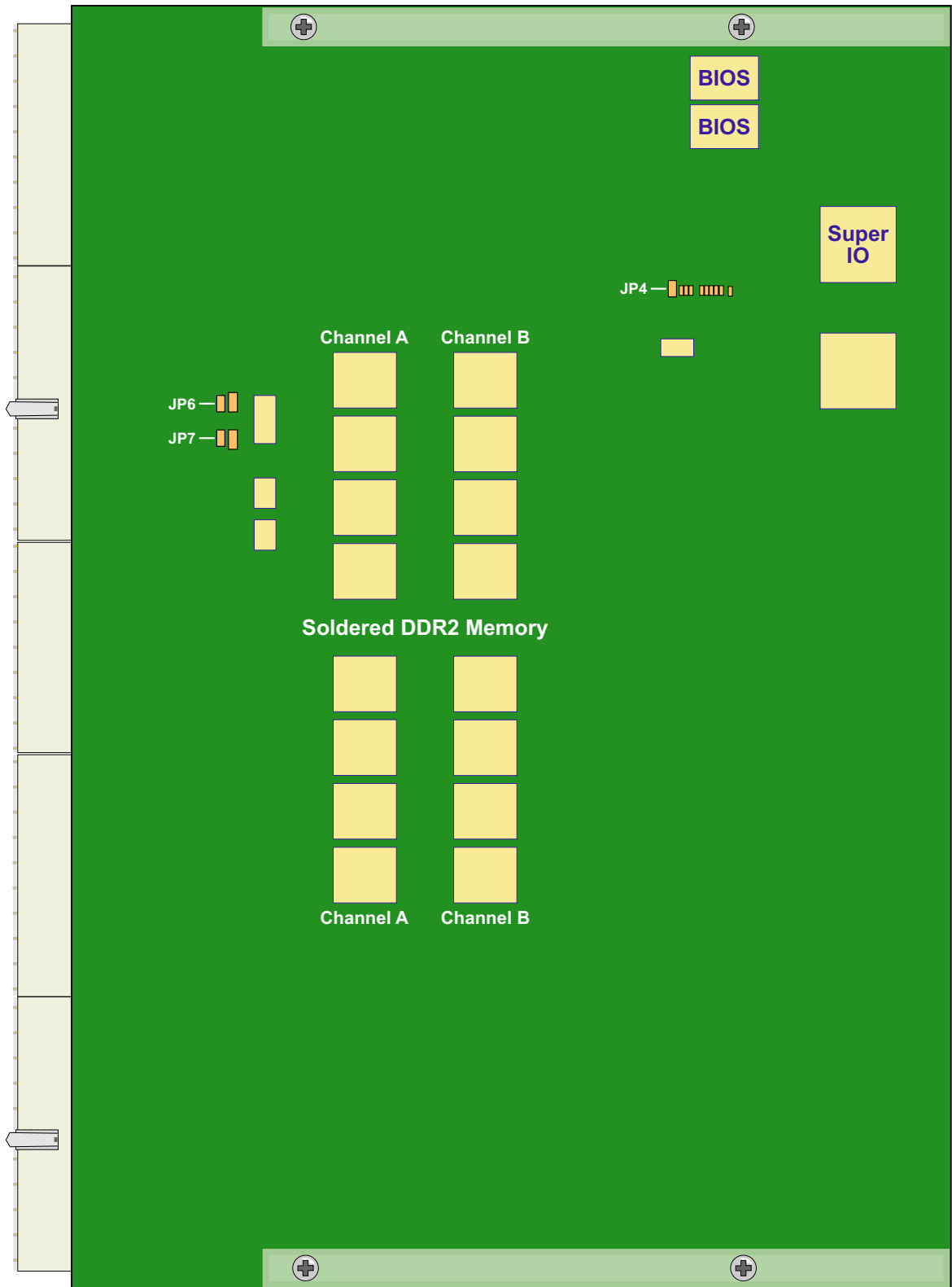

Figure 1-3: CP6001-R3 Board Layout (Reverse View)



## 1.5 Technical Specification

**Table 1-1: CP6001-R3 Main Specifications**

CP6001-R3		SPECIFICATIONS
Processor and Memory	CPU	<p>The CP6001-R3 supports the following microprocessors:</p> <ul style="list-style-type: none"> <li>Intel® Core™ Duo, U2500 (ULV), 1.2 GHz, 533 MHz FSB, 2 MB L2 cache</li> <li>Intel® Core™2 Duo, L7400 (LV), 1.5 GHz, 667 MHz FSB, 4 MB L2 cache</li> </ul> <p>All microprocessors are provided in a 479 μFCBGA packaging.</p>
	Memory	<p>Main memory:</p> <ul style="list-style-type: none"> <li>Up to 4 GB dual-channel, DDR2 memory running at 533/667 MHz</li> </ul> <p>Cache structure:</p> <ul style="list-style-type: none"> <li>64 kB L1 on-die full speed processor cache <ul style="list-style-type: none"> <li>32 kB for instruction cache</li> <li>32 kB for data cache</li> </ul> </li> <li>Up to 4 MB L2 on-die full speed processor cache</li> </ul> <p>Flash memory:</p> <ul style="list-style-type: none"> <li>Two 1 MB onboard FWHs for redundant BIOS</li> </ul> <p>Memory extension:</p> <ul style="list-style-type: none"> <li>Soldered CompactFlash (true IDE mode)</li> </ul> <p>Serial EEPROM:</p> <ul style="list-style-type: none"> <li>24LC64 (64 kbit)</li> </ul>
Chipset	Intel® 945GM Express GMCH	<p>Mobile Intel® 945GM Express Graphics Memory Controller Hub:</p> <ul style="list-style-type: none"> <li>Support for a single Intel® Core™ Duo or Core™2 Duo microprocessor</li> <li>64-bit AGTL/AGTL+ based System Bus interface up to 667 MHz</li> <li>System Memory interface with optimized support for dual-channel DDR2 SDRAM memory at 533/667 MHz without ECC</li> <li>Integrated 2D and 3D Graphics Engines</li> <li>Integrated 400 MHz RAMDAC</li> </ul>
	Intel® ICH7R	<p>Intel® 82801GR I/O Controller Hub (ICH7R):</p> <ul style="list-style-type: none"> <li>Power management logic support</li> <li>Enhanced DMA controller, interrupt controller, and timer functions</li> <li>Integrated IDE controller Ultra ATA/100/66/33 and PIO mode</li> <li>USB 2.0 host interface with up to four USB ports</li> <li>SATA Host Controller with four ports, 3 Gbit/s transfer rate</li> <li>Four of the six x1 PCI Express ports are used on the CP6001-R3: <ul style="list-style-type: none"> <li>Two x1 PCI Express ports are used for Gigabit Ethernet</li> <li>Two x1 PCI Express ports are used for the PCI bridges</li> </ul> </li> <li>System Management Bus (SMBus) compatible with most I<sup>2</sup>C™ devices</li> <li>Low Pin Count (LPC) interface</li> <li>Firmware Hub (FWH) interface support</li> </ul>

Table 1-1: CP6001-R3 Main Specifications (Continued)

CP6001-R3		SPECIFICATIONS
Interfaces	CompactPCI	<p>Compliant with CompactPCI Specification PICMG 2.0 R3.0:</p> <ul style="list-style-type: none"> <li>• System master operation</li> <li>• 32-bit/66 MHz PCI/PCI-X master interface</li> <li>• 3.3V or 5V signaling levels (universal signaling support)</li> </ul> <p>Compliant with Packet Switching Specification PICMG 2.16 R1.0</p> <p>When the CP6001-R3 is operated in a peripheral slot, the CompactPCI bus is electrically isolated (passive mode).</p>
	Rear I/O	<p>The following interfaces are routed to the rear I/O connector J3, J4 and J5:</p> <ul style="list-style-type: none"> <li>• COM1 and COM2 (RS-232 and RS-422 signaling); no buffer on the rear I/O module is necessary</li> <li>• 4 x USB 2.0</li> <li>• CRT VGA, DVI, HDMI</li> <li>• PS/2 (Mouse/Keyboard)</li> <li>• 2 x Gigabit Ethernet (compliant with PICMG 2.16, R 1.0)</li> <li>• 4 x SATA</li> <li>• CCPMC rear I/O</li> <li>• HDA digital output (requires external codec)</li> <li>• Fan control</li> <li>• Speaker</li> </ul>
	Hot Swap Compatible	<p>The CP6001-R3 supports System Master hot swap functionality and application dependent hot swap functionality when used in a peripheral slot.</p> <p>When used as a System Master the CP6001-R3 supports individual clocks for each slot and ENUM signal handling is in compliance with the PICMG 2.1 Hot Swap Specification.</p>
	VGA	<p>Built-in Intel 3D Graphics accelerator for enhanced graphics performance.</p> <ul style="list-style-type: none"> <li>• Supports resolutions of up to 2048 x 1536 at a 75 Hz refresh rate</li> <li>• Hardware motion compensation for software MPEG2 decoding</li> <li>• Dynamic Video Memory Technology (DVMT3.0)</li> </ul>
	Gigabit Ethernet	<p>Two 10 Base-T/100 Base-TX/1000 Base-T Gigabit Ethernet interfaces based on two Intel® 82573L Ethernet PCI Express bus controllers.</p> <ul style="list-style-type: none"> <li>• Automatic mode recognition (Auto-Negotiation)</li> <li>• Automatic cabling configuration recognition (Auto MDI-X)</li> </ul> <p>Cabling requirement: Category 5, UTP, four-pair cabling</p>
	USB	<p>Four USB 2.0 ports supporting UHCI and EHCI on the rear I/O interface</p>
	Serial	<p>Two 16C550-compatible UARTs on the rear I/O interface, one for RS-232 and one for RS-422 signaling.</p>

Table 1-1: CP6001-R3 Main Specifications (Continued)

CP6001-R3		SPECIFICATIONS
Interfaces	CCPMC	CMC/PMC P1386/Draft 2.4a and CCPMC VITA 20-2001 (R2005) compliant mezzanine interface: <ul style="list-style-type: none"> <li>• CCPMC module support</li> <li>• Jn1, Jn2 and Jn4 PCI mezzanine connectors for standard CCPMC modules</li> <li>• 32-bit/66 MHz PCI/PCI-X interface</li> <li>• Rear I/O supported through the CompactPCI connector J4</li> <li>• Supported voltages: 3.3 V, 5 V, +12 V, and -12 V</li> <li>• Supports 3.3 V signaling voltage (VI/O)</li> </ul>
	Keyboard and Mouse	Keyboard and mouse are supported on rear I/O <ul style="list-style-type: none"> <li>• USB Support</li> <li>• PS/2 (keyboard and mouse)</li> </ul>
	Mass Storage	EIDE ATA: <ul style="list-style-type: none"> <li>• One onboard ATA interface for the soldered CompactFlash</li> <li>• Soldered CompactFlash (true IDE mode, UDMA and Multiword DMA support)</li> </ul> SATA: Integrated Serial ATA Host Controllers <ul style="list-style-type: none"> <li>• Provide independent DMA operation on 4 channels to rear I/O</li> <li>• Data transfer rates up to 300 MB/s</li> </ul>
Sockets	Onboard Connectors	<ul style="list-style-type: none"> <li>• CCPMC connectors J7 to J9 (Jn1, Jn2 and Jn4)</li> <li>• CompactPCI Connectors J1 to J5</li> <li>• J6 - factory use only</li> </ul>
HW Monitoring	Watchdog	Software configurable Watchdog generates IRQ or hardware reset.
	Thermal-Related Functions	Thermal monitor and control: <ul style="list-style-type: none"> <li>• Onboard temperature sensors: <ul style="list-style-type: none"> <li>• Temp1 sensor</li> <li>• Temp2 sensor</li> <li>• Temperature sensor integrated in the Super I/O</li> </ul> </li> <li>• Processor thermal monitoring and regulation: <ul style="list-style-type: none"> <li>• Intel® Thermal Monitor (TM1 and TM2)</li> <li>• Intel® SpeedStep®</li> <li>• Catastrophic cooling failure sensor</li> <li>• Two Digital Thermal Sensors (one per core)</li> <li>• Thermal Diode Sensor</li> </ul> </li> <li>• Conduction cooling</li> </ul>
	System Monitor	SuperIO integrated hardware monitor (SCH3112) for supervision of: <ul style="list-style-type: none"> <li>• Two fan speed inputs</li> <li>• Board temperature</li> </ul>
	IPMI	Baseboard Management Controller (BMC) that supports two keyboard controller-style interfaces (KCS) compliant with: <ul style="list-style-type: none"> <li>• IPMI specification v1.5</li> <li>• PICMG 2.9 specification</li> </ul> IPMI supports two IPMB busses via the J1 and J2 connectors.

Table 1-1: CP6001-R3 Main Specifications (Continued)

CP6001-R3		SPECIFICATIONS
Software	Software BIOS	<p>AMI BIOS with 1 MB Flash memory with the following features:</p> <ul style="list-style-type: none"> <li>• User BIOS defaults (Setup Default Override - SDO)</li> <li>• ACPI support</li> <li>• FWH write protection (BIOS Flash)</li> <li>• Manufacturing data:                             <ul style="list-style-type: none"> <li>• Serial number</li> <li>• Material number</li> <li>• Chipset revision</li> <li>• CPU microcode</li> </ul> </li> <li>• QuickBoot</li> <li>• QuietBoot</li> <li>• LAN boot capability for diskless systems (standard PXE)</li> <li>• Boot from USB floppy disk drive</li> <li>• USB keyboard emulation during BIOS boot</li> <li>• Plug and Play capability</li> <li>• BIOS parameters are saved in the EEPROM</li> <li>• Hardware Health Monitoring</li> </ul>
	Operating Systems	<p>Operating systems supported:</p> <ul style="list-style-type: none"> <li>• Microsoft® Windows® XP</li> <li>• Microsoft® Windows® XP Embedded</li> <li>• Linux</li> <li>• VxWorks</li> </ul> <p>Please contact Kontron for further information concerning the operation of the CP6001-R3 with other operating systems.</p>
General	Mechanical	6U, 4HP, CompactPCI compliant form factor
	Power Consumption	See Chapter 5 for details
	Temperature Ranges	<p>Operational: -40°C to +85°C E2 1.2 MHz version (TPM: -25°C to +70°C)                      -40°C to +70°C E1x 1.5 MHz version (TPM: -25°C to +70°C)</p> <p>Storage: -55°C to +85°C Without any additional components</p> <p> <b>Note ...</b>                      When additional components are installed, refer to their operational specifications as this will influence the operational and storage temperature of the CP6001-R3.</p>
	Climatic Humidity	93% RH at 40°C, non-condensing (acc. to IEC 60068-2-78)
	Dimensions	233.35 mm x 160 mm
Board Weight	750 g (4HP with heat spreader and wedge locks and without a mezzanine board)	



## 1.6 Kontron Software Support

*Kontron* is one of the few CompactPCI and VME manufacturers providing inhouse support for most of the industry-proven real-time operating systems that are currently available. Due to its close relationship with the software manufacturers, *Kontron* is able to produce and support BSPs and drivers for the latest operating system revisions thereby taking advantage of the changes in technology.

## 1.7 Standards

The CP6001-R3 complies with the requirements of the following standards:

**Table 1-2: Standards for the R3 Version**

TYPE	ASPECT	STANDARD	REMARKS
CE	Emission	EN55022 EN61000-6-3	--
	Immission	EN55024 EN61000-6-2	--
	Electrical Safety	EN60950-1	--
Mechanical	Mechanical Dimensions	VITA 30.1	--
Environmental	Climatic Humidity	IEC60068-2-78	--
	WEEE	Directive 2002/96/EC	Waste electrical and electronic equipment
	RoHS	Directive 2002/95/EC	Restriction of the use of certain hazardous substances in electrical and electronic equipment
	Random Vibration (Broadband)	VITA 47 (Class V3)	R3 version test parameters: <ul style="list-style-type: none"> <li>• 5-100 (Hz) frequency range: +3dB slope</li> <li>• 100-1000 (Hz) freq. range: 0.1 (g<sup>2</sup>/Hz)</li> <li>• 1000-2000 (Hz) freq. range: -6dB slope</li> <li>• 60 (min) test duration/axis</li> <li>• 3 axes</li> </ul>
	Single Shock	VITA 47 (Class V3)	R3 version test parameters: <ul style="list-style-type: none"> <li>• 40 (g) acceleration</li> <li>• 11 (ms) pulse duration</li> <li>• 3 shocks per direction</li> <li>• 6 directions</li> <li>• 5 (s) recovery time</li> </ul>
	Temperature	VITA 47, CC3 VITA 47, CC4	1.5 MHz version: -40°C to +70°C 1.2 MHz version: -40°C to +85°C



## 1.8 Related Publications

The following publications contain information relating to this product.

**Table 1-3: Related Publications**

PRODUCT	PUBLICATION
CompactPCI Systems and Boards	CompactPCI Specification 2.0, Rev. 3.0 CompactPCI Packet Switching Backplane Specification PICMG 2.16 Rev. 1.0 CompactPCI System Management Specification PICMG 2.9 Rev. 1.0 CompactPCI Hot Swap Specification PICMG 2.1 Rev. 2.0 (LEDs and hot swap handle switch are not supported) IPMI - Intelligent Platform Management Interface Specification v1.5 <i>Kontron CompactPCI Backplane Manual, ID 24229</i>
CompactFlash Cards	CF+ and CompactFlash Specification Revision 2.1
PMC Modules	Draft Standard for a Common Mezzanine Card Family: CMC, P1386/Draft 2.4a, 21-Mar-01
CCPMC Modules	VITA 20-2001 (R2005)
All Kontron products	Product Safety and Implementation Guide, ID 1021-9142



This page has been intentionally left blank.

