

» User Guide «

CP6004-SA

**6U CompactPCI Processor Board based on
the 3rd Generation Intel® Core™ i7/i5 Processor with
the Intel® QM77 Express Chipset**

Doc. ID: 1052-8529, Rev. 2.0
February 1, 2013



Revision History

Publication Title:		CP6004-SA: 6U CompactPCI Processor Board based on the 3 rd Generation Intel® Core™ i7/i5 Processor with the Intel® QM77 Express Chipset
Doc. ID:		1052-8529
Rev.	Brief Description of Changes	Date of Issue
1.0	Initial issue	20-Sep-2012
2.0	General update, removed information regarding the aluminum heat sink	1-Feb-2013

Imprint

Kontron Europe GmbH may be contacted via the following:

MAILING ADDRESS

Kontron Europe GmbH
 Sudetenstraße 7
 D - 87600 Kaufbeuren Germany

TELEPHONE AND E-MAIL

+49 (0) 800-SALESKONTRON
 sales@kontron.com

For further information about other Kontron products, please visit our Internet website: www.kontron.com.

Disclaimer

Copyright © 2013 Kontron AG. All rights reserved. All data is for information purposes only and not guaranteed for legal purposes. Information has been carefully checked and is believed to be accurate; however, no responsibility is assumed for inaccuracies. Kontron and the Kontron logo and all other trademarks or registered trademarks are the property of their respective owners and are recognized. Specifications are subject to change without notice.





Table of Contents

<i>Revision History</i>	<i>ii</i>
<i>Imprint</i>	<i>ii</i>
<i>Disclaimer</i>	<i>ii</i>
<i>Table of Contents</i>	<i>iii</i>
<i>List of Tables</i>	<i>ix</i>
<i>List of Figures</i>	<i>xi</i>
<i>Proprietary Note</i>	<i>xiii</i>
<i>Trademarks</i>	<i>xiii</i>
<i>Environmental Protection Statement</i>	<i>xiii</i>
<i>Explanation of Symbols</i>	<i>xiv</i>
<i>For Your Safety</i>	<i>xv</i>
<i>High Voltage Safety Instructions</i>	<i>xv</i>
<i>Special Handling and Unpacking Instructions</i>	<i>xv</i>
<i>General Instructions on Usage</i>	<i>xvi</i>
<i>Two Year Warranty</i>	<i>xvii</i>
1. Introduction	1 - 3
1.1 <i>Board Overview</i>	1 - 3
1.2 <i>Board-Specific Information</i>	1 - 4
1.3 <i>System Expansion Capabilities</i>	1 - 5
1.3.1 <i>PMC Module</i>	1 - 5
1.3.2 <i>XMC Module</i>	1 - 5
1.3.3 <i>CP6004-SA-MK2.5SATA Assembly Kit</i>	1 - 5
1.3.4 <i>SATA Flash Module</i>	1 - 5
1.3.5 <i>Rear I/O Module</i>	1 - 5
1.4 <i>Board Diagrams</i>	1 - 5
1.4.1 <i>Functional Block Diagram</i>	1 - 6
1.4.2 <i>Front Panel</i>	1 - 7
1.4.3 <i>Board Layout</i>	1 - 8
1.5 <i>Technical Specification</i>	1 - 10
1.6 <i>Standards</i>	1 - 16
1.7 <i>Related Publications</i>	1 - 17



2. Functional Description	2 - 3
2.1 Processor	2 - 3
2.2 Memory	2 - 4
2.3 Intel® QM77 Express Chipset	2 - 4
2.4 Timer	2 - 5
2.5 Watchdog Timer	2 - 5
2.6 Battery	2 - 5
2.7 Reset	2 - 5
2.8 Flash Memory	2 - 6
2.8.1 SPI Boot Flash for uEFI BIOS	2 - 6
2.8.2 SATA Flash Module (Optional)	2 - 6
2.9 Trusted Platform Module 1.2 (On Request)	2 - 6
2.10 Board Interfaces	2 - 7
2.10.1 Front Panel LEDs	2 - 7
2.10.1.1 IPMI and Hot Swap LEDs	2 - 7
2.10.1.2 Watchdog and Temperature Status LEDs	2 - 8
2.10.1.3 General Purpose LEDs	2 - 9
2.10.2 DIP Switches SW1, SW2 and SW3	2 - 11
2.10.3 USB Interfaces	2 - 12
2.10.3.1 USB Connectors J6 and J7	2 - 12
2.10.4 Integrated Graphics Controller	2 - 12
2.10.4.1 Graphics Memory Usage	2 - 12
2.10.4.2 Analog VGA Connector	2 - 13
2.10.5 COM Ports	2 - 14
2.10.6 Gigabit Ethernet	2 - 15
2.10.7 SATA Interface	2 - 16
2.10.7.1 SATA Connector J14	2 - 16
2.10.8 PMC Interface	2 - 17
2.10.8.1 PMC Connectors J21, J22, J23 and J24 Pinout	2 - 19
2.10.9 XMC Interface	2 - 21
2.10.10 Debug Interface	2 - 22
2.10.11 CompactPCI Interface	2 - 22
2.10.11.1 Board Functionality when Installed in System Slot	2 - 22
2.10.11.2 Board Functionality when Installed in Peripheral Slot	2 - 23



2.10.11.3	<i>Packet Switching Backplane (PICMG 2.16)</i>	2 - 23
2.10.11.4	<i>Hot Swap Support</i>	2 - 23
2.10.11.5	<i>Power Ramping</i>	2 - 23
2.10.11.6	<i>Precharge</i>	2 - 23
2.10.11.7	<i>Handle Switch</i>	2 - 23
2.10.11.8	<i>ENUM# Interrupt</i>	2 - 23
2.10.11.9	<i>Hot Swap LED</i>	2 - 23
2.10.12	<i>CompactPCI Bus Connector</i>	2 - 24
2.10.12.1	<i>CompactPCI Connector Keying</i>	2 - 24
2.10.12.2	<i>CompactPCI Connectors J1 and J2 Pinout</i>	2 - 25
2.10.12.3	<i>CompactPCI Rear I/O Connectors J3-J5 and Pinout</i>	2 - 29
3.	<i>Installation</i>	3 - 3
3.1	<i>Safety Requirements</i>	3 - 3
3.2	<i>CP6004-SA Initial Installation Procedures</i>	3 - 4
3.3	<i>Standard Removal Procedures</i>	3 - 5
3.4	<i>Hot Swap Procedures</i>	3 - 6
3.4.1	<i>System Master Hot Swap</i>	3 - 6
3.4.2	<i>Peripheral Hot Swap Procedure</i>	3 - 6
3.5	<i>Installation of CP6004-SA Peripheral Devices</i>	3 - 8
3.5.1	<i>USB Device Installation</i>	3 - 9
3.5.2	<i>SATA Flash Module Installation</i>	3 - 9
3.5.3	<i>Installation of External SATA Devices</i>	3 - 9
3.5.4	<i>Onboard 2.5" HDD/SSD Installation</i>	3 - 9
3.6	<i>PMC/XMC Module Installation</i>	3 - 10
3.6.1	<i>Rear I/O Device Installation</i>	3 - 10
3.7	<i>Battery Replacement</i>	3 - 11
3.8	<i>Software Installation</i>	3 - 11
4.	<i>Configuration</i>	4 - 3
4.1	<i>DIP Switches SW1, SW2 and SW3 Configuration</i>	4 - 3
4.1.1	<i>DIP Switch SW1 Configuration</i>	4 - 3
4.1.2	<i>DIP Switches SW2 and SW3 Configuration</i>	4 - 4



- 4.2 Jumper Description 4 - 5
- 4.3 I/O Address Map 4 - 5
- 4.4 CP6004-SA-Specific Registers 4 - 6
 - 4.4.1 Status Register 0 (STAT0) 4 - 6
 - 4.4.2 Status Register 1 (STAT1) 4 - 7
 - 4.4.3 Control Register 0 (CTRL0) 4 - 8
 - 4.4.4 Control Register 1 (CTRL1) 4 - 8
 - 4.4.5 Device Protection Register (DPROT) 4 - 9
 - 4.4.6 Reset Status Register (RSTAT) 4 - 10
 - 4.4.7 Board Interrupt Configuration Register (BICFG) 4 - 11
 - 4.4.8 Status Register 2 (STAT2) 4 - 12
 - 4.4.9 Board ID High Byte Register (BIDH) 4 - 12
 - 4.4.10 Board and PLD Revision Register (BREV) 4 - 13
 - 4.4.11 Geographic Addressing Register (GEOAD) 4 - 13
 - 4.4.12 Watchdog Timer Control Register (WTIM) 4 - 14
 - 4.4.13 Board ID Low Byte Register (BIDL) 4 - 16
 - 4.4.14 LED Configuration Register (LCFG) 4 - 17
 - 4.4.15 LED Control Register (LCTRL) 4 - 18
 - 4.4.16 General Purpose Output Register (GPOUT) 4 - 19
 - 4.4.17 General Purpose Input Register (GPIN) 4 - 19
 - 4.4.18 IPMI Keyboard Controller Style Interface 4 - 19

5. Power Considerations 5 - 3

- 5.1 System Power 5 - 3
 - 5.1.1 CP6004-SA Baseboard 5 - 3
 - 5.1.2 Backplane 5 - 4
 - 5.1.3 Power Supply Units 5 - 4
 - 5.1.3.1 Start-Up Requirement 5 - 4
 - 5.1.3.2 Power-Up Sequence 5 - 4
 - 5.1.3.3 Tolerance 5 - 5
 - 5.1.3.4 Regulation 5 - 5
- 5.2 Power Consumption 5 - 6
 - 5.2.1 Power Consumption of the CP6004-SA Accessories 5 - 8
 - 5.2.2 Power Consumption per Gigabit Ethernet Port 5 - 8



5.3	<i>Maximum Power Consumption of PMC Module</i>	5 - 8
5.4	<i>Maximum Power Consumption of XMC Modules</i>	5 - 9
6.	<i>Thermal Considerations</i>	6 - 3
6.1	<i>Board Internal Thermal Monitoring</i>	6 - 3
6.2	<i>Processor Thermal Monitoring</i>	6 - 3
6.2.1	<i>Digital Thermal Sensor (DTS)</i>	6 - 3
6.2.2	<i>Adaptive Thermal Monitor</i>	6 - 4
6.2.2.1	<i>Frequency/sVID Control</i>	6 - 4
6.2.2.2	<i>Clock Modulation</i>	6 - 4
6.2.3	<i>Catastrophic Cooling Failure Sensor</i>	6 - 5
6.3	<i>Chipset Thermal Monitor Feature</i>	6 - 5
6.4	<i>External Thermal Regulation</i>	6 - 5
6.4.1	<i>Operational Limits for the CP6004-SA</i>	6 - 7
6.4.2	<i>Peripherals</i>	6 - 9
A.	<i>CP6004-SA-MK2.5-SATA Assembly Kit</i>	A - 3
A.1	<i>MMADP-SATA01 Module Overview</i>	A - 3
A.2	<i>Technical Specifications</i>	A - 3
A.3	<i>MMADP-SATA01 Module Layout</i>	A - 4
A.4	<i>SATA Connector J2</i>	A - 5
B.	<i>SATA Flash Module</i>	B - 3
B.1	<i>Technical Specifications</i>	B - 3
B.2	<i>SATA Flash Module Layout</i>	B - 4



This page has been intentionally left blank.





List of Tables

1-1	<i>CP6004-SA Main Specifications</i>	1 - 10
1-2	<i>Standards</i>	1 - 16
1-3	<i>Related Publications</i>	1 - 17
2-1	<i>Features of the Processors Supported on the CP6004-SA</i>	2 - 4
2-2	<i>IPMI and Hot Swap LEDs Function</i>	2 - 7
2-3	<i>Watchdog and Temperature Status LEDs Function</i>	2 - 8
2-4	<i>General Purpose LEDs Function</i>	2 - 9
2-5	<i>POST Code Sequence</i>	2 - 10
2-6	<i>POST Code Example</i>	2 - 10
2-7	<i>DIP Switch SW1 Function</i>	2 - 11
2-8	<i>DIP Switch SW2 Function</i>	2 - 11
2-9	<i>DIP Switch SW3 Function</i>	2 - 11
2-10	<i>USB Connectors J6 and J7 Pinout</i>	2 - 12
2-11	<i>D-Sub VGA Connector J9 Pinout</i>	2 - 13
2-12	<i>Serial Connector J8 (COMA) Pinout</i>	2 - 14
2-13	<i>Gigabit Ethernet Port Mapping</i>	2 - 15
2-14	<i>Pinout of Gigabit Ethernet Connectors J10, J11 and J12</i>	2 - 15
2-15	<i>SATA Connector J14 Pinout</i>	2 - 16
2-16	<i>PMC PCI/PCI-X Configuration</i>	2 - 17
2-17	<i>PMC Connectors J22 and J24 Pinout</i>	2 - 19
2-18	<i>PMC Connectors J21 and J23 Pinout</i>	2 - 20
2-19	<i>XMC Connector J20 Pinout</i>	2 - 21
2-20	<i>CompactPCI PCI/PCI-X Configuration</i>	2 - 22
2-21	<i>CompactPCI Bus Connector J1 System Slot Pinout</i>	2 - 25
2-22	<i>CompactPCI Bus Connector J1 Peripheral Slot Pinout</i>	2 - 26
2-23	<i>64-bit CompactPCI Bus Connector J2 System Slot Pinout</i>	2 - 27
2-24	<i>64-bit CompactPCI Bus Connector J2 Peripheral Slot Pinout</i>	2 - 28
2-25	<i>CompactPCI Rear I/O Connector J3 Pinout</i>	2 - 29
2-26	<i>CompactPCI Rear I/O Connector J3 Signals</i>	2 - 30
2-27	<i>CompactPCI Rear I/O Connector J4 Pinout</i>	2 - 31
2-28	<i>CompactPCI Rear I/O Connector J5 Pinout</i>	2 - 32
2-29	<i>CompactPCI Rear I/O Connector J5 Signals</i>	2 - 32
4-1	<i>DIP Switch SW1 for Boot Configuration</i>	4 - 3



4-2	<i>DIP Switch SW2 for CompactPCI Interface Configuration</i>	4 - 4
4-3	<i>DIP Switch SW3 for PMC Interface Configuration</i>	4 - 4
4-4	<i>I/O Address Map</i>	4 - 5
4-5	<i>Status Register 0 (STAT0)</i>	4 - 6
4-6	<i>Status Register 1 (STAT1)</i>	4 - 7
4-7	<i>Control Register 0 (CTRL0)</i>	4 - 8
4-8	<i>Control Register 1 (CTRL1)</i>	4 - 8
4-9	<i>Device Protection Register (DPROT)</i>	4 - 9
4-10	<i>Reset Status Register (RSTAT)</i>	4 - 10
4-11	<i>Board Interrupt Configuration Register (BICFG)</i>	4 - 11
4-12	<i>Status Register 2 (STAT2)</i>	4 - 12
4-13	<i>Board ID High Byte Register (BIDH)</i>	4 - 12
4-14	<i>Board and PLD Revision Register (BREV)</i>	4 - 13
4-15	<i>Geographic Addressing Register (GEOAD)</i>	4 - 13
4-16	<i>Watchdog Timer Control Register (WTIM)</i>	4 - 15
4-17	<i>Board ID Low Byte Register (BIDL)</i>	4 - 16
4-18	<i>LED Configuration Register (LCFG)</i>	4 - 17
4-19	<i>LED Control Register (LCTRL)</i>	4 - 18
4-20	<i>General Purpose Output Register (GPOUT)</i>	4 - 19
4-21	<i>General Purpose Input Register (GPIN)</i>	4 - 19
5-1	<i>Maximum Input Power Voltage Limits</i>	5 - 3
5-2	<i>DC Operational Input Voltage Ranges</i>	5 - 3
5-3	<i>Input Voltage Characteristics</i>	5 - 5
5-4	<i>CP6004-SA in uEFI Shell Mode</i>	5 - 7
5-5	<i>CP6004-SA with Win. 7 and Processor and Graphics in Idle State</i>	5 - 7
5-6	<i>CP6004-SA with Win. 7 and Max. Proc. Workload and Basic Graphics Oper.</i>	5 - 7
5-7	<i>CP6004-SA with Win. 7 and Max. Processor and Graphics Workload</i>	5 - 7
5-8	<i>Power Consumption of CP6004-SA Accessories</i>	5 - 8
5-9	<i>Power Consumption per Gigabit Ethernet Port</i>	5 - 8
5-10	<i>PMC Module Current</i>	5 - 8
5-11	<i>XMC Module Current</i>	5 - 9
A-1	<i>MMADP-SATA01 Main Specifications</i>	A - 3
A-2	<i>SATA Connector J2 Pinout</i>	A - 5
B-1	<i>SATA Flash Module Main Specifications</i>	B - 3





List of Figures

1-1	<i>CP6004-SA Functional Block Diagram</i>	1 - 6
1-2	<i>CP6004-SA Front Panel</i>	1 - 7
1-3	<i>CP6004-SA Board Layout – Top View</i>	1 - 8
1-4	<i>CP6004-SA Board Layout – Bottom View</i>	1 - 9
2-1	<i>USB Connectors J6 and J7</i>	2 - 12
2-2	<i>D-Sub VGA Connector J9</i>	2 - 13
2-3	<i>Serial Connector J8 (COMA)</i>	2 - 14
2-4	<i>Gigabit Ethernet Connectors J10, J11 and J12</i>	2 - 15
2-5	<i>SATA Connector J14</i>	2 - 16
2-6	<i>PMC Connectors J21, J22, J23 and J24</i>	2 - 18
2-7	<i>XMC Connector J20</i>	2 - 21
2-8	<i>CompactPCI Connectors J1-J5</i>	2 - 24
3-1	<i>Connecting a Peripheral Device to the CP6004-SA</i>	3 - 8
4-1	<i>DIP Switch SW1</i>	4 - 3
4-2	<i>DIP Switches SW2 and SW3</i>	4 - 4
6-1	<i>CP6004-SA with Core™ i7-3615QE (SV) 2.3 GHz</i>	6 - 7
6-2	<i>CP6004-SA with Core™ i7-3612QE (SV) 2.1 GHz</i>	6 - 7
6-3	<i>CP6004-SA with Core™ i7-3555LE (LV) 2.5 GHz</i>	6 - 8
6-4	<i>CP6004-SA with Core™ i5-3610ME (SV) 2.7 GHz</i>	6 - 8
A-1	<i>MMADP-SATA01 Module Layout</i>	A - 4
A-2	<i>SATA Connector J2</i>	A - 5
B-1	<i>SATA Flash Module Layout (Bottom View)</i>	B - 4



This page has been intentionally left blank.





Proprietary Note

This document contains information proprietary to Kontron. It may not be copied or transmitted by any means, disclosed to others, or stored in any retrieval system or media without the prior written consent of Kontron or one of its authorized agents.

The information contained in this document is, to the best of our knowledge, entirely correct. However, Kontron cannot accept liability for any inaccuracies or the consequences thereof, or for any liability arising from the use or application of any circuit, product, or example shown in this document.

Kontron reserves the right to change, modify, or improve this document or the product described herein, as seen fit by Kontron without further notice.

Trademarks

Kontron, the *PEP* logo and, if occurring in this manual, “CXM” are trademarks owned by Kontron, Kaufbeuren (Germany). In addition, this document may include names, company logos and trademarks, which are registered trademarks and, therefore, proprietary to their respective owners.

Environmental Protection Statement

This product has been manufactured to satisfy environmental protection requirements where possible. Many of the components used (structural parts, printed circuit boards, connectors, batteries, etc.) are capable of being recycled.

Final disposition of this product after its service life must be accomplished in accordance with applicable country, state, or local laws or regulations.



Explanation of Symbols



Caution, Electric Shock!

This symbol and title warn of hazards due to electrical shocks (> 60V) when touching products or parts of them. Failure to observe the precautions indicated and/or prescribed by the law may endanger your life/health and/or result in damage to your material.

Please refer also to the section “High Voltage Safety Instructions” on the following page.



Warning, ESD Sensitive Device!

This symbol and title inform that electronic boards and their components are sensitive to static electricity. Therefore, care must be taken during all handling operations and inspections of this product, in order to ensure product integrity at all times.

Please read also the section “Special Handling and Unpacking Instructions” on the following page.



Warning!

This symbol and title emphasize points which, if not fully understood and taken into consideration by the reader, may endanger your health and/or result in damage to your material.



Note ...

This symbol and title emphasize aspects the reader should read through carefully for his or her own advantage.



For Your Safety

Your new Kontron product was developed and tested carefully to provide all features necessary to ensure its compliance with electrical safety requirements. It was also designed for a long fault-free life. However, the life expectancy of your product can be drastically reduced by improper treatment during unpacking and installation. Therefore, in the interest of your own safety and of the correct operation of your new Kontron product, you are requested to conform with the following guidelines.

High Voltage Safety Instructions



Warning!

All operations on this device must be carried out by sufficiently skilled personnel only.



Caution, Electric Shock!

Before installing a not hot-swappable Kontron product into a system always ensure that your mains power is switched off. This applies also to the installation of piggybacks.

Serious electrical shock hazards can exist during all installation, repair and maintenance operations with this product. Therefore, always unplug the power cable and any other cables which provide external voltages before performing work.

Special Handling and Unpacking Instructions



ESD Sensitive Device!

Electronic boards and their components are sensitive to static electricity. Therefore, care must be taken during all handling operations and inspections of this product, in order to ensure product integrity at all times.

Do not handle this product out of its protective enclosure while it is not used for operational purposes unless it is otherwise protected.

Whenever possible, unpack or pack this product only at EOS/ESD safe work stations. Where a safe work station is not guaranteed, it is important for the user to be electrically discharged before touching the product with his/her hands or tools. This is most easily done by touching a metal part of your system housing.

It is particularly important to observe standard anti-static precautions when changing piggybacks, ROM devices, jumper settings etc. If the product contains batteries for RTC or memory backup, ensure that the board is not placed on conductive surfaces, including anti-static plastics or sponges. They can cause short circuits and damage the batteries or conductive circuits on the board.



General Instructions on Usage

In order to maintain Kontron's product warranty, this product must not be altered or modified in any way. Changes or modifications to the device, which are not explicitly approved by Kontron and described in this manual or received from Kontron's Technical Support as a special handling instruction, will void your warranty.

This device should only be installed in or connected to systems that fulfill all necessary technical and specific environmental requirements. This applies also to the operational temperature range of the specific board version, which must not be exceeded. If batteries are present, their temperature restrictions must be taken into account.

In performing all necessary installation and application operations, please follow only the instructions supplied by the present manual.

Keep all the original packaging material for future storage or warranty shipments. If it is necessary to store or ship the board, please re-pack it as nearly as possible in the manner in which it was delivered.

Special care is necessary when handling or unpacking the product. Please consult the special handling and unpacking instruction on the previous page of this manual.



Two Year Warranty

Kontron grants the original purchaser of Kontron's products a **TWO YEAR LIMITED HARDWARE WARRANTY** as described in the following. However, no other warranties that may be granted or implied by anyone on behalf of Kontron are valid unless the consumer has the express written consent of Kontron.

Kontron warrants their own products, excluding software, to be free from manufacturing and material defects for a period of 24 consecutive months from the date of purchase. This warranty is not transferable nor extendible to cover any other users or long-term storage of the product. It does not cover products which have been modified, altered or repaired by any other party than Kontron or their authorized agents. Furthermore, any product which has been, or is suspected of being damaged as a result of negligence, improper use, incorrect handling, servicing or maintenance, or which has been damaged as a result of excessive current/voltage or temperature, or which has had its serial number(s), any other markings or parts thereof altered, defaced or removed will also be excluded from this warranty.

If the customer's eligibility for warranty has not been voided, in the event of any claim, he may return the product at the earliest possible convenience to the original place of purchase, together with a copy of the original document of purchase, a full description of the application the product is used on and a description of the defect. Pack the product in such a way as to ensure safe transportation (see our safety instructions).

Kontron provides for repair or replacement of any part, assembly or sub-assembly at their own discretion, or to refund the original cost of purchase, if appropriate. In the event of repair, refunding or replacement of any part, the ownership of the removed or replaced parts reverts to Kontron, and the remaining part of the original guarantee, or any new guarantee to cover the repaired or replaced items, will be transferred to cover the new or repaired items. Any extensions to the original guarantee are considered gestures of goodwill, and will be defined in the "Repair Report" issued by Kontron with the repaired or replaced item.

Kontron will not accept liability for any further claims resulting directly or indirectly from any warranty claim, other than the above specified repair, replacement or refunding. In particular, all claims for damage to any system or process in which the product was employed, or any loss incurred as a result of the product not functioning at any given time, are excluded. The extent of Kontron liability to the customer shall not exceed the original purchase price of the item for which the claim exists.

Kontron issues no warranty or representation, either explicit or implicit, with respect to its products' reliability, fitness, quality, marketability or ability to fulfil any particular application or purpose. As a result, the products are sold "as is," and the responsibility to ensure their suitability for any given task remains that of the purchaser. In no event will Kontron be liable for direct, indirect or consequential damages resulting from the use of our hardware or software products, or documentation, even if Kontron were advised of the possibility of such claims prior to the purchase of the product or during any period since the date of its purchase.

Please remember that no Kontron employee, dealer or agent is authorized to make any modification or addition to the above specified terms, either verbally or in any other form, written or electronically transmitted, without the company's consent.



This page has been intentionally left blank.





Chapter

1

Introduction



This page has been intentionally left blank.





1. Introduction

1.1 Board Overview

The CP6004-SA (Standard Air-Cooled) is a highly integrated 6U CompactPCI system controller board based on the 3rd generation Intel® Core™ i7 and i5 processors combined with the mobile Intel® QM77 Express Chipset.

The board supports the Intel® Core™ i7-3615QE quad-core processor with 2.3 GHz, the Intel® Core™ i7-3612QE quad-core processor with 2.1 GHz, the Intel® Core™ i7-3555LE dual-core processor with 2.5 GHz, and the Intel® Core™ i5-3610ME dual-core processor with 2.7 GHz. All processors are built on 22-nm technology and provided in a BGA package. The processor is soldered on the CP6004-SA which results in a higher Mean Time Between Failures (MTBF) and a significant improvement in cooling.

Two SODIMM sockets are available on the CP6004-SA to provide up to 16 GB dual-channel, DDR3 memory with Error Checking and Correction (ECC) running at 1600 MHz. The graphics controller and the memory controller are integrated in the processor. Furthermore, either one 2.5" HDD/SSD or up to 64 GB NAND flash memory (SSD) via a SATA Flash module can be integrated onto the CP6004-SA.

For maximum application flexibility, the CP6004-SA comes with an extensive range of interfaces such as up to five Gigabit Ethernet ports (three on front I/O and two on rear I/O in compliance with PICMG 2.16), three high-resolution graphics interfaces (VGA, 2 x HDMI/DVI), two COM ports (RS-232 on front and rear I/O), and six SATA interfaces with RAID 0/1/5/10 functionality, one for the onboard SATA connector, one for the SATA Flash module or the 2.5" HDD/SSD, and four for rear I/O. In addition, six USB 2.0 ports are available on the board, two on front I/O and four on rear I/O.

Support for one PMC/XMC module ensures individual system expansion either via one 64-bit/66 MHz PCI or 64-bit/133 MHz PCI-X PMC interface or via one XMC interface utilizing a x8 lane PCI Express 2.0 interconnection.

The board supports a configurable 64-bit/66 MHz PCI or PCI-X hot swap CompactPCI interface. When installed in the system slot, the interface is enabled, and when installed in a peripheral slot, the CP6004-SA is isolated from the CompactPCI bus.

Safety and security features via a Trusted Platform Module (TPM) 1.2 are provided on request. Intelligent Platform Management Interface (IPMI) is supported as well.

Designed for stability, the board fits into applications situated in industrial environments, including I/O intensive applications where only one slot is available for the CPU, making it a perfect core technology for long-life applications. Components with high temperature tolerance have been selected from embedded technology programs, and therefore offer long-term availability.

The board is offered with various Board Support Packages including Windows, VxWorks and Linux operating systems. For further information concerning the operating systems available for the CP6004-SA, please contact Kontron.



1.2 Board-Specific Information

The CP6004-SA is a CompactPCI single-board computer based on the 3rd generation Intel® Core™ i7 and i5 processors and specifically designed for use in highly integrated platforms with solid mechanical interfacing for a wide range of industrial environment applications.

Some of the CP6004-SA's outstanding features are:

- Support for the following 3rd generation processors:
 - Intel® Core™ i7-3615QE (SV) quad-core processor, 2.3 GHz, 6 MB L3 cache
 - Intel® Core™ i7-3612QE (SV) quad-core processor, 2.1 GHz, 6 MB L3 cache
 - Intel® Core™ i7-3555LE (LV) dual-core processor, 2.5 GHz, 4 MB L3 cache
 - Intel® Core™ i5-3610ME (SV) dual-core processor, 2.7 GHz, 3 MB L3 cache
- Intel® QM77 Express Chipset
- Up to 16 GB, dual-channel, DDR3 SDRAM memory with ECC running at 1600 MHz on two SODIMM sockets
- Integrated 3D high-performance graphics controller with three high-resolution graphics interfaces (VGA, 2 x HDMI/DVI)
- 64-bit/66 MHz PCI or PCI-X CompactPCI interface (PICMG 2.0)
- One PMC slot with PCI functionality and with rear I/O support; 64-bit/66 MHz PCI interface or 64-bit/133 MHz PCI-X interface
- One XMC slot utilizing a x8 lane PCI Express 2.0 interconnection
- Five Gigabit Ethernet interfaces:
 - Three Gigabit Ethernet interfaces on front I/O
 - Two Gigabit Ethernet interfaces on rear I/O (PICMG 2.16)
- Two Gigabit Ethernet (GbE) controllers:
 - One Intel® 82579LM Gigabit Ethernet controller connected to one GbE port on the front panel
 - One Intel® I350 quad-port Gigabit Ethernet controller connected to two GbE ports on the front panel and two GbE ports on the rear I/O
- Six SATA interfaces with SATA RAID 0/1/5/10 support:
 - One onboard SATA 6 Gb/s interface for the standard SATA onboard connector
 - One onboard SATA 6 Gb/s interface for either one SATA Flash module or one SATA 2.5" HDD/SSD
 - Four SATA 3 Gb/s interfaces on the rear I/O
- Six USB ports:
 - Two USB 2.0 ports on the front panel
 - Four USB 2.0 ports on the rear I/O
- Two COM ports:
 - One RS-232 COM port either on the front panel or on the rear I/O (COMA)
 - One RS-232 COM port on the rear I/O (COMB)
- TCG 1.2 compliant Trusted Platform Module (TPM), on request
- Two SPI boot flashes for two separate uEFI BIOS images:
 - One standard SPI boot flash
 - One recovery SPI boot flash
- Watchdog timer
- Battery-backed real-time clock (RTC)
- Three onboard DIP switches for board configuration
- Supports PICMG Packet Switching Backplane Specification 2.16
- IPMI support
- 4HP, 6U CompactPCI
- Passive heat sink solution for forced-airflow cooling



- Rear I/O on J3 and J5; optionally on J4 for PMC/XMC only
- Hot swap capability: as system controller or as peripheral device
- AMI Aptio®, a uEFI-compliant platform firmware

1.3 System Expansion Capabilities

1.3.1 PMC Module

The CP6004-SA has a 3.3 V, rear I/O capable PMC mezzanine interface configurable for either 64-bit/66 MHz PCI or 64-bit/133 MHz PCI-X operation. This interface supports a wide range of PMC modules with PCI interface including all of Kontron's PMC modules and provides an easy and flexible way to configure the CP6004-SA for various application requirements. For information on the PMC interface, refer to chapter 2.10.8, "PMC Interface".

1.3.2 XMC Module

The CP6004-SA has one XMC mezzanine interface for support of x1, x4 and x8 PCI Express 2.0 XMC modules providing an easy and flexible way to configure the CP6004-SA for various application requirements. For information on the XMC interface, refer to chapter 2.10.9, "XMC Interface".

1.3.3 CP6004-SA-MK2.5SATA Assembly Kit

The CP6004-SA comes with an optional CP6004-SA-MK2.5SATA assembly kit comprised of one MMADP-SATA01 module and the necessary components needed for mounting the module on the CP6004-SA. The MMADP-SATA01 module is required for connecting an onboard 2.5" SATA HDD or SSD to the CP6004-SA via an onboard SATA extension connector. For further information concerning the MMADP-SATA01 module, please refer to Appendix A.

1.3.4 SATA Flash Module

The CP6004-SA provides support for up to 64 GB NAND flash memory in combination with an optional SATA Flash module, which is connected to the CP6004-SA via an onboard SATA extension connector. For further information concerning the SATA Flash module, please refer to Appendix B.

1.3.5 Rear I/O Module

The CP6004-SA provides support for one rear I/O module via the CompactPCI rear I/O connectors. For further information about the compatibility of rear I/O modules with the CP6004-SA, please refer to the CP6004-SA datasheet.

1.4 Board Diagrams

The following diagrams provide additional information concerning board functionality and component layout.

1.4.1 Functional Block Diagram

Figure 1-1: CP6004-SA Functional Block Diagram

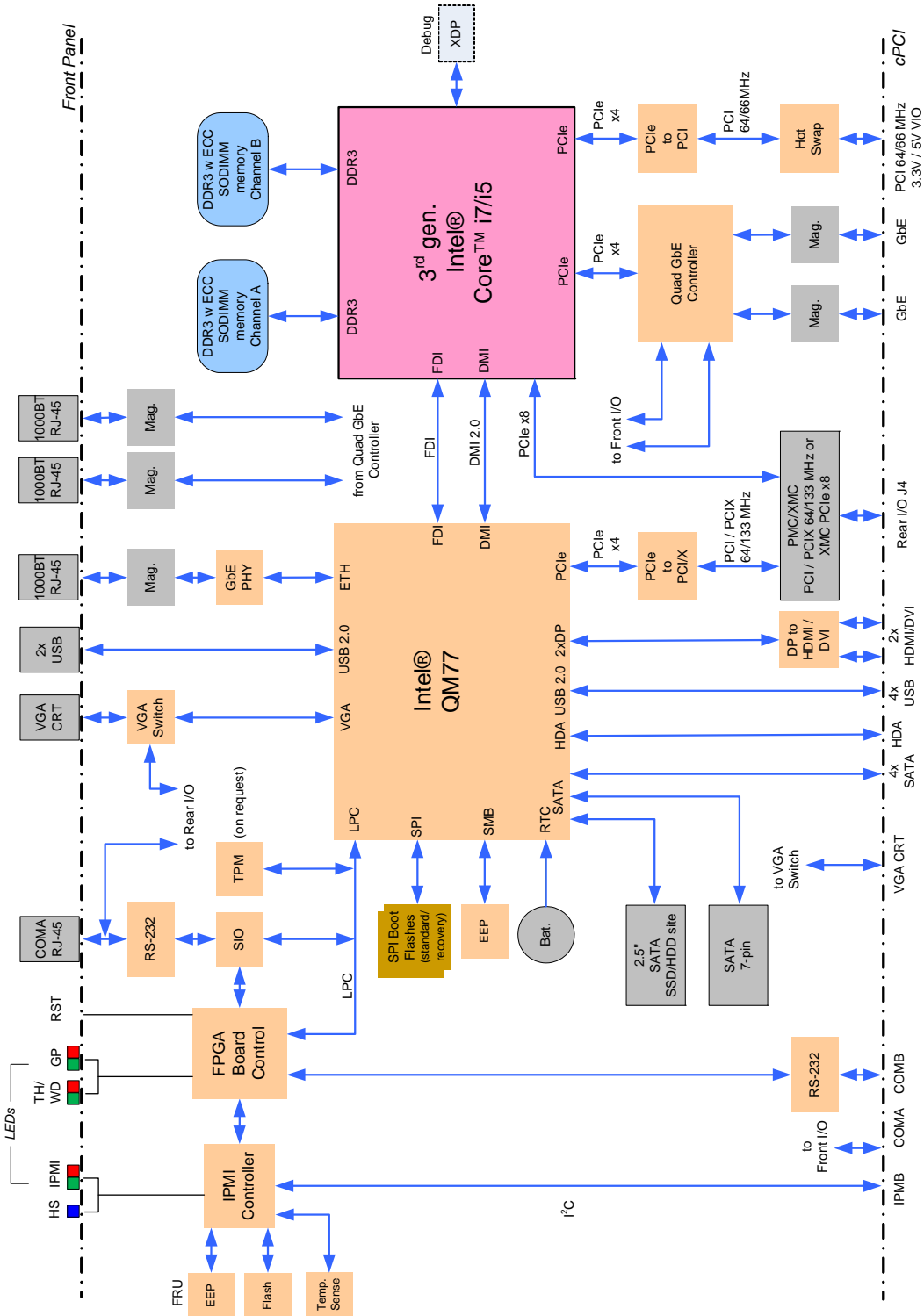



1.4.2 Front Panel

Figure 1-2: CP6004-SA Front Panel

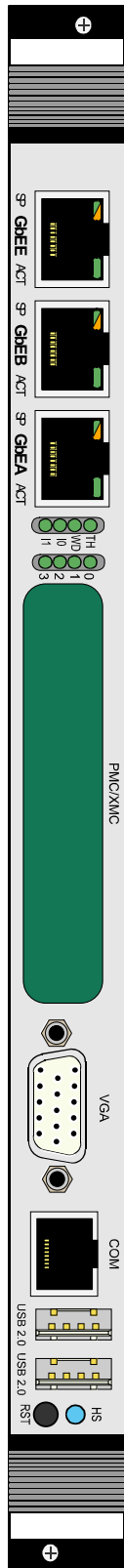

Legend

IPMI LEDs

I0/I1 (red/green): Indicate the software status of the IPMI controller

Status LEDs

WD (green): Watchdog Status

TH (red/green): Temperature Status

HS (blue): Hot Swap Control

Integral Ethernet LEDs

ACT (green): Ethernet Link/Activity

SPEED (green/orange/off): Ethernet Speed

General Purpose LEDs

LED 0..3 (red/green/amber): General Purpose/POST code



Note ...

If the General Purpose LEDs are lit red during boot-up, a failure is indicated before the uEFI BIOS has started.

For further information, please contact Kontron.

1.4.3 Board Layout

Figure 1-3: CP6004-SA Board Layout – Top View

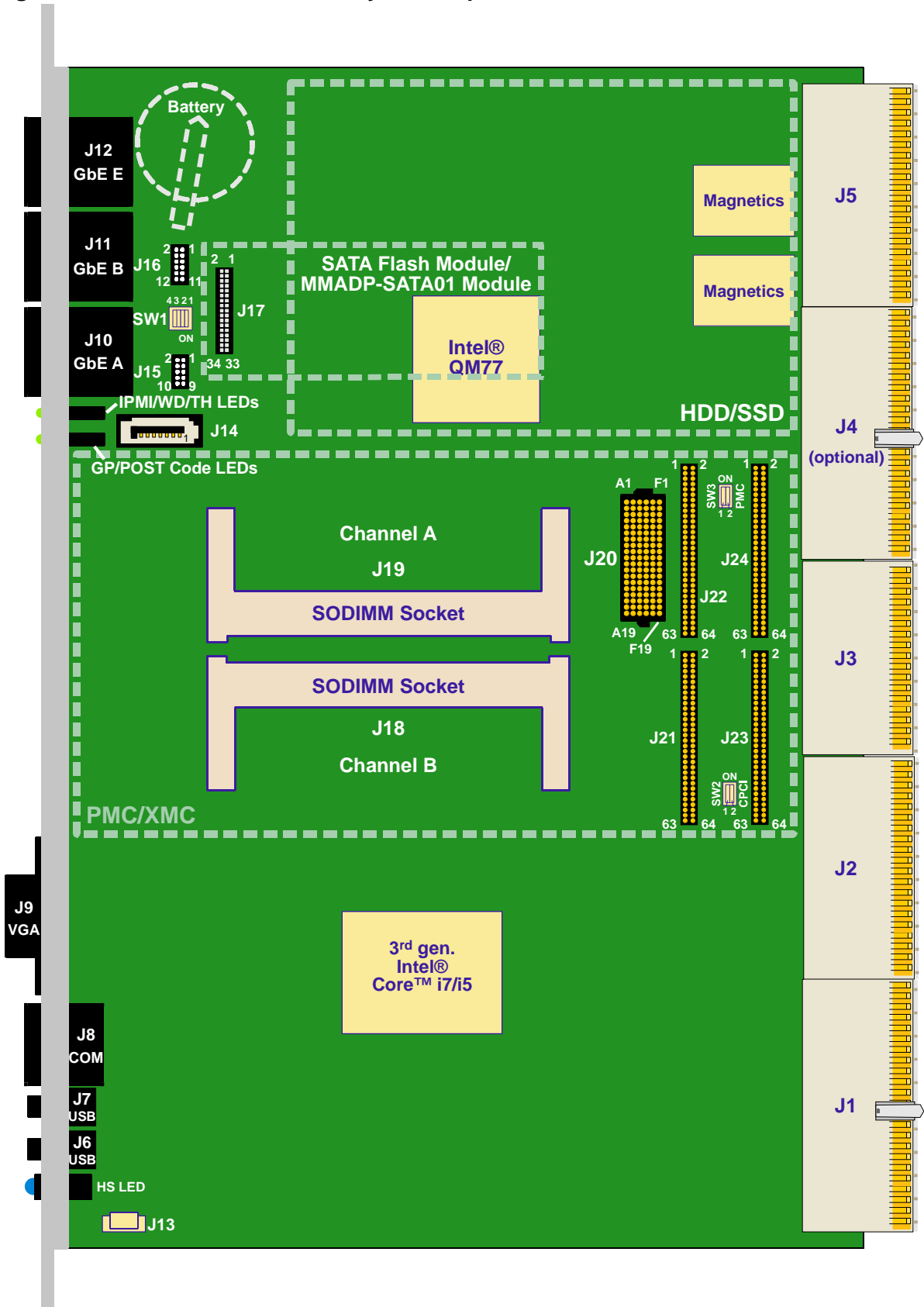
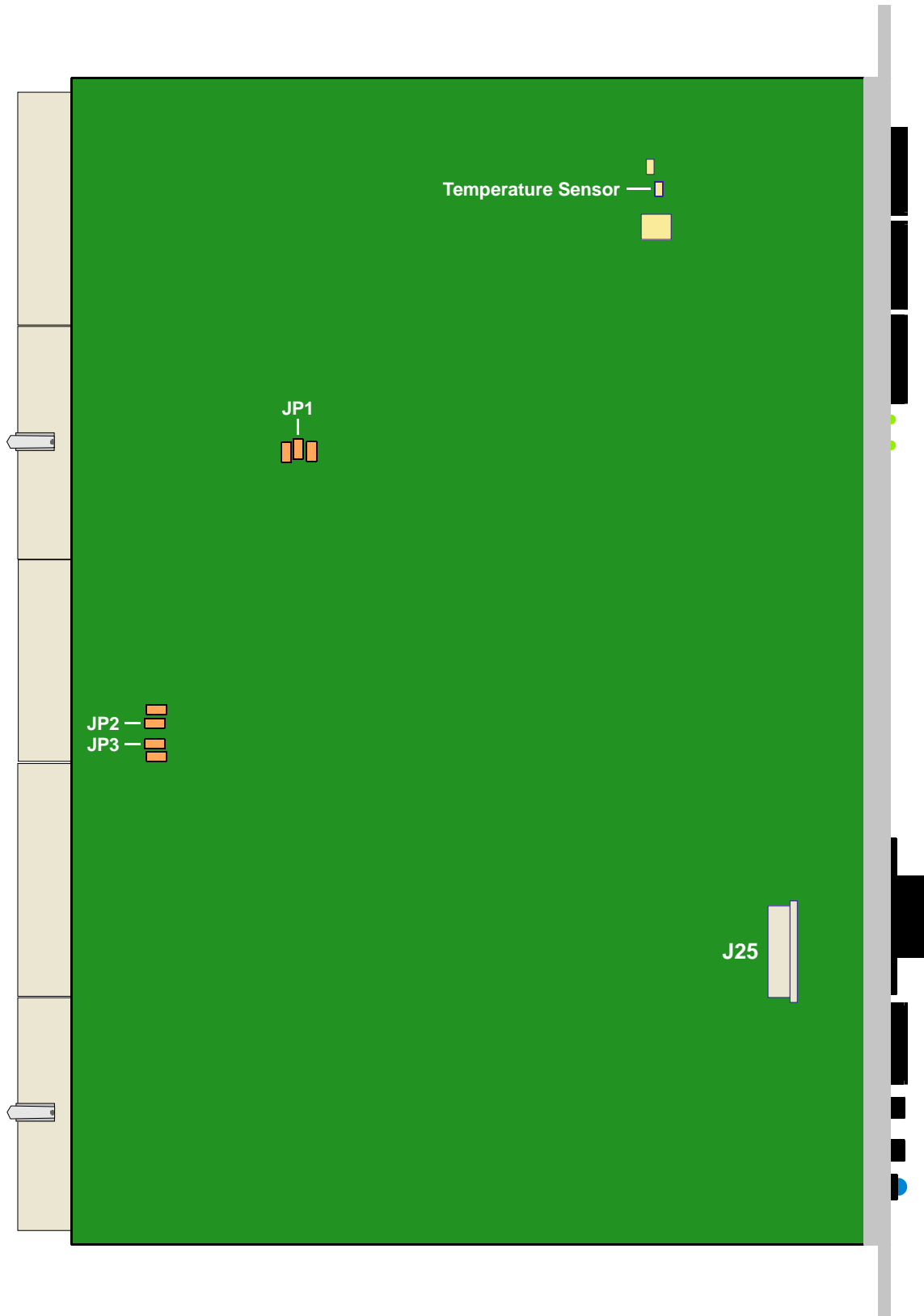



Figure 1-4: CP6004-SA Board Layout – Bottom View



1.5 Technical Specification

Table 1-1: CP6004-SA Main Specifications

FEATURES		SPECIFICATIONS
Processor and Memory	CPU	<p>The CP6004-SA supports the following 3rd generation microprocessors:</p> <ul style="list-style-type: none"> • Intel® Core™ i7-3615QE (SV) quad-core processor, 2.3 GHz, 6 MB L3 cache • Intel® Core™ i7-3612QE (SV) quad-core processor, 2.1 GHz, 6 MB L3 cache • Intel® Core™ i7-3555LE (LV) dual-core processor, 2.5 GHz, 4 MB L3 cache • Intel® Core™ i5-3610ME (SV) dual-core processor, 2.7 GHz, 3 MB L3 cache <p>Further processor features:</p> <ul style="list-style-type: none"> • Up to four execution cores • Intel® Hyper-Threading Technology (Intel® HT Technology) • Intel® 64 Architecture • Intel® Advanced Vector Extensions (AVX) floating point • Intel® Turbo Boost Technology 2.0 • Intel® Intelligent Power Sharing (IPS) • System memory interface with optimized support for dual-channel DDR3 SDRAM memory at 1600 MHz with ECC • Integrated 2D and 3D Graphics Engines • DMI 2.0 with 5 GT/s and FDI interfaces to the Intel® QM77 Chipset • One x8 and two x4 PCI Express 2.0 ports operating at 5 GT/s <p>Please contact Kontron for further information concerning the suitability of other Intel processors for use with the CP6004-SA.</p>
	Memory	<p>Main memory:</p> <ul style="list-style-type: none"> • Up to 16 GB, dual-channel DDR3 SDRAM memory with ECC running at 1600 MHz on two SODIMM sockets <p>Cache structure:</p> <ul style="list-style-type: none"> • 64 kB L1 cache for each core <ul style="list-style-type: none"> • 32 kB instruction cache • 32 kB data cache • 256 kB L2 shared instruction/data cache for each core • Up to 6 MB L3 shared instruction/data cache <p>Flash memory:</p> <ul style="list-style-type: none"> • Two SPI boot flash chips (2 x 8 MB) for two separate uEFI BIOS images • Up to 64 GB NAND flash via an onboard SATA Flash module (SSD) <p>Serial EEPROM with 64 kbit</p>

Table 1-1: CP6004-SA Main Specifications (Continued)

FEATURES		SPECIFICATIONS
Chipset	Intel® QM77	<p>Mobile Intel® QM77 Express Chipset:</p> <ul style="list-style-type: none"> • Two x4 or eight x1 PCI Express 2.0 ports operating at 5 GT/s (only one x4 PCI Express port is used on the CP6004-SA) • SATA host controller with six ports and RAID 0/1/5/10 support <ul style="list-style-type: none"> • Two SATA 6 Gb/s ports accessible via onboard connectors • Four SATA 3 Gb/s ports accessible via rear I/O • USB 2.0 host interface with up to 14 USB ports available (only six ports are used on the CP6004-SA) • USB 3.0 host interface with up to 4 USB ports available (not used on the CP6004-SA) • Integrated Ethernet controller • SPI flash interface support • Low Pin Count (LPC) interface • Power management logic support • Enhanced DMA controller, interrupt controller, and timer functions • System Management Bus (SMBus) compatible with most I²C™ devices • DMI 2.0 with 5 GT/s and FDI interfaces to the processor • High Definition Audio (HDA) interface • Analog display port • Three digital display ports • Integrated RTC
Integrated Controller	Graphics controller	<p>High-performance 3D graphics controller integrated in the processor:</p> <ul style="list-style-type: none"> • Supports analog displays (CRT) up to a resolution of 2048 x 1536 pixels with 32-bit color @ 75 Hz • Supports digital displays (HDMI/DVI) up to a resolution of 1920 x 1200 pixels @ 60 Hz • Dynamic Video Memory Technology (DVMT)
Interfaces	CompactPCI	<p>Compliant with CompactPCI Specification PICMG 2.0 R 3.0:</p> <ul style="list-style-type: none"> • System controller operation • 64-bit/66 MHz PCI or PCI-X master interface with dedicated PCIe-to-PCI-X bridge • 3.3V or 5V signaling levels (universal signaling support) <p>Compliant with the Packet Switching Specification PICMG 2.16.</p> <p>The CP6004-SA supports System Master hot swap functionality and application-dependent hot swap functionality when used in a peripheral slot.</p> <p>When used as a System Master, the CP6004-SA supports individual clocks for each slot and the ENUM signal handling is in compliance with the PICMG 2.1 Hot Swap Specification.</p> <p>When installed in a peripheral slot, the CP6004-SA is isolated from the CompactPCI bus. It receives power from the backplane and supports rear I/O and, if the system supports it, packet switching (in this case up to two channels of Gigabit Ethernet).</p>

Table 1-1: CP6004-SA Main Specifications (Continued)

FEATURES		SPECIFICATIONS
Interfaces	Rear I/O	<p>The following interfaces are routed to the rear I/O connectors J3 and J5.</p> <ul style="list-style-type: none"> • COMA (RS-232 signaling) and COMB (RS-232 signaling); no buffer on the rear I/O module is necessary • 4 x USB 2.0 • 1 x CRT VGA, 2 x HDMI/DVI • 1 x HDA • 2 x Gigabit Ethernet (compliant with PICMG 2.16, R 1.0) • 4 x SATA 3 Gb/s • 4 x GPIs and 4 GPOs (LVTTTL signaling) • System write protection <p>The rear I/O connector J4 is optionally available and provides rear I/O inter-connection to the PMC/XMC interface.</p>
	Gigabit Ethernet	<p>Five 10 Base-T/100 Base-TX/1000 Base-T Gigabit Ethernet interfaces based on one Intel® 82579LM Gigabit Ethernet controller and one Intel® I350 quad-port Gigabit Ethernet controller:</p> <ul style="list-style-type: none"> • Three RJ-45 connectors on the front panel • Two ports on the rear I/O (PICMG 2.16) • Automatic mode recognition (Auto-Negotiation) • Automatic cabling configuration recognition (Auto-MDI/X)
	USB	<p>Six USB ports supporting UHCI (USB 1.1) and EHCI (USB 2.0):</p> <ul style="list-style-type: none"> • Two type A USB 2.0 connectors on the front panel • Four USB 2.0 ports on the rear I/O interface
	Serial	<p>Two 16C550-compatible UARTs:</p> <ul style="list-style-type: none"> • One RS-232 port on the front panel and routed to rear I/O, COMA • One RS-232 port on the rear I/O, COMB
	PMC	<p>PMC interface:</p> <ul style="list-style-type: none"> • Four onboard mezzanine connectors for connecting a standard PMC module • Up to 64-bit/66 MHz PCI or up to 64-bit/133 MHz PCI-X interface with dedicated PCIe-to-PCI-X bridge • Only 3.3V PCI signaling voltage • Rear I/O supported through the CompactPCI connector J4 (optional) • Supported voltages: 3.3 V, 5 V, +12 V, and -12 V
	XMC	<p>XMC interface:</p> <ul style="list-style-type: none"> • One onboard XMC connector for connecting a standard XMC module • Up to x8 lanes PCI Express 2.0 ports operating at 5 GT/s • Rear I/O supported through the PMC connector (Jn4) to the CompactPCI connector J4 (optional)
	SATA	<p>Two SATA 6 Gb/s interfaces for:</p> <ul style="list-style-type: none"> • Up to 64 GB flash memory via an onboard SATA Flash module, or • Onboard 2.5" HDD/SSD is supported in combination with the MMADP-SATA01 module • One standard SATA 6 Gb/s interface for the standard SATA connector <p>Four SATA 3 Gb/s ports accessible via rear I/O</p>



Table 1-1: CP6004-SA Main Specifications (Continued)

FEATURES		SPECIFICATIONS
Sockets	Front Panel Connectors	<ul style="list-style-type: none"> VGA: 15-pin, D-Sub connector, J9 USB: two 4-pin, type A connectors, J6 and J7 Ethernet: three 8-pin, RJ-45 connectors, J10, J11 and J12 Serial port: one 8-pin, RJ-45 connector, J8 (COMA) PMC/XMC front panel bezel cutout
	Onboard Connectors	<ul style="list-style-type: none"> PMC connectors J21 - J24 (Jn1 - Jn4) XMC connector, J20 (P15) Two SATA connectors <ul style="list-style-type: none"> One 7-pin, standard SATA connector, J14 One 34-pin, SATA extension connector, J17 JTAG connector, J16 Debug connector, J15 XDP-SFF (debug) connector, J25 CompactPCI Connectors J1 - J5 (J4 optional) Two 204-pin DDR3 SODIMM sockets, J18 and J19
Switches	DIP Switches	Three onboard DIP switches, SW1, SW2, and SW3, for board configuration
	Reset Switch	One front panel hardware reset switch
	Hot Swap Switch	One switch for hot swap purposes integrated in the front panel handle in accordance with PICMG 2.1 Rev. 2.0.
LEDs	System LEDs	System Status LEDs: <ul style="list-style-type: none"> I0/I1 (red/green): Indicate the software status of the IPMI controller WD (green): Watchdog Status TH (red/green): Temperature Status HS (blue): Hot Swap Control General Purpose LEDs: <ul style="list-style-type: none"> LED 0..3 (red/green/amber): General Purpose/POST code
	Ethernet LEDs	Gigabit Ethernet Status on CP6004-SA: <ul style="list-style-type: none"> ACT (green): Ethernet Link/Activity SPEED (green/orange/off): Ethernet Speed
Timer	Watchdog Timer	<ul style="list-style-type: none"> Software-configurable, two-stage Watchdog with programmable timeout ranging from 125 ms to 4096 s in 16 steps Serves for generating IRQ or hardware reset
	System Timer	<ul style="list-style-type: none"> The Intel® QM77 Chipset contains three 8254-style counters which have fixed uses In addition to the three 8254-style counters, the Intel® QM77 Chipset includes eight individual high-precision event timers that may be used by the operating system. They are implemented as a single counter each with its own comparator and value register.

Table 1-1: CP6004-SA Main Specifications (Continued)

FEATURES		SPECIFICATIONS
IPMI	IPMI Controller	<ul style="list-style-type: none"> • NXP® ARM7 microcontroller with redundant 512 kB firmware flash and automatic roll-back strategy • The IPMI controller carries out IPMI commands such as monitoring several onboard temperature conditions, board voltages and the power supply status, and managing hot swap operations. • The IPMI controller is accessible via two IPMBs (through the J1 and J2 connectors) and one host Keyboard Controller Style (KCS) Interface.
Thermal	Thermal Management	<p>CPU and board overtemperature protection is provided by:</p> <ul style="list-style-type: none"> • Temperature sensors integrated in the 3rd generation Intel® Core™ i7/i5 processor: <ul style="list-style-type: none"> • One temperature sensor for monitoring each processor core • One temperature sensor for monitoring the graphics core • One temperature sensor for monitoring the package die temperature • One temperature sensor integrated in the Intel® QM77 Chipset for monitoring the chipset • One onboard temperature sensor for monitoring the board temperature • Specially designed heat sink
Security	TPM	Trusted Platform Module (TPM) 1.2 for enhanced hardware- and software-based data and system security (on request)
Software	uEFI BIOS	<p>AMI Aptio®, AMI's next-generation BIOS firmware based on the uEFI Specification and the Intel Platform Innovation Framework for EFI.</p> <ul style="list-style-type: none"> • LAN boot capability for diskless systems (standard PXE) • Redundant image; automatic fail-safe recovery in case of a damaged image • Non-volatile storage of setting in the SPI boot flash (battery only required for the RTC) • Compatibility Support Module (CSM) providing legacy BIOS compatibility based on AMIBIOS8 • Command shell for diagnostics and configuration • uEFI shell commands executable from mass storage device in a Pre-OS environment (open interface) • IPMI support in the command shell
	Software IPMI	<p>IPMI firmware providing the following features:</p> <ul style="list-style-type: none"> • The IPMI controller is accessible via up to two IPMBs, IOL and one KCS interface with interrupt support • The IPMI firmware can be updated in the field through all supported onboard interfaces using the update functions of the open-source tool "ipmitool". For further information on the ipmitool refer to the sourceforge.net web site. • Two IPMI controller flash banks with automatic roll-back capability in case of an upgrade firmware failure • Board supervision and control extensions such as board reset, power and SPI boot flash control, etc.
	Operating Systems	The board is offered with various Board Support Packages including Windows, VxWorks and Linux operating systems. For further information concerning the operating systems available for the CP6004-SA, please contact Kontron.

Table 1-1: CP6004-SA Main Specifications (Continued)

FEATURES		SPECIFICATIONS
General	Mechanical	6U, 4HP, CompactPCI-compliant form factor
	Power Consumption	See Chapter 5 for details.
	Temperature Ranges	Operational: 0°C to +60°C Standard -40°C to +70°C Extended Storage: -40°C to +85°C Without hard disk and without battery  <p><i>Note ...</i> When a battery is installed, refer to the operational specifications of the battery as this determines the storage temperature of the CP6004-SA (See "Battery" below).</p>  <p><i>Note ...</i> When additional components are installed, refer to their operational specifications as this will influence the operational and storage temperature of the CP6004-SA.</p>
	Battery	3.0V lithium battery for RTC with battery socket. Battery type: UL-approved CR2025 Temperature ranges: Operational: -20°C to +70°C typical (refer to the battery manufacturer's specifications for exact range) Storage: -55°C to +70°C typical (no discharge)
	Climatic Humidity	93% RH at 40 °C, non-condensing (acc. to IEC 60068-2-78)
	Dimensions	233.35 mm x 160 mm
	Board Weight	792 g (without mezzanine cards)

1.6 Standards

The board complies with the requirements of the following standards:

Table 1-2: Standards

TYPE	ASPECT	STANDARD	REMARKS
CE	Emission	EN55022 EN61000-6-3	--
	Immission	EN55024 EN61000-6-2	--
	Electrical Safety	EN60950-1	--
Mechanical	Mechanical Dimensions	IEEE1101.10	--
Environmental	Climatic Humidity	IEC60068-2-78	93% RH at 40°C, non-condensing (see note below)
	WEEE	Directive 2002/96/EC	Waste electrical and electronic equipment
	RoHS 2	Directive 2011/65/EU	Restriction of the use of certain hazardous substances in electrical and electronic equipment
	Vibration (Sinusoidal)	IEC60068-2-6	Ruggedized version test parameters: <ul style="list-style-type: none"> • 10-300 (Hz) frequency range • 2 (g) acceleration • 1 (oct/min) sweep rate • 10 cycles/axis • 3 axes
	Single Shock	IEC60068-2-27	Ruggedized version test parameters: <ul style="list-style-type: none"> • 30 (g) acceleration • 9 (ms) shock duration half sine • 3 number of shocks per direction (total: 18) • 6 directions • 5 (s) recovery time
	Permanent Shock	IEC60068-2-29	Ruggedized version test parameters: <ul style="list-style-type: none"> • 15 (g) acceleration • 11 (ms) shock duration half sine • 500 number of shocks per direction • 6 directions • 5 (s) recovery time

**Note ...**

Kontron performs comprehensive environmental testing of its products in accordance with applicable standards.

Customers desiring to perform further environmental testing of Kontron products must contact Kontron for assistance prior to performing any such testing. This is necessary, as it is possible that environmental testing can be destructive when not performed in accordance with the applicable specifications.

In particular, for example, boards **without conformal coating** must not be exposed to a change of temperature exceeding 1K/minute, averaged over a period of not more than five minutes. Otherwise, condensation may cause irreversible damage, especially when the board is powered up again.

Kontron does not accept any responsibility for damage to products resulting from destructive environmental testing.

1.7 Related Publications

The following publications contain information relating to this product.

Table 1-3: Related Publications

PRODUCT	PUBLICATION
CompactPCI Systems and Boards	CompactPCI Specification PICMG 2.0, Rev. 3.0 CompactPCI Packet Switching Backplane Specification PICMG 2.16 Rev. 1.0 CompactPCI System Management Specification PICMG 2.9 Rev. 1.0 CompactPCI Hot Swap Specification PICMG 2.1 Rev. 2.0
	IPMI - Intelligent Platform Management Interface Specification v2.0
	Kontron CompactPCI Backplane Manual, ID 24229
SATA	Serial ATA 1.0a Specification
PMC Module	IEEE 1386-2001, IEEE Standard for a Common Mezzanine Card (CMC) Family IEEE 1386.1-2001, IEEE Standard Physical and Environmental Layers for PCI Mezzanine Cards (PMC)
XMC Module	ANSI/VITA 42.0-200x XMC Switched Mezzanine Card Auxiliary Standard ANSI/VITA 42.3-2006 XMC PCI Express Protocol Layer Standard
Platform Firmware	Unified Extensible Firmware Interface (UEFI) Specification, Version 2.1
All Kontron products	Product Safety and Implementation Guide, ID 1021-9142
Kontron	CP6004-SA uEFI BIOS User Guide
	CP6004-SA IPMI Firmware User Guide



This page has been intentionally left blank.





Chapter **2**

Functional Description



This page has been intentionally left blank.





2. Functional Description

2.1 Processor

The CP6004-SA supports the 3rd generation Intel® Core™ i7-3615QE quad-core processor with 2.3 GHz, the 3rd generation Intel® Core™ i7-3612QE quad-core processor with 2.1 GHz, the 3rd generation Intel® Core™ i7-3555LE dual-core processor with 2.5 GHz, and the 3rd generation Intel® Core™ i5-3610ME dual-core processor with 2.7 GHz.

The 3rd generation Intel® Core™ i7/i5 processors used on the CP6004-SA include an integrated high-performance graphics controller and a DDR3 dual-channel memory controller with ECC support as well as one x8 and two x4 PCI Express 2.0 ports operating at 5 GT/s. They support various technologies, such as:

- Intel® Hyper-Threading Technology
- Intel® Turbo Boost Technology 2.0
- Intel® Intelligent Power Sharing (Intel® IPS)
- Intel® Enhanced SpeedStep® Technology
- Intel® Virtualization Technology (Intel® VT-x)
- Intel® Virtualization Technology for Directed I/O (Intel® VT-d)
- Intel® Trusted Execution Technology (Intel® TXT)
- Intel® Advanced Vector Extensions (Intel® AVX)
- Intel® Streaming SIMD Extensions 4.1 (Intel® SSE4.1)
- Intel® Streaming SIMD Extensions 4.2 (Intel® SSE4.2)
- Intel® 64 Architecture
- Execute Disable Bit

The Intel® Turbo Boost Technology and the Intel® Intelligent Power Sharing technology allow the processor and the graphics controller to opportunistically and automatically run faster than its rated operating clock frequency if it is operating below power, temperature, and current limits.

The Intel® Enhanced SpeedStep® technology enables real-time dynamic switching of the voltage and frequency between several modes. This is achieved by switching the bus ratios, the core operating voltage, and the core processor speeds without resetting the system.

The Intel® Advanced Vector Extensions (AVX) is a 256-bit instruction set extension to SSE designed for applications that are Floating Point (FP) intensive. Intel® AVX accelerates compute performance for signal and image processing applications.

The 3rd generation Intel® Core™ i7/i5 processors used on the CP6004-SA have the following multi-level cache structure:

- 64 kB L1 cache for each core
 - 32 kB instruction cache
 - 32 kB data cache
- 256 kB L2 instruction/data cache for each core
- Up to 6 MB L3 shared instruction/data cache shared between both cores



Table 2-1: Features of the Processors Supported on the CP6004-SA

FEATURE	Core™ i7-3615QE (SV) 2.3 GHz	Core™ i7-3612QE (SV) 2.1 GHz	Core™ i7-3555LE (LV) 2.5 GHz	Core™ i5-3610ME (SV) 2.7 GHz
Processor Cores	four	four	two	two
Processor Base Frequency	2.3 GHz	2.1 GHz	2.5 GHz	2.7 GHz
Maximum Turbo Frequency	3.3 GHz	3.3 GHz	3.2 GHz	3.3 GHz
L1 cache per core	64 kB	64 kB	64 kB	64 kB
L2 cache per core	256 kB	256 kB	256 kB	256 kB
L3 cache	6 MB	6 MB	4 MB	3 MB
DDR3 Memory	up to 16 GB / 1600 MHz	up to 16 GB / 1600 MHz	up to 16 GB / 1600 MHz	up to 16 GB / 1600 MHz
Graphics Base Frequency	650 MHz	650 MHz	550 MHz	650 MHz
Graphics Max. Dynamic Frequency	1.2 GHz	1.0 GHz	950 MHz	950 MHz
Thermal Design Power	45 W	35 W	25 W	35 W

2.2 Memory

The CP6004-SA supports a dual-channel (144-bit) DDR3 memory with Error Checking and Correction (ECC) running at 1600 MHz (memory error detection and reporting of 1-bit and 2-bit errors and correction of 1-bit failures). It provides two 204-pin sockets for two DDR3 ECC SO-DIMM modules that support system memory configurations of 4 GB, 8 GB or 16 GB.

However, when the internal graphics controller is enabled, the amount of memory available to applications is less than the total physical memory in the system. For example, the chipset's Dynamic Video Memory Technology dynamically allocates the proper amount of system memory required by the operating system and the application.



Note ...

Only qualified DDR3 ECC SODIMM modules from Kontron are authorized for use with the CP6004-SA. The use of SODIMM modules not released by Kontron will void the warranty.

2.3 Intel® QM77 Express Chipset

The CP6004-SA is equipped with the mobile Intel® QM77 Express Chipset, a highly integrated platform controller hub (PCH) with the following features:

- Two x4 or eight x1 PCI Express 2.0 ports operating at 5 GT/s (only one x4 PCI Express port is used on the CP6004-SA)
- SATA host controller with six ports and RAID 0/1/5/10 support
- Two SATA 6 Gb/s ports accessible via onboard connectors
- Four SATA 3 Gb/s ports accessible via rear I/O
- USB 2.0 host interface with up to 14 USB ports available (only six ports are used on the CP6004-SA)
- USB 3.0 host interface with up to 4 USB ports available (not used on the CP6004-SA)



- Integrated Ethernet controller
- SPI flash interface support
- Low Pin Count (LPC) interface
- Power management logic support
- Enhanced DMA controller, interrupt controller, and timer functions
- System Management Bus (SMBus) compatible with most I²C™ devices
- DMI 2.0 with 5 GT/s and FDI interfaces to the processor
- Intel® High Definition Audio (HDA) interface
- Analog display port
- Three digital display ports (only two ports are used on the CP6004-SA)
- Integrated RTC

2.4 Timer

The CP6004-SA is equipped with the following timers:

- Real-Time Clock
The Intel® QM77 Chipset integrates an MC146818B-compatible real-time clock with 256 byte CMOS RAM. All CMOS RAM data remain stored in an additional EEPROM device to prevent data loss.
- Counter/Timer
Three 8254-style counter/timers are included on the CP6004-SA as defined for the PC/AT.
- The Intel® QM77 Chipset integrates eight high-precision event timers.

2.5 Watchdog Timer

The CP6004-SA provides a Watchdog timer that is programmable for a timeout period ranging from 125 ms to 4096 s in 16 steps. Failure to trigger the Watchdog timer in time results in a system reset or an interrupt. In dual-stage mode, a combination of both interrupt and reset if the Watchdog is not serviced. A hardware status flag will be provided to determine if the Watchdog timer generated the reset.

2.6 Battery

The CP6004-SA is provided with a 3.0 V “coin cell” lithium battery for the RTC. For further information concerning the battery and its replacement, refer to Chapter 3.7, Battery Replacement.

2.7 Reset

The CP6004-SA is automatically reset by a precision voltage monitoring circuit that detects a drop in voltage below the acceptable operating limit or in the event of a power failure of the DC/DC converters. Other reset sources include the Watchdog timer and the push-button switch on the front panel. The CP6004-SA responds to any of these sources by initializing local peripherals.

A reset will be generated if one the following events occurs:

- Drop in voltage below the acceptable operating limit
- Power failure of at least one onboard DC/DC converter
- Push-button "RESET" pressed (on the front panel)
- Watchdog expired
- CPCI backplane PRST input
- CPCI backplane RST input (software-configurable when the board is in peripheral mode)



2.8 Flash Memory

The CP6004-SA provides flash interfaces for redundant uEFI BIOS and the SATA Flash module.

2.8.1 SPI Boot Flash for uEFI BIOS

The CP6004-SA provides two 8 MB SPI boot flashes for two separate uEFI BIOS images, a standard SPI boot flash and a recovery SPI boot flash. The fail-over mechanism for the uEFI BIOS recovery can be controlled via the IPMI controller or the DIP switch SW1. If the standard SPI boot flash is corrupted, the IPMI controller automatically enables the recovery SPI boot flash and boots the system again.

The SPI boot flash includes a hardware write protection option, which can be configured via the uEFI BIOS. If write protection is enabled, the SPI boot flash cannot be written to.



Note ...

The uEFI BIOS code and settings are stored in the SPI boot flashes. Changes made to the uEFI BIOS settings are available only in the currently selected SPI boot flash. Thus, switching over to the other SPI boot flash may result in operation with different uEFI BIOS code and settings.

2.8.2 SATA Flash Module (Optional)

The CP6004-SA supports up to 64 GB of NAND flash memory in combination with an optional SATA Flash module, which is connected to the onboard connector J17.

The SATA Flash module is an SLC-based SATA NAND flash drive with a built-in full hard-disk emulation and a high data transfer rate (sustained read rate with up to 100 MB/s and sustained write rate with up to 90 MB/s). It is optimized for embedded systems providing high performance, reliability and security.



Note ...

Write protection is available for this module. Contact Kontron for further assistance if write protection is required.

2.9 Trusted Platform Module 1.2 (On Request)

The CP6004-SA has been designed to support the Trusted Platform Module (TPM) 1.2. This feature is available on request. TPM1.2 is a security chip specifically designed to provide enhanced hardware- and software-based data and system security. It stores sensitive data such as encryption and signature keys, certificates and passwords, and is able to withstand software attacks to protect the stored information.

Hardware features of the TPM 1.2:

- TCG 1.2 compliant Trusted Platform Module (TPM)
- Security architecture based on the Atmel AT97SC3204 security controller
- EEPROM for TCG firmware enhancements and for user data and keys
- Advanced Crypto Engine (ACE) with RSA support up to 2048-bit key length
- Hardware accelerator for SHA-1 hash algorithm
- True Random Number Generator (TRNG)
- Tick counter with tamper detection
- Protection against Dictionary Attack
- Intel® Trusted Execution Technology Support
- Full personalization with Endorsement Key (EK) and EK certificate



2.10 Board Interfaces

2.10.1 Front Panel LEDs

The CP6004-SA is equipped with two IPMI LEDs (I0 and I1), one Watchdog Status LED (WD LED), one Temperature Status LED (TH LED), four General Purpose/POST code LEDs (LED 0..3), and one Hot Swap LED (HS LED). Their functionality is described in the following chapters and reflected in the registers mentioned in Chapter 4, Configuration.

2.10.1.1 IPMI and Hot Swap LEDs

The IPMI LEDs I0 and I1 show the software status of the IPMI controller. The Hot Swap LED indicates when the board may be extracted. It can be switched on or off by software and may be used, for example, to indicate that the shutdown process is finished and the board is ready for extraction.

The following table indicates the function of the IPMI LEDs and the Hot Swap LED.

Table 2-2: IPMI and Hot Swap LEDs Function

LED	COLOR	NORMAL MODE		OVERRIDE MODE
I0 (right)	red	Off	IPMI controller running	Selectable by user • Only lamp test
		On	IPMI controller out of service or in reset state	
		Blinking	IPMI controller firmware upgrade	
	green	Pulsing	Traffic on the IPMB bus	
I1 (left)	red	On	Health error detected	Selectable by user • Only lamp test
	red/amber	Blinking	Health error detected, IPMI controller running showing its heart beat	
		Pulsing	Health error detected, KCS interface active	
	green	Off	No health error detected	
		Pulsing	KCS interface active	
		Blinking	IPMI controller running showing its heart beat	
HS LED	blue	Off	Board in normal operation Do not extract the board.	Selectable by user • Only lamp test
		Blinking	Board hot swap in progress Board is not ready for extraction. Do not actuate the hot swap handle. Blinking pattern: a) Long on, short off: the IPMI controller starts the payload b) Long off, short on: the IPMI controller shuts down the payload Wait until the HS LED stops blinking and remains on to extract the board.	
	On	a) Board ready for hot swap extraction, or b) Board has just been inserted in a powered system		



2.10.1.2 Watchdog and Temperature Status LEDs

The CP6004-SA provides one Watchdog Status LED (WD LED) and one Temperature Status LED (TH LED).



Note ...

If the TH LED flashes red at regular intervals, it indicates that the processor junction temperature has reached a level beyond which permanent silicon damage may occur. Upon assertion of THERMTRIP#, the processor will shut off its internal clocks (thus halting program execution) in an attempt to reduce the processor junction temperature.

Once activated, THERMTRIP# remains latched until a cold restart of the CP6004-SA is undertaken (all power off and then on again).

Table 2-3: Watchdog and Temperature Status LEDs Function

LED	COLOR	FUNCTION DURING BOOT-UP	FUNCTION AFTER BOOT-UP
WD LED	red/ green	The WD LED is not lit during boot-up.	Watchdog Status The WD LED states are: <ul style="list-style-type: none"> • Off: Watchdog inactive • Green: Watchdog active, waiting to be triggered • Red: Watchdog expired
TH LED	red/ green	The TH LED is lit green during boot-up.	Temperature Status The TH LED states are: <ul style="list-style-type: none"> • Off: Power failure • Green: If the CPU temperature is below 105°C • Red: In case of overtemperature of the CPU, i.e. the CPU has reached a temperature above 105°C • Red blinks: If the CPU has been shut off, i.e. the CPU has reached a temperature above 125°C. In this event, all General Purpose LEDs (LED3..LED0) are blinking red as well.



2.10.1.3 General Purpose LEDs

The CP6004-SA provides four General Purpose LEDs (LED0..3) on the front panel. They are designed to indicate the boot-up POST code after which they are available to the application.

If the LED0..3 are lit red during boot-up, a failure is indicated before the uEFI BIOS has started. In this case, check the power supply. If the power supply appears to be functional and the LEDs are still red, please contact Kontron for further assistance.

The POST code is indicated during the boot-up phase. After boot-up, the LEDs indicate General Purpose or Port 80 signals, depending on the uEFI BIOS settings. The default setting after boot-up is General Purpose.

Table 2-4: General Purpose LEDs Function

LED	COLOR	FUNCTION DURING BOOT-UP	FUNCTION DURING uEFI BIOS POST (if POST code config. is enabled)	FUNCTION AFTER BOOT-UP
LED3	red	When lit up during boot-up, it indicates a power-on reset.	--	General Purpose or Port 80 <i>Default: General Purpose</i>
	green	--	uEFI BIOS POST bit 3 and bit 7	
	amber	--	--	
LED2	red	When lit, it indicates a catastrophic CPU error.	--	General Purpose or Port 80 <i>Default: General Purpose</i>
	green	--	uEFI BIOS POST bit 2 and bit 6	
	amber	--	--	
LED1	red	When lit up during boot-up, it indicates a hardware reset.	--	General Purpose or Port 80 <i>Default: General Purpose</i>
	green	--	uEFI BIOS POST bit 1 and bit 5	
	amber	--	--	
LED0	red	When lit up during boot-up, it indicates a uEFI BIOS boot failure.	--	General Purpose or Port 80 <i>Default: General Purpose</i>
	green	--	uEFI BIOS POST bit 0 and bit 4	
	amber	--	--	



Note ...

The bit allocation for Port 80 is the same as for the POST code.



For further information regarding the configuration of the General Purpose LEDs, refer to Chapter 4.4.14, LED Configuration Register, and Chapter 4.4.15, LED Control Register.

How to Read the 8-Bit POST Code

Due to the fact that only 4 bits are available and 8 bits must be displayed, the POST code output is multiplexed on the General Purpose LEDs.

Table 2-5: POST Code Sequence

STATE	GENERAL PURPOSE LEDs
0	All LEDs are OFF; start of sequence
1	High nibble
2	Low nibble

The following is an example of the General Purpose LEDs' operation if the POST configuration is enabled (see also Table 2-4, "General Purpose LED Function").

Table 2-6: POST Code Example

	LED3	LED2	LED1	LED0	RESULT
HIGH NIBBLE	off (0)	on (1)	off (0)	off (0)	0x4
LOW NIBBLE	off (0)	off (0)	off (0)	on (1)	0x1
POST CODE					0x41



Note ...

Under normal operating conditions, the General Purpose LEDs should not remain lit during boot-up. They are intended to be used for debugging purposes. In the event that a General Purpose LED lights up during boot-up and the CP6004-SA does not boot, please contact Kontron for further assistance.





2.10.2 DIP Switches SW1, SW2 and SW3

The CP6004-SA is equipped with one 4-bit DIP switch, SW1, and two 2-bit DIP switches, SW2 and SW3, which enable the board to be configured according to the application requirements. DIP Switch SW1 is used for uEFI BIOS boot configuration. DIP Switch SW2 is used for configuring the CompactPCI interface. DIP Switch SW3 is used for configuring the PMC interface.

Table 2-7: DIP Switch SW1 Function

SWITCH	FUNCTION
1	POST Code indication
2	SPI boot flash selection
3	Reserved
4	Clear uEFI BIOS settings

Table 2-8: DIP Switch SW2 Function

SWITCH	FUNCTION
1	PCI frequency of the CompactPCI interface
2	PCI/PCI-X mode of the CompactPCI interface

Table 2-9: DIP Switch SW3 Function

SWITCH	FUNCTION
1	PCI/PCI-X frequency multiplier configuration
2	PCI/PCI-X mode of the PMC interface

For further information on the configuration of the DIP switches, refer to Chapter 4.1, “DIP Switches SW1, SW2 and SW3 Configuration”.



2.10.3 USB Interfaces

The CP6004-SA supports six USB 2.0 ports: two on the front I/O, and four on the rear I/O. On the four rear I/O ports it is strongly recommended to use a cable below 3 metres in length for USB 2.0 devices. All six ports are high-speed, full-speed, and low-speed capable.

One USB peripheral may be connected to each port. For connecting more USB devices to the CP6004-SA than there are available ports, an external USB hub is required.



Note ...

The USB host interfaces can be used with maximum 500 mA continuous load current as specified in the Universal Serial Bus Specification, Revision 2.0. Short-circuit protection is provided. All the signal lines are EMI-filtered.

2.10.3.1 USB Connectors J6 and J7

The CP6004-SA has two USB 2.0 interfaces that are implemented as two 4-pin, type A USB connectors on the front panel, J6 and J7, with the following pinout:

Figure 2-1: USB Con. J6 and J7

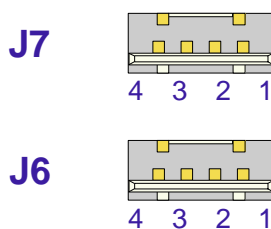

Table 2-10: USB Con. J6 and J7 Pinout

PIN	SIGNAL	FUNCTION	I/O
1	VCC	VCC	--
2	UV0-	Differential USB-	I/O
3	UV0+	Differential USB+	I/O
4	GND	GND	--

2.10.4 Integrated Graphics Controller

The 3rd gen. Intel® Core™ i7/i5 processor includes a highly integrated graphics accelerator delivering high-performance 3D, 2D graphics capabilities with the following features:

- Intel® Dynamic Video Memory Technology
- Intel® Smart 2D Display Technology
- DirectX Video Acceleration (DXVA) support for accelerating video processing (Full AVC/VC1/MPEG2 HW Decode)
- DirectX11, DirectX10.1, DirectX10 and DirectX9 support
- OpenGL 3.0 support
- 2 x HDMI/DVI display interface with 1920 x 1200 pixels @ 60 Hz
- 1 x CRT display interface with 2048 x 1536 pixels with 32-bit color @ 75 Hz

2.10.4.1 Graphics Memory Usage

The 3rd gen. Intel® Core™ i7/i5 processor supports Dynamic Video Memory Technology (Intel® DVMT) with up to 512 MB memory. This technology ensures the most efficient use of all available memory for maximum 3D graphics performance. DVMT dynamically responds to application requirements allocating display and texturing memory resources as required.





2.10.4.2 Analog VGA Connector

On the front panel, the CP6004-SA provides one 15-pin female connector, J9, used to connect an analog VGA monitor.

Figure 2-2: D-Sub VGA Con. J9 Table 2-11: D-Sub VGA Connector J9 Pinout

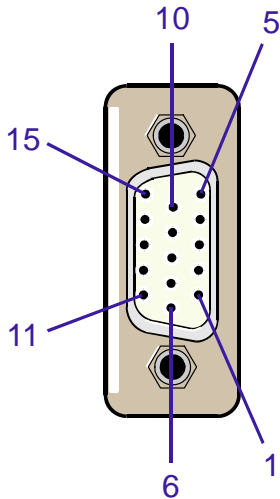

PIN	SIGNAL	FUNCTION	I/O
1	Red	Red video signal output	O
2	Green	Green video signal output	O
3	Blue	Blue video signal output	O
10	VGA_DETECT	Monitor detection signal	I
13	Hsync	Horizontal sync.	TTL Out
14	Vsync	Vertical sync.	TTL Out
12	Sdata	I ² C data (EDID)	I/O
15	Sclk	I ² C clock (EDID)	I/O
9	VCC	Power +5V, 1.5 A fuse protection	O
5,6,7,8	GND	Ground signal	--
4,11	NC	--	--

* Pin 10 is normally defined as Ground but is used on the CP6004-SA as detection signal of a connected monitor if the uEFI BIOS setting for the CP6004-SA is "AUTO" (the uEFI BIOS default setting is "FRONT").



Note ...

If the automatic VGA detection mechanism on the CP6004-SA is used, the user must ensure that the VGA cable and the connected monitor have a Ground signal on pin 10. Otherwise the interface is not operable.



Note ...

The VGA interface can be used both on the front panel and on the rear I/O. However, the VGA signals are switched to front I/O or rear I/O, depending on the uEFI BIOS setting.



2.10.5 COM Ports

The CP6004-SA provides two COM ports, COMA and COMB. COMA is available on the front panel as a serial RS-232, 8-pin, RJ-45 connector, J8, and on the rear I/O simultaneously. COMB is only available as an RS-232 interface on the rear I/O. If RS-422 is required on the COMB port, please contact Kontron for further assistance.

COMA and COMB are fully compatible with the 16550 controller. The rear I/O COMA port includes a complete set of handshaking and modem control signals. The COMB port includes RXD, TXD, CTS, and RTS signals.

The COMA and COMB ports provide maskable interrupt generation. The data transfer on the COM ports is up to 115.2 kbit/s.

The following figure and table provide pinout information for the serial connector J8 (COMA).

Figure 2-3: Serial Con. J8 (COMA)

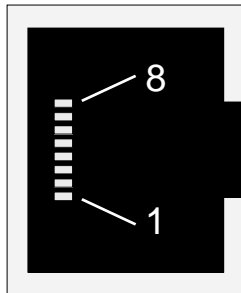

Table 2-12: Serial Con. J8 (COMA) Pinout

PIN	SIGNAL	FUNCTION	I/O
1	RTS	Request to send	O
2	DTR	Data terminal ready	O
3	TXD	Transmit data	O
4	GND	Signal ground	--
5	GND	Signal ground	--
6	RXD	Receive data	I
7	DSR	Data set ready	I
8	CTS	Clear to send	I



Note ...

COMA can be used either on the front panel or on the rear I/O. It is not possible to use COMA on the front panel and the rear I/O simultaneously.





2.10.6 Gigabit Ethernet

The CP6004-SA board provides five 10Base-T/100Base-TX/1000Base-T Ethernet interfaces. They are based on one Intel® I350 quad-port Gigabit Ethernet controller and one Intel® 82579LM Gigabit Ethernet controller.

The Intel® I350 quad-port Gigabit Ethernet controller provides four Gigabit Ethernet interfaces, two on the front panel, GbE A and GbE B, and two on the rear I/O, PICMG 2.16 LPa and PICMG 2.16 LPb. The Intel® 82579LM Gigabit Ethernet controller provides one Gigabit Ethernet interface on the front panel, GbE E.

The Boot from LAN feature is supported.

The Ethernet connectors J10, J11 and J12 are realized as RJ-45 connectors. The interfaces provide automatic detection and switching between 10Base-T, 100Base-TX and 1000Base-T data transmission (Auto-Negotiation). Auto-wire switching for crossed cables is also supported (Auto MDI-X).

The following table indicates the Gigabit Ethernet port mapping of the CP6004-SA.

Table 2-13: Gigabit Ethernet Port Mapping

ETHERNET CONTROLLER	PORT MAPPING
Intel® I350, port 0	Rear I/O port PICMG 2.16 LPb
Intel® I350, port 1	Rear I/O port PICMG 2.16 LPa
Intel® I350, port 2	Front I/O connector J11 (GbE B)
Intel® I350, port 3	Front I/O connector J10 (GbE A)
Intel® 82579LM	Front I/O connector J12 (GbE E)

Figure 2-4: GbE Con. J10, J11 and J12

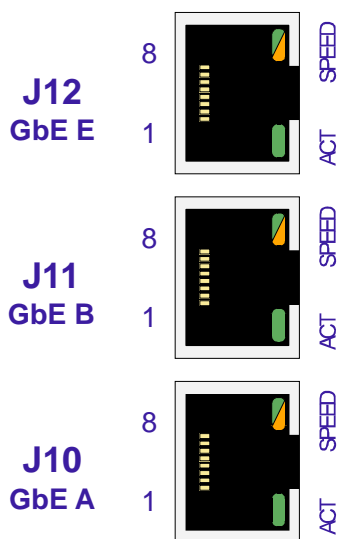

Table 2-14: Pinout of GbE Con. J10, J11 and J12

PIN	MDI / STANDARD ETHERNET CABLE					
	10BASE-T		100BASE-TX		1000BASE-T	
	I/O	SIGNAL	I/O	SIGNAL	I/O	SIGNAL
1	0	TX+	0	TX+	I/O	BI_DA+
2	0	TX-	0	TX-	I/O	BI_DA-
3	1	RX+	1	RX+	I/O	BI_DB+
4	-	-	-	-	I/O	BI_DC+
5	-	-	-	-	I/O	BI_DC-
6	1	RX-	1	RX-	I/O	BI_DB-
7	-	-	-	-	I/O	BI_DD+
8	-	-	-	-	I/O	BI_DD-



Ethernet LED Status

ACT (green): This LED monitors network connection and activity. When this LED is lit, it means that a link has been established. The LED blinks when network packets are sent or received through the RJ-45 port. When this LED is not lit, there is no link established.

SPEED (green/orange/off): This LED lights up to indicate a successful 100Base-TX or 1000Base-T connection. When green it indicates a 100Base-TX connection and when orange it indicates a 1000Base-TX connection. When not lit and the ACT LED is active, the connection is operating at 10Base-T.

2.10.7 SATA Interface

The CP6004-SA provides six SATA interfaces with RAID support, two interfaces are implemented as onboard SATA connectors and four SATA interfaces are available only on the rear I/O.

The onboard SATA interfaces support up to 6 Gb/s SATA. One of the onboard SATA connectors, J17, supports the mounting of either a SATA Flash module or an onboard 2.5" HDD/SSD via the MMADP-SATA01 module. The other SATA connector, J14, is used for standard SATA devices with cable connection.

All six SATA ports provide high-performance RAID 0/1/5/10 functionality.

2.10.7.1 SATA Connector J14

The CP6004-SA provides a standard SATA connector, J14, for connecting SATA devices to the CP6004-SA.

Figure 2-5: SATA Con. J14

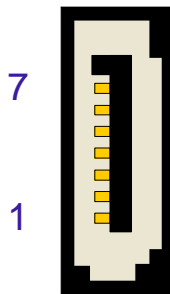

Table 2-15: SATA Connector J14 Pinout

PIN	SIGNAL	FUNCTION	I/O
1	GND	Ground signal	--
2	SATA_TX+	Differential Transmit +	O
3	SATA_TX-	Differential Transmit -	O
4	GND	Ground signal	--
5	SATA_RX-	Differential Receive -	I
6	SATA_RX+	Differential Receive +	I
7	GND	Ground signal	--



Note ...

If the onboard SATA connector, J14, will be used, due to the big SATA connector and the stiff SATA cable, the CP6004-SA will exceed the thickness of 4HP.





2.10.8 PMC Interface

The CP6004-SA provides a PMC interface with a dedicated PCI Express-to-PCI-X bridge from Pericom (PI7C9X130). This interface is configurable for either 64-bit/66 MHz PCI or 64-bit/133 MHz PCI-X operation and is compliant with the IEEE 1386.1-2001 specification, which defines a PCI electrical interface for the CMC (Common Mezzanine Card) form factor. The board provides only 3.3V PMC PCI/PCI-X signaling environment.

A PMC module can be connected to the CP6004-SA via the J21 (Jn3), J22 (Jn1), J23 (Jn4) and J24 (Jn2). The J22 (Jn1) and J24 (Jn2) connectors provide the signals for the 32-bit PCI bus. The 64-bit extension for the PMC interface is supported by the J21 (Jn3) connector. User-defined I/O signals are supported on the J23 (Jn4) connector and are connected to the CompactPCI rear I/O connector J4.

The PCI Express-to-PCI-X bridge detects the PCI mode (PCI or PCI-X) and the bus speed (33 MHz, 66 MHz, 100 MHz or 133 MHz) via two PCI control signals: PCIXCAP on J22 (pin 39) and M66EN on J24 (pin 47). The following configurations are supported by the PMC interface.

Table 2-16: PMC PCI/PCI-X Configuration

FREQUENCY	MODE	M66EN J24 (Jn2), PIN 47	PCIXCAP J22 (Jn1), PIN 39	DIP SWITCH SW3 SWITCH 1
33 MHz	PCI	Low	Low	OFF
66 MHz	PCI	High	Low	OFF
66 MHz	PCI-X	--	Pull-down resistor	OFF
100 MHz	PCI-X	--	High	ON
133 MHz	PCI-X	--	High	OFF

The default configuration of the DIP switch SW3, switch 1, is OFF. If this switch is set to OFF, the PCI/PCI-X interface frequency is 33 MHz, 66 MHz or 133 MHz.



Warning!

DIP switch SW3, switch 1, must be set in accordance with Table 2-16.

Failure to comply with the above will cause unexpected system error due to non-compliance of the PMC subsystem with the PCI-X specification.



Figure 2-6: PMC Connectors J21, J22, J23 and J24

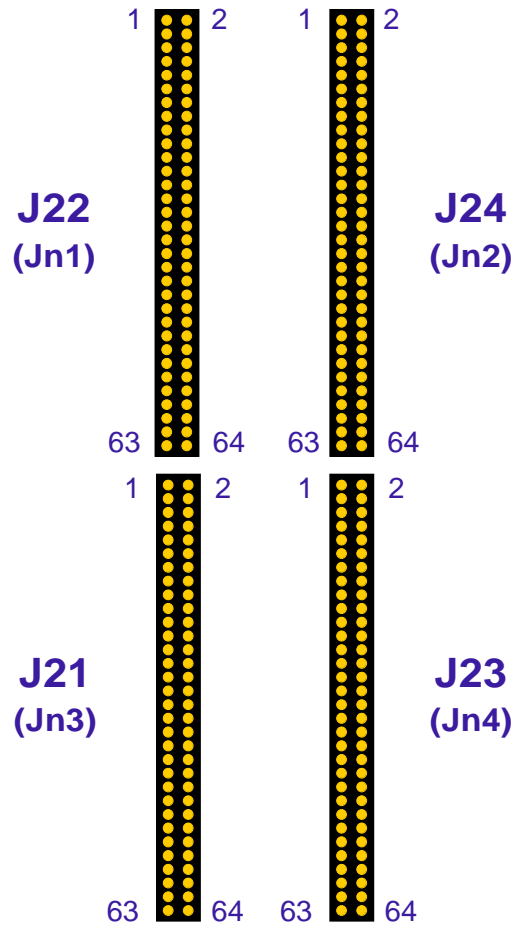

2.10.8.1 PMC Connectors J21, J22, J23 and J24 Pinout

Table 2-17: PMC Connectors J22 and J24 Pinout

J22 (Jn1)				J24 (Jn2)			
SIGNAL	PIN	PIN	SIGNAL	SIGNAL	PIN	PIN	SIGNAL
TCK (pull-up)	1	2	-12V	+12V	1	2	TRST# (pull-down)
Ground	3	4	INTA#	TMS (pull-up)	3	4	TDO (NC)
INTB#	5	6	INTC#	TDI (pull-up)	5	6	Ground
BUSMODE1# (NC)	7	8	+5V	Ground	7	8	PCI-RSV (NC)
INTD#	9	10	PCI-RSV (NC)	PCI-RSV (NC)	9	10	PCI-RSV (NC)
Ground	11	12	3V3-AUX (NC)	BUSMODE2# (pull-up)	11	12	+3.3V
CLK	13	14	Ground	RST#	13	14	BUSMODE3# (GND)
Ground	15	16	GNT#	+3.3V	15	16	BUSMODE4# (GND)
REQ#	17	18	+5V	RSV	17	18	Ground
V (I/O)	19	20	AD[31]	AD[30]	19	20	AD[29]
AD[28]	21	22	AD[27]	Ground	21	22	AD[26]
AD[25]	23	24	Ground	AD[24]	23	24	+3.3V
Ground	25	26	C/BE[3]	IDSEL	25	26	AD[23]
AD[22]	27	28	AD[21]	+3.3V	27	28	AD[20]
AD[19]	29	30	+5V	AD[18]	29	30	Ground
V (I/O)	31	32	AD[17]	AD[16]	31	32	C/BE[2]#
FRAME#	33	34	Ground	Ground	33	34	PMC-RSV (NC)
Ground	35	36	IRDY#	TRDY#	35	36	+3.3V
DEVSEL#	37	38	+5V	Ground	37	38	STOP#
PCIXCAP	39	40	LOCK#	PERR#	39	40	Ground
PCI-RSV (NC)	41	42	PCI-RSV (NC)	+3.3V	41	42	SERR#
PAR	43	44	Ground	C/BE[1]#	43	44	Ground
V (I/O)	45	46	AD[15]	AD[14]	45	46	AD[13]
AD[12]	47	48	AD[11]	M66EN	47	48	AD[10]
AD[09]	49	50	+5V	AD[08]	49	50	+3.3V
Ground	51	52	C/BE[0]#	AD[07]	51	52	PMC-RSV (NC)
AD[06]	53	54	AD[05]	+3.3V	53	54	PMC-RSV (NC)
AD[04]	55	56	Ground	PMC-RSV (NC)	55	56	Ground
V (I/O)	57	58	AD[03]	PMC-RSV (NC)	57	58	PMC-RSV (NC)
AD[02]	59	60	AD[01]	Ground	59	60	PMC-RSV (NC)
AD[00]	61	62	+5V	ACK64#	61	62	+3.3V
Ground	63	64	REQ64#	Ground	63	64	PMC-RSV (NC)



Table 2-18: PMC Connectors J21 and J23 Pinout

J21 (Jn3)				J23 (Jn4)			
SIGNAL	PIN	PIN	SIGNAL	SIGNAL	PIN	PIN	SIGNAL
PCI-RSV (NC)	1	2	Ground	Rear I/O	1	2	Rear I/O
Ground	3	4	C/BE[7]	Rear I/O	3	4	Rear I/O
C/BE[6]	5	6	C/BE[5]	Rear I/O	5	6	Rear I/O
C/BE[4]	7	8	Ground	Rear I/O	7	8	Rear I/O
V(I/O)	9	10	PAR64	Rear I/O	9	10	Rear I/O
AD[63]	11	12	AD[62]	Rear I/O	11	12	Rear I/O
AD[61]	13	14	Ground	Rear I/O	13	14	Rear I/O
Ground	15	16	AD[60]	Rear I/O	15	16	Rear I/O
AD[59]	17	18	AD[58]	Rear I/O	17	18	Rear I/O
AD[57]	19	20	Ground	Rear I/O	19	20	Rear I/O
V(I/O)	21	22	AD[56]	Rear I/O	21	22	Rear I/O
AD[55]	23	24	AD[54]	Rear I/O	23	24	Rear I/O
AD[53]	25	26	Ground	Rear I/O	25	26	Rear I/O
Ground	27	28	AD[52]	Rear I/O	27	28	Rear I/O
AD[51]	29	30	AD[50]	Rear I/O	29	30	Rear I/O
AD[49]	31	32	Ground	Rear I/O	31	32	Rear I/O
Ground	33	34	AD[48]	Rear I/O	33	34	Rear I/O
AD[47]	35	36	AD[46]	Rear I/O	35	36	Rear I/O
AD[45]	37	38	Ground	Rear I/O	37	38	Rear I/O
V(I/O)	39	40	AD[44]	Rear I/O	39	40	Rear I/O
AD[43]	41	42	AD[42]	Rear I/O	41	42	Rear I/O
AD[41]	43	44	Ground	Rear I/O	43	44	Rear I/O
Ground	45	46	AD[40]	Rear I/O	45	46	Rear I/O
AD[39]	47	48	AD[38]	Rear I/O	47	48	Rear I/O
AD[37]	49	50	Ground	Rear I/O	49	50	Rear I/O
Ground	51	52	AD[36]	Rear I/O	51	52	Rear I/O
AD[35]	53	54	AD[34]	Rear I/O	53	54	Rear I/O
AD[33]	55	56	Ground	Rear I/O	55	56	Rear I/O
V(I/O)	57	58	AD[32]	Rear I/O	57	58	Rear I/O
PCI-RSV (NC)	59	60	PCI-RSV (NC)	Rear I/O	59	60	Rear I/O
PCI-RSV (NC)	61	62	Ground	Rear I/O	61	62	Rear I/O
Ground	63	64	PCI-RSV (NC)	Rear I/O	63	64	Rear I/O



Note ...

The signals from the J23 (Jn4) PMC connector are routed to the J4 CompactPCI rear I/O connector in such a way that they can only be used for low-speed signals.

2.10.9 XMC Interface

For easy and flexible configuration one onboard XMC connector, J20, is available. The board uses one x8 PCI Express 2.0 interface operating at 5.0 GT/s and compliant with the ANSI/VITA 42.0 and ANSI/VITA 42.3 specifications.

User-defined I/O signals are also supported on the PMC/XMC slot via the PMC connector J23 (Jn4) and are connected to the CompactPCI rear I/O connector J4 (optional).



Note ...

Only XMC modules with one board-to-board connector (P15) can be used with the CP6004-SA.

Figure 2-7: XMC Con. J20 Table 2-19: XMC Connector J20 Pinout

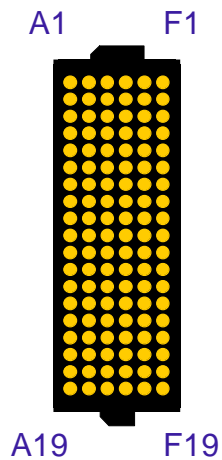

PIN	ROW A	ROW B	ROW C	ROW D	ROW E	ROW F
1	PET0p0	PET0n0	3.3V	PET0p1	PET0n1	VPWR
2	GND	GND	TRST#	GND	GND	MRSTI#
3	PET0p2	PET0n2	3.3V	PET0p3	PET0n3	VPWR
4	GND	GND	TCK	GND	GND	MRSTO#
5	PET0p4	PET0n4	3.3V	PET0p5	PET0n5	VPWR
6	GND	GND	TMS	GND	GND	+12V
7	PET0p6	PET0n6	3.3V	PET0p7	PET0n7	VPWR
8	GND	GND	TDI	GND	GND	-12V
9	RFU (NC)	RFU (NC)	RFU (NC)	RFU (NC)	RFU (NC)	VPWR
10	GND	GND	TDO	GND	GND	GA0 (high)
11	PER0p0	PER0n0	MBIST#	PER0p1	PER0n1	VPWR
12	GND	GND	GA1 (low)	GND	GND	MPRESENT#
13	PER0p2	PER0n2	3.3V AUX	PER0p3	PER0n3	VPWR
14	GND	GND	GA2 (low)	GND	GND	MSDA
15	PER0p4	PER0n4	RFU (NC)	PER0p5	PER0n5	VPWR
16	GND	GND	MVMRO (NC)	GND	GND	MSCL
17	PER0p6	PER0n6	RFU (NC)	PER0p7	PER0n7	RFU (NC)
18	GND	GND	RFU (NC)	GND	GND	RFU (NC)
19	CLK+0	CLK-0	RFU (NC)	WAKE#	ROOT0#	RFU (NC)

Legend:

RFU Reserved for future use

VPWR 5V power supply for the XMC module



2.10.10 Debug Interface

The CP6004-SA provides several onboard options for hardware and software debugging, such as:

- Four bicolor General Purpose LEDs (LED0..3), which indicate hardware failures, uEFI BIOS POST codes and user-configurable outputs
- A JTAG connector, J16, for programming the onboard logic
- An XDP-SFF, processor JTAG connector, J25, for facilitating the debug and uEFI BIOS software development

2.10.11 CompactPCI Interface

The CP6004-SA supports a flexibly configurable, hot swap CompactPCI interface. In the system slot the PCI/PCI-X interface is in the transparent mode, and in the peripheral slot the CompactPCI interface is isolated so that it cannot communicate with the CompactPCI bus. This mode is known as "passive mode".

2.10.11.1 Board Functionality when Installed in System Slot

In the system slot, the CompactPCI interface can be either a 64-bit/66 MHz PCI or PCI-X interface via a dedicated PCI Express-to-PCI-X bridge from Pericom (PI7C9X130).

The CP6004-SA supports up to seven peripheral slots with 33 MHz and up to 4 peripheral slots with 66 MHz through a backplane.

The PCI Express-to-PCI-X bridge detects the PCI mode (PCI or PCI-X) and the bus speed (33 MHz or 66 MHz) via two PCI control signals on J1: PCIXCAP (pin B16) and M66EN (pin D21). The following configurations are supported by the CompactPCI interface.

Table 2-20: CompactPCI PCI/PCI-X Configuration

FREQUENCY	MODE	M66EN J1, PIN D21	PCIXCAP J1, PIN B16	DIP SWITCH SW2 SWITCH 1	DIP SWITCH SW2 SWITCH 2
33 MHz	PCI	Low	Low	OFF	OFF
33 MHz	PCI	--	Low	OFF	ON
66 MHz	PCI	High	Low	OFF	OFF
66 MHz	PCI	High	--	ON	OFF
66 MHz	PCI-X	--	Pull-down resistor	OFF	OFF



Note ...

To support 66 MHz PCI/PCI-X frequency, the CompactPCI signaling voltage (VI/O) must be 3.3 V.

The CP6004-SA provides automatic voltage detection for the VI/O to switch the PCI frequency to 33 MHz in a 5V environment.





2.10.11.2 Board Functionality when Installed in Peripheral Slot (Passive Mode)

In a peripheral slot, the board receives power but does not communicate on the CompactPCI bus; all CompactPCI signals are isolated.

In this configuration, the communication is achieved via the two Gigabit Ethernet ports as defined in the PICMG 2.16 specification.

2.10.11.3 Packet Switching Backplane (PICMG 2.16)

The CP6004-SA supports two Gigabit Ethernet ports on the J3 connector in accordance with the CompactPCI Packet Switching Backplane Specification PICMG 2.16. The two ports are connected in the chassis via the CompactPCI Packet Switching Backplane to the Fabric slots "A" and "B".

The PICMG 2.16 feature can be used in the system slot and in the peripheral slot as well.

2.10.11.4 Hot Swap Support

To ensure that a board may be removed and replaced in a working bus without disturbing the system, the following additional features are required:

- Power ramping
- Precharge
- Hot swap control and status register bits
- Automatic interrupt generation whenever a board is about to be removed or replaced
- A Hot Swap LED to indicate that the board may be safely removed

2.10.11.5 Power Ramping

On the CP6004-SA a special hot swap controller is used to ramp up the onboard supply voltage. This is done to avoid transients on the +3.3V, +5V, +12V and -12V power supplies from the hot swap system. When the power supply is stable, the hot swap controller generates an onboard reset to put the board into a definite state.

2.10.11.6 Precharge

Precharge is provided on the CP6004-SA by a resistor on each signal line (PCI bus) connected to a +1V reference voltage.

2.10.11.7 Handle Switch

A microswitch is situated in the extractor handle. The status of the handle is included in the onboard logic. The microswitch is connected to the onboard connector J13.

2.10.11.8 ENUM# Interrupt

If the board is operated in the system slot, the ENUM signal is an input.

2.10.11.9 Hot Swap LED

The blue HS LED can be switched on or off by software. It may be used, for example, to indicate that the shutdown process is finished and the board is ready for extraction.



2.10.12 CompactPCI Bus Connector

The complete CompactPCI connector configuration comprises up to five connectors designated as J1 to J5. Their functions are as follows:

- J1/J2: 64-bit CompactPCI interface with PCI bus signals, arbitration, clock and power
- J3, J4 and J5 have rear I/O interface functionality
- J4 only has optional rear I/O functionality from the PMC module

The CP6004-SA is designed for a CompactPCI bus architecture. The CompactPCI standard is electrically identical to the PCI local bus. However, these systems are enhanced to operate in rugged industrial environments and to support multiple slots.

2.10.12.1 CompactPCI Connector Keying

The CompactPCI connectors support guide lugs to ensure a correct polarized mating.

The CP6004-SA supports universal PCI VI/O signaling voltages with one common termination resistor configuration and includes a PCI VI/O voltage detection circuit. If the PCI VI/O voltage is 5 V, the maximum supported PCI frequency is 33 MHz.

Figure 2-8: CompactPCI Con. J1-J5

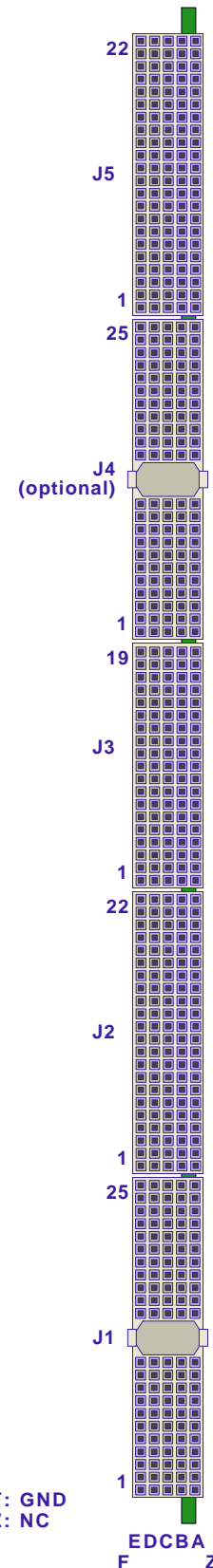

Note:
Pinrow F: GND
Pinrow Z: NC



2.10.12.2 CompactPCI Connectors J1 and J2 Pinout

The CP6004-SA is provided with two 2 mm x 2 mm pitch female CompactPCI bus connectors, J1 and J2.

Table 2-21: CompactPCI Bus Connector J1 System Slot Pinout

PIN	Z	A	B	C	D	E	F
25	NC	5V	REQ64#	ENUM#	3.3V	5V	GND
24	NC	AD[1]	5V	V(I/O)	AD[0]	ACK64#	GND
23	NC	3.3V	AD[4]	AD[3]	5V	AD[2]	GND
22	NC	AD[7]	GND	3.3V	AD[6]	AD[5]	GND
21	NC	3.3V	AD[9]	AD[8]	M66EN	C/BE[0]#	GND
20	NC	AD[12]	GND	V(I/O)	AD[11]	AD[10]	GND
19	NC	3.3V	AD[15]	AD[14]	GND	AD[13]	GND
18	NC	SERR#	GND	3.3V	PAR	C/BE[1]#	GND
17	NC	3.3V	IPMB SCL	IPMB SDA	GND	PERR#	GND
16	NC	DEVSEL#	PCIXCAP	V(I/O)	STOP#	LOCK#	GND
15	NC	3.3V	FRAME#	IRDY#	BDSEL#	TRDY#	GND
14-12	Key Area						
11	NC	AD[18]	AD[17]	AD[16]	GND	C/BE[2]#	GND
10	NC	AD[21]	GND	3.3V	AD[20]	AD[19]	GND
9	NC	C/BE[3]#	NC	AD[23]	GND	AD[22]	GND
8	NC	AD[26]	GND	V(I/O)	AD[25]	AD[24]	GND
7	NC	AD[30]	AD[29]	AD[28]	GND	AD[27]	GND
6	NC	REQ0#	CPCI_Present#	3.3V	CLK0	AD[31]	GND
5	NC	RSV	RSV	RST#	GND	GNT0#	GND
4	NC	IPMB PWR	Health#	V(I/O)	RSV	RSV	GND
3	NC	INTA#	INTB#	INTC#	5V	INTD#	GND
2	NC	TCK	5V	TMS	NC	TDI	GND
1	NC	5V	-12V	TRST#	+12V	5V	GND



Table 2-22: CompactPCI Bus Connector J1 Peripheral Slot Pinout

PIN	Z	A	B	C	D	E	F
25	NC	5V	*	*	3.3V	5V	GND
24	NC	*	5V	V(I/O)	*	*	GND
23	NC	3.3V	*	*	5V	*	GND
22	NC	*	GND	3.3V	*	*	GND
21	NC	3.3V	*	*	*	*	GND
20	NC	*	GND	V(I/O)	*	*	GND
19	NC	3.3V	*	*	GND	*	GND
18	NC	*	GND	3.3V	*	*	GND
17	NC	3.3V	IPMB SCL	IPMB SDA	GND	*	GND
16	NC	*	*	V(I/O)	*	*	GND
15	NC	3.3V	*	*	BDSEL#	*	GND
14-12	Key Area						
11	NC	*	*	*	GND	*	GND
10	NC	*	GND	3.3V	*	*	GND
9	NC	*	NC	*	GND	*	GND
8	NC	*	GND	V(I/O)	*	*	GND
7	NC	*	*	*	GND	*	GND
6	NC	*	CPCI_Present#	3.3V	*	*	GND
5	NC	RSV	RSV	RST#**	GND	*	GND
4	NC	IPMB PWR	Healthy#	V(I/O)	RSV	RSV	GND
3	NC	*	*	*	5V	*	GND
2	NC	TCK	5V	TMS	NC	TDI	GND
1	NC	5V	-12V	TRST#	+12V	5V	GND

Note ...



A * indicates that the signal normally present at this pin is disconnected from the CompactPCI bus when the CP6004-SA is inserted in a peripheral slot.

** When the CP6004-SA is inserted in a peripheral slot, the function of the RST# signal can be enabled or disabled.

Table 2-23: 64-bit CompactPCI Bus Connector J2 System Slot Pinout

PIN	Z	A	B	C	D	E	F
22	NC	GA4	GA3	GA2	GA1	GA0	GND
21	NC	CLK6	GND	RSV	RSV	RSV	GND
20	NC	CLK5	GND	RSV	GND	RSV	GND
19	NC	GND	GND	IPMB2_SDA	IPMB2_SCL	IPMB2_Alert	GND
18	NC	RSV	RSV	RSV	GND	RSV	GND
17	NC	RSV	GND	PRST#	REQ6#	GNT6#	GND
16	NC	RSV	RSV	DEG#	GND	RSV	GND
15	NC	RSV	GND	FAL#	REQ5#	GNT5#	GND
14	NC	AD[35]	AD[34]	AD[33]	GND	AD[32]	GND
13	NC	AD[38]	GND	V(I/O)	AD[37]	AD[36]	GND
12	NC	AD[42]	AD[41]	AD[40]	GND	AD[39]	GND
11	NC	AD[45]	GND	V(I/O)	AD[44]	AD[43]	GND
10	NC	AD[49]	AD[48]	AD[47]	GND	AD[46]	GND
9	NC	AD[52]	GND	V(I/O)	AD[51]	AD[50]	GND
8	NC	AD[56]	AD[55]	AD[54]	GND	AD[53]	GND
7	NC	AD[59]	GND	V(I/O)	AD[58]	AD[57]	GND
6	NC	AD[63]	AD[62]	AD[61]	GND	AD[60]	GND
5	NC	C/BE[5]#	NC	V(I/O)	C/BE[4]#	PAR64	GND
4	NC	V(I/O)	RSV	C/BE[7]#	GND	C/BE[6]#	GND
3	NC	CLK4	GND	GNT3#	REQ4#	GNT4#	GND
2	NC	CLK2	CLK3	SYSEN#	GNT2#	REQ3#	GND
1	NC	CLK1	GND	REQ1#	GNT1#	REQ2#	GND



Table 2-24: 64-bit CompactPCI Bus Connector J2 Peripheral Slot Pinout

PIN	Z	A	B	C	D	E	F
22	NC	GA4	GA3	GA2	GA1	GA0	GND
21	NC	*	GND	RSV	RSV	RSV	GND
20	NC	*	GND	RSV	GND	RSV	GND
19	NC	GND	GND	IPMB2_SDA	IPMB2_SCL	IPMB2_Alert	GND
18	NC	RSV	RSV	RSV	GND	RSV	GND
17	NC	RSV	GND	*	*	*	GND
16	NC	RSV	RSV	DEG#	GND	RSV	GND
15	NC	RSV	GND	FAL#	*	*	GND
14	NC	*	*	*	GND	*	GND
13	NC	*	GND	V(I/O)	*	*	GND
12	NC	*	*	*	GND	*	GND
11	NC	*	GND	V(I/O)	*	*	GND
10	NC	*	*	*	GND	*	GND
9	NC	*	GND	V(I/O)	*	*	GND
8	NC	*	*	*	GND	*	GND
7	NC	*	GND	V(I/O)	*	*	GND
6	NC	*	*	*	GND	*	GND
5	NC	*	NC	V(I/O)	*	*	GND
4	NC	V(I/O)	RSV	*	GND	*	GND
3	NC	*	GND	*	*	*	GND
2	NC	*	*	SYSEN#	*	*	GND
1	NC	*	GND	*	*	*	GND



Note ...

A * indicates that the signal normally present at this pin is disconnected from the CompactPCI bus when the CP6004-SA is inserted in a peripheral slot.



2.10.12.3 CompactPCI Rear I/O Connectors J3-J5 and Pinout

The CP6004-SA board provides optional rear I/O connectivity for peripherals. Standard PC interfaces are implemented and assigned to the front panel and to the rear I/O connectors J3, and J5. The J4 connector serves for providing rear I/O interfacing for the PMC module.

When the rear I/O module is used, the signals of some of the main board/front panel connectors are routed to the module interface. Thus, the rear I/O module makes it much easier to remove the CPU in the rack as there is practically no cabling on the CPU board.

For the system rear I/O feature a special backplane is necessary. The CP6004-SA with rear I/O is compatible with all standard 6U CompactPCI passive backplanes with rear I/O support.

The CP6004-SA conducts all I/O signals through the rear I/O connectors J3, J4 and J5.

Table 2-25: CompactPCI Rear I/O Connector J3 Pinout

PIN	Z	A	B	C	D	E	F
19	NC	RIO_VCC	RIO_VCC	RIO_3.3V	RIO_+12V	RIO_-12V	GND
18	NC	LPa_DA+	LPa_DA-	GND	LPa_DC+	LPa_DC-	GND
17	NC	LPa_DB+	LPa_DB-	GND	LPa_DD+	LPa_DD-	GND
16	NC	LPb_DA+	LPb_DA-	GND	LPb_DC+	LPb_DC-	GND
15	NC	LPb_DB+	LPb_DB-	GND	LPb_DD+	LPb_DD-	GND
14	NC	LPa:LINK	LPb:LINK	LPab:CT1	RSV	FAN:SENSE2	GND
13	NC	LPa:ACT	LPb:ACT	RSV	RSV	FAN:SENSE1	GND
12	NC	RSV	RSV	GND	RSV	RSV	GND
11	NC	RSV	RSV	GND	RSV	RSV	GND
10	NC	USB1:VCC	USB0:VCC	GND	USB3:VCC	USB2:VCC	GND
9	NC	USB1:D-	USB1:D+	GND	USB3:D-	USB3:D+	GND
8	NC	USB0:D-	USB0:D+	GND	USB2:D-	USB2:D+	GND
7	NC	RIO_3.3V	GPIO	GPI1	GPI2	SPEAKER	GND
6	NC	VGA:RED	VGA:GREEN	VGA:SDA	DEBUG:CLK	DEBUG:DAT	GND
5	NC	VGA:BLUE	VGA:HSYNC	VGA:VSYNC	VGA:SCL	RSV	GND
4	NC	RSV	RSV	SPB:CTS	SPB:TXD	RSV	GND
3	NC	SPB:RTS	SPB:RXD	RSV	RSV	RSV	GND
2	NC	SPA:RI	SPA:DTR	SPA:CTS	SPA:TXD	RSV	GND
1	NC	SPA:RTS	SPA:RXD	SPA:DSR	SPA:DCD	RIO_ID1	GND



Warning!

The RIO_XXX signals are power supply **OUTPUTS** to supply the rear I/O module with power. These pins **MUST NOT** be connected to any other power source, either within the backplane itself or within a rear I/O module.

Failure to comply with the above will result in damage to your board.



The following table describes the signals of the J3 connector.

Table 2-26: CompactPCI Rear I/O Connector J3 Signals

SIGNAL	DESCRIPTION
SPA	COMA signaling (RS-232)
SPB	COMB signaling (RS-232)
VGA	Graphic signaling
USB0 to USB3	USB port signaling
SPEAKER	Standard PC speaker
FAN	Fan speed sensing
DEBUG	Debug output
LPa	Rear I/O LAN Port A
LPb	Rear I/O LAN Port B
GPIO	General purpose digital input/output; 3.3 V only



Note ...

The VGA interface can be used both on the front panel and on the rear I/O. However, the VGA signals are switched to front I/O or rear I/O, depending on the uEFI BIOS setting.



Note ...

COMA can be used either on the front panel or on the rear I/O. It is not possible to use COMA on the front panel and on the rear I/O simultaneously.



Table 2-27: CompactPCI Rear I/O Connector J4 Pinout

PIN	Z	A	B	C	D	E	F
25	NC	PIM:1	PIM:3	GND	PIM:2	PIM:4	GND
24	NC	PIM:5	PIM:7	GND	PIM:6	PIM:8	GND
23	NC	NC	RIO_VCC	GND	NC	RIO_3.3V	GND
22	NC	PIM:9	PIM:11	GND	PIM:10	PIM:12	GND
21	NC	PIM:13	PIM:15	GND	PIM:14	PIM:16	GND
20	NC	GND	GND	GND	GND	GND	GND
19	NC	PIM:17	PIM:19	GND	PIM:18	PIM:20	GND
18	NC	PIM:21	PIM:23	GND	PIM:22	PIM:24	GND
17	NC	GND	GND	GND	GND	GND	GND
16	NC	PIM:25	PIM:27	GND	PIM:26	PIM:28	GND
15	NC	PIM:29	PIM:31	GND	PIM:30	PIM:32	GND
14 -12	Key Area						
11	NC	PIM:33	PIM:35	GND	PIM:34	PIM:36	GND
10	NC	PIM:37	PIM:39	GND	PIM:38	PIM:40	GND
9	NC	GND	GND	GND	GND	GND	GND
8	NC	PIM:41	PIM:43	GND	PIM:42	PIM:44	GND
7	NC	PIM:45	PIM:47	GND	PIM:46	PIM:48	GND
6	NC	GND	GND	GND	GND	GND	GND
5	NC	PIM:49	PIM:51	GND	PIM:50	PIM:52	GND
4	NC	PIM:53	PIM:55	GND	PIM:54	PIM:56	GND
3	NC	GND	GND	GND	GND	GND	GND
2	NC	PIM:57	PIM:59	GND	PIM:58	PIM:60	GND
1	NC	PIM:61	PIM:63	GND	PIM:62	PIM:64	GND

The signals from the J4 CompactPCI rear I/O connector are routed to the J27 (Jn4) PMC connector in such a way that they can only be used for low-speed signals.



Table 2-28: CompactPCI Rear I/O Connector J5 Pinout

PIN	Z	A	B	C	D	E	F
22	NC	GPI3	PWM1:OUT	GND	PWM2:OUT	BATT (3.0V)	GND
21	NC	HDA:SYNC	HDA:RST	GND	HDA:SDOUT	SYS_WP#	GND
20	NC	GPO0	HDA:SDIN1	GND	GPO1	HDA:SDIN2	GND
19	NC	GND	GND	GND	HDA:SDIN0	HDA:BITCLK	GND
18	NC	HDMI2:D0+	HDMI2:D0-	GND	GND	GND	GND
17	NC	HDMI2:D2+	HDMI2:D2-	GND	HDMI2:D1+	HDMI2:D1-	GND
16	NC	RSV	HDMI2:HPDET	GND	GPO2	GPO3	GND
15	NC	HDMI2:CLK+	HDMI2:CLK-	GND	HDMI2:SDA	HDMI2:SDC	GND
14	NC	GND	GND	GND	GND	GND	GND
13	NC	HDMI1:D0+	HDMI1:D0-	GND	HDMI1:D1+	HDMI1:D1-	GND
12	NC	HDMI1:D2+	HDMI1:D2-	GND	RSV	RSV	GND
11	NC	RSV	HDMI1:HPDET	GND	HDMI1:SDA	HDMI1:SDC	GND
10	NC	HDMI1:CLK+	HDMI1:CLK-	GND	RSV	RSV	GND
9	NC	GND	GND	GND	GND	GND	GND
8	NC	SATA3:TX+	SATA3:TX-	GND	SATA3:RX+	SATA3:RX-	GND
7	NC	GND	GND	GND	GND	GND	GND
6	NC	SATA2:TX+	SATA2:TX-	GND	SATA2:RX+	SATA2:RX-	GND
5	NC	GND	GND	GND	GND	GND	GND
4	NC	SATA1:TX+	SATA1:TX-	GND	SATA1:RX+	SATA1:RX-	GND
3	NC	GND	GND	GND	GND	GND	GND
2	NC	SATA0:TX+	SATA0:TX-	GND	SATA0:RX+	SATA0:RX-	GND
1	NC	GND	GND	GND	GND	GND	GND

The following table describes the signals of the J5 connector.

Table 2-29: CompactPCI Rear I/O Connector J5 Signals

SIGNAL	DESCRIPTION
SATA0..3	SATA Port 0..3 Signaling
HDMI1	HDMI signaling
HDMI2	HDMI signaling
HDA	High-definition audio signaling
PWM	Pulse width modulation output for fan
GPIO	General purpose digital input/output; 3.3 V only
SYS_WP#	System write protection for non-volatile memory devices; 3.3 V only
BATT (3.0V)	Back-up power input for RTC and CMOS RAM; 3.0 V only



Chapter **3**

Installation



This page has been intentionally left blank.



3. Installation

The CP6004-SA has been designed for easy installation. However, the following standard precautions, installation procedures, and general information must be observed to ensure proper installation and to preclude damage to the board, other system components, or injury to personnel.

3.1 Safety Requirements

The following safety precautions must be observed when installing or operating the CP6004-SA. Kontron assumes no responsibility for any damage resulting from failure to comply with these requirements.



Warning!

Due care should be exercised when handling the board due to the fact that the heat sink can get very hot. Do not touch the heat sink when installing or removing the board.

In addition, the board should not be placed on any surface or in any form of storage container until such time as the board and heat sink have cooled down to room temperature.



Caution!

If your board type is not specifically qualified as being hot swap capable, switch off the CompactPCI system power before installing the board in a free CompactPCI slot. Failure to do so could endanger your life or health and may damage your board or system.



Note...

Certain CompactPCI boards require bus master and/or rear I/O capability. If you are in doubt whether such features are required for the board you intend to install, please check your specific board and/or system documentation to make sure that your system is provided with an appropriate free slot in which to insert the board.



ESD Equipment!

This CompactPCI board contains electrostatically sensitive devices. Please observe the necessary precautions to avoid damage to your board:

- Discharge your clothing before touching the assembly. Tools must be discharged before use.
- Do not touch components, connector-pins or traces.
- If working at an anti-static workbench with professional discharging equipment, please do not omit to use it.



3.2 CP6004-SA Initial Installation Procedures

The following procedures are applicable only for the initial installation of the CP6004-SA in a system. Procedures for standard removal and hot swap operations are found in their respective chapters.

To perform an initial installation of the CP6004-SA in a system proceed as follows:

1. Ensure that the safety requirements indicated Chapter 3.1 are observed.



Warning!

Failure to comply with the instruction above may cause damage to the board or result in improper system operation.

2. Ensure that the board is properly configured for operation in accordance with application requirements before installing. For information regarding the configuration of the CP6004-SA refer to Chapter 4. For the installation of CP6004-SA specific peripheral devices and rear I/O devices refer to the appropriate sections in Chapter 3.



Warning!

Care must be taken when applying the procedures below to ensure that neither the CP6004-SA nor other system boards are physically damaged by the application of these procedures.

3. To install the CP6004-SA perform the following:

1. Ensure that no power is applied to the system before proceeding.



Warning!

Even though power may be removed from the system, the CP6004-SA front panel cables and, when installed, the RIO transition module front panel cables may have power applied which comes from an external source.

In addition, these cables may be connected to devices that can be damaged by electrostatic discharging or short-circuiting of pins.

It is the responsibility of the system designer or integrator to ensure that appropriate measures are taken to preclude damage to the system or injury to personnel which may arise from the handling of these cables (connecting or disconnecting).

Kontron disclaims all liability for damages or injuries resulting from failure to comply with the above.



Warning!

When performing the next step, **DO NOT** push the board into the backplane connectors. Use the ejector handles to seat the board into the backplane connectors.

2. Carefully insert the board into the slot designated by the application requirements for the board until it makes contact with the backplane connectors.



3. Using both ejector handles, engage the board with the backplane. When the ejector handles are locked, the board is engaged.
4. Fasten the two front panel retaining screws.
5. Connect all external interfacing cables to the board as required.
6. Ensure that the board and all required interfacing cables are properly secured.

The CP6004-SA is now ready for initial operation. Except for the uEFI BIOS, at this point there is no other software installed. For software installation and further operation of the CP6004-SA, refer to appropriate CP6004-SA software (uEFI BIOS, BSP, OS), application, and system documentation.

3.3 Standard Removal Procedures

To remove the board proceed as follows:

1. Ensure that the safety requirements indicated in Chapter 3.1 are observed. Particular attention must be paid to the warning regarding the heat sink!



Warning!

Care must be taken when applying the procedures below to ensure that neither the CP6004-SA nor system boards are physically damaged by the application of these procedures.

2. Ensure that no power is applied to the system before proceeding.



Warning!

Even though power may be removed from the system, the CP6004-SA front panel cables and, when installed, the RIO transition module front panel cables may have power applied which comes from an external source.

In addition, these cables may be connected to devices that can be damaged by electrostatic discharging or short-circuiting of pins.

It is the responsibility of the system designer or integrator to ensure that appropriate measures are taken to preclude damage to the system or injury to personnel which may arise from the handling of these cables (connecting or disconnecting).

Kontron disclaims all liability for damages or injuries resulting from failure to comply with the above.

3. Disconnect any interfacing cables that may be connected to the board.
4. Unscrew the front panel retaining screws.



Warning!

Due care should be exercised when handling the board due to the fact that the heat sink can get very hot. Do not touch the heat sink when changing the board.

5. Disengage the board from the backplane by first unlocking the board ejection handles and then by pressing the handles as required until the board is disengaged.
6. After disengaging the board from the backplane, pull the board out of the slot.
7. Dispose of the board as required.



3.4 Hot Swap Procedures

The CP6004-SA is designed for hot swap operation. When installed in the system slot, it is capable of supporting peripheral board hot swapping. When installed in a peripheral slot, its hot swap capabilities depend on the type of backplane in use and the system controller's capabilities. The reason for this being that communications with the system controller requires either front panel Ethernet I/O or use of a packet switching backplane. In any event, hot swap is also a function of the application running on the CP6004-SA.

3.4.1 System Master Hot Swap

Hot swapping of the CP6004-SA itself when used as the system controller is possible, but will result in any event in a cold start of the CP6004-SA and consequently a reinitialization of all peripheral boards. Exactly what transpires in such a situation is a function of the application and is not addressed in this manual. The user must refer to appropriate application documentation for applicable procedures for this case. In any event, the safety requirements above must be observed.

3.4.2 Peripheral Hot Swap Procedure

This procedure assumes that the system supports hot swapping, and that the replacement for the board to be hot swapped is configured hardware- and software-wise for operation in the application.

To hot swap the CP6004-SA proceed as follows:

1. Ensure that the safety requirements indicated in Chapter 3.1 are observed. Particular attention must be paid to the warning regarding the heat sink!



Warning!

Care must be taken when applying the procedures below to ensure that neither the CP6004-SA nor other system boards are physically damaged by the application of these procedures.

2. Unlock both board ejection handles ensuring that the bottom handle has activated the hot swap switch (this occurs with a very small amount of movement of the handle).



Note ...

What transpires at this time is a function of the application. If hot swap is supported by the application, then the blue HS LED should light up after a short time period. This indicates that the system has recognized that the CP6004-SA is to be hot swapped and now indicates to the operator that hot swapping of the CP6004-SA may proceed.

If the blue HS LED does not light up after a short time period, either the system does not support hot swap or a malfunction has occurred. In this event, the application is responsible for handling this situation and must provide the operator with appropriate guidance to remedy the situation.

3. After approximately 1 to 15 seconds, the blue HS LED should light up. If the LED lights up, proceed with the next step of this procedure. If the LED does not light up, refer to appropriate application documentation for further action.

4. Disconnect any interfacing cables that may be connected to the board.

**Warning!**

The CP6004-SA front panel cables and, when installed, the RIO transition module front panel cables may have power applied which comes from an external source.

In addition, these cables may be connected to devices that can be damaged by electrostatic discharging or short-circuiting of pins.

It is the responsibility of the system designer or integrator to ensure that appropriate measures are taken to preclude damage to the system or injury to personnel which may arise from the handling of these cables (connecting or disconnecting).

Kontron disclaims all liability for damages or injuries resulting from failure to comply with the above.

5. Unscrew the front panel retaining screws.

**Warning!**

Due care should be exercised when handling the board due to the fact that the heat sink can get very hot. Do not touch the heat sink when changing the board.

6. Using the ejector handles, disengage the board from the backplane and carefully remove it from the system.
7. Dispose of the “old” board as required observing the safety requirements indicated in Chapter 3.1.
8. Obtain the replacement CP6004-SA board.

**Warning!**

When performing the next step, **DO NOT** push the board into the backplane connectors. Use the ejector handles to seat the board into the backplane connectors.

9. Carefully insert the “new” board into the “old” board slot until it makes contact with the backplane connectors.
10. Using both ejector handles, engage the board with the backplane. When the ejector handles are locked, the board is engaged.
11. Fasten the front panel retaining screws.
12. Connect all required interfacing cables to the board.
Hot swap of the CP6004-SA is now complete.



3.5 Installation of CP6004-SA Peripheral Devices

The CP6004-SA is designed to accommodate various peripheral devices, such as USB devices, SATA devices, PMC/XMC devices, rear I/O devices, etc. The following figure shows the placement of the SATA Flash module and the MMADP-SATA01 module, which is required for connecting an onboard HDD/SSD to the CP6004-SA.

Figure 3-1: Connecting a Peripheral Device to the CP6004-SA

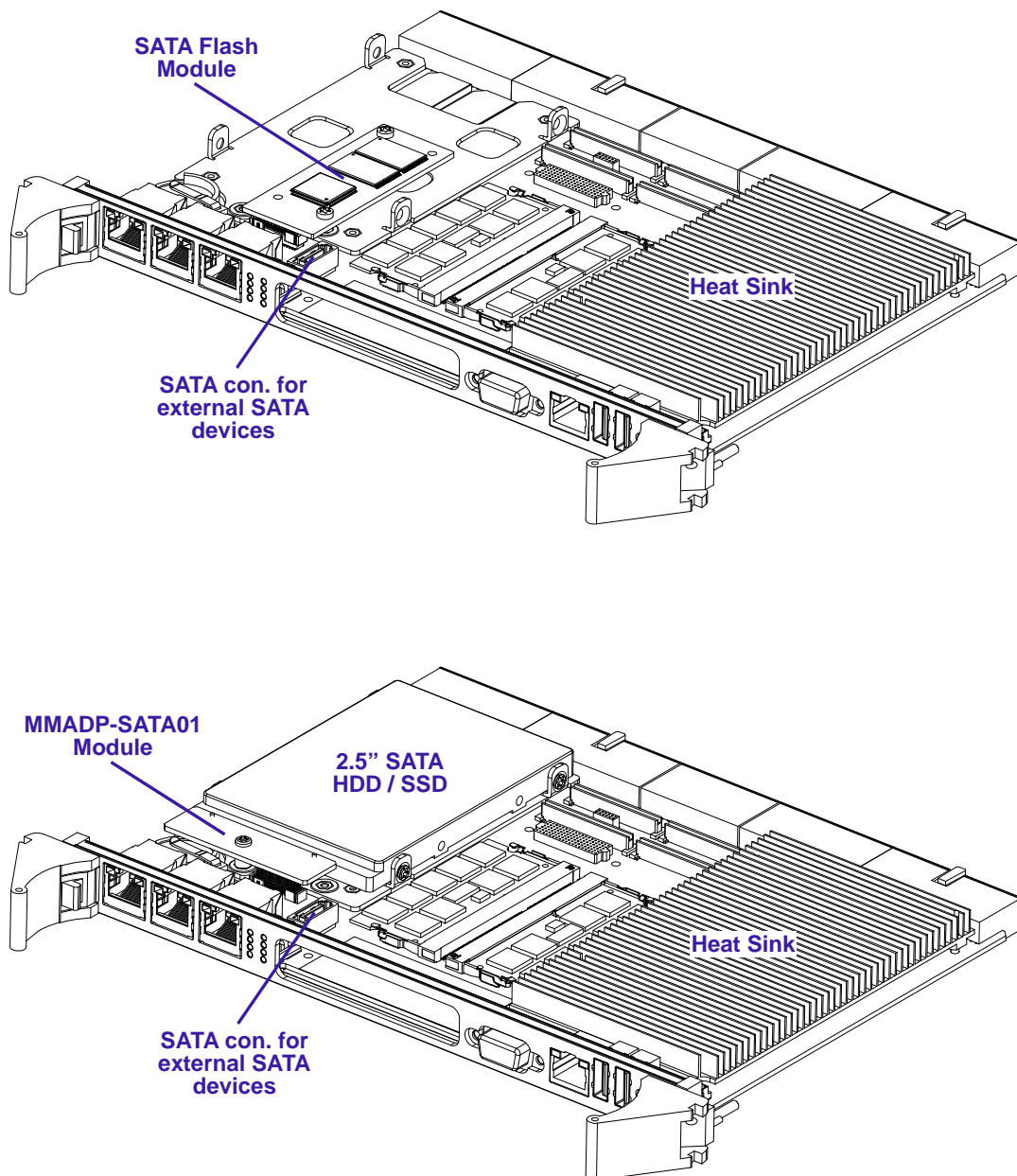

The following chapters provide information regarding installation aspects of peripheral devices.





3.5.1 USB Device Installation

The CP6004-SA supports all USB Plug and Play computer peripherals (e.g. keyboard, mouse, printer, etc.).



Note ...

All USB devices may be connected or removed while the host or other peripherals are powered up.

3.5.2 SATA Flash Module Installation

A SATA Flash module may be connected to the CP6004-SA via the onboard connector, J17.

This optionally available module must be physically installed on the CP6004-SA prior to installation of the CP6004-SA in a system.

During installation it is necessary to ensure that the SATA Flash module is properly seated in the onboard connector J17, i.e. the pins are aligned correctly and not bent.



Note ...

Only qualified SATA Flash modules from Kontron are authorized for use with the CP6004-SA. Failure to comply with the above will void the warranty and may result in damage to the board or the system.

3.5.3 Installation of External SATA Devices

The following information pertains to external SATA devices which may be connected to the CP6004-SA via normal cabling.

Some symptoms of incorrectly installed SATA devices are:

- Device on a SATA channel does not spin up: check power cables and cabling. May also result from a bad power supply or SATA device.
The SATA connector on the CP6004-SA provides only a data connection. The power for this device must be supplied by a separate connector. For further information, refer to the respective documentation of the device.
- SATA device fail message at boot-up: may be a bad cable or lack of power going to the drive.

3.5.4 Onboard 2.5" HDD/SSD Installation

One 2.5" SATA HDD/SSD may be directly connected to the board via the J17 connector and the adapter module MMADP-SATA01. This module is required to provide SATA interfacing to the HDD/SSD. For further information regarding the MMADP-SATA01 module, refer to Appendix A.



3.6 PMC/XMC Module Installation

The CP6004-SA supports the installation of a PMC module via the connectors J21 to J24 or an XMC module via the connector J20.

For the initial installation and standard removal of all PMC/XMC modules, refer to the documentation provided with the module.

Prior to installation or removal, ensure that the safety requirements indicated in Chapter 3.1 of this user guide are observed. Particular attention must be paid to the warning regarding the heat sink!



Note ...

Only XMC modules with one board-to-board connector (P15) can be used with the CP6004-SA.

3.6.1 Rear I/O Device Installation

For physical installation of rear I/O devices, refer to the documentation provided with the device itself.



Note ...

COMA can be used either on the front panel or on rear I/O. It is not possible to use COMA on the front panel and the rear I/O simultaneously.





3.7 Battery Replacement

The CP6004-SA is provided with a 3.0 V “coin cell” lithium battery of type CR2025 approved by UL. The battery is used for RTC data storage.

**Warning!**

Use only batteries of type CR2025 approved by UL.

Replacement of the battery by an incorrect type may result in explosion.

To replace the battery, proceed as follows:

- Turn off power.
- Remove the battery.
- Place the new battery in the socket.
- Make sure that you insert the battery the right way round. The plus pole must be on the top!

**Note ...**

The user must be aware that the battery's operational temperature range is less than the CP6004-SA's storage temperature range.

For exact range information, refer to the battery manufacturer's specifications.

**Note ...**

Care must be taken to ensure that the battery is correctly replaced.

Dispose of used batteries according to the manufacturer's instructions.

The typical life expectancy of a 170 mAh battery (CR2025) is 5 - 6 years with an average on-time of 8 hours per working day at an operating temperature of 30°C. However, this typical value varies considerably because the life expectancy is dependent on the operating temperature and the standby time (shutdown time) of the system in which it operates.

To ensure that the lifetime of the battery has not been exceeded it is recommended to exchange the battery after 4 - 5 years.

3.8 Software Installation

The installation of the Ethernet and all other onboard peripheral drivers is described in detail in the relevant Driver Kit files.

Installation of an operating system is a function of the OS software and is not addressed in this manual. Refer to appropriate OS software documentation for installation.

**Note ...**

Users working with pre-configured operating system installation images for Plug and Play compliant operating systems, for example Windows®, must take into consideration that the stepping and revision ID of the chipset and/or other onboard PCI devices may change. Thus, a re-configuration of the operating system installation image deployed for a previous chipset stepping or revision ID is in most cases required. The corresponding operating system will detect new devices according to the Plug and Play configuration rules.



This page has been intentionally left blank.





Chapter **4**

Configuration



This page has been intentionally left blank.



4. Configuration

4.1 DIP Switches SW1, SW2 and SW3 Configuration

The CP6004-SA is equipped with one 4-bit DIP switch, SW1, and two 2-bit DIP switches, SW2 and SW3, which enable the board to be configured according to the application requirements. DIP Switch SW1 is used for uEFI BIOS boot configuration. DIP Switch SW2 is used for configuring the CompactPCI interface. DIP Switch SW3 is used for configuring the PMC interface.

4.1.1 DIP Switch SW1 Configuration

Figure 4-1: DIP Switch SW1

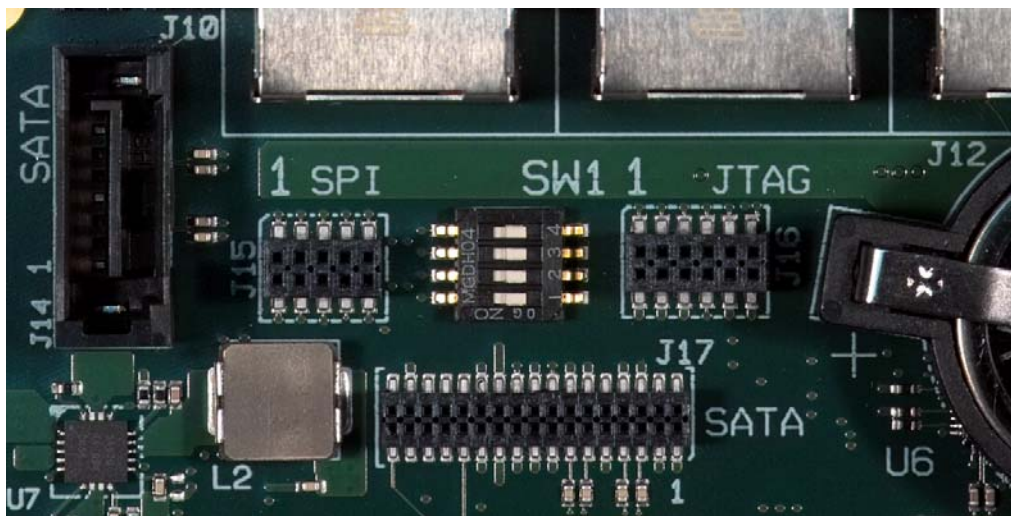

Table 4-1: DIP Switch SW1 for Boot Configuration

SWITCH 1	SETTING	DESCRIPTION
1	<i>OFF</i>	<i>Boot-up with POST Code indication on the General Purpose LEDs</i>
	ON	Boot-up with no POST Code indication on the General Purpose LEDs
2	<i>OFF</i>	<i>Boot from the standard SPI boot flash</i>
	ON	Boot from the recovery SPI boot flash
3	<i>OFF</i>	Reserved
	ON	
4	<i>OFF</i>	<i>Boot using the currently saved uEFI BIOS settings</i>
	ON	Clear the uEFI BIOS settings and use the default values

The default settings of the DIP switches are indicated by using italic bold.



Note ...

If the DIP switch SW1, switch 2, is set to ON, the SPI boot flash selection cannot be overwritten by the IPMI controller.



To clear the uEFI BIOS settings, proceed as follows:

1. Set the DIP Switch SW1, switch 4, to the ON position.
2. Apply power to the system.
3. After 30 seconds, remove power from the system.
During this time period of approx. 30 seconds, no messages are displayed.
4. Set the DIP Switch SW1, switch 4 to the OFF position.

4.1.2 DIP Switches SW2 and SW3 Configuration

Figure 4-2: DIP Switches SW2 and SW3

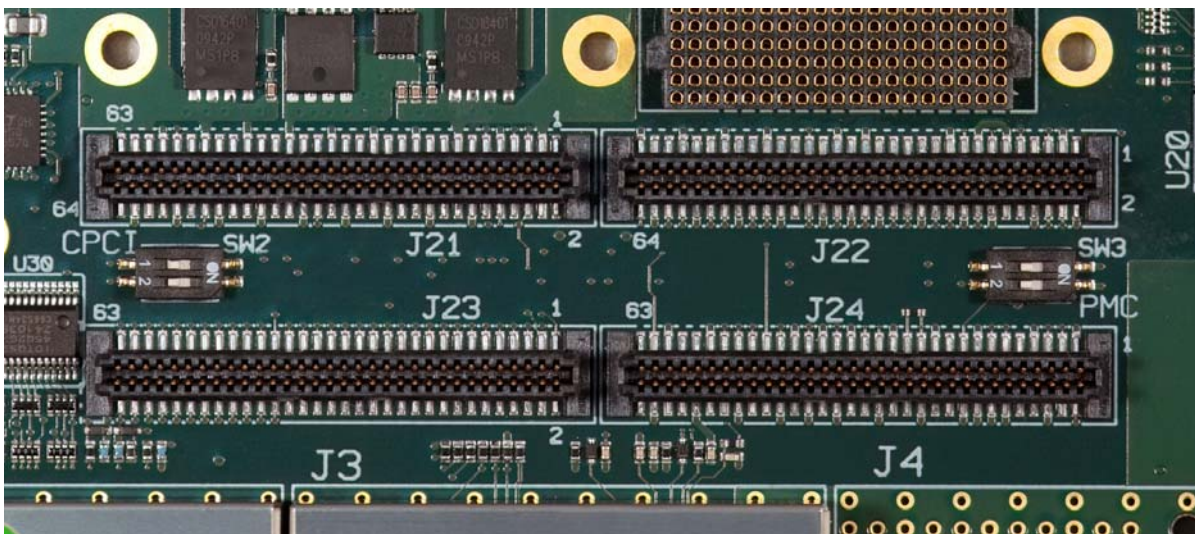

Table 4-2: DIP Switch SW2 for CompactPCI Interface Configuration

SWITCH 1	SETTING	DESCRIPTION
1	<i>OFF</i>	<i>PCI 33 MHz/66 MHz auto detection via the CompactPCI backplane</i>
	ON	PCI frequency configured to 33 MHz
2	<i>OFF</i>	<i>PCI/PCI-X mode auto detection via the CompactPCI backplane</i>
	ON	CP6004-SA configured to PCI mode

Table 4-3: DIP Switch SW3 for PMC Interface Configuration

SWITCH 1	SETTING	DESCRIPTION
1	<i>OFF</i>	<i>PCI/PCI-X frequency multiplier configured to 33 MHz</i>
	ON	PCI/PCI-X frequency multiplier configured to 25 MHz
2	<i>OFF</i>	<i>PCI/PCI-X mode auto detection via the PMC module</i>
	ON	PMC interface configured to PCI mode

The default settings of the DIP switches are indicated by using italic bold.





4.2 Jumper Description

The CP6004-SA has three jumpers JP1, JP2, and JP3 reserved for further use.

4.3 I/O Address Map

The following table indicates the CP6004-SA-specific registers.

Table 4-4: I/O Address Map

ADDRESS	DEVICE
0x080 -	uEFI BIOS POST Code Low Byte Register (POSTL)
0x081	uEFI BIOS POST Code High Byte Register (POSTH)
0x082 - 0x083	Reserved
0x084	Debug Low Byte Register (DBGL)
0x085	Debug High Byte Register (DBGH)
0x280	Status Register 0 (STAT0)
0x281	Status Register 1 (STAT1)
0x282	Control Register 0 (CTRL0)
0x283	Control Register 1 (CTRL1)
0x284	Device Protection Register (DPROT)
0x285	Reset Status Register (RSTAT)
0x286	Board Interrupt Configuration Register (BICFG)
0x287	Status Register 2 (STAT2)
0x288	Board ID High Byte Register (BIDH)
0x289	Board and PLD Revision Register (BREV)
0x28A	Geographic Addressing Register (GEOAD)
0x28B	Reserved
0x28C	Watchdog Timer Control Register (WTIM)
0x28D	Board ID Low Byte Register (BIDL)
0x28E - 0x28F	Reserved
0x290	LED Configuration Register (LCFG)
0x291	LED Control Register (LCTRL)
0x292	General Purpose Output Register (GPOUT)
0x293	General Purpose Input Register (GPIN)
0x294 - 0x29C	Reserved
0xCA2; 0xCA3	IPMI KCS interface



4.4 CP6004-SA-Specific Registers

The following registers are special registers which the CP6004-SA uses to watch the onboard hardware special features and the CompactPCI control signals.

Normally, only the system uEFI BIOS uses these registers, but they are documented here for application use as required.



Note ...

Take care when modifying the contents of these registers as the system uEFI BIOS may be relying on the state of the bits under its control.

4.4.1 Status Register 0 (STAT0)

The Status Register 0 holds general/common status information.

Table 4-5: Status Register 0 (STAT0)

REGISTER NAME		STATUS REGISTER 0 (STAT0)		
ADDRESS		0x280		
BIT	NAME	DESCRIPTION	RESET VALUE	ACCESS
7	HSBS	Hot swap handle status: 0 = Hot swap handle in closed position 1 = Hot swap handle in open position	N/A	R
6	BBEI	uEFI BIOS boot end indication: 0 = uEFI BIOS is booting 1 = uEFI BIOS boot is finished	0	R
5 - 4	BFSS	SPI boot flash selection status: 00 = Standard SPI boot flash active 01 = Recovery SPI boot flash active 10 = External SPI boot flash active 11 = Reserved	N/A	R
3	DIP4	DIP switch SW1, switch 4	N/A	R
2	DIP3	DIP switch SW1, switch 3	N/A	R
1	DIP2	DIP switch SW1, switch 2	N/A	R
0	DIP1	DIP switch SW1, switch 1	N/A	R





4.4.2 Status Register 1 (STAT1)

The Status Register 1 holds board-specific status information.

Table 4-6: Status Register 1 (STAT1)

REGISTER NAME		STATUS REGISTER 1 (STAT1)		
ADDRESS		0x281		
BIT	NAME	DESCRIPTION	RESET VALUE	ACCESS
7	C66EN	CPCI PCI speed (M66EN signal): 0 = 33 MHz 1 = 66 MHz	N/A	R
6	CVIO	CPCI backplane V/I/O voltage configuration: 0 = 3.3V V/I/O voltage 1 = 5V V/I/O voltage	N/A	R
5	P66EN	PMC PCI speed (M66EN signal): 0 = 33 MHz 1 = 66 MHz	N/A	R
4	Res.	Reserved	0	R
3	CSYS	CPCI system slot identification (SYSEN# signal): 0 = Installed in a system slot 1 = Installed in a peripheral slot	N/A	R
2	CENUM	CPCI system enumeration (ENUM# signal): 0 = Indicates the insertion or removal of a hot swap system board 1 = No hot swap event	N/A	R
1	CFAL	CPCI power supply status (FAL# signal): 0 = Power supply failure 1 = Power in normal state	N/A	R
0	CDEG	CPCI power supply status (DEG# signal): 0 = Power derating 1 = Power in normal state	N/A	R

4.4.3 Control Register 0 (CTRL0)

The Control Register 0 holds general/common control information.

Table 4-7: Control Register 0 (CTRL0)

REGISTER NAME		CONTROL REGISTER 0 (CTRL0)		
ADDRESS		0x282		
BIT	NAME	DESCRIPTION	RESET VALUE	ACCESS
7 - 6	VGAM	VGA mode configuration: 00 = Automatic VGA Front Detection 01 = Front VGA (uEFI BIOS default) 10 = Rear VGA 11 = VGA disabled	N/A	R/W
5 - 0	Res.	Reserved	000000	R

4.4.4 Control Register 1 (CTRL1)

The Control Register 1 holds board-specific control information.

Table 4-8: Control Register 1 (CTRL1)

REGISTER NAME		CONTROL REGISTER 1 (CTRL1)		
ADDRESS		0x283		
BIT	NAME	DESCRIPTION	RESET VALUE	ACCESS
7	SRST	SATA Flash module reset: 0 = Reset of SATA Flash module 1 = SATA Flash module running	1	R/W
6	VRST	Integrated graphics controller configuration: 0 = Graphics controller disabled 1 = Graphics controller enabled	1	R
5	Res.	Reserved	0	R
4	CRST	Board reset via CPCI interface when installed in peripheral slot: 0 = Disable board reset via CPCI interface 1 = Enable board reset via CPCI interface	0	R/W
3	XRST	Board reset via XMC device: 0 = Disable board reset via XMC device 1 = Enable board reset via XMC device	0	R/W
2-0	Res.	Reserved	000	R



4.4.5 Device Protection Register (DPROT)

The Device Protection Register holds the write protect signals for flash devices.

Table 4-9: Device Protection Register (DPROT)

REGISTER NAME		DEVICE PROTECTION REGISTER (DPROT)		
ADDRESS		0x284		
BIT	NAME	DESCRIPTION	RESET VALUE	ACCESS
7	SWP	System write protection: 0 = Onboard non-volatile memory devices not write protected 1 = Onboard non-volatile memory devices write protected This bit reflects the state of the system hardware write protection signal SYS_WP#.	0	R
6 - 2	Res.	Reserved	00000	R
1	EEWP	EEPROM write protection: 0 = EEPROM not write protected 1 = EEPROM write protected Writing a '1' to this bit sets the bit. If this bit is set, it cannot be cleared.	0	R/W
0	BFWP	SPI flash write protection: 0 = SPI flash not write protected 1 = SPI flash write protected Writing a '1' to this bit sets the bit. If this bit is set, it cannot be cleared.	0	R/W



4.4.6 Reset Status Register (RSTAT)

The Reset Status Register is used to determine the host's reset source.

Table 4-10: Reset Status Register (RSTAT)

REGISTER NAME		RESET STATUS REGISTER (RSTAT)		
ADDRESS		0x285		
BIT	NAME	DESCRIPTION	RESET VALUE	ACCESS
7	PORS	Power-on reset status: 0 = System reset generated by software (warm reset) 1 = System reset generated by power-on (cold reset) Writing a '1' to this bit clears the bit.	N/A	R/W
6	Res.	Reserved	0	R
5	SRST	Software reset status: 0 = Reset is logged by the IPMI controller 1 = Reset is not logged by IPMI controller The uEFI BIOS/software sets this bit to inform the IPMI controller that the next reset should not be logged.	0	R/W
4	Res.	Reserved	0	R
3	IPRS	IPMI controller reset status: 0 = System reset not generated by IPMI 1 = System reset generated by IPMI Writing a '1' to this bit clears the bit.	0	R/W
2	FPRS	Front panel push button reset status: 0 = System reset not generated by front panel reset 1 = System reset generated by front panel reset Writing a '1' to this bit clears the bit.	0	R/W
1	CPRS	CompactPCI reset status (PRST signal): 0 = System reset not generated by CPCI reset input 1 = System reset generated by CPCI reset input Writing a '1' to this bit clears the bit.	0	R/W
0	WTRS	Watchdog timer reset status: 0 = System reset not generated by Watchdog timer 1 = System reset generated by Watchdog timer Writing a '1' to this bit clears the bit.	0	R/W



Note ...

The Reset Status Register is set to the default values by power-on reset, not by a warm reset.





4.4.7 Board Interrupt Configuration Register (BICFG)

The Board Interrupt Configuration Register holds a series of bits defining the interrupt routing for the Watchdog. If the Watchdog timer fails, it can generate an IRQ5 interrupt.

The enumeration signal is generated by a hot swap compatible board after insertion and prior to removal. The system uses this interrupt signal to force software to configure the new board. The derate signal indicates that the power supply is beginning to derate its power output.

Table 4-11: Board Interrupt Configuration Register (BICFG)

REGISTER NAME		BOARD INTERRUPT CONFIGURATION REGISTER (BICFG)		
ADDRESS		0x286		
BIT	NAME	DESCRIPTION	RESET VALUE	ACCESS
7	Res.	Reserved	0	R/W
6	CFICF	CPCI fail signal interrupt configuration (FAL# signal): 0 = Disabled 1 = Enabled	0	R/W
5	CEICF	CPCI enumeration signal to IRQ5 routing (ENUM# signal): 0 = Disabled 1 = Enabled	0	R/W
4	CDICF	CPCI derate signal to IRQ5 routing (DEG# signal): 0 = Disabled 1 = Enabled	0	R/W
3 - 2	KICF	IPMI KCS interrupt configuration 00 = Disabled 01 = IRQ11 10 = IRQ10 11 = Reserved	00	R
1 - 0	WICF	Watchdog interrupt configuration: 00 = Disabled 01 = IRQ5 10 = Reserved 11 = Reserved	00	R/W



4.4.8 Status Register 2 (STAT2)

The Status Register 2 holds board-specific status information.

Table 4-12: Status Register 2 (STAT2)

REGISTER NAME		STATUS REGISTER 2 (STAT2)		
ADDRESS		0x287		
BIT	NAME	DESCRIPTION	RESET VALUE	ACCESS
7 - 2	Res.	Reserved	000000	R
1	XAP	XMC device in slot A: 0 = Not present 1 = Present	N/A	R
0	Res.	Reserved	0	R

4.4.9 Board ID High Byte Register (BIDH)

Each Kontron board is provided with a unique 16-bit board-type identifier in the form of a hexadecimal number. The Board ID High Byte Register is located in the address 0x288. The Board ID Low Byte Register is located in the address 0x28D.

Table 4-13: Board ID High Byte Register (BIDH)

REGISTER NAME		BOARD ID HIGH BYTE REGISTER (BIDH)		
ADDRESS		0x288		
BIT	NAME	DESCRIPTION	RESET VALUE	ACCESS
7 - 0	BIDH	Board identification: CP6004-SA: 0xB3D0	0xB3	R





4.4.10 Board and PLD Revision Register (BREV)

The Board and PLD Revision Register signals to the software when differences in the board and the Programmable Logic Device (PLD) require different handling by the software. It starts with the value 0x00 and will be incremented with each change in hardware as development continues.

Table 4-14: Board and PLD Revision Register (BREV)

REGISTER NAME		BOARD AND PLD REVISION REGISTER (BREV)		
ADDRESS		0x289		
BIT	NAME	DESCRIPTION	RESET VALUE	ACCESS
7 - 4	BREV	Board revision	N/A	R
3 - 0	PREV	PLD revision	N/A	R

4.4.11 Geographic Addressing Register (GEOAD)

This register holds the CompactPCI geographic address (site number) used to assign the Intelligent Platform Management Bus (IPMB) address to the CP6004-SA.

Table 4-15: Geographic Addressing Register (GEOAD)

REGISTER NAME		GEOGRAPHIC ADDRESSING REGISTER (GEOAD)		
ADDRESS		0x28A		
BIT	NAME	DESCRIPTION	RESET VALUE	ACCESS
7 - 5	Res.	Reserved	000	R
4 - 0	GA	Geographic address	N/A	R



Note ...

The Geographic Addressing Register is set to the default values by power-on reset, not by warm reset.



4.4.12 Watchdog Timer Control Register (WTIM)

The CP6004-SA has one Watchdog timer provided with a programmable timeout ranging from 125 msec to 4096 sec. Failure to strobe the Watchdog timer within a set time period results in a system reset or an interrupt. The interrupt mode can be configured via the Board Interrupt Configuration Register (0x286).

There are four possible modes of operation involving the Watchdog timer:

- Timer only mode
- Reset mode
- Interrupt mode
- Dual stage mode

At power on the Watchdog is not enabled. If not required, it is not necessary to enable it. If required, the bits of the Watchdog Timer Control Register must be set according to the application requirements. To operate the Watchdog, the mode and time period required must first be set and then the Watchdog enabled. Once enabled, the Watchdog can only be disabled or the mode changed by powering down and then up again. To prevent a Watchdog timeout, the Watchdog must be retriggered before timing out. This is done by writing a '1' to the WTR bit. In the event a Watchdog timeout does occur, the WTE bit is set to '1'. What transpires after this depends on the mode selected.

The four operational Watchdog timer modes can be configured by the WMD[1:0] bits, and are described as follows:

Timer only mode - In this mode the Watchdog is enabled using the required timeout period. Normally, the Watchdog is retriggered by writing a '1' to the WTR bit. In the event a timeout occurs, the WTE bit is set to '1'. This bit can then be polled by the application and handled accordingly. To continue using the Watchdog, write a '1' to the WTE bit, and then retrigger the Watchdog using WTR. The WTE bit retains its setting as long as no power down-up is done. Therefore, this bit may be used to verify the status of the Watchdog.

Reset mode - This mode is used to force a hard reset in the event of a Watchdog timeout. In addition, the WTE bit is not reset by the hard reset, which makes it available if necessary to determine the status of the Watchdog prior to the reset.

Interrupt mode - This mode causes the generation of an interrupt in the event of a Watchdog timeout. The interrupt handling is a function of the application. If required, the WTE bit can be used to determine if a Watchdog timeout has occurred.

Dual stage mode - This is a complex mode where in the event of a timeout two things occur: 1) an interrupt is generated, and 2) the Watchdog is retriggered automatically. In the event a second timeout occurs immediately following the first timeout, a hard reset will be generated. The second timeout period is the same as the first. If the Watchdog is retriggered normally, operation continues. The interrupt generated at the first timeout is available to the application to handle the first timeout if required. As with all of the other modes, the WTE bit is available for application use.



Table 4-16: Watchdog Timer Control Register (WTIM)

REGISTER NAME		WATCHDOG TIMER CONTROL REGISTER (WTIM)		
ADDRESS		0x28C		
BIT	NAME	DESCRIPTION	RESET VALUE	ACCESS
7	WTE	Watchdog timer expired status bit 0 = Watchdog timer has not expired 1 = Watchdog timer has expired. Writing a '1' to this bit resets it to 0.	0	R/W
6 - 5	WMD	Watchdog mode 00 = Timer only mode 01 = Reset mode 10 = Interrupt mode 11 = Cascaded mode (dual-stage mode)	00	R/W
4	WEN/WTR	Watchdog enable/Watchdog trigger control bit: 0 = Watchdog timer not enabled Prior to the Watchdog being enabled, this bit is known as WEN. After the Watchdog is enabled, it is known as WTR. Once the Watchdog timer has been enabled, this bit cannot be reset to 0. As long as the Watchdog timer is enabled, it will indicate a '1'. 1 = Watchdog timer enabled Writing a '1' to this bit causes the Watchdog to be retriggered to the timer value indicated by bits WTM[3:0].	0	R/W
3 - 0	WTM	Watchdog timeout settings: 0000 = 0.125 s 0001 = 0.25 s 0010 = 0.5 s 0011 = 1 s 0100 = 2 s 0101 = 4 s 0110 = 8 s 0111 = 16 s 1000 = 32 s 1001 = 64 s 1010 = 128 s 1011 = 256 s 1100 = 512 s 1101 = 1024 s 1110 = 2048 s 1111 = 4096 s	0000	R/W



4.4.13 Board ID Low Byte Register (BIDL)

Each Kontron board is provided with a unique 16-bit board-type identifier in the form of a hexadecimal number. The Board ID Low Byte Register is located in the address 0x28D. The Board ID High Byte Register is located in the address 0x288.

Table 4-17: Board ID Low Byte Register (BIDL)

REGISTER NAME		BOARD ID LOW BYTE REGISTER (BIDL)		
ADDRESS		0x28D		
BIT	NAME	DESCRIPTION	RESET VALUE	ACCESS
7 - 0	BIDL	Board identification: CP6004-SA: 0xB3D0	0xD0	R





4.4.14 LED Configuration Register (LCFG)

The LED Configuration Register holds a series of bits defining the onboard configuration of the General Purpose LEDs (LED 0..3). For the location of the General Purpose LEDs, refer to Figure 1-6.

Table 4-18: LED Configuration Register (LCFG)

REGISTER NAME		LED CONFIGURATION REGISTER (LCFG)		
ADDRESS		0x290		
BIT	NAME	DESCRIPTION	RESET VALUE	ACCESS
7-4	Res.	Reserved	0000	R
3-0	LCON	LED Configuration: 0000 = POST ¹⁾ 0001 = Mode A ²⁾ 0010 - 1111 = Reserved	0001	R/W

¹⁾ In uEFI BIOS POST mode, the General Purpose LEDs build a binary vector to display uEFI BIOS POST code during the pre-boot phase. In doing so, the higher 4-bit nibble of the 8-bit uEFI BIOS POST code is displayed followed by the lower nibble followed by a pause. The uEFI BIOS POST code is displayed in general in green color.

LED3: POST bit 3 and bit 7 (green)
LED2: POST bit 2 and bit 6 (green)
LED1: POST bit 1 and bit 5 (green)
LED0: POST bit 0 and bit 4 (green)

²⁾ Configured for Mode A, the General Purpose LEDs are dedicated to functions as follows:

LED3: LED 3 (red/green/amber)
LED2: LED 2 (red/green/amber)
LED1: LED 1 (red/green/amber)
LED0: LED 0 (red/green/amber)

Besides the configurable functions described above, the General Purpose LEDs fulfill also a basic debug function during the power-up phase as long as the first access to Port 80 is processed. If an LED lights red and stays red, than a basic error is present on the board. The following debug functions are defined and displayed during this initialization phase.

LED3: PGOOD, Power Good status not reached (red)
LED2: CPU catastrophic error (red)
LED1: RST, PCI reset active / not deactivated (red)
LED0: uEFI BIOS boot failure (red)



4.4.15 LED Control Register (LCTRL)

This register is used to switch on and off the General Purpose LEDs (LED 0..3).

Table 4-19: LED Control Register (LCTRL)

REGISTER NAME		LED CONTROL REGISTER (LCTRL)		
ADDRESS		0x291		
BIT	NAME	DESCRIPTION	RESET VALUE	ACCESS
7-4	LCMD	General Purpose LED command: 0000 = Get LED 0 0001 = Get LED 1 0010 = Get LED 2 0011 = Get LED 3 0100 - 0111 = Reserved 1000 = Set LED 0 1001 = Set LED 1 1010 = Set LED 2 1011 = Set LED 3 1100 - 1111 = Reserved	0000	R/W
3-0	LCOL	General Purpose LED color: 0000 = Off 0001 = Green 0010 = Red 0011 = Red+green 0100 - 1111 = Reserved	0000	R/W



Note ...

This register can only be used if the General Purpose LEDs indicated in the “LED Configuration Register” (Table 4-18) are configured in Mode A.





4.4.16 General Purpose Output Register (GPOUT)

This register is used to control the general purpose output signals on the rear I/O CPCI connectors.

Table 4-20: General Purpose Output Register (GPOUT)

REGISTER NAME		GENERAL PURPOSE OUTPUT REGISTER (GPOUT)		
ADDRESS		0x292		
BIT	NAME	DESCRIPTION	RESET VALUE	ACCESS
7-4	Res.	Reserved	0000	R
3	GPO3	General Purpose Output 3: 0 = Output low 1 = Output high	0	R/W
2	GPO2	General Purpose Output 2: 0 = Output low 1 = Output high	0	R/W
1	GPO1	General Purpose Output 1: 0 = Output low 1 = Output high	0	R/W
0	GPO0	General Purpose Output 0: 0 = Output low 1 = Output high	0	R/W

4.4.17 General Purpose Input Register (GPIN)

This register is used to control the general purpose input signals on the rear I/O CPCI connectors.

Table 4-21: General Purpose Input Register (GPIN)

REGISTER NAME		GENERAL PURPOSE INPUT REGISTER (GPIN)		
ADDRESS		0x293		
BIT	NAME	DESCRIPTION	RESET VALUE	ACCESS
7-4	Res.	Reserved	0000	R
3	GPI3	General Purpose Input 3: 0 = Input low 1 = Input high	1	R
2	GPI2	General Purpose Input 2: 0 = Input low 1 = Input high	1	R
1	GPI1	General Purpose Input 1: 0 = Input low 1 = Input high	1	R
0	GPI0	General Purpose Input 0: 0 = Input low 1 = Input high	1	R

4.4.18 IPMI Keyboard Controller Style Interface

The host processor communicates with the IPMI controller using one Keyboard Controller Style (KCS) interface, which is defined in the IPMI specification. The KCS interface is on the I/O location 0xCA2 and 0xCA3, and configured as regular ISA interrupt.



This page has been intentionally left blank.





Chapter

5

Power Considerations



This page has been intentionally left blank.





5. Power Considerations

5.1 System Power

The considerations presented in the ensuing chapters must be taken into account by system integrators when specifying the CP6004-SA system environment.

5.1.1 CP6004-SA Baseboard

The CP6004-SA baseboard itself has been designed for optimal power input and distribution. Still it is necessary to observe certain criteria essential for application stability and reliability.

The table below indicates the absolute maximum input voltage ratings that must not be exceeded. Power supplies to be used with the CP6004-SA should be carefully tested to ensure compliance with these ratings.

Table 5-1: Maximum Input Power Voltage Limits

SUPPLY VOLTAGE	MAXIMUM PERMITTED VOLTAGE
+3.3 V	+3.6 V
+5 V	+5.5 V
+12 V	+14.0 V
-12 V	-14.0 V



Warning!

The maximum permitted voltage indicated in the table above must not be exceeded. Failure to comply with the above may result in damage to your board.

The following table specifies the ranges for the different input power voltages within which the board is functional. The CP6004-SA is not guaranteed to function if the board is not operated within the prescribed limits.

Table 5-2: DC Operational Input Voltage Ranges

INPUT SUPPLY VOLTAGE	ABSOLUTE RANGE	RECOMMENDED RANGE
+3.3 V	3.2 V min. to 3.47 V max.	3.3 V min. to 3.47 V max.
+5 V	4.85 V min. to 5.25 V max.	5.0 V min. to 5.25 V max.
+12 V	11.4 V min. to 12.6 V max.	12 V min. to 12.6 V max.
-12 V	-11.4 V min. to -12.6 V max.	Only for PMC/XMC



5.1.2 Backplane

Backplanes to be used with the CP6004-SA must be adequately specified. The backplane must provide optimal power distribution for the +3.3 V, +5 V and +12 V power inputs.

Input power connections to the backplane itself should be carefully specified to ensure a minimum of power loss and to guarantee operational stability. Long input lines, under-dimensioned cabling or bridges, high resistance connections, etc. must be avoided. It is recommended to use POSITRONIC or M-type connector backplanes and power supplies where possible.

5.1.3 Power Supply Units

Power supplies for the CP6004-SA must be specified with enough reserve for the remaining system consumption. In order to guarantee a stable functionality of the system, it is recommended to provide more power than the system requires. An industrial power supply unit should be able to provide at least twice as much power as the entire system requires.

As the design of the CP6004-SA has been optimized for minimal power consumption, the power supply unit shall be stable even without minimum load.

Where possible, power supplies which support voltage sensing should be used. Depending on the system configuration this may require an appropriate backplane. The power supply should be sufficient to allow for backplane input line resistance variations due to temperature changes, etc.

5.1.3.1 Start-Up Requirement

Power supplies must comply with the following guidelines, in order to be used with the CP6004-SA:

- Beginning at 10% of the nominal output voltage, the voltage must rise within > 0.1 ms to < 20 ms to the specified regulation range of the voltage. Typically: > 5 ms to < 15 ms.
- There must be a smooth and continuous ramp of each DC output voltage from 10% to 90% of the regulation band.
- The slope of the turn-on waveform shall be a positive, almost linear voltage increase and have a value from 0 V to nominal V_{out} .

5.1.3.2 Power-Up Sequence

The +5 VDC output level must always be equal to or higher than the +3.3 VDC output during power-up and normal operation.

Both voltages must reach their minimum in-regulation level not later than 20 ms after the output power ramp start.



5.1.3.3 Tolerance

The tolerance of the voltage lines is described in the CompactPCI specification (PICMG 2.0 R3.0). The recommended measurement point for the voltage is the CompactPCI connector on the CPU board.

The following table provides information regarding the required characteristics for each board input voltage.

Table 5-3: Input Voltage Characteristics

VOLTAGE	NOMINAL VALUE	TOLERANCE	MAX. RIPPLE (p-p)	REMARKS
5 V	+5.0 VDC	+5%/-3%	50 mV	Main voltage
3.3 V	+3.3 VDC	+5%/-3%	50 mV	-
+12 V	+12 VDC	+5%/-5%	240 mV	Required
-12 V	-12 VDC	+5%/-5%	240 mV	Not required
V/I/O (PCI) voltage	+3.3 VDC or +5 VDC	+5%/-3%	50 mV	-
GND	Ground, not directly connected to potential earth (PE)			

The output voltage overshoot generated during the application (load changes) or during the removal of the input voltage must be less than 5% of the nominal value. No voltage of reverse polarity may be present on any output during turn-on or turn-off.

5.1.3.4 Regulation

The power supply shall be unconditionally stable under line, load, unload and transient load conditions including capacitive loads. The operation of the power supply must be consistent even without the minimum load on all output lines.



Warning!

All of the input voltages must be functionally coupled to each other so that if one input voltage fails, all other input voltages must be regulated proportionately to the failed voltage. For example, if the +5V begins to decrease, all other input voltages must decrease accordingly. This is required in order to preclude cross currents within the CP6004-SA.

Failure to comply with above may result in damage to the board or improper system operation.



Note ...

If the main power input is switched off, the supply voltages will not go to 0V instantly. It will take a couple of seconds until the capacitors are discharged. If the voltage rises again before it has gone below a certain level, the circuits may enter a latch-up state where even a hard RESET will not help any more. The system must be switched off for at least 10 seconds before it may be switched on again. If problems still occur, turn off the main power for 30 seconds before turning it on again.



5.2 Power Consumption

The goal of this description is to provide a method to calculate the power consumption for the CP6004-SA baseboard and for additional configurations. The processor and the memory dissipates the majority of the thermal power.

The power consumption measurements were carried out using the following testing parameters:

- board installed in an 8-slot passive CompactPCI backplane with two power supplies, one for the CPU, and the other for the hard disk
- board installed in the system slot
- Ethernet ports not connected
- 3.3 V and 5 V supply voltage
- 2.5 m/s airflow

The operating systems used were uEFI shell and Windows® 7, 64-bit. All measurements were conducted at a temperature of 25°C. The measured values varied because the power consumption was dependent on the processor activity.



Note ...

The power consumption values indicated in the tables below can vary depending on the ambient temperature or the system performance. This can result in deviations of the power consumption values of up to 15%.

The payload power consumption was measured using the following the 3rd generation processors:

- Intel® Core™ i7-3615QE (SV) quad-core processor, 2.3 GHz, 6 MB L3 cache
- Intel® Core™ i7-3612QE (SV) quad-core processor, 2.1 GHz, 6 MB L3 cache
- Intel® Core™ i5-3610ME (SV) dual-core processor, 2.7 GHz, 3 MB L3 cache
- Intel® Core™ i7-3555LE (LV) dual-core processor, 2.5 GHz, 4 MB L3 cache

with the following firmware and under the following testing conditions:

- CP6004-SA in uEFI shell mode
For this measurement the processor cores were active (no power management enabled), the graphics controller was in idle state (no application running) and Intel® Turbo Boost Technology was enabled.
- CP6004-SA with Windows® 7, 64-bit, processor and graphics controller in idle state
For this measurement all processor cores and the graphics controller were in idle state (no application running), and Intel® Turbo Boost Technology and the processor C3 and C6 states were enabled.
- CP6004-SA with Windows® 7, 64-bit, maximum processor workload with basic graphics operation
For this measurement all processor cores were operating at maximum workload and the graphics controller was performing basic operation (e.g. dual screen output configuration with no 3D graphics application running) while Intel® Turbo Boost Technology was disabled. These values represent the power dissipation reached under realistic, OS-controlled applications with the processor operating at maximum performance.
- CP6004-SA with Win.® 7, 64-bit, maximum processor and graphics controller workload
These values represent the maximum power dissipation achieved through the use of specific tools to heat up the processor and the graphics controller. For this measurement Intel® Turbo Boost Technology was enabled. These values are unlikely to be reached in real applications.

The following tables indicate the typical power consumption of the CP6004-SA with 4 GB DDR3 SDRAM in dual-channel mode. The measurements were made with the CP6004-SA in uEFI shell mode as well as with the Windows® 7 operating system, 64-bit.

Table 5-4: CP6004-SA in uEFI Shell Mode

NOMINAL VOLTAGE	Core™ i7-3615QE (SV) 2.3 GHz	Core™ i7-3612QE (SV) 2.1 GHz	Core™ i5-3610ME (SV) 2.7 GHz	Core™ i7-3555LE (LV) 2.5 GHz
+12 V	0.1 W	0.1 W	0.1 W	0.1 W
5 V	7.0 W	7.0 W	6.0 W	6.0 W
3.3 V	10.0 W	10.0 W	10.0 W	10.0 W
Total	17.1 W	17.1 W	16.1 W	16.1 W

Table 5-5: CP6004-SA with Win. 7 and Processor and Graphics in Idle State

NOMINAL VOLTAGE	Core™ i7-3615QE (SV) 2.3 GHz	Core™ i7-3612QE (SV) 2.1 GHz	Core™ i5-3610ME (SV) 2.7 GHz	Core™ i7-3555LE (LV) 2.5 GHz
+12 V	0.1 W	0.1 W	0.1 W	0.1 W
5 V	6.1 W	5.1 W	2.8 W	2.6 W
3.3 V	10.0 W	10.0 W	10.0 W	10.0 W
Total	16.2 W	15.2 W	12.9 W	12.7 W

Table 5-6: CP6004-SA with Win. 7 and Max. Proc. Workload and Basic Graphics Oper.

NOMINAL VOLTAGE	Core™ i7-3615QE (SV) 2.3 GHz	Core™ i7-3612QE (SV) 2.1 GHz	Core™ i5-3610ME (SV) 2.7 GHz	Core™ i7-3555LE (LV) 2.5 GHz
+12 V	0.1 W	0.1 W	0.1 W	0.1 W
5 V	29.0 W	22.0 W	19.0 W	14.0 W
3.3 V	12.0 W	12.0 W	12.0 W	12.0 W
Total	41.1 W	34.1 W	31.1 W	26.1 W

Table 5-7: CP6004-SA with Win. 7 and Max. Processor and Graphics Workload

NOMINAL VOLTAGE	Core™ i7-3615QE (SV) 2.3 GHz	Core™ i7-3612QE (SV) 2.1 GHz	Core™ i5-3610ME (SV) 2.7 GHz	Core™ i7-3555LE (LV) 2.5 GHz
+12 V	0.1 W	0.1 W	0.1 W	0.1 W
5 V	45.0 W	33.0 W	33.0 W	24.0 W
3.3 V	18.0 W	18.0 W	18.0 W	18.0 W
Total	63.1 W	51.1 W	51.1 W	42.1 W



5.2.1 Power Consumption of the CP6004-SA Accessories

The following table indicates the power consumption of the CP6004-SA accessories.

Table 5-8: Power Consumption of CP6004-SA Accessories

MODULE	POWER 5 V	POWER 3.3 V
DDR3 SDRAM update from 4 GB to 8 GB	—	approx. 1.0 W
DDR3 SDRAM update from 4 GB to 16 GB	—	approx. 2.0 W
SATA Flash module	—	approx. 1.0 W

5.2.2 Power Consumption per Gigabit Ethernet Port

The following table indicates the power consumption per Gigabit Ethernet port.

Table 5-9: Power Consumption per Gigabit Ethernet Port

POWER CONSUMPTION	POWER 5 V	POWER 3.3 V
One 1000 Mb/s Ethernet port connected	—	approx. 0.5 W

5.3 Maximum Power Consumption of PMC Module

A maximum power of 7.5 W is available on the PMC slot. This is in accordance with the draft standard P1386/Draft 2.4a. The maximum power of 7.5 W can be arbitrarily divided on the 3.3 V and 5 V voltage lines.

The following table indicates the current of a PMC module.

Table 5-10: PMC Module Current

VOLTAGE	CONTINUOUS CURRENT	PEAK CURRENT
3.3 V	2.27 A	3.0 A
5 V	1.5 A	2.0 A
+12 V	0.6 A	0.8 A
-12 V	0.4 A	0.4 A





5.4 Maximum Power Consumption of XMC Modules

A maximum power of 20 W is available on the XMC slot and it can be arbitrarily divided on the 3.3 V and 5 V (VPWR) voltage lines. XMC modules are based on 3.3 V power along with variable power (VPWR) defined as either 5 V or 12 V in the ANSI/VITA 42.0-200x XMC Switched Mezzanine Card Auxiliary Standard specification. On the CP6004-SA, the VPWR is configured to 5 V.

The following table indicates the current of an XMC module.

Table 5-11: XMC Module Current

VOLTAGE	CONTINUOUS CURRENT	PEAK CURRENT
3.3 V	1.0 A	1.25 A
5 V (VPWR)	3.0 A	3.5 A
+12 V	0.6 A	0.8 A
-12 V	0.4 A	0.4 A



Note ...

XMC integrators should carefully review the power ratings, cooling capacity and airflow requirements in the application prior to installation of an XMC module on the CP6004-SA.



This page has been intentionally left blank.





Chapter

6

Thermal Considerations



This page has been intentionally left blank.





6. Thermal Considerations

The following chapters provide system integrators with the necessary information to satisfy thermal and airflow requirements when implementing CP6004-SA applications.

6.1 Board Internal Thermal Monitoring

To ensure optimal operation and long-term reliability of the CP6004-SA, all onboard components must remain within the maximum temperature specifications. The most critical components on the CP6004-SA are the processor and the chipset. Operating the CP6004-SA above the maximum operating limits will result in permanent damage to the board. To ensure functionality at the maximum temperature, the IPMI controller supports several temperature monitoring and control features.

The CP6004-SA includes several temperature sensors to measure the onboard temperature values:

- Thermal sensors integrated in the processor
- Thermal sensor integrated in the chipset
- Onboard temperature sensor Temp1 (see Figure 1-6 for its placement)

The onboard temperature sensor Temp1 is accessible via the IPMI controller. For information on the temperature sensors integrated in the CPU and the chipset, refer to Chapter 6-2 and Chapter 6-3.

6.2 Processor Thermal Monitoring

To allow optimal operation and long-term reliability of the CP6004-SA, the 3rd generation Intel® Core™ i7/i5 processor must remain within the maximum die temperature specifications. The maximum operating temperature for the processor die is 105°C.

The 3rd generation Intel® Core™ i7/i5 processor uses the Adaptive Thermal Monitor feature to protect the processor from overheating and includes the following on-die temperature sensors:

- One Digital Thermal Sensor (DTS) for monitoring each processor core
- One Digital Thermal Sensor (DTS) for monitoring the graphics core
- One Digital Thermal Sensor (DTS) for monitoring the die temperature
- Catastrophic Cooling Failure Sensor (THERMTRIP#)

These sensors are integrated in the processor and work without any interoperability of the IPMI Controller, the uEFI BIOS or the software application. Thermal Control Circuit allows the processor to maintain a safe operating temperature without the need for special software drivers or interrupt handling routines.

6.2.1 Digital Thermal Sensor (DTS)

The 3rd generation Intel® Core™ i7/i5 processor includes up to six on-die Digital Thermal Sensors (DTS), up to four for the processor cores, one for the graphics core and one for the package die. They can be read via an internal register of the processor. The temperature returned by the Digital Thermal Sensor will always be at or below the maximum operating temperature (105°C). Via the Digital Thermal Sensors, the uEFI BIOS, the IPMI controller or the application software can measure the processor die temperature.



6.2.2 Adaptive Thermal Monitor

The Adaptive Thermal Monitor feature reduces the processor power consumption and the temperature when the processor silicon exceeds its maximum operating temperature until the processor operates at or below its maximum operating temperature.

The processor core power reduction is achieved by:

- Frequency/sVID Control (by reducing of processor core voltage)
- Clock Modulation (by turning the internal processor core clocks off and on)

Adaptive Thermal Monitor dynamically selects the appropriate method. uEFI BIOS is not required to select a specific method as with previous-generation processors supporting Intel® Thermal Monitor 1 (TM1) and Intel® Thermal Monitor 2 (TM2).

The Adaptive Thermal Monitor does not require any additional hardware, software drivers, or interrupt handling routines.

6.2.2.1 Frequency/sVID Control

Frequency/sVID Control reduces the processor's operating frequency (using the core ratio multiplier) and the input voltage (using serial VID signals). This combination of lower frequency and VID results in a reduction of the processor power consumption.

When the processor temperature reaches the TCC activation point, the event is reported via an external signal to the IPMI controller.

Running the processor at the lower frequency and voltage will reduce power consumption and should allow the processor to cool off. If the processor temperature does not drop below its maximum operating temperature, a second frequency and voltage transition will take place. This sequence of temperature checking and Frequency/sVID reduction will continue until either the minimum frequency has been reached or the processor temperature has dropped below its maximum operating temperature. If the processor temperature remains above its maximum operating temperature even after the minimum frequency has been reached, then Clock Modulation at that minimum frequency will be initiated.



Note ...

When the TH LED on the front panel is lit red after boot-up, it indicates that the processor die temperature is above 105°C.

6.2.2.2 Clock Modulation

Clock Modulation reduces power consumption by rapidly turning the internal processor core clocks off and on at a duty cycle that should reduce power dissipation (typically a 30-50% duty cycle).

Once the temperature has dropped below the maximum operating temperature, the TCC goes inactive and clock modulation ceases.



Note ...

When the TH LED on the front panel is lit red after boot-up, it indicates that the processor die temperature is above 105°C.



6.2.3 Catastrophic Cooling Failure Sensor

The Catastrophic Cooling Failure Sensor protects the processor from catastrophic overheating. The Catastrophic Cooling Failure Sensor threshold is set well above the normal operating temperature to ensure that there are no false trips. The processor will stop all executions when the junction temperature exceeds approximately 125°C. Once activated, the event remains latched until the CP6004-SA undergoes a power-on restart (all power off and then on again).

This function cannot be enabled or disabled in the uEFI BIOS. It is always enabled to ensure that the processor is protected in any event.



Note ...

When the TH LED on the front panel is blinking red, it indicates that the processor temperature is above 125°C.

6.3 Chipset Thermal Monitor Feature

The Intel® QM77 Chipset includes one on-die Thermal Diode Sensor to measure the chipset die temperature.

The maximum Intel® QM77 Chipset junction temperature is 108°C.

6.4 External Thermal Regulation

To ensure the best possible basis for operational stability and long-term reliability, the CP6004-SA is equipped with a heat sink. Coupled together with system chassis, which provides variable configurations for forced airflow, controlled active thermal energy dissipation is guaranteed. The physical size, shape, and construction of the heat sink and ensures the lowest possible thermal resistance. In addition, the CP6004-SA has been specifically designed to efficiently support forced airflow as found in modern CompactPCI systems.

Thermal Characteristic Graphs

The thermal characteristic graphs shown in the following sections illustrate the maximum ambient air temperature as a function of the volumetric airflow rate for the power consumption indicated. The diagrams are intended to serve as guidance for reconciling board and system with the required computing power considering the thermal aspect. One diagram per CPU version is provided. There are up to two curves representing upper level working points based on different levels of average CPU utilization. When operating below the corresponding curve, the CPU runs steadily without any intervention of thermal supervision. When operated above the corresponding curve, various thermal protection mechanisms may take effect resulting in temporarily reduced CPU performance or finally in an emergency stop in order to protect the CPU and the chipset from thermal destruction. In real applications this means that the board can be operated temporarily at a higher ambient temperature or at a reduced flow rate and still provide some margin for temporarily requested peak performance before thermal protection will be activated.

An airflow of 2.0 m/s to 3.0 m/s is a typical value for a standard *Kontron* ASM rack. For other racks or housings the available airflow will differ. The maximum ambient operating temperature must be recalculated and/or measured for such environments. For the calculation of the maximum ambient operating temperature, the processor and chipset junction temperature must never exceed the specified limit for the involved processor and chipset.



Thermal characteristic curves

- Thermal characteristic curve of the CP6004-SA with maximum processor workload and basic graphics operation
This load complies with the values indicated in Chapter 5.2, “Power Consumption of the CP6004-SA”, Table 5-6.
- Thermal characteristic curve of the CP6004-SA with maximum processor and graphics controller workload
This load complies with the values indicated in Chapter 5.2, “Power Consumption of the CP6004-SA”, Table 5-7.

How to read the diagram

Select a specific CPU and choose a specific working point. For a given flow rate there is a maximum airflow input temperature (= ambient temperature) provided. Below this operating point, thermal supervision will not be activated. Above this operating point, thermal supervision will become active protecting the CPU from thermal destruction. The minimum airflow rate provided must be more than the value specified in the diagram.

Volumetric flow rate

The volumetric flow rate refers to an airflow through a fixed cross-sectional area (i.e. slot width x depth). The volumetric flow rate is specified in m³/h (cubic-meter-per-hour) or cfm (cubic-feet-per-minute) respectively.

Conversion: 1 cfm = 1.7 m³/h; 1 m³/h = 0.59 cfm

Airflow

At a given cross-sectional area and a required flow rate, an average, homogeneous airflow speed can be calculated using the following formula:

Airflow = Volumetric flow rate / area.

The airflow is specified in m/s (meter-per-second) or in fps (feet-per-second) respectively.

Conversion: 1 fps = 0.3048 m/s; 1 m/s = 3.28 fps

The following figures illustrate the operational limits of the CP6004-SA taking into consideration power consumption vs. ambient air temperature vs. airflow rate. The measurements were made based on a 4HP slot and with both processor cores enabled.



6.4.1 Operational Limits for the CP6004-SA

Figure 6-1: CP6004-SA with Core™ i7-3615QE (SV) 2.3 GHz

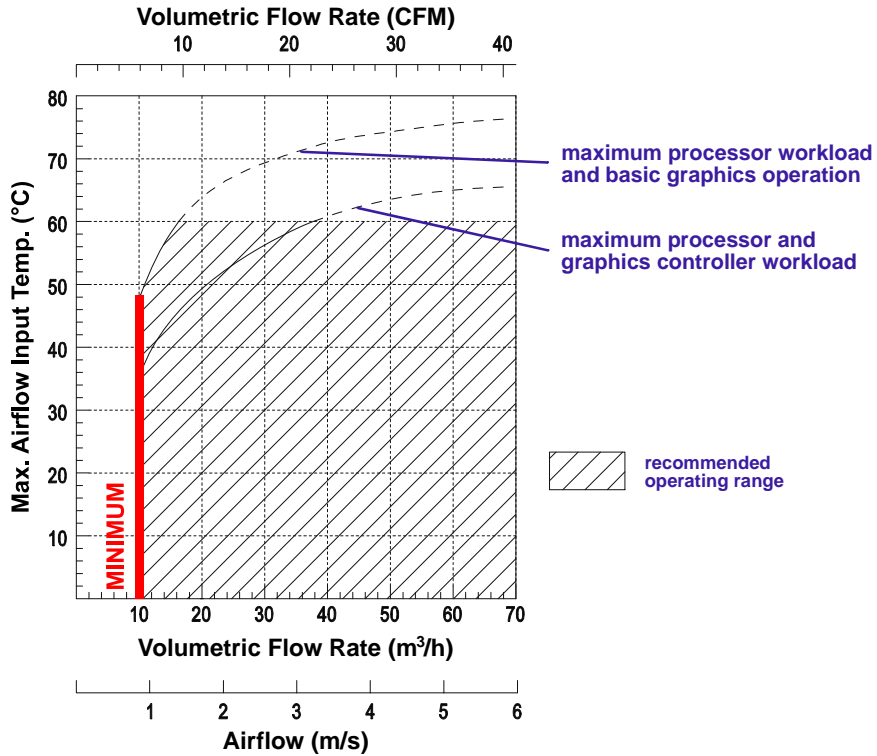

Figure 6-2: CP6004-SA with Core™ i7-3612QE (SV) 2.1 GHz

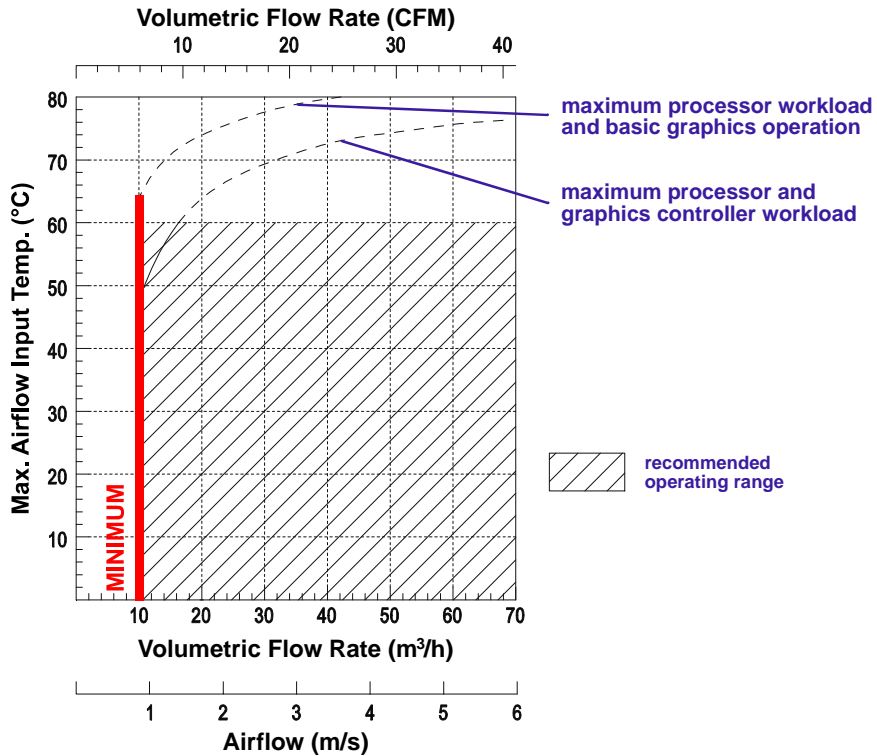



Figure 6-3: CP6004-SA with Core™ i7-3555LE (LV) 2.5 GHz

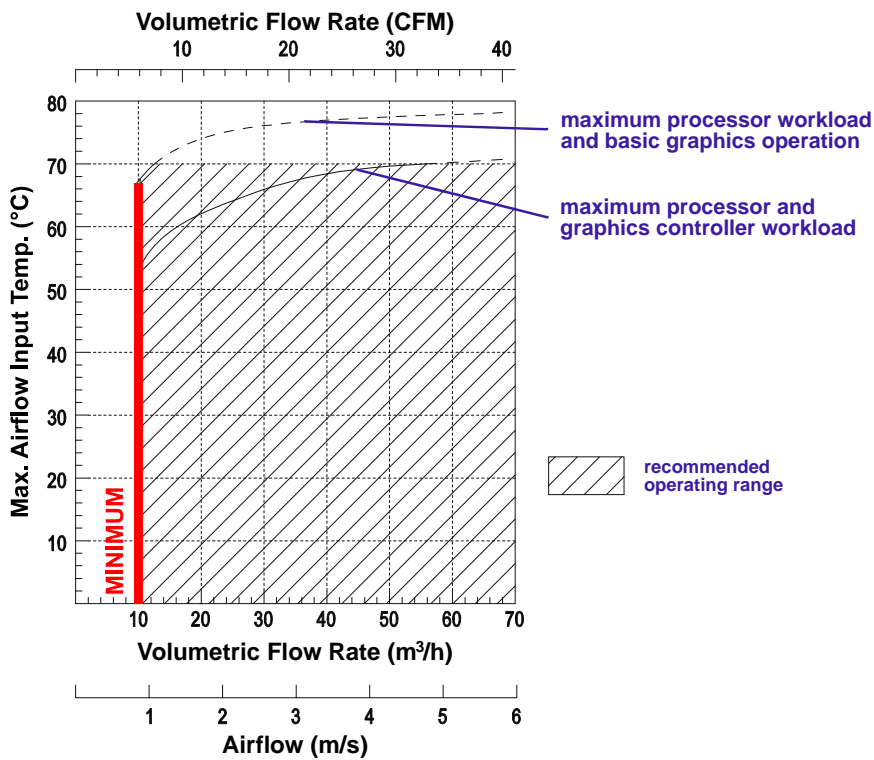
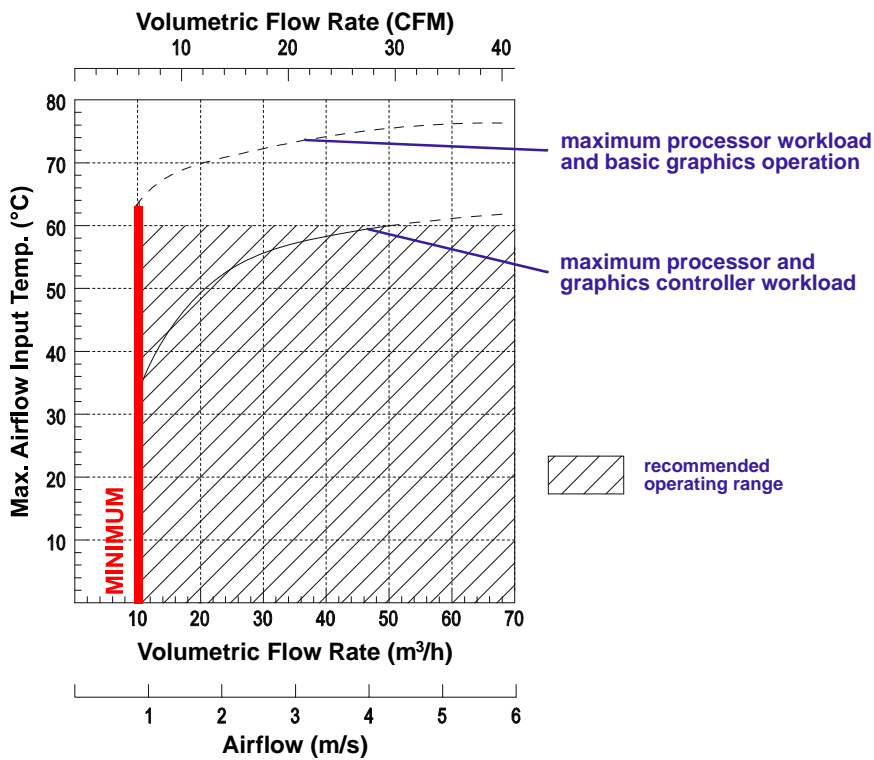

Figure 6-4: CP6004-SA with Core™ i5-3610ME (SV) 2.7 GHz





6.4.2 Peripherals

When determining the thermal requirements for a given application, peripherals to be used with the CP6004-SA must also be considered. Devices such as HDDs, SSDs, PMC modules, XMC modules, and SATA Flash modules which are directly attached to the CP6004-SA must also be capable of being operated at the temperatures foreseen for the application. It may very well be necessary to revise system requirements to comply with operational environment conditions. In most cases, this will lead to a reduction in the maximum allowable ambient operating temperature or even require active cooling of the operating environment.



Warning!

As Kontron assumes no responsibility for any damage to the CP6004-SA or other equipment resulting from overheating of the CPU, it is highly recommended that system integrators as well as end users confirm that the operational environment of the CP6004-SA complies with the thermal considerations set forth in this document.



This page has been intentionally left blank.





Appendix



CP6004-SA-MK2.5SATA



This page has been intentionally left blank.





A. CP6004-SA-MK2.5-SATA Assembly Kit

The optional CP6004-SA-MK2.5-SATA assembly kit includes the MMADP-SATA01 module and the necessary components required for mounting the 2.5" SATA HDD/SSD on the CP6004-SA.

A.1 MMADP-SATA01 Module Overview

The MMADP-SATA01 module has been designed for use with the Kontron CP6004-SA board and enables the user to connect an onboard 2.5" SATA HDD/SSD to the CP6004-SA.

A.2 Technical Specifications

Table A-1: MMADP-SATA01 Main Specifications

MMADP-SATA01		SPECIFICATIONS
Interfaces	Board-to-Board Connectors	One 34-pin, male, board-to-board connector, J1
	SATA Connector	One 22-pin SATA connector, J2
General	Power Supply for SATA devices	3.3 V and 5 V (12 V not available)
	Temperature Range	Operational: 0°C to +60°C Standard -40°C to +70°C Extended Storage: -40°C to +85°C
	Climatic Humidity	93% RH at 40°C, non-condensing (acc. to IEC 60068-2-78)
	Board Weight	ca. 5 grams (without HDD/SSD)



A.3 MMADP-SATA01 Module Layout

The MMADP-SATA01 module includes one board-to-board connector, J1, for connection to the CP6004-SA board and one SATA connector, J2, for connection to an onboard 2.5" HDD/SSD device.

Figure A-1: MMADP-SATA01 Module Layout

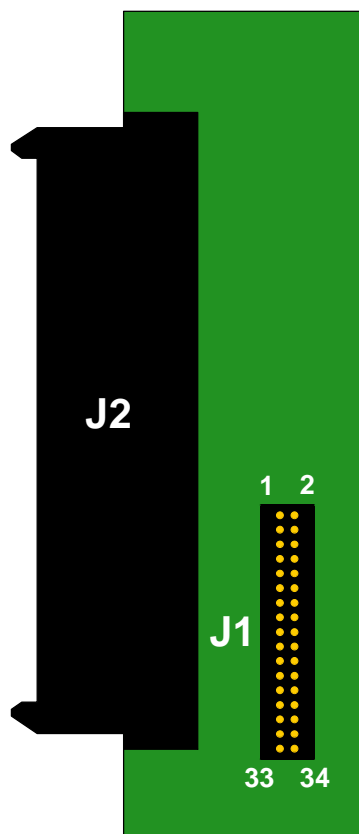

A.4 SATA Connector J2

The SATA connector, J2, on the MMADP-SATA01 module is connected to the 2.5" SATA HDD/SSD mounted on the CP6004-SA. The SATA connector is divided into two segments, a signal segment and a power segment.

Figure A-2: SATA Connector J2

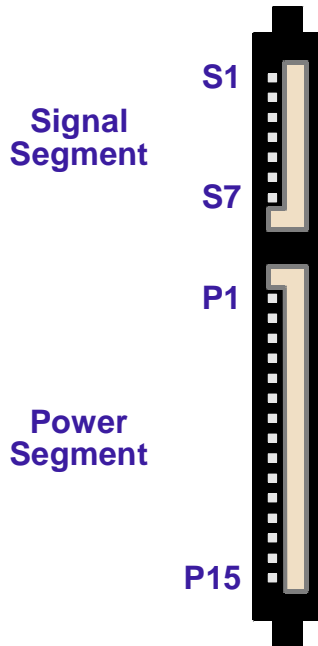
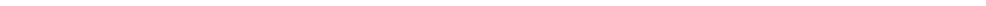

Table A-2: SATA Connector J2 Pinout

PIN	SIGNAL	FUNCTION	I/O
Signal Segment Key			
S1	GND	Ground signal	--
S2	SATA_TX+	Differential Transmit+	O
S3	SATA_TX-	Differential Transmit-	O
S4	GND	Ground signal	--
S5	SATA_RX-	Differential Receive-	I
S6	SATA_RX+	Differential Receive+	I
S7	GND	Ground signal	--
Signal Segment "L"			
Central Connector Polarizer			
Power Segment "L"			
P1	3.3V	3.3V power	--
P2	3.3V	3.3V power	--
P3	3.3V	3.3V power	--
P4	GND	Ground signal	--
P5	GND	Ground signal	--
P6	GND	Ground signal	--
P7	5V	5V power	--
P8	5V	5V power	--
P9	5V	5V power	--
P10	GND	Ground signal	--
P11	RES	Reserved	--
P12	GND	Ground signal	--
P13	12V (NC)	Not connected	--
P14	12V (NC)	Not connected	--
P15	12V (NC)	Not connected	--
Power Segment Key			



This page has been intentionally left blank.





Appendix

B

SATA Flash Module



This page has been intentionally left blank.





B. SATA Flash Module

The CP6004-SA provides an optional SATA Flash module with up to 64 GB NAND flash memory. The SATA Flash module is connected to the CP6004-SA via the board-to-board connectors J17 located on the CP6004-SA and J2 located on the SATA Flash module. The SATA Flash module has been optimized for embedded systems providing high performance, reliability and security.

B.1 Technical Specifications

Table B-1: SATA Flash Module Main Specifications

SATA FLASH MODULE		SPECIFICATIONS
Interface	Board-to-Board Connector	One 34-pin, male, board-to-board connector, J2
Memory	Memory	Up to 64 GB SLC-based NAND flash memory <ul style="list-style-type: none"> • Built-in full hard disk emulation • Up to 100 MB/s read rate • Up to 90 MB/s write rate
General	Power Consumption	typ. 1.0 W 3.3 V supply
	Temperature Range	Operational: 0°C to +60°C Standard -40°C to +70°C Extended (on request) Storage: -40°C to +85°C
	Climatic Humidity	93% RH at 40°C, non-condensing (acc. to IEC 60068-2-78)
	Dimensions	70 mm x 28 mm
	Board Weight	ca. 14 grams



Note ...

Write protection is available for this module. Contact Kontron for further assistance if write protection is required.



B.2 SATA Flash Module Layout

The SATA Flash module includes one board-to-board connector, J2, for connection to the CP6004-SA.

Figure B-1: SATA Flash Module Layout (Bottom View)

