

» User Guide «

CP6012

**6U CompactPCI Processor Board based on
the Intel® Core™ Duo Processor and
the Intel® Core™ 2 Duo Processor with
the Intel® E7520 Chipset**

Doc. ID: 33274, Rev. 5.0
September 18, 2009



Revision History

Publication Title:		CP6012: 6U CompactPCI Processor Board based on the Intel® Core™ Duo Processor and the Intel® Core™ 2 Duo Processor with the Intel® E7520 Chipset
Doc. ID:		33274
Rev.	Brief Description of Changes	Date of Issue
1.0	Initial issue	25-Aug-2006
2.0	General update	21-Dec-2006
3.0	General update, deletion of appendix C, AMIBIOS8	23-Aug-2007
4.0	General update; added new narrow heat sink as a replacement for the wide heat sink	27-Feb-2008
5.0	General update	18-Sep-2009

Imprint

Kontron Modular Computers GmbH may be contacted via the following:

MAILING ADDRESS

Kontron Modular Computers GmbH
Sudetenstraße 7
D - 87600 Kaufbeuren Germany

TELEPHONE AND E-MAIL

+49 (0) 800-SALESKONTRON
sales@kontron.com

For further information about other Kontron products, please visit our Internet web site: www.kontron.com.

Disclaimer

Copyright © 2009 Kontron AG. All rights reserved. All data is for information purposes only and not guaranteed for legal purposes. Information has been carefully checked and is believed to be accurate; however, no responsibility is assumed for inaccuracies. Kontron and the Kontron logo and all other trademarks or registered trademarks are the property of their respective owners and are recognized. Specifications are subject to change without notice.



Table of Contents

<i>Revision History</i>	<i>ii</i>
<i>Imprint</i>	<i>ii</i>
<i>Disclaimer</i>	<i>ii</i>
<i>Table of Contents</i>	<i>iii</i>
<i>List of Tables</i>	<i>ix</i>
<i>List of Figures</i>	<i>xiii</i>
<i>Proprietary Note</i>	<i>xv</i>
<i>Trademarks</i>	<i>xv</i>
<i>Environmental Protection Statement</i>	<i>xv</i>
<i>Explanation of Symbols</i>	<i>xvi</i>
<i>For Your Safety</i>	<i>xvii</i>
<i>High Voltage Safety Instructions</i>	<i>xvii</i>
<i>Special Handling and Unpacking Instructions</i>	<i>xvii</i>
<i>General Instructions on Usage</i>	<i>xviii</i>
<i>Two Year Warranty</i>	<i>xix</i>
1. Introduction	1 - 3
1.1 <i>Board Overview</i>	1 - 3
1.2 <i>Board-Specific Information</i>	1 - 4
1.3 <i>System Expansion Capabilities</i>	1 - 5
1.3.1 <i>PMC Modules</i>	1 - 5
1.3.2 <i>XMC Modules</i>	1 - 5
1.3.3 <i>CTM80-3 Rear I/O Module</i>	1 - 5
1.3.4 <i>CP6012-MK2.5SATA Assembly Kit</i>	1 - 5
1.4 <i>System Relevant Information</i>	1 - 6
1.5 <i>Board Diagrams</i>	1 - 7
1.5.1 <i>Functional Block Diagram</i>	1 - 7
1.5.2 <i>Front Panel</i>	1 - 8
1.5.3 <i>Board Layout</i>	1 - 9
1.6 <i>Technical Specification</i>	1 - 11
1.7 <i>Kontron Software Support</i>	1 - 17
1.8 <i>Standards</i>	1 - 17
1.9 <i>Related Publications</i>	1 - 18



2. Functional Description	2 - 3
2.1 CPU, Memory and Chipset	2 - 3
2.1.1 CPU	2 - 3
2.1.2 Memory	2 - 5
2.1.3 Intel® E7520 Chipset Overview	2 - 6
2.1.3.1 Memory Controller Hub E7520	2 - 6
2.1.3.2 I/O Controller Hub 6300ESB	2 - 6
2.2 Peripherals	2 - 7
2.2.1 Timer	2 - 7
2.2.2 Watchdog Timer	2 - 7
2.2.3 Battery	2 - 7
2.2.4 Reset	2 - 8
2.2.5 SMBus Devices	2 - 8
2.2.6 Thermal Management/System Monitoring	2 - 8
2.2.7 Serial EEPROM	2 - 9
2.2.8 FLASH Memory	2 - 9
2.2.8.1 BIOS FLASH (Firmware Hub)	2 - 9
2.2.8.2 CompactFlash	2 - 9
2.3 Board Interfaces	2 - 10
2.3.1 Front Panel LEDs	2 - 10
2.3.1.1 IPMI LEDs	2 - 10
2.3.1.2 Watchdog and Overtemperature LEDs	2 - 10
2.3.1.3 Front-I and Front-II General Purpose LEDs	2 - 11
2.3.1.4 Hot Swap LED	2 - 11
2.3.2 USB Interfaces	2 - 12
2.3.3 Graphics Controller	2 - 12
2.3.3.1 Video Resolution	2 - 13
2.3.3.2 CRT Interface and Connector J10	2 - 13
2.3.4 COM Ports	2 - 14
2.3.5 Floppy Drive Interface	2 - 14
2.3.6 Gigabit Ethernet	2 - 15
2.3.7 EIDE Interfaces	2 - 16
2.3.7.1 CompactFlash Socket	2 - 16
2.3.8 Extension Connector J12	2 - 18

2.3.9	<i>Keyboard/Mouse Interface</i>	2 - 18
2.3.10	<i>Serial ATA Interface</i>	2 - 19
2.3.11	<i>Serial ATA Connector J22</i>	2 - 19
2.3.12	<i>2.5" SATA HDD Extension Connectors J23</i>	2 - 20
2.3.13	<i>PMC Interface</i>	2 - 21
2.3.13.1	<i>PMC Connectors J25, J26, J27 and J28 Pinouts</i>	2 - 22
2.3.14	<i>XMC Interface</i>	2 - 24
2.3.15	<i>CompactPCI Interface</i>	2 - 25
2.3.15.1	<i>System Master Configuration</i>	2 - 25
2.3.15.2	<i>Peripheral Master Configuration (Passive Mode)</i>	2 - 25
2.3.15.3	<i>Packet Switching Backplane (PICMG 2.16)</i>	2 - 25
2.3.15.4	<i>Hot Swap Support</i>	2 - 25
2.3.15.5	<i>Power Ramping</i>	2 - 25
2.3.15.6	<i>Precharge</i>	2 - 25
2.3.15.7	<i>Handle Switch</i>	2 - 26
2.3.15.8	<i>ENUM# Interrupt</i>	2 - 26
2.3.15.9	<i>Hot Swap LED</i>	2 - 26
2.3.16	<i>CompactPCI Bus Connector</i>	2 - 27
2.3.16.1	<i>CompactPCI Connector Keying</i>	2 - 27
2.3.16.2	<i>CompactPCI Connectors J1 and J2 Pinouts</i>	2 - 28
2.3.16.3	<i>CompactPCI Rear I/O Connectors J3-J5 and Pinouts</i>	2 - 32
2.3.16.4	<i>Rear I/O Configuration</i>	2 - 36
2.4	<i>Intelligent Platform Management Interface</i>	2 - 37
2.4.1	<i>Technical Background of IPMI</i>	2 - 37
2.4.2	<i>IPMI Glossary</i>	2 - 38
2.4.3	<i>IPMI Implementation on the CP6012</i>	2 - 39
2.4.3.1	<i>Sensors Implemented on the CP6012</i>	2 - 40
2.4.4	<i>Data Repositories</i>	2 - 41
3.	<i>Installation</i>	3 - 3
3.1	<i>Safety Requirements</i>	3 - 3
3.2	<i>CP6012 Initial Installation Procedures</i>	3 - 4
3.3	<i>Standard Removal Procedures</i>	3 - 5



3.4	<i>Hot Swap Procedures</i>	3 - 5
3.4.1	<i>System Master Hot Swap</i>	3 - 5
3.4.2	<i>Peripheral Hot Swap Procedure</i>	3 - 6
3.5	<i>Installation of CP6012 Peripheral Devices</i>	3 - 7
3.5.1	<i>CompactFlash Installation</i>	3 - 7
3.5.2	<i>USB Device Installation</i>	3 - 7
3.5.3	<i>Rear I/O Device Installation</i>	3 - 8
3.5.4	<i>Battery Replacement</i>	3 - 8
3.5.5	<i>Hard Disk Installation</i>	3 - 8
3.6	<i>Software Installation</i>	3 - 9
4.	<i>Configuration</i>	4 - 3
4.1	<i>Jumper Description</i>	4 - 3
4.1.1	<i>Clearing BIOS CMOS Setup</i>	4 - 3
4.1.2	<i>Shorting Chassis GND (Shield) to Logic GND</i>	4 - 3
4.1.3	<i>BIOS Firmware Hub Flash Configuration</i>	4 - 4
4.1.4	<i>M66EN Configuration</i>	4 - 4
4.2	<i>Interrupts</i>	4 - 5
4.3	<i>Onboard PCI Interrupt Routing</i>	4 - 6
4.4	<i>Memory Map</i>	4 - 7
4.4.1	<i>Memory Map for the 1st Megabyte</i>	4 - 7
4.4.2	<i>I/O Address Map</i>	4 - 8
4.5	<i>CP6012-Specific Registers</i>	4 - 9
4.5.1	<i>BIOS Boot Order Control Register</i>	4 - 9
4.5.2	<i>Watchdog Timer Control Register</i>	4 - 10
4.5.3	<i>Geographic Addressing Register</i>	4 - 12
4.5.4	<i>Hardware and Logic Revision Index Register</i>	4 - 12
4.5.5	<i>CPCI Reset Status Register</i>	4 - 13
4.5.6	<i>I/O Status Register</i>	4 - 14
4.5.7	<i>I/O Configuration Register</i>	4 - 15
4.5.8	<i>Board ID Register</i>	4 - 16
4.5.9	<i>Board Interrupt Configuration Register</i>	4 - 17
4.5.10	<i>Hot Swap Status Register</i>	4 - 18

4.5.11	<i>Board-Specific LED Control Register</i>	4 - 19
4.5.12	<i>Delay Timer Control/Status Register</i>	4 - 20
4.6	<i>BMC-Specific Registers</i>	4 - 21
4.6.1	<i>BMC Configuration Register</i>	4 - 21
4.6.1.1	<i>BMC Interrupt Configuration Register</i>	4 - 22
4.6.2	<i>IPMI Keyboard Control Style Interface</i>	4 - 23
5.	<i>Power Considerations</i>	5 - 3
5.1	<i>System Power</i>	5 - 3
5.1.1	<i>CP6012 Baseboard</i>	5 - 3
5.1.2	<i>Backplane</i>	5 - 4
5.1.3	<i>Power Supply Units</i>	5 - 4
5.1.3.1	<i>Start-Up Requirement</i>	5 - 4
5.1.3.2	<i>Power-Up Sequence</i>	5 - 5
5.1.3.3	<i>Tolerance</i>	5 - 5
5.1.3.4	<i>Regulation</i>	5 - 6
5.1.3.5	<i>Rise Time Diagram</i>	5 - 6
5.2	<i>Power Consumption</i>	5 - 7
5.2.1	<i>Power Consumption of the CP6012 Accessories</i>	5 - 9
5.2.2	<i>Power Consumption of the Dual Gigabit Ethernet Controller</i>	5 - 9
5.3	<i>Start-Up Currents of the CP6012</i>	5 - 10
5.4	<i>Power Available for PMC Devices</i>	5 - 10
6.	<i>Thermal Considerations</i>	6 - 3
6.1	<i>Board Internal Thermal Regulation</i>	6 - 3
6.1.1	<i>CPU Internal Thermal Supervision</i>	6 - 3
6.1.2	<i>CPU Emergency Thermal Supervision (Thermtrip)</i>	6 - 4
6.2	<i>Thermal Management Recommendations</i>	6 - 4
6.3	<i>External Thermal Regulation</i>	6 - 5
6.3.1	<i>Heat Sink</i>	6 - 5
6.3.2	<i>Forced Airflow</i>	6 - 5
6.3.3	<i>Thermal Characteristic Graphs</i>	6 - 6
6.3.4	<i>Peripherals</i>	6 - 10



A. CTM80-3 RIO Module	A - 3
A.1 Introduction	A - 3
B. CP6012-MK2.5SATA Assembly Kit	B - 3
B.1 CP6012-EXT-SATA Module Overview	B - 3
B.2 Technical Specifications	B - 3
B.3 CP6012-EXT-SATA Functional Block Diagram	B - 3
B.4 CP6012-EXT-SATA Module Layout	B - 4
B.4.1 CP6012-EXT-SATA Module Layout	B - 4
B.5 Module Interfaces	B - 5
B.5.1 Board-to-Board Connectors J1 and J3	B - 5
B.5.2 SATA Connector J2	B - 6



List of Tables

1-1	<i>System Relevant Information</i>	1 - 6
1-2	<i>CP6012 Main Specifications</i>	1 - 11
1-3	<i>Standards</i>	1 - 17
1-4	<i>Additional Standards for Boards Ordered with Ruggedized Service</i>	1 - 18
1-5	<i>Related Publications</i>	1 - 18
2-1	<i>Processors Supported on the CP6012</i>	2 - 4
2-2	<i>Maximum Power Dissipation of Processors (CPU only)</i>	2 - 4
2-3	<i>CPU Frequency in the Various SpeedStep® Modes</i>	2 - 4
2-4	<i>Memory Options Utilizing SODIMM Sockets</i>	2 - 5
2-5	<i>SMBus Device Addresses</i>	2 - 8
2-6	<i>EEPROM Address Map</i>	2 - 9
2-7	<i>IPMI LEDs Function</i>	2 - 10
2-9	<i>Front-I and Front-II LEDs Function</i>	2 - 11
2-8	<i>Watchdog and Overtemperature LEDs Function</i>	2 - 11
2-10	<i>USB Connectors J7 and J8 Pinout</i>	2 - 12
2-11	<i>Partial List of Display Modes Supported</i>	2 - 13
2-12	<i>D-Sub CRT Connector J10 Pinout</i>	2 - 13
2-13	<i>Serial Port Con. J9 (COM1) Pinout</i>	2 - 14
2-14	<i>Pinouts of J6A/B Based on the Implementation</i>	2 - 15
2-15	<i>CompactFlash Connector J17 Pinout</i>	2 - 17
2-16	<i>Keyboard Connector J21 Pinout</i>	2 - 18
2-17	<i>SATA Connector J22 Pinout</i>	2 - 19
2-18	<i>SATA Extension Connector J23 Pinout</i>	2 - 20
2-19	<i>Onboard PCI Configuration</i>	2 - 21
2-20	<i>PMC Connectors J26 and J28 Pinouts</i>	2 - 22
2-21	<i>PMC Connectors J25 and J27 Pinouts</i>	2 - 23
2-22	<i>XMC Connector J15 Pinout</i>	2 - 24
2-23	<i>Coding Key Colors on J1</i>	2 - 27
2-24	<i>CompactPCI Bus Connector J1 System Slot Pinout</i>	2 - 28
2-25	<i>CompactPCI Bus Connector J1 Peripheral Slot Pinout</i>	2 - 29
2-26	<i>64-bit CompactPCI Bus Connector J2 System Slot Pinout</i>	2 - 30
2-27	<i>64-bit CompactPCI Bus Connector J2 Peripheral Slot Pinout</i>	2 - 31



2-28	<i>CompactPCI Rear I/O Connector J3 Pinout</i>	2 - 32
2-29	<i>CompactPCI Rear I/O Connector J3 Signals</i>	2 - 33
2-30	<i>CompactPCI Rear I/O Connector J4 Pinout</i>	2 - 34
2-32	<i>CompactPCI Rear I/O Connector J5 Signals</i>	2 - 35
2-31	<i>CompactPCI Rear I/O Connector J5 Pinout</i>	2 - 35
2-33	<i>Rear I/O Configuration</i>	2 - 36
2-34	<i>Processor and Chipset Supervision</i>	2 - 40
2-35	<i>CompactPCI Sensors</i>	2 - 40
2-36	<i>Onboard Power Supply Supervision</i>	2 - 40
2-37	<i>Reset Control</i>	2 - 40
2-38	<i>Onboard Voltage Sensors</i>	2 - 41
2-39	<i>Temperature Sensors</i>	2 - 41
2-40	<i>Fan Sense Sensors</i>	2 - 41
3-1	<i>ATA Channel Routing</i>	3 - 9
4-1	<i>Clearing BIOS CMOS Setup</i>	4 - 3
4-2	<i>BIOS Firmware Hub Flash Configuration</i>	4 - 4
4-3	<i>M66EN Configuration</i>	4 - 4
4-4	<i>Interrupt Setting</i>	4 - 5
4-5	<i>PCI Interrupt Routing</i>	4 - 6
4-6	<i>Memory Map for the 1st Megabyte</i>	4 - 7
4-7	<i>I/O Address Map</i>	4 - 8
4-8	<i>BIOS Boot Order Control Register</i>	4 - 9
4-9	<i>Watchdog Timer Control Register</i>	4 - 11
4-10	<i>Geographic Addressing Register</i>	4 - 12
4-11	<i>Hardware and Logic Revision Index Register</i>	4 - 12
4-12	<i>CPCI Reset Status Register</i>	4 - 13
4-13	<i>I/O Status Register</i>	4 - 14
4-14	<i>I/O Configuration Register</i>	4 - 15
4-15	<i>Board ID Register</i>	4 - 16
4-16	<i>Board Interrupt Configuration Register</i>	4 - 17
4-17	<i>Hot Swap Status Register</i>	4 - 18
4-18	<i>Board-Specific LED Control Register</i>	4 - 19
4-19	<i>Delay Timer Control/Status Register</i>	4 - 20
4-20	<i>BMC Configuration Register</i>	4 - 21



4-21	<i>COM Port Routing for the Firmware Update</i>	4 - 22
4-22	<i>BMC Interrupt Configuration Register</i>	4 - 22
5-1	<i>Maximum Input Power Voltage Limits</i>	5 - 3
5-2	<i>DC Operational Input Voltage Ranges</i>	5 - 3
5-3	<i>Input Voltage Characteristics</i>	5 - 5
5-4	<i>Power Consumption: CP6012 with DOS</i>	5 - 8
5-5	<i>Power Consumption: CP6012 with Linux/Win. XP in IDLE Mode</i>	5 - 8
5-6	<i>Power Consumption: CP6012's TDP at 75%</i>	5 - 8
5-7	<i>Power Consumption: CP6012's TDP at 100%</i>	5 - 8
5-8	<i>Power Consumption of CP6012 Accessories</i>	5 - 9
5-9	<i>Intel® 82571EB Dual Gigabit Ethernet Controller Power Supply</i>	5 - 9
5-10	<i>Start-Up Currents of the CP6012</i>	5 - 10
5-11	<i>Maximum Output Power Limits</i>	5 - 10
B-1	<i>CP6012-EXT-SATA Main Specifications</i>	B - 3
B-2	<i>Board-to-Board Connector J1 Pinout</i>	B - 5
B-3	<i>SATA Connector J2 Pinout</i>	B - 6



This page has been intentionally left blank.





List of Figures

1-1	<i>CP6012 Functional Block Diagram</i>	1 - 7
1-2	<i>CP6012 Front Panel</i>	1 - 8
1-3	<i>CP6012 Board Layout (Front View)</i>	1 - 9
1-4	<i>CP6012 Board Layout (Reverse View)</i>	1 - 10
2-1	<i>USB Connectors J7 and J8</i>	2 - 12
2-2	<i>D-Sub CRT Connector J10</i>	2 - 13
2-3	<i>Serial Port Connector J9 (COM1)</i>	2 - 14
2-4	<i>Dual Gigabit Ethernet Connector J6A/B</i>	2 - 15
2-5	<i>Extension Connector J12</i>	2 - 18
2-6	<i>Keyboard Connector J21</i>	2 - 18
2-7	<i>SATA Connector J22</i>	2 - 19
2-8	<i>SATA Extension Connector J23</i>	2 - 20
2-9	<i>Connecting an Onboard 2.5" SATA HDD to CP6012-EXT-SATA</i>	2 - 20
2-10	<i>PMC Connectors J25, J26, J27 and J28</i>	2 - 21
2-11	<i>CPCI Connectors J1-J5</i>	2 - 27
6-1	<i>Start-Up Ramp of the CP3-SVE180 AC Power Supply</i>	5 - 6
6-1	<i>Operating Limits: Core™ Duo 1.66 GHz, Narrow Heat Sink</i>	6 - 7
6-2	<i>Operating Limits: Core™ Duo 2.0 GHz, Wide Heat Sink</i>	6 - 7
6-3	<i>Operating Limits: Core™ 2 Duo 1.5 GHz, Narrow Heat Sink</i>	6 - 8
6-4	<i>Operating Limits: Core™ 2 Duo 2.16 GHz, Wide Heat Sink</i>	6 - 8
6-5	<i>Operating Limits: Core™ 2 Duo 2.16 GHz, Narrow Heat Sink</i>	6 - 9
6-6	<i>Operating Limits: Core™ Duo 2.0 GHz, Narrow Heat Sink</i>	6 - 9
A-1	<i>CTM80-3 RIO Module with SCSI Configuration</i>	A - 4
A-2	<i>CTM80-3 RIO Module with PATA or SATA Configuration</i>	A - 5
B-1	<i>CP6012-EXT-SATA Functional Block Diagram</i>	B - 3
B-2	<i>CP6012-EXT-SATA Module Layout</i>	B - 4
B-3	<i>SATA Connector J2</i>	B - 6



This page has been intentionally left blank.





Proprietary Note

This document contains information proprietary to Kontron. It may not be copied or transmitted by any means, disclosed to others, or stored in any retrieval system or media without the prior written consent of Kontron or one of its authorized agents.

The information contained in this document is, to the best of our knowledge, entirely correct. However, Kontron cannot accept liability for any inaccuracies or the consequences thereof, or for any liability arising from the use or application of any circuit, product, or example shown in this document.

Kontron reserves the right to change, modify, or improve this document or the product described herein, as seen fit by Kontron without further notice.

Trademarks

Kontron, the *PEP* logo and, if occurring in this manual, “CXM” are trademarks owned by Kontron, Kaufbeuren (Germany). In addition, this document may include names, company logos and trademarks, which are registered trademarks and, therefore, proprietary to their respective owners.

Environmental Protection Statement

This product has been manufactured to satisfy environmental protection requirements where possible. Many of the components used (structural parts, printed circuit boards, connectors, batteries, etc.) are capable of being recycled.

Final disposition of this product after its service life must be accomplished in accordance with applicable country, state, or local laws or regulations.



Explanation of Symbols



Caution, Electric Shock!

This symbol and title warn of hazards due to electrical shocks (> 60V) when touching products or parts of them. Failure to observe the precautions indicated and/or prescribed by the law may endanger your life/health and/or result in damage to your material.

Please refer also to the section “High Voltage Safety Instructions” on the following page.



Warning, ESD Sensitive Device!

This symbol and title inform that electronic boards and their components are sensitive to static electricity. Therefore, care must be taken during all handling operations and inspections of this product, in order to ensure product integrity at all times.

Please read also the section “Special Handling and Unpacking Instructions” on the following page.



Warning!

This symbol and title emphasize points which, if not fully understood and taken into consideration by the reader, may endanger your health and/or result in damage to your material.



Note ...

This symbol and title emphasize aspects the reader should read through carefully for his or her own advantage.



For Your Safety

Your new Kontron product was developed and tested carefully to provide all features necessary to ensure its compliance with electrical safety requirements. It was also designed for a long fault-free life. However, the life expectancy of your product can be drastically reduced by improper treatment during unpacking and installation. Therefore, in the interest of your own safety and of the correct operation of your new Kontron product, you are requested to conform with the following guidelines.

High Voltage Safety Instructions



Warning!

All operations on this device must be carried out by sufficiently skilled personnel only.



Caution, Electric Shock!

Before installing a not hot-swappable Kontron product into a system always ensure that your mains power is switched off. This applies also to the installation of piggybacks.

Serious electrical shock hazards can exist during all installation, repair and maintenance operations with this product. Therefore, always unplug the power cable and any other cables which provide external voltages before performing work.

Special Handling and Unpacking Instructions



ESD Sensitive Device!

Electronic boards and their components are sensitive to static electricity. Therefore, care must be taken during all handling operations and inspections of this product, in order to ensure product integrity at all times.

Do not handle this product out of its protective enclosure while it is not used for operational purposes unless it is otherwise protected.

Whenever possible, unpack or pack this product only at EOS/ESD safe work stations. Where a safe work station is not guaranteed, it is important for the user to be electrically discharged before touching the product with his/her hands or tools. This is most easily done by touching a metal part of your system housing.

It is particularly important to observe standard anti-static precautions when changing piggybacks, ROM devices, jumper settings etc. If the product contains batteries for RTC or memory backup, ensure that the board is not placed on conductive surfaces, including anti-static plastics or sponges. They can cause short circuits and damage the batteries or conductive circuits on the board.



General Instructions on Usage

In order to maintain Kontron's product warranty, this product must not be altered or modified in any way. Changes or modifications to the device, which are not explicitly approved by Kontron and described in this manual or received from Kontron's Technical Support as a special handling instruction, will void your warranty.

This device should only be installed in or connected to systems that fulfill all necessary technical and specific environmental requirements. This applies also to the operational temperature range of the specific board version, which must not be exceeded. If batteries are present, their temperature restrictions must be taken into account.

In performing all necessary installation and application operations, please follow only the instructions supplied by the present manual.

Keep all the original packaging material for future storage or warranty shipments. If it is necessary to store or ship the board, please re-pack it as nearly as possible in the manner in which it was delivered.

Special care is necessary when handling or unpacking the product. Please consult the special handling and unpacking instruction on the previous page of this manual.



Two Year Warranty

Kontron grants the original purchaser of Kontron's products a **TWO YEAR LIMITED HARDWARE WARRANTY** as described in the following. However, no other warranties that may be granted or implied by anyone on behalf of Kontron are valid unless the consumer has the express written consent of Kontron.

Kontron warrants their own products, excluding software, to be free from manufacturing and material defects for a period of 24 consecutive months from the date of purchase. This warranty is not transferable nor extendible to cover any other users or long-term storage of the product. It does not cover products which have been modified, altered or repaired by any other party than Kontron or their authorized agents. Furthermore, any product which has been, or is suspected of being damaged as a result of negligence, improper use, incorrect handling, servicing or maintenance, or which has been damaged as a result of excessive current/voltage or temperature, or which has had its serial number(s), any other markings or parts thereof altered, defaced or removed will also be excluded from this warranty.

If the customer's eligibility for warranty has not been voided, in the event of any claim, he may return the product at the earliest possible convenience to the original place of purchase, together with a copy of the original document of purchase, a full description of the application the product is used on and a description of the defect. Pack the product in such a way as to ensure safe transportation (see our safety instructions).

Kontron provides for repair or replacement of any part, assembly or sub-assembly at their own discretion, or to refund the original cost of purchase, if appropriate. In the event of repair, refunding or replacement of any part, the ownership of the removed or replaced parts reverts to Kontron, and the remaining part of the original guarantee, or any new guarantee to cover the repaired or replaced items, will be transferred to cover the new or repaired items. Any extensions to the original guarantee are considered gestures of goodwill, and will be defined in the "Repair Report" issued by Kontron with the repaired or replaced item.

Kontron will not accept liability for any further claims resulting directly or indirectly from any warranty claim, other than the above specified repair, replacement or refunding. In particular, all claims for damage to any system or process in which the product was employed, or any loss incurred as a result of the product not functioning at any given time, are excluded. The extent of Kontron liability to the customer shall not exceed the original purchase price of the item for which the claim exists.

Kontron issues no warranty or representation, either explicit or implicit, with respect to its products' reliability, fitness, quality, marketability or ability to fulfil any particular application or purpose. As a result, the products are sold "as is," and the responsibility to ensure their suitability for any given task remains that of the purchaser. In no event will Kontron be liable for direct, indirect or consequential damages resulting from the use of our hardware or software products, or documentation, even if Kontron were advised of the possibility of such claims prior to the purchase of the product or during any period since the date of its purchase.

Please remember that no Kontron employee, dealer or agent is authorized to make any modification or addition to the above specified terms, either verbally or in any other form, written or electronically transmitted, without the company's consent.



This page has been intentionally left blank.





Chapter

1

Introduction



This page has been intentionally left blank.





1. Introduction

1.1 Board Overview

The CP6012 is a highly integrated 6U CompactPCI system controller board based on the Intel® Core™ Duo and the Intel® Core™2 Duo microprocessors combined with the high-performance Intel® E7520 and Intel® 6300ESB server-class chipsets.

The board is capable of supporting the Intel® Core™ Duo and the Intel® Core™2 Duo processor versions in 65 nm technology with 64 kB L1 and up to 4 MB L2 cache in a 479 µFCBGA package with frequencies ranging from 1.5 GHz up to 2.16 GHz providing up to 667 MHz front side bus speed.

The Intel® Core™ Duo and the Intel® Core™2 Duo are low-power dual-core processors supporting Intel's Virtualization Technology (VT). The Intel® Core™ Duo consists of two cores and up to 2 MB L2 cache shared by both cores. The Intel® Core™2 Duo consists of two cores, up to 4 MB L2 cache shared by both cores, Intel® Extended Memory 64 Technology (Intel® EM64T), and enhanced address range for up to 64 GB memory. The Intel® Core™ Duo and the Intel® Core™ 2 Duo processors deliver optimized power-efficient computing and outstanding dual-core performance with low power consumption.

The board includes two SODIMM sockets to provide up to 4 GB dual-channel, registered, second-generation Double Data Rate (DDR2) memory with Error Checking and Correcting (ECC) running at 400 MHz (PC3200). Two Intel® 82571EB Dual Gigabit Ethernet controllers, each utilizing a x4 lane PCI Express interconnection to the E7520 chipset, ensure maximum data throughput between processor and memory.

The CP6012 offers more features and expandability than other CompactPCI boards in its class. The board comes with four Gigabit Ethernet ports, up to four USB 2.0 ports, two Ultra ATA/100 interfaces with one of them connected to a CompactFlash type II socket, two onboard Serial ATA interfaces, one PMC interface with 64-bit/66 MHz on the PCI bus, one XMC interface utilizing a x8 lane PCI Express interconnection, rear I/O with several interfaces, and an ATI ES1000 2D Graphics accelerator with 64 MB of DDR2 memory for enhanced graphics performance with a VGA CRT-display interface. Several onboard connectors provide additional expansion capability.

The board supports a configurable 64-bit/66 MHz, hot swap CompactPCI interface. In the System Master slot the interface is enabled, and if installed in a peripheral slot, the CP6012 is isolated from the CompactPCI bus.

A further feature of the CP6012 is its support of the PICMG CompactPCI Packet Switching Backplane Specification 2.16. When installed in a backplane which supports packet switching, the CP6012 can communicate via two Gigabit Ethernet interfaces with other peripherals.

Designed for stability, the board fits into all applications situated in industrial environments, including I/O intensive applications where only one slot is available for the CPU, making it a perfect core technology for long-life applications. Components with high temperature tolerance have been selected from embedded technology programs, and therefore offer long-term availability.

The board is offered with Linux®, Microsoft® Windows® XP, Windows® XP Embedded and Microsoft® Windows® Server 2003, and VxWorks® operating systems. Please contact Kontron for further information concerning the operation of the CP6012 with other operating systems.



1.2 Board-Specific Information

The CP6012 is a CompactPCI single-board computer based on the Intel® Core™ Duo and the Intel® Core™2 Duo processors and specifically designed for use in highly integrated platforms with solid mechanical interfacing for a wide range of industrial environment applications.

Some of the CP6012's outstanding features are:

- Supports all Intel® Core™ Duo and Intel® Core™2 Duo microprocessors with up to 667 MHz FSB
- 479-pin µFCBGA package
- 64 kB L1 and up to 4 MB L2 cache on-die, running at CPU speed
- Intel® E7520 and Intel® 6300ESB chipset
- Up to 4GB registered DDR2 SDRAM registered memory with ECC
- 2D high performance VGA controller, 32-bit/33 MHz PCI
- Analog display support up to 1600 x 1200 pixels at 16-bit and 75 Hz
- 64-bit / 66 MHz CompactPCI interface in accordance with the CompactPCI Spec. Rev 3.0
- PMC interface with rear I/O support and bezel cutout on front panel and PCI functionality, 64-bit/66 MHz PCI, 3.3V only
- XMC interface utilizing a x8 lane PCI Express
- Four Gigabit Ethernet interfaces utilizing a x4 lane PCI Express per Gigabit Ethernet controller
 - Two Gigabit Ethernet interfaces on the front panel
 - Two Gigabit Ethernet interfaces on rear I/O (PICMG 2.16)
- Two EIDE Ultra ATA/100 interfaces
- Two Serial ATA interfaces
- Socket for Serial ATA 2.5" hard disk for boards equipped with a narrow heat sink
- Onboard CompactFlash type II socket (True IDE)
- Up to four USB ports
 - Two USB 2.0 ports on the front panel
 - Two USB 2.0 ports on rear I/O
- AMI BIOS
- Two 1 MB onboard FWH for redundant BIOS
- Floppy disk interface on rear I/O
- Watchdog Timer
- Real-time clock
- Two COM ports (RS-232):
 - One COM port either on the front panel or on the rear I/O
 - One COM port on the rear I/O
- I/O extension connector (LPC)
- 4HP, 6U CompactPCI
- Jumperless board configuration
- Passive heat sink solution for forced-airflow cooling
- Hot swap capability: as system controller or as peripheral device
- Supports PICMG Packet Switching Backplane Specification 2.16
- Several rear I/O configurations
- Rear I/O on J3 and J5; optionally on J4
- IPMI compliant Baseboard Management Controller



1.3 System Expansion Capabilities

1.3.1 PMC Modules

The CP6012 has one PCI, 64-bit/66 MHz, 3.3V, rear I/O capable, PMC mezzanine interface. This interface supports a wide range of available PMC modules with PCI interface including all of Kontron's PMC modules and provides an easy and flexible way to configure the CP6012 for various application requirements.

For information on the PMC interface, refer to chapter 2.3.13, "PMC Interface".

1.3.2 XMC Modules

The CP6012 has one XMC mezzanine interface for support of x1, x2, x4 and x8 PCI Express XMC modules providing an easy and flexible way to configure the CP6012 for various application requirements.

For information on the XMC interface, refer to chapter 2.3.14, "XMC Interface".

1.3.3 CTM80-3 Rear I/O Module

The CTM80-3 rear I/O module has been designed for use with the CP6012 6U CompactPCI board from Kontron. This module provides comprehensive rear I/O functionality and may also be configured for use in other applications.

For further information concerning the CTM80-3 module, please refer to Appendix A.

1.3.4 CP6012-MK2.5SATA Assembly Kit

The CP6012 comes with an optional CP6012-MK2.5SATA assembly kit comprised of one CP6012-EXT-SATA module and the necessary components needed for mounting the module on the board. the CP6012-EXT-SATA module is required for connecting an onboard 2.5" Serial ATA HDD or SSD to the CP6012.

For further information concerning the CP6012-EXT-SATA module, please refer to Appendix B.



1.4 System Relevant Information

The following system relevant information is general in nature but should still be considered when developing applications using the CP6012.

Table 1-1: System Relevant Information

SUBJECT	INFORMATION
System Slot/System Master Functionality	<p>The CP6012 is designed for use as a System Master board whereby it can support up to 7 peripheral boards with up to 64-bit/66 MHz.</p> <p>It may, however, be operated in a peripheral slot in which case it does not support the CompactPCI bus interface.</p>
Peripheral Slot Functionality	<p>When installed in a peripheral slot, the CP6012 is electrically isolated from the CompactPCI bus. It receives power from the backplane and supports rear I/O and, if the system supports it, packet switching (in this case up to two channels of Gigabit Ethernet).</p>
Hot Swap Compatibility	<p>When operated as a System Master, the CP6012 supports individual clocks for each slot and ENUM signal handling is in compliance with the PICMG 2.1 Hot Swap Specification.</p> <p>When operated in a peripheral slot the CP6012 supports basic hot swap.</p>
Operating Systems	<p>The CP6012 can be operated under the following operating systems:</p> <ul style="list-style-type: none"> • Microsoft® Windows® XP with Service Pack 1 or higher • Microsoft® Windows® XP Embedded • Microsoft® Windows® Server 2003 • Linux® • VxWorks® <p>Please contact Kontron for further information concerning the operation of the CP6012 with other operating systems.</p>



1.5 Board Diagrams

The following diagrams provide additional information concerning board functionality and component layout.

1.5.1 Functional Block Diagram

Figure 1-1: CP6012 Functional Block Diagram

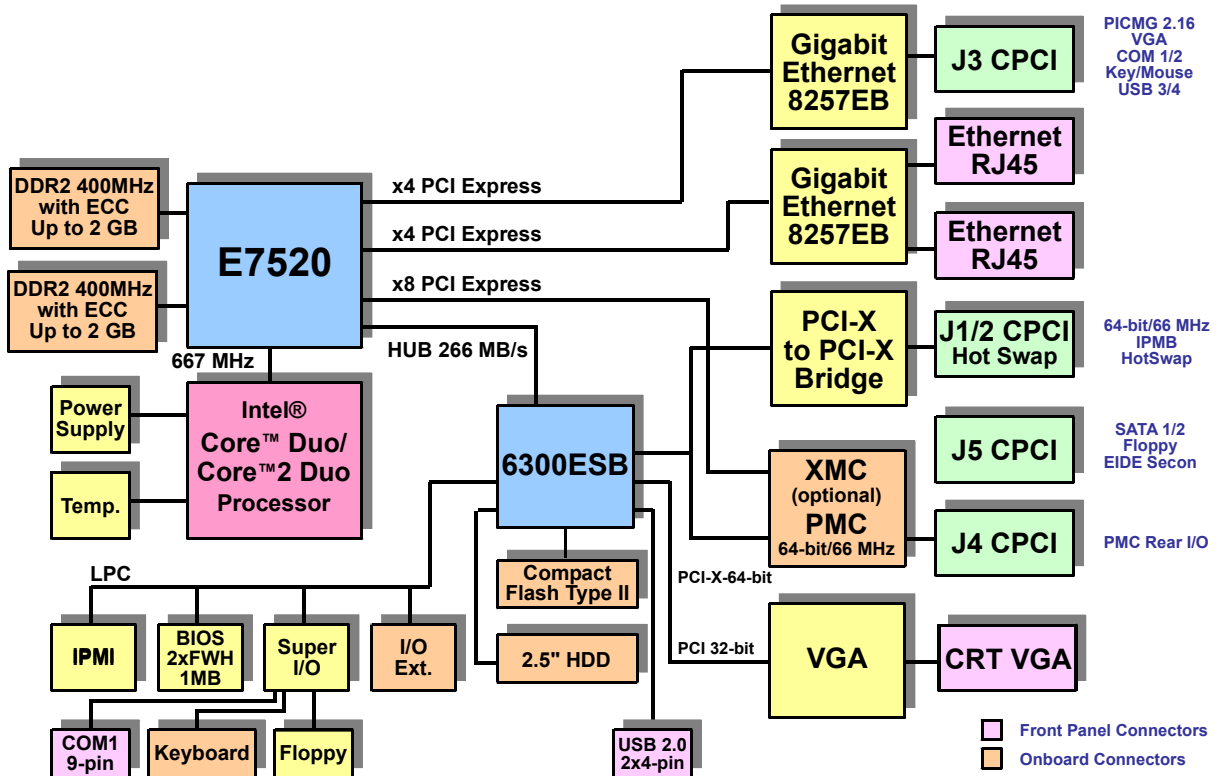



1.5.2 Front Panel

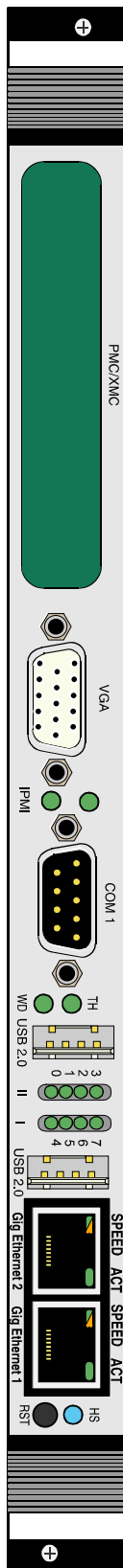

Figure 1-2: CP6012 Front Panel

Legend:

IPMI LEDs

IPMI (green): Indicate the software status of the IPMI controller

General Purpose LEDs

WD (green): Watchdog Status

TH (green): Overtemperature Status

HS (blue): Hot Swap Control

Front-I: General Purpose/POST code or board-specific

Front-II: General Purpose/POST code or board-specific

Integral Ethernet LEDs

ACT (green): Ethernet Link/Activity

SPEED (green/orange): Ethernet Speed

SPEED ON (orange): 1000 Mbit

SPEED ON (green): 100 Mbit

SPEED OFF: 10 Mbit



Note ...

If the TH LED and the WD LED are flashing during boot-up, a failure is indicated before the BIOS has started.

For further information, contact Kontron's Technical Support.

1.5.3 Board Layout

Figure 1-3: CP6012 Board Layout (Front View)

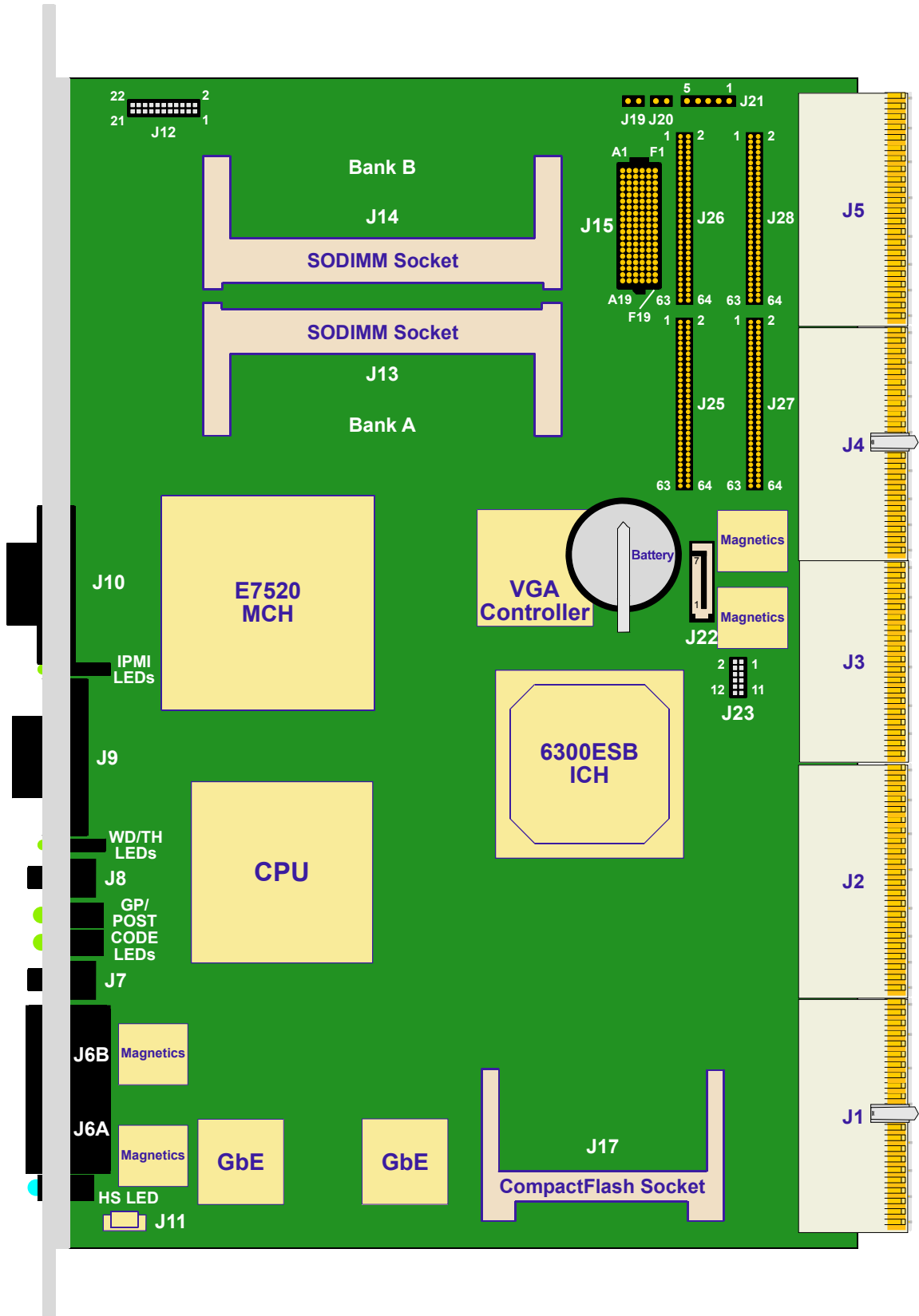
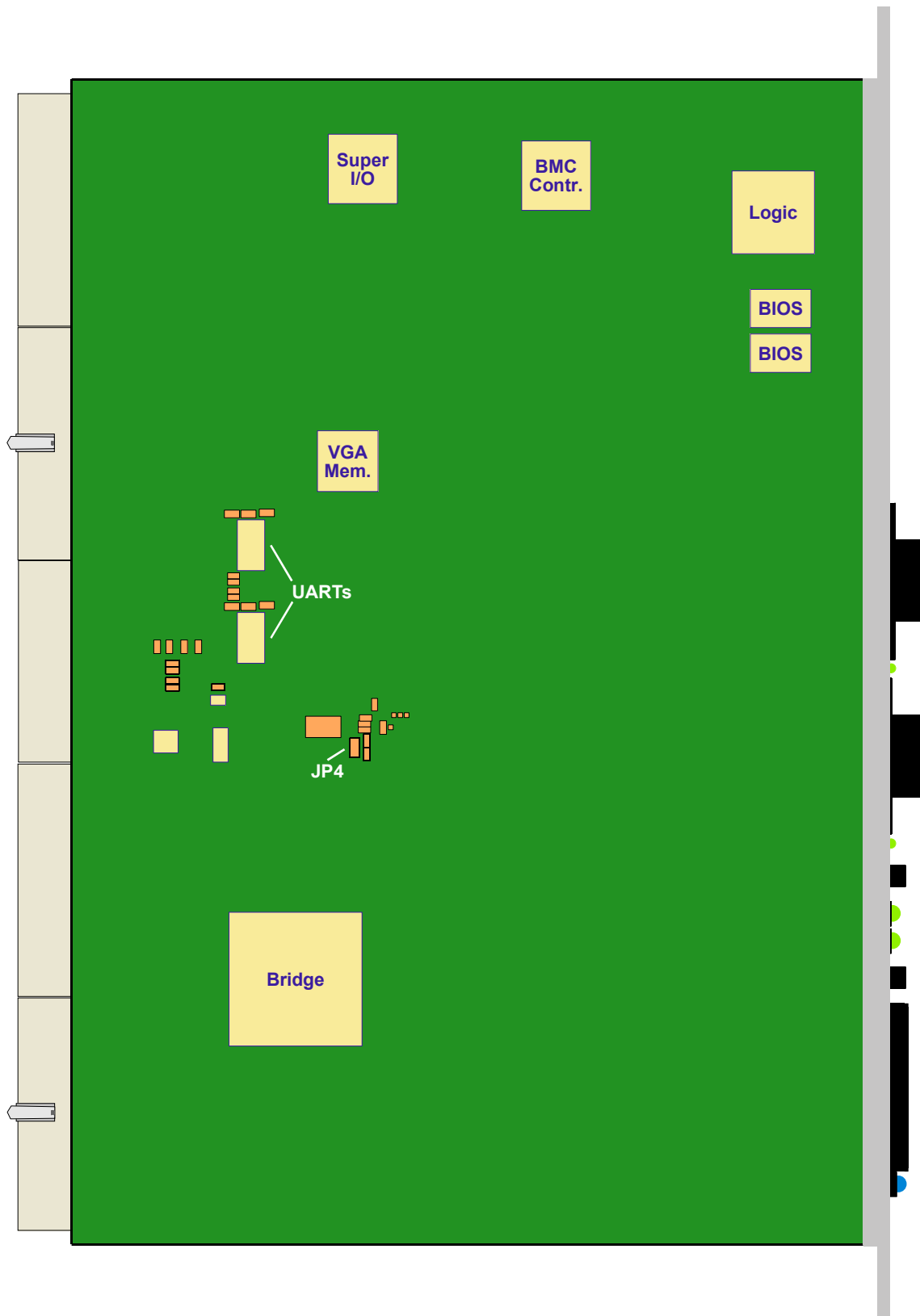



Figure 1-4: CP6012 Board Layout (Reverse View)





1.6 Technical Specification

Table 1-2: CP6012 Main Specifications

CP6012		SPECIFICATIONS
Processor and Memory	CPU	<p>The CP6012 supports the following microprocessors:</p> <ul style="list-style-type: none"> • Intel® Core™ Duo, T2500 (SV), 2.0 GHz, 667 MHz FSB, 2 MB L2 cache • Intel® Core™ Duo, L2400 (LV), 1.66 GHz, 667 MHz FSB, 2 MB L2 cache • Intel® Core™2 Duo, T7400 (SV), 2.16 GHz, 667 MHz FSB, 4 MB L2 cache • Intel® Core™2 Duo, L7400 (LV), 1.5 GHz, 667 MHz FSB, 4 MB L2 cache <p>All microprocessors are provided in a 479 µFCBGA packaging.</p>
	Memory	<p>Main Memory:</p> <ul style="list-style-type: none"> • Up to 4 GB dual-channel, registered DDR2 memory with Error Checking and Correcting (ECC) running at 400 MHz (PC3200) <p>Cache structure:</p> <ul style="list-style-type: none"> • 64 kB L1 on-die full speed processor cache <ul style="list-style-type: none"> • 32 kB for instruction cache • 32 kB for data cache • Up to 4 MB L2 on-die full speed processor cache <p>FLASH Memory:</p> <ul style="list-style-type: none"> • Two 1 MB FLASH for redundant BIOS <p>Memory Extension:</p> <ul style="list-style-type: none"> • CompactFlash socket type II (true IDE mode) <p>Serial EEPROM:</p> <ul style="list-style-type: none"> • 24LC64 (64 kbit)

Table 1-2: CP6012 Main Specifications (Continued)

CP6012		SPECIFICATIONS
Chipset	Intel® E7520	<p>Intel® E7520 Memory Controller Hub:</p> <ul style="list-style-type: none"> • Support for a single Intel® Core™ Duo or Intel® Core™2 Duo microprocessor • 64-bit AGTL/AGTL+ based System Bus interface up to 667 MHz • System Memory interface with optimized support for dual-channel, registered DDR2 SDRAM memory at 400 MHz with ECC • Two x4 PCI Express ports for Gigabit Ethernet interface • One x8 PCI Express port for XMC interface • RASUM (Reliability, Availability, Serviceability, Usability, and Manageability) features: <ul style="list-style-type: none"> • Memory error detection and reporting of 1- and 2-bit errors including correction of 1-bit failures • Integrated Memory Scrub Engine, which logs any uncorrectable memory errors • Support for automatic read retry on uncorrectable errors
	Intel® 6300ESB	<p>Intel® 6300ESB I/O Controller Hub:</p> <ul style="list-style-type: none"> • Dual channel SATA 150 interface • Integrated IDE controller Ultra ATA/100/66/33 • USB host interface with up to four USB 1.1 or USB 2.0 ports • Firmware Hub interface support • Low pin count interface • PCI Rev. 2.2 compliant with support for 64-bit/66 MHz PCI operations • PCI Rev. 2.2 compliant with support for 32-bit/33 MHz PCI operations • Power management logic support • Enhanced DMA controller, interrupt controller, and timer functions • System Management Bus (SMBus) compatible with most I²C™ devices • Hub interface for the E7520 MCH • RTC controller

Table 1-2: CP6012 Main Specifications (Continued)

CP6012		SPECIFICATIONS
Interfaces	CompactPCI	<p>Compliant with CompactPCI Specification PICMG® 2.0 R 3.0</p> <ul style="list-style-type: none"> • System Master operation • 64-bit/66 MHz master interface • 3.3V or 5V compliant <p>When the CP6012 is operated in a peripheral slot, the CompactPCI bus is electrically isolated (passive mode).</p>
	Rear I/O	<p>The following interfaces are routed to the rear I/O connector J3, J4 and J5:</p> <ul style="list-style-type: none"> • COM1 and COM2 (RS-232 signaling); no buffer on the rear I/O module is necessary • 2 x USB 2.0 • CRT VGA • PS/2 (Mouse/Keyboard) • 2 x Gigabit Ethernet (compliant with PICMG 2.16, R 1.0) • Secondary EIDE (ATA 100) • 2 x SATA 150 • PMC rear I/O • Floppy disk interface
	Hot Swap Compatible	<p>The CP6012 supports System Master hot swap functionality and application dependent hot swap functionality when used in a peripheral slot.</p> <p>When used as a System Master the CP6012 supports individual clocks for each slot and ENUM signal handling is in compliance with the PICMG 2.1 Hot Swap Specification.</p>
	VGA	<p>ATI ES1000 2D Graphics accelerator for enhanced graphics performance.</p> <ul style="list-style-type: none"> • Supports resolutions of up to 1600 x 1200 by 16-bit color resolution at a 75 Hz refresh rate or up to 1280 x 1024 by 32-bit color resolution at an 75 Hz refresh rate. • The graphics controller provides 64 MB video memory. • One CRT controller capable of supporting two identical simultaneous display paths.
	Gigabit Ethernet	<p>Up to four 10 Base-T/100 Base-TX/1000 Base-T Gigabit Ethernet interfaces based on two Intel® 82571EB Ethernet PCI Express bus controllers.</p> <ul style="list-style-type: none"> • Two channels on rear I/O • Two RJ45 connectors on the front panel • Automatic mode recognition (Auto-Negotiation) • Automatic cabling configuration recognition (Auto-MDI/X) <p>Cabling requirement: Category 5, UTP, four-pair cabling</p>
	USB	<p>Four USB ports supporting UHCI and EHCI:</p> <ul style="list-style-type: none"> • Two USB 2.0 connectors on the front panel • Two USB 2.0 on the rear I/O interface

Table 1-2: CP6012 Main Specifications (Continued)

CP6012		SPECIFICATIONS
Interfaces	Serial	Two 16C550-compatible UARTs on the rear I/O interface (RS-232 signaling), one thereof can be routed to the front panel
	PMC	CMC/PMC P1386/Draft 2.4a compliant mezzanine interface <ul style="list-style-type: none"> • Jn1, Jn2, Jn3 and Jn4 PCI mezzanine connectors for standard PMC modules • 64-bit/66 MHz PCI interface • Only 3.3V PCI signalling voltage • Rear I/O supported through the CompactPCI connector J4 • Supported voltages: 3.3 V, 5 V, +12 V, and -12 V
	XMC	XMC interface <ul style="list-style-type: none"> • Onboard XMC connector J15 • Up to x8 lanes PCI Express • Rear I/O supported through the PMC connector Jn4 (J27) to the CompactPCI connector J4
	Keyboard and Mouse	Keyboard and mouse are supported <ul style="list-style-type: none"> • USB Support on 4HP • PS/2 (keyboard and mouse) with rear I/O module (e.g. CTM80-3) • Onboard keyboard pinrow connector for debug purposes requiring an adapter in order to be connected to a regular keyboard
	Mass Storage	EIDE Ultra ATA/100/66/33: <ul style="list-style-type: none"> • Two onboard Ultra ATA/100 interfaces, one on CompactFlash and one on Rear I/O • Up to three devices (one CompactFlash and up to two hard disks or CD-ROMs) Onboard 2.5" hard disk: <ul style="list-style-type: none"> • Onboard 2.5" hard disk is supported on J23, a 12-pin Serial ATA interface (only for boards equipped with a narrow heat sink) • For this Serial ATA interface, the CP6012-EXT-SATA module is used CompactFlash: <ul style="list-style-type: none"> • CompactFlash type II socket (true IDE mode and DMA support) • Supports type I and II CompactFlash cards and Microdrive™ SATA: Integrated Serial ATA Host Controllers <ul style="list-style-type: none"> • Provide independent DMA operation on 2 channels: <ul style="list-style-type: none"> • One SATA channel switchable to rear I/O via BIOS (for standard HDDs) • One SATA channel routed either to the SATA connector J22 or to rear I/O (for 2.5" HDDs) • Data transfer rates up to 150 MB/s Floppy Disk (only with rear I/O module): <ul style="list-style-type: none"> • Supports 5.25" or 3.5" floppy drives • 1.44 or 2.88 MB, 3.5" floppy disks
	I/O Extension Interface	I/O extension interface: <ul style="list-style-type: none"> • LPC devices



Table 1-2: CP6012 Main Specifications (Continued)

CP6012		SPECIFICATIONS
Sockets	Front Panel Connectors	<ul style="list-style-type: none"> VGA: 15-pin, D-Sub connector USB: two 4-pin connectors Ethernet: two RJ-45 connectors COM: 9-pin, D-Sub connector PMC/XMC front panel
	Onboard Connectors	<ul style="list-style-type: none"> CompactFlash socket for type I, II and Microdrive™ devices (primary EIDE interface) I/O extension connector PMC connectors J25 - J28 (Jn1 - Jn4) XMC connector, J15 Two SATA connectors <ul style="list-style-type: none"> one 7-pin, standard SATA connector one 12-pin, SATA extension connector CompactPCI Connector J1 and J2 (J3 - J5 optional) Two 200-pin SODIMM sockets
HW Monitoring	LEDs	<p>System status:</p> <ul style="list-style-type: none"> TH (green): Overtemperature Status WD (green): Watchdog Status IPMI: Control information <p>Gigabit Ethernet status:</p> <ul style="list-style-type: none"> ACT (green): network activity SPEED (green/orange): network speed <p>General Purpose LEDs:</p> <ul style="list-style-type: none"> I (green): General Purpose/POST code or board-specific II (green): General Purpose/POST code or board-specific
	Watchdog	Software configurable Watchdog generates IRQ, NMI, or hardware reset.
	Thermal Management	<p>CPU overtemperature protection is provided by:</p> <ul style="list-style-type: none"> Internal processor temperature control unit CPU shut down via hardware monitor
	System Monitor	<p>In SCH3112 integrated hardware monitor for supervision of:</p> <ul style="list-style-type: none"> Several system power voltages Two fan speed inputs Board temperature
	IPMI	<p>Baseboard Management Controller (BMC) that supports two keyboard controller-style interfaces (KCS) compliant with:</p> <ul style="list-style-type: none"> IPMI specification 1.5, revision 1.5 PICMG 2.9 specification <p>IPMI supports two IPMB busses via the J1 and J2 connectors.</p>

Table 1-2: CP6012 Main Specifications (Continued)

CP6012		SPECIFICATIONS
Software	Software BIOS	AMI BIOS with 1 MB Flash memory with the following features: <ul style="list-style-type: none"> • QuickBoot • QuietBoot • BootBlock • LAN boot capability for diskless systems (standard PXE) • Boot from USB floppy disk drive • BIOS boot support for USB keyboards • Plug and Play capability • BIOS parameters are saved in the EEPROM • Board serial number is saved within the EEPROM • PC Health Monitoring
	Operating Systems	Operating systems supported: <ul style="list-style-type: none"> • Microsoft® Windows® XP • Microsoft® Windows® XP Embedded • Microsoft® Windows® Server 2003 • Linux • VxWorks
General	Mechanical	6U, 4HP, CompactPCI compliant form factor
	Power Consumption	See Chapter 5 for details
	Temperature Ranges	Operational: 0°C to +60°C Standard Storage: -55°C to +85°C Without hard disk and without battery -40°C to +65°C With hard disk and without battery  <p>Note ... When a battery is installed, refer to the operational specifications of the battery as this determines the storage temperature of the CP6012 (See "Battery" below).</p>
	Battery	3.0V lithium battery for RTC with battery socket. Recommended types: <ul style="list-style-type: none"> • VARTA CR2025 • PANASONIC BR2020 Temperature ranges: Operational: -20°C to +70°C typical (refer to the battery manufacturer's specifications for exact range) Storage: -55°C to +70°C typical (no discharge)
	Heat Sink	The following heat sink types are used on the CP6012: <ul style="list-style-type: none"> • Narrow heat sink • Wide heat sink (obsolete)
	Climatic Humidity	93% RH at 40 °C, non-condensing (acc. to IEC 60068-2-78)
	Dimensions	233.35 mm x 160 mm
	Board Weight	560 g (boards with low voltage processor and without mezzanine cards) 680 g (boards with standard voltage processor and without mezzanine cards) 690 g (boards with standard voltage processor and wide heat sink and without mezzanine cards)



1.7 Kontron Software Support

Kontron is one of the few CompactPCI and VME manufacturers providing inhouse support for most of the industry-proven real-time operating systems that are currently available. Due to its close relationship with the software manufacturers, *Kontron* is able to produce and support BSPs and drivers for the latest operating system revisions thereby taking advantage of the changes in technology.

Finally, customers possessing a maintenance agreement with *Kontron* can be guaranteed hotline software support and are supplied with regular software updates. A dedicated web site is also provided for online updates and release downloads.

1.8 Standards

This product complies with the requirements of the following standards:

Table 1-3: Standards

TYPE	ASPECT	STANDARD
CE	Emission	EN55022 EN61000-6-3
	Immission	EN55024 EN61000-6-2
	Electrical Safety	EN60950-1
Mechanical	Mechanical Dimensions	IEEE 1101.10
Environmental	Climatic Humidity	IEC60068-2-78
	WEEE	Directive 2002/96/EC Waste electrical and electronic equipment
	RoHS	Directive 2002/95/EC Restriction of the use of certain hazardous substances in electrical and electronic equipment

In addition, boards ordered with the ruggedized service comply with the following standards as well.

Table 1-4: Additional Standards for Boards Ordered with Ruggedized Service

TYPE	ASPECT	STANDARD	REMARKS
Environmental	Vibration (Sinusoidal)	IEC60068-2-6	Ruggedized version test parameters: <ul style="list-style-type: none"> • 10-300 (Hz) frequency range • 2 (g) acceleration • 1 (oct/min) sweep rate • 10 cycles/axis • 3 axis
	Random Vibration (Broadband)	IEC60068-2-64	Ruggedized version test parameters: <ul style="list-style-type: none"> • 20-500Hz, 0.05 (g²/Hz) PSD • 500-2000Hz, 0.005 (g²/Hz) PSD • 3.5 (g RMS) acceleration • 30 (min) test time/axis • 3 axis
	Permanent Shock	IEC60068-2-29	Ruggedized version test parameters: <ul style="list-style-type: none"> • 15 (g) acceleration • 11 (ms) pulse duration • 500 bumps per direction • 6 directions • 1 (s) recovery time
	Single Shock	IEC60068-2-27	Ruggedized version test parameters: <ul style="list-style-type: none"> • 30 (g) acceleration • 9 (ms) pulse duration • 3 shocks per direction • 6 directions • 5 (s) recovery time

1.9 Related Publications

The following publications contain information relating to this product.

Table 1-5: Related Publications

PRODUCT	PUBLICATION
CompactPCI Systems and Boards	CompactPCI Specification 2.0, Rev. 3.0 CompactPCI Packet Switching Backplane Specification PICMG 2.16 Rev. 2.0 CompactPCI System Management Specification PICMG 2.9 Rev. 1.0 CompactPCI Hot Swap Specification PICMG 2.1 Rev. 2.0
	Kontron CompactPCI Backplane Manual, ID 24229
CompactFlash Cards	CF+ and CompactFlash Specification Revision 2.1
PMC Modules	IEEE 1386-2001, IEEE Standard for a Common Mezzanine Card (CMC) Family IEEE 1386.1-2001, IEEE Standard Physical and Environmental Layers for PCI Mezzanine Cards (PMC)



Chapter **2**

Functional Description



This page has been intentionally left blank.





2. Functional Description

2.1 CPU, Memory and Chipset

2.1.1 CPU

The CP6012 supports the latest Intel® Core™ Duo and Intel® Core™2 Duo processor family up to speeds of 2.16 GHz with up to 667 MHz FSB, such as:

- Intel® Core™ Duo, L2400 (LV), 1.66 GHz, 667 MHz FSB, 2 MB L2 cache
- Intel® Core™ Duo, T2500 (SV), 2.0 GHz, 667 MHz FSB, 2 MB L2 cache
- Intel® Core™2 Duo, L7400 (LV), 1.5 GHz, 667 MHz FSB, 4 MB L2 cache
- Intel® Core™2 Duo, T7400 (SV), 2.16 GHz, 667 MHz FSB, 4 MB L2 cache

The Intel® Core™ Duo consists of two cores and up to 2 MB L2 cache shared by both cores. The Intel® Core™2 Duo consists of two cores, up to 4 MB L2 cache shared by both cores, Intel® Extended Memory 64 Technology (Intel® EM64T), and enhanced address range for up to 64 GB memory. The Intel® Core™ Duo and the Intel® Core™2 Duo processors deliver optimized power-efficient computing and outstanding dual-core performance with low power consumption.

The Intel® Core™ Duo and the Intel® Core™2 Duo support the latest Intel's Virtualization Technology (VT), which allows a platform to run multiple operating systems and applications in independent partitions, such as performing system upgrades and maintenance without interrupting the system or the application, keeping software loads and virus attacks separate, combining multiple servers in one system, etc. With processor and I/O enhancements to Intel's various platforms, Intel Virtualization Technology improves the performance and robustness of today's software-only virtual machine solutions.

Furthermore, the Intel® Core™ Duo and the Intel® Core™2 Duo processors also support the Intel® SpeedStep® technology which enables real-time dynamic switching of the voltage and frequency between several modes. This is achieved by switching the bus ratios, core operating voltage, and core processor speeds without resetting the system. The frequency for the processor may also be selected in the BIOS or via the operating system.

The following list sets out some of the key features of the Intel® Core™ Duo and the Intel® Core™2 Duo processors:

- Two mobile execution cores in one single processor
- Support of Intel's Virtualization Technology (Vanderpool)
- Support of Intel Architecture with Dynamic Execution
- Outstanding dual-core performance with low power consumption
- On-die, primary 32 kB instruction cache and 32 kB write-back data cache
- On-die, L1 and L2 cache with Advanced Transfer Cache Architecture
- Advanced Branch Prediction and Data Prefetch Logic
- Streaming SIMD Extensions 3 (SSE3)
- Up to 667 MHz, Source-Synchronous Front Side Bus (FSB)
- Advanced Power Management features including Enhanced Intel® SpeedStep® technology
- Intel® Extended Memory 64 Technology for 64-bit computing (only with Intel® Core™2 Duo)
- Enhanced address range for up to 64 GB memory (only with Intel® Core™2 Duo)

The following tables indicate the Intel® Core™ Duo and the Intel® Core™2 Duo processors supported on the CP6012, their maximum power dissipation and their frequency in the various SpeedStep® modes.

Table 2-1: Processors Supported on the CP6012

SPEED	Core™ Duo 1.66 GHz (LV) 2 MB L2 Cache	Core™ Duo 2.0 GHz (SV) 2 MB L2 Cache	Core™2 Duo 1.5 GHz (LV) 4 MB L2 Cache	Core™2 Duo 2.16 GHz (SV) 4 MB L2 Cache
PACKAGE	µFCBGA	µFCBGA	µFCBGA	µFCBGA
L2 CACHE	2 MB	2 MB	4 MB	4 MB
FSB	667 MHz	667 MHz	667 MHz	667 MHz

Table 2-2: Maximum Power Dissipation of Processors (CPU only)

FREQUENCY MODE	Core™ Duo 1.66 GHz (LV) 2 MB L2 Cache	Core™ Duo 2.0 GHz (SV) 2 MB L2 Cache	Core™2 Duo 1.5 GHz (LV) 4 MB L2 Cache	Core™2 Duo 2.16 GHz (SV) 4 MB L2 Cache
Maximum Power HFM ¹⁾	15 W	31 W	17 W	34 W
Maximum Power LFM ²⁾	13.1 W	13.1 W	15.1 W	20 W

1) HFM High Frequency Mode (maximum frequency of the CPU)

2) LFM Low Frequency Mode (frequency is 1.0 GHz)

Table 2-3: CPU Frequency in the Various SpeedStep® Modes

FREQUENCY	Core™ Duo 1.66 GHz (LV) 2 MB L2 Cache	Core™ Duo 2.0 GHz (SV) 2 MB L2 Cache	Core™2 Duo 1.5 GHz (LV) 4 MB L2 Cache	Core™2 Duo 2.16 GHz (SV) 4 MB L2 Cache
2.16 GHz	--	--	--	x
2.0 GHz	--	x	--	--
1.66 GHz	x	x	--	x
1.5 GHz	--	--	x	--
1.33 GHz	x	x	--	x
1.0 GHz	x	x	x	x



2.1.2 Memory

The CP6012 supports a dual-channel (72-bit), registered Double Data Rate (DDR2) memory with Error Checking and Correcting (ECC) running at 400 MHz (PC3200). It provides two 200-pin SODIMM sockets for the DDR2 SODIMM modules that support up to 4 GB system memory. The available memory module configuration can be either 512 KB, 1 GB, 2 GB, or 4 GB.

There are several Reliability, Availability, Serviceability, Usability, and Manageability (RASUM) features available for the memory interface:

- Memory error detection and reporting of 1 and 2 bit errors and correction of 1 bit failures
- Integrated Memory Scrub Engine, the scrub engine logs any uncorrectable memory error
- Support for automatic read retry on uncorrectable errors

Only qualified DDR2 SODIMM modules from Kontron are authorized by Kontron for use with the CP6012.

Table 2-4: Memory Options Utilizing SODIMM Sockets

BANK A	BANK B	TOTAL
512 MB	--	512 MB
512 MB	512 MB	1 GB
1 GB	1 GB	2 GB
2 GB	2 GB	4 GB



Warning!

Even though the registered DDR2 SODIMM modules from Kontron have the same keying as conventional DDR SODIMM modules, their pinout is different.

For this reason, only registered DDR2 SODIMM modules from Kontron are permitted to be used on the CP6012. Use of any other type of DDR2 SODIMM modules on the CP6012 will void your warranty and result in damage to the board or the system.



2.1.3 Intel® E7520 Chipset Overview

The Intel® E7520 chipset consists of the following devices:

- Intel® E7520 Memory Controller Hub (MCH)
- Intel® 6300ESB I/O Controller Hub (ICH)

The MCH provides the processor interface for the Intel® Core™ Duo and the Intel® Core™2 Duo microprocessors, the memory bus, the PCI Express bus, and the hub link interface to ICH. The ICH is a centralized controller for the boards' I/O peripherals such as the USB 2.0 and the IDE port.

2.1.3.1 Memory Controller Hub E7520

The E7520 Memory Controller Hub (MCH) is a highly integrated hub that provides the CPU interface, a dual-channel DDR2 SDRAM system memory interface (optimized for DDR400/PC3200), two x4 and one x8 PCI Express interfaces, and a high-speed hub link interface to the 6300ESB I/O Controller Hub.

2.1.3.2 I/O Controller Hub 6300ESB

The 6300ESB is a highly integrated multifunctional I/O Controller Hub that provides the interface to two PCI Buses, and integrates many of the functions needed in today's PC platforms, such as Ultra DMA 100/66/33 controller, SATA 150, USB host controller supporting USB 2.0, LPC interface and FWH Flash BIOS interface controller. The 6300ESB communicates with the host controller over a dedicated hub interface.

The I/O Controller Hub feature set comprises:

- Dual channel SATA 150 interface
- Integrated IDE controller Ultra ATA/100/66/33
- USB host interface with up to four USB 1.1 or USB 2.0 ports
- Firmware Hub interface support
- Low pin count interface
- PCI Rev. 2.2 compliant with support for 32-bit/33 MHz PCI operations
- PCI Rev. 2.2 compliant with support for 64-bit/66 MHz PCI operations
- Power management logic support
- Enhanced DMA controller, interrupt controller, and timer functions
- System Management Bus (SMBus) compatible with most I²C™ devices
- Hub interface for the E7520 MCH
- RTC controller



2.2 Peripherals

The following standard peripherals are available on the CP6012 board:

2.2.1 Timer

The CP6012 is equipped with the following timers:

- Real-time clock

The 6300ESB contains a MC146818A compatible real-time clock. The real-time clock performs timekeeping functions and includes 256 bytes of general purpose battery-backed CMOS RAM. Features include an alarm function, programmable periodic interrupt and a 100-year calendar. All battery-backed CMOS RAM data remains stored in an additional EEPROM. This prevents data loss.

- In addition to the three 8254-style counters, the 6300ESB includes three individual multimedia event timers that may be used by the operating system. They are implemented as a single counter each with its own comparator and value register.
- Hardware delay timer for short reliable delay times

2.2.2 Watchdog Timer

A Watchdog Timer is provided, which forces either an IRQ5, NMI, or Reset condition (configurable in the Watchdog Register). The Watchdog Timer can be programmed in 12 steps ranging from 125 msec up to 256 seconds. Once the Watchdog Timer is enabled, it cannot be disabled except via a system reset.

2.2.3 Battery

The CP6012 is provided with a 3.0 V “coin cell” lithium battery for the RTC.

The lithium battery must be replaced with an identical battery or a battery type recommended by the manufacturer. Suitable batteries include the VARTA CR2025 and PANASONIC BR2020.

The typical life expectancy of a 170 mAh battery (VARTA CR2025) is 5 - 6 years with an average on-time of 8 hours per working day at an operating temperature of 30°C. However, this typical value varies considerably because the life expectancy is dependent on the operating temperature and the standby time (shutdown time) of the system in which it operates.

To ensure that the lifetime of the battery has not been exceeded, it is recommended to exchange the battery after 4 - 5 years.



Note ...

The user must be aware that the battery's operational temperature range is less than that of the CP6012's storage temperature range.

For exact range information, refer to the battery manufacturer's specifications.



2.2.4 Reset

The CP6012 is automatically reset by a precision voltage monitoring circuit that detects a drop in voltage below the acceptable operating limit of 4.25 V for the 5 V line and below 2.8 V for the 3.3 V line, or in the event of a power failure of a DC/DC converter. Other reset sources include the Watchdog Timer and the RST (Reset) switch on the front panel. The CP6012 responds to any of these sources by initializing local peripherals.

A reset will be generated under the following conditions:

- +5 V supply falls below 4.25 V (typ.)
- +3.3 V supply falls below 2.8 V (typ.)
- Power failure of at least one onboard DC/DC converter
- Front panel switch RST (RESET) pressed
- Watchdog timeout
- CompactPCI backplane PRST input

2.2.5 SMBus Devices

The CP6012 provides a System Management Bus (SMBus) for access to several system monitoring and configuration functions. The SMBus consists of a two-wire I²C bus interface. The following table lists the SMBus devices and their addresses.

Table 2-5: SMBus Device Addresses

DEVICE	SMB ADDRESS
EEPROM 24LC64	1010101xb
Clock (core)	1101001xb
Clock (PCI Express)	1101110xb
SPD (channel A)	1010011xb
SPD (channel B)	1010010xb

2.2.6 Thermal Management/System Monitoring

The SCH3112 can be used to monitor several critical hardware parameters of the system, including power supply voltages, fan speeds and temperatures, all of which are very important for the proper operation and stability of a high-end computer system. The SCH3112 provides an LPC interface.

The voltages +12 V, +5 V, +3.3 V, +1.8 V, and Vcore are supervised. Two fan tachometer outputs can be measured using the SCH3112's FAN inputs.

The temperature sensors on the SCH3112 monitor the temperature around the DDR2 memory module and the internal temperature of the SCH3112.



2.2.7 Serial EEPROM

This EEPROM is connected to the I²C bus provided by the 6300ESB.

Table 2-6: EEPROM Address Map

ADDRESS	FUNCTION
0x000 - 0x0FF	CMOS backup
0x100 - 0x1FF	Production data
0x200 - 0x3FF	OS Boot parameter
0x400 - 0x1FFF	User

2.2.8 FLASH Memory

There are two flash devices available as described below, one for the BIOS and one for the CompactFlash socket.

2.2.8.1 BIOS FLASH (Firmware Hub)

The CP6012 provides two redundant non-volatile Firmware Hub Flash chips (2 x 1MB). The fail-over mechanism for the BIOS recovery can be controlled via the BMC controller or the jumper J19. If one Firmware Hub Flash is corrupted, the BMC can enable the second Firmware Hub Flash and boot the system again.

For detailed BIOS information, refer to the CP6012 BIOS Guide.

2.2.8.2 CompactFlash

CompactFlash is a very small removable mass storage device. It provides true IDE functionality compatible with the 16-bit ATA/ATAPI-4 interface.

For further information on the CompactFlash, refer to section 2.3.7.1, CompactFlash Socket.



2.3 Board Interfaces

2.3.1 Front Panel LEDs

The CP6012 is equipped with two IPMI LEDs, one Watchdog LED, one Overtemperature LED, eight General Purpose/POST code or board-specific LEDs (four LEDs for Front-I and four LEDs for Front-II), and one Hot Swap LED. Their functionality is described in the following chapters.

2.3.1.1 IPMI LEDs

The IPMI LEDs show the software status of the IPMI controller. The following table indicates the function of the IPMI LEDs.

Table 2-7: IPMI LEDs Function

	LEFT LED		RIGHT LED	
Normal status	OFF		SLOW BLINKING	
Blinking speed	Slow (100 msec ON; 1.4 sec OFF)	Fast 8 x (150 msec ON; 50 msec OFF)	Slow (250 msec ON; 3 sec OFF)	Fast 8 x (150 msec ON; 50 msec OFF)
Signification	Management Controller request attention to SMS/SMM (this may occur when there is a message waiting for the SMS)	Send/Receive data through the IPMB bus	The Management Controller is running normally; it's a heart beat	Send/Receive data through the KCS interface

2.3.1.2 Watchdog and Overtemperature LEDs

The CP6012 provides one LED for Watchdog (WD LED) and one for Overtemperature (TH LED) status. If the TH LED and the WD LED are flashing during boot-up, a failure is indicated before the BIOS has started. In this case, check the power supply. If the power supply appears to be functional and the LEDs are still flashing, contact Kontron's Technical Support.



Note ...

If only the Overtemperature LED flashes on and off at regular intervals, it indicates that the processor junction temperature has reached a level beyond which permanent silicon damage may occur. Upon assertion of Thermtrip, the processor will shut off its internal clocks (thus halting program execution) in an attempt to reduce the processor junction temperature.

Once activated, Thermtrip remains latched until a cold restart of the CP6012 is undertaken (all power off and then on again).

Table 2-8: Watchdog and Overtemperature LEDs Function

LED	FUNCTION DURING BOOT-UP	DEFAULT FUNCTION AFTER BOOT-UP
WD (green)	A failure is indicated before the BIOS has started	Watchdog Status
TH (green)	A failure is indicated before the BIOS has started	Overtemperature Status The TH LED states are: <ul style="list-style-type: none"> • Flicker: If the CPU reaches approximately 100°C • On: In case of overtemperature of the CPU, i.e. the CPU has reached a temperature above 100°C • Long blink: If the CPU has been shut off, i.e. the CPU has reached a temperature above 125°C

2.3.1.3 Front-I and Front-II General Purpose LEDs

There are two sets of General Purpose LEDs available on the front panel of the CP6012 which are designed to indicate the boot-up POST code and are available to the application as General Purpose LEDs or board-specific signals.

The POST code is indicated during the boot-up phase. After boot-up, the Front-I and Front-II LEDs indicate Port 80, General Purpose or board-specific signals, depending on the BIOS settings. The default setting after boot-up is General Purpose.

Together Front-I and Front-II indicate a two-place hexadecimal number. Front-II is the lower nibble, Front-I is the higher nibble. A '1' is indicated by a lit LED. The LSB is 0, the MSB is 7. The default setting is General Purpose and all LEDs are not lit.

Table 2-9: Front-I and Front-II LEDs Function

FRONT-I & FRONT-II LEDs	GENERAL PURPOSE	PORT 80	BOARD-SPECIFIC
0	User-defined	LSB (8-bit data register, POST code, Linux boot code)	HDD activity on primary channel
1	User-defined		HDD activity on secondary channel
2	User-defined		HDD activity on SATA channel
3	User-defined		Reserved
4	User-defined		Reserved
5	User-defined		Reserved
6	User-defined		Reserved
7	User-defined	MSB	Reserved

2.3.1.4 Hot Swap LED

On the CP6012, a blue HS LED can be switched on or off by software. It may be used, for example, to indicate that the shutdown process is finished and the board is ready for extraction. It may also be used for general purposes.



2.3.2 USB Interfaces

The CP6012 supports four USB 2.0 ports (two on the front I/O and two on the rear I/O). On the two rear I/O ports it is strongly recommended to use a cable less than 3 meters in length for USB 2.0 devices. All four ports are high-speed, full-speed, and low-speed capable. High-speed USB 2.0 allows data transfers of up to 480 Mb/s - 40 times faster than a full-speed USB (USB 1.1).

One USB peripheral may be connected to each port. To connect more than four USB devices an external hub is required.

The CP6012 has two USB interfaces implemented on two 4-pin connectors on the front panel. The following figure and table provide pinout information for the USB port connectors J7 and J8.

Figure 2-1: USB Connectors J7 and J8 **Table 2-10: USB Connectors J7 and J8 Pinout**

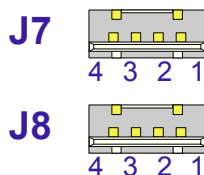

PIN	SIGNAL	FUNCTION	I/O
1	VCC	VCC	--
2	UV0-	Differential USB-	I/O
3	UV0+	Differential USB+	I/O
4	GND	GND	--



Note ...

The USB power supply to each USB connector is protected with a fuse (500 mA) and all the signal lines are EMI-filtered.

2.3.3 Graphics Controller

The CP6012 includes a highly integrated graphics controller ATI ES1000 for connecting the CP6012 to a standard progressive scan monitor. The ATI ES1000 graphics controller provides a 16-bit wide, 533 MHz fast DDR2 memory interface for connecting it to the video memory. This interface is only active when running in internal graphics mode.

Integrated 2D Graphics:

- One CRT controller capable of supporting 64 MB DDR2 video memory running at 533 MHz
- 2D hardware acceleration
- Integrated 350 MHz DAC
- Resolution up to 1600 x 1200 @ 75 Hz
- Optimized for server applications





2.3.3.1 Video Resolution

The ES1000 has an integrated 350 MHz RAMDAC that can directly drive a progressive scan analog monitor up to a resolution of 1600x1200 @ 75 Hz.

Table 2-11: Partial List of Display Modes Supported

DISPLAY MODE	COLOR RESOLUTION VERSUS HORIZONTAL FREQUENCY												
	8-BIT INDEXED				16-BIT				32-BIT				
	60	75	85	100	60	75	85	100	60	75	85	100	
640 x 480	X	X	X	X	X	X	X	X	X	X	X	X	X
800 x 600	X	X	X	X	X	X	X	X	X	X	X	X	X
1024 x 768	X	X	X	X	X	X	X	X	X	X	X	X	X
1280 x 1024	X	X	X	X	X	X	X	X	X	X	--	--	--
1600 x 1200	X	X	--	--	X	X	--	--	--	--	--	--	--

2.3.3.2 CRT Interface and Connector J10

The 15-pin female connector J10 is used to connect a CRT monitor to the CP6012 board.

Figure 2-2: D-Sub CRT Con. J10

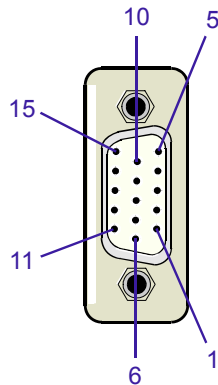

Table 2-12: D-Sub CRT Connector J10 Pinout

PIN	SIGNAL	FUNCTION	I/O
1	Red	Red video signal output	O
2	Green	Green video signal output	O
3	Blue	Blue video signal output	O
13	Hsync	Horizontal sync.	TTL Out
14	Vsync	Vertical sync.	TTL Out
12	Sdata	I ² C data	I/O
15	Sclk	I ² C clock	O
9	VCC	Power +5V, 1.5 A fuse protection	O
5,6,7,8,10	GND	Ground signal	--
4,11	NC	Not connected	--



2.3.4 COM Ports

The CP6012 provides two COM ports, COM1 and COM2. COM1 is available on the front panel as a 9-pin, D-Sub, PC-compatible connector, and is routed to rear I/O. COM2 is only available on the rear I/O module. COM1 and COM2 are fully compatible with the 16550 controller and include a complete set of handshaking and modem control signals, maskable interrupt generation and data transfer of up to 115.2 kB/s. The two COM ports are configured as RS-232.

The following figure and table provide pinout information for the serial port connector J9.

Figure 2-3: Serial Port Con. J9 (COM1) Table 2-13: Serial Port Con. J9 (COM1) Pinout

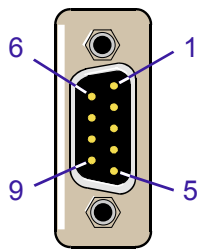

PIN	RS-232 (STANDARD PC)
1	DCD
2	RXD
3	TXD
4	DTR
5	GND
6	DSR
7	RTS
8	CTS
9	RIN

2.3.5 Floppy Drive Interface

The onboard floppy disk controller supports either 5.25 inch or 3.5 inch (1.44 or 2.88 MB) floppy disks. The floppy disk port is only available on the CompactPCI rear I/O interface.





2.3.6 Gigabit Ethernet

The CP6012 board provides four 10Base-T/100Base-TX/1000Base-T Ethernet interfaces based on two Intel® 82571EB Gigabit Ethernet controllers, which are connected to the PCI Express interface. Two Gigabit Ethernet interfaces are available on the front panel. Two additional Gigabit Ethernet interfaces are available on the rear I/O in accordance with the PICMG 2.16 specification.

The Intel® 82571EB Dual Gigabit Ethernet Controller’s architecture is optimized to deliver high performance with the lowest power consumption. The controller’s architecture includes independent transmit and receive queues and a PCI Express interface that maximizes the use of bursts for efficient bus usage.

The Boot from LAN feature is supported.



Note ...

The maximum length of cabling over which the Ethernet transmission can operate effectively depends upon the transceiver in use.

Figure 2-4: Dual Gigabit Ethernet Connector J6A/B

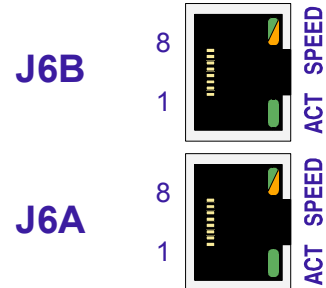

The Ethernet connectors, J6A/B, are realized as RJ45 connectors. The interfaces provide automatic detection and switching between 10Base-T, 100Base-TX and 1000Base-T data transmission (Auto-Negotiation). Auto-wire switching for crossed cables is also supported (Auto-MDI/X).

Table 2-14: Pinouts of J6A/B Based on the Implementation

MDI / STANDARD ETHERNET CABLE						PIN	MDIX / CROSSED ETHERNET CABLE					
10BASE-T		100BASE-TX		1000BASE-T			10BASE-T		100BASE-TX		1000BASE-T	
I/O	SIGNAL	I/O	SIGNAL	I/O	SIGNAL		I/O	SIGNAL	I/O	SIGNAL	I/O	SIGNAL
0	TX+	0	TX+	I/O	BI_DA+	1	I	RX+	I	RX+	I/O	BI_DB+
0	TX-	0	TX-	I/O	BI_DA-	2	I	RX-	I	RX-	I/O	BI_DB-
I	RX+	I	RX+	I/O	BI_DB+	3	0	TX+	0	TX+	I/O	BI_DA+
-	-	-	-	I/O	BI_DC+	4	-	-	-	-	I/O	BI_DD+
-	-	-	-	I/O	BI_DC-	5	-	-	-	-	I/O	BI_DD-
I	RX-	I	RX-	I/O	BI_DB-	6	0	TX-	0	TX-	I/O	BI_DA-
-	-	-	-	I/O	BI_DD+	7	-	-	-	-	I/O	BI_DC+
-	-	-	-	I/O	BI_DD-	8	-	-	-	-	I/O	BI_DC-



Ethernet LED Status

ACT (green): This LED indicates network connection and activity. The LED lights up when network packets are sent or received through the RJ45 port. When this LED is not lit it means that either the computer is not sending or receiving network data or that the cable connection is faulty.

SPEED (green/orange): This LED lights up to indicate a successful 100Base-TX or 1000BASE-T connection. When green it indicates a 100Base-TX connection and when orange it indicates a 1000Base-TX connection. When not lit and the ACT-LED is active, the connection is operating at 10Base-T.

2.3.7 EIDE Interfaces

The CP6012 supports two EIDE interfaces, one for CompactFlash compliant devices and one on the Rear I/O interface. The EIDE interface on the Rear I/O supports up to two devices (one master and one slave). All devices can be used in cylinder head sector (CHS) mode with the BIOS also supporting the logical block addressing (LBA) mode.

2.3.7.1 CompactFlash Socket

To enable flexible flash extension, a CompactFlash (CF) type II socket, J17, is available.

CompactFlash is a very small removable mass storage device. It provides true IDE functionality compatible with the 16-bit ATA/ATAPI-4 interface.

The CompactFlash socket is connected to the primary EIDE port and can be set to master or slave.

The board supports DMA and both CF types (type I and type II). CompactFlash is available in both CF type I and CF type II cards. The Microdrive is a CF type II card.

Access to the CompactFlash socket is restricted if there is a wide heat sink or an onboard HDD installed. In either of these cases, the CF must be installed at the factory and can not be replaced by the customer. If replacement is required, please contact Kontron for further assistance. The following table provides the pinout for the CompactFlash connector J17.

Table 2-15: CompactFlash Connector J17 Pinout

I/O	FUNCTION	SIGNAL	PIN	PIN	SIGNAL	FUNCTION	I/O
--	Ground signal	GND	1	2	D03	Data 3	I/O
I/O	Data 4	D04	3	4	D05	Data 5	I/O
I/O	Data 6	D06	5	6	D07	Data 7	I/O
O	Chip select 0	IDE_CS0	7	8	GND (A10)	--	--
--	--	GND (ATASEL)	9	10	GND (A09)	--	--
--	--	GND (A08)	11	12	GND (A07)	--	--
--	Power 3.3 V	VCC	13	14	GND (A06)	--	--
--	--	GND (A05)	15	16	GND (A04)	--	--
--	--	GND (A03)	17	18	A02	Address 2	O
O	Address 1	A01	19	20	A00	Address 0	O
I/O	Data 0	D00	21	22	D01	Data 1	I/O
I/O	Data 2	D02	23	24	IOCS16	--	O
--	--	NC (CD2)	25	26	NC (CD1)	--	--
I/O	Data 11	D11	27	28	D12	Data 12	I/O
I/O	Data 13	D13	29	30	D14	Data 14	I/O
I/O	Data 15	D15	31	32	IDE_CS1	Chip select 1	O
--	--	NC (VS1)	33	34	IORD	I/O read	O
O	I/O write	IOWR	35	36	WE (VCC)	Write enable	O
I	Interrupt request	INTRQ	37	38	VCC	Power 3.3 V	--
O	Master/Slave	CSEL (GND/pull-up)	39	40	NC (VS2)	--	--
O	Reset	Reset	41	42	IORDY	I/O ready	I
O	Acknowledge	INPACK	43	44	DACK	Data acknowl- edge	I
I/O	Drive active slave present	DASP	45	46	NC (PDIAG)	--	--
I/O	Data 08	D08	47	48	D09	Data 09	I/O
I/O	Data 10	D10	49	50	GND	--	--



2.3.8 Extension Connector J12

The I/O extension connector provides cost-effective and flexible configuration options. To provide flexible configuration of additional low speed PC devices, such as Super I/O, IPMI or CAN controller, the LPC port is connected to the I/O extension connector. The I/O extension interface contains all the signals necessary to connect up to two LPC devices.

If an application requires use of this interface, please contact Kontron for further assistance.

Figure 2-5: Extension Con. J12

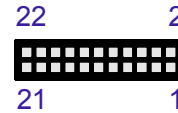

2.3.9 Keyboard/Mouse Interface

The onboard keyboard controller is 8042 software compatible.

The keyboard and mouse port is routed to the CompactPCI rear I/O interface. There is no front I/O connector available. To connect a keyboard, a separate onboard connector is available.

The mouse port is only available on the CompactPCI rear I/O interface.

The CP6012 has a 5-pin male pinrow connector, J21, for the keyboard interface.

Figure 2-6: Keyboard Connector J21

Table 2-16: Keyboard Connector J21 Pinout



PIN	SIGNAL	FUNCTION	I/O
1	KDATA	Keyboard data	I/O
2	--	--	--
3	GND	Ground	--
4	VCC	VCC 5V	--
5	KCLK	Keyboard clock	O



2.3.10 Serial ATA Interface

The CP6012 supports the new Serial ATA technology through the SATA interface. The SATA specification allows for thinner, more flexible cables with lower pin count (only 7 pins, instead of 40 pins as on standard EIDE). The current Serial ATA interface allows up to 150 MB/s data transfer rate, which is faster than the standard Parallel ATA with 100 MB/s (Ultra ATA/100). Both ports are available on the CompactPCI rear I/O interface. A standard SATA HDD can be connected to the CP6012 either via the SATA connector, J22, or using the CP6012-EXT-SATA module connected to the SATA extension connector, J23.

2.3.11 Serial ATA Connector J22

The CP6012 is equipped with a SATA connector, J22, which is used to connect standard HDDs and other SATA devices to the CP6012. This SATA channel can be switched either to the SATA Connector J22 or to the Rear I/O Connector J5 via the BIOS.

Figure 2-7: SATA Connector J22 Table 2-17: SATA Connector J22 Pinout

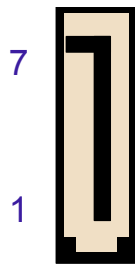

PIN	SIGNAL	FUNCTION	I/O
1	GND	Ground signal	--
2	SATA_TX1+	Differential Transmit +	O
3	SATA_TX1-	Differential Transmit -	O
4	GND	Ground signal	--
5	SATA_RX1-	Differential Receive -	I
6	SATA_RX1+	Differential Receive +	I
7	GND	Ground signal	--



Note ...

System integrators must be aware that if this interface is used, additional free space to the right of the CP6012 board must be available to accommodate the SATA cable and its connector. When the cable is installed, the connector alone will exceed the 4HP width of the board.



2.3.12 2.5" SATA HDD Extension Connectors J23

Boards equipped with a narrow heat sink provide one 12-pin, female SATA extension connector, J23. This connector is used to connect an onboard 2.5" Serial ATA HDD to the CP6012 through the CP6012-EXT-SATA module. For further information on the CP6012-EXT-SATA module, refer to Appendix B.

Figure 2-8: SATA Ext. Con. J23

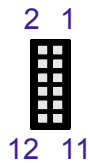
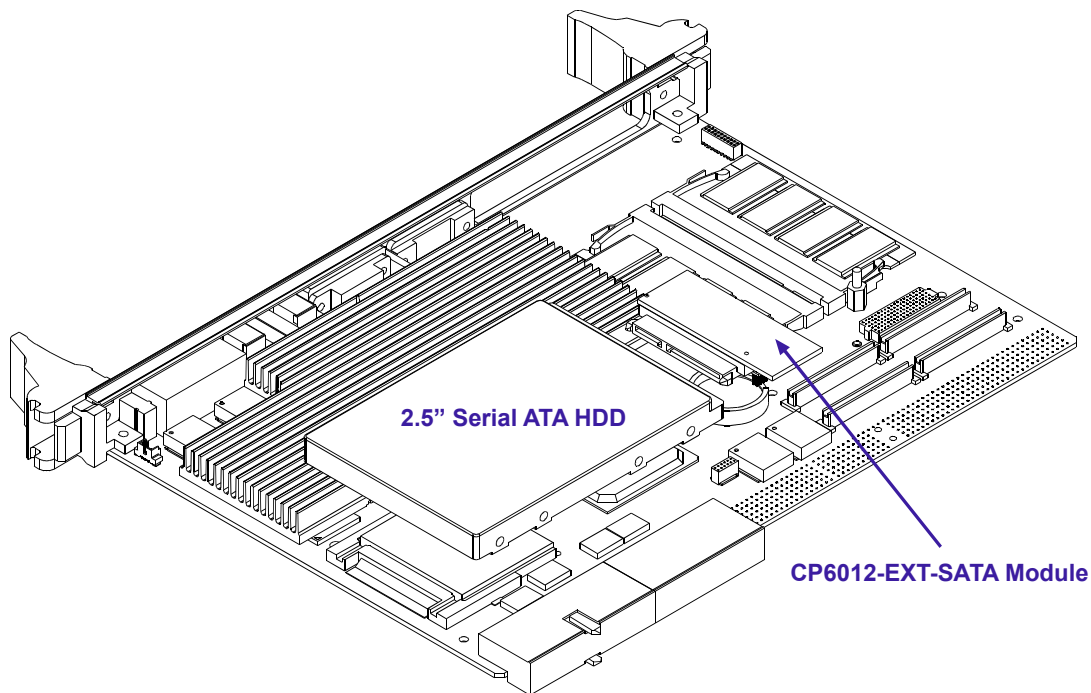

Table 2-18: SATA Extension Connector J23 Pinout

PIN	SIGNAL	FUNCTION	I/O
1	SATA_RX0-	Differential Receive -	I
2	GND	Ground signal	--
3	SATA_RX0+	Differential Receive +	I
4	GND	Ground signal	--
5	GND	Ground signal	--
6	5V	5V power	--
7	SATA_TX0-	Differential Transmit -	O
8	GND	Ground signal	--
9	SATA_TX0+	Differential Transmit +	O
10	GND	Ground signal	--
11	GND	Ground signal	--
12	5V	5V power	--

Figure 2-9: Connecting an Onboard 2.5" SATA HDD to CP6012-EXT-SATA





Note ...

If a wide heat sink is mounted on the CP6012, it is not possible to install a 2.5" HDD on the board.

2.3.13 PMC Interface

For flexible and easy configuration one onboard PMC socket is available. The Jn1 and Jn2 connectors provide the signals for the 32-bit PCI Bus. The 64-bit extension for the PMC interface is supported by the Jn3 connector. User defined I/O signals are supported (Jn4) and are connected to the CompactPCI rear I/O connector J4.

The CP6012 provides only 3.3V PMC PCI signaling environment.

Figure 2-10: PMC Connectors J25, J26, J27 and J28

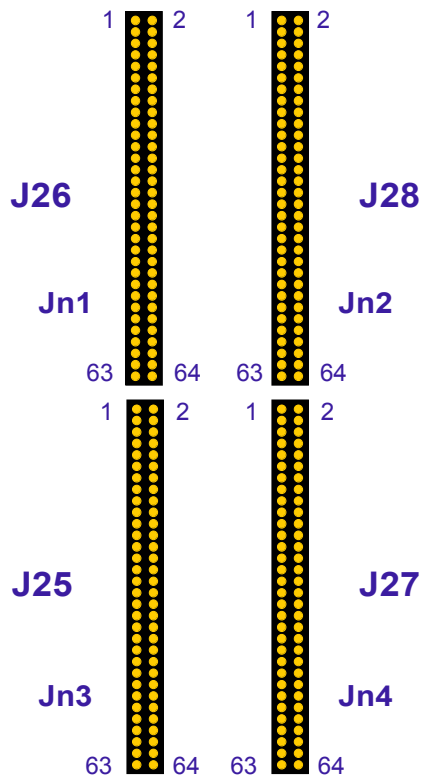

The PMC interface supports the following configurations:

Table 2-19: Onboard PCI Configuration

SIZE	SPEED	INTERFACE
32-bit	33 MHz	PCI
64-bit	33 MHz	PCI
64-bit	66 MHz	PCI

2.3.13.1 PMC Connectors J25, J26, J27 and J28 Pinouts

Table 2-20: PMC Connectors J26 and J28 Pinouts

Jn1 (J26)				Jn2 (J28)			
SIGNAL	PIN	PIN	SIGNAL	SIGNAL	PIN	PIN	SIGNAL
TCK (pull-up)	1	2	-12V	+12V	1	2	TRST# (pull-down)
Ground	3	4	INTA#	TMS (pull-up)	3	4	TDO (NC)
INTB#	5	6	INTC#	TDI (pull-up)	5	6	Ground
BUSMODE1# (NC)	7	8	+5V	Ground	7	8	PCI-RSV (NC)
INTD#	9	10	PCI-RSV (NC)	PCI-RSV (NC)	9	10	PCI-RSV (NC)
Ground	11	12	3V3-AUX (NC)	BUSMODE2# (pull-up)	11	12	+3.3V
CLK	13	14	Ground	RST#	13	14	BUSMODE3# (GND)
Ground	15	16	GNT#	+3.3V	15	16	BUSMODE4# (GND)
REQ#	17	18	+5V	PME# (pull-up)	17	18	Ground
V (I/O)	19	20	AD[31]	AD[30]	19	20	AD[29]
AD[28]	21	22	AD[27]	Ground	21	22	AD[26]
AD[25]	23	24	Ground	AD[24]	23	24	+3.3V
Ground	25	26	C/BE[3]	IDSEL	25	26	AD[23]
AD[22]	27	28	AD[21]	+3.3V	27	28	AD[20]
AD[19]	29	30	+5V	AD[18]	29	30	Ground
V (I/O)	31	32	AD[17]	AD[16]	31	32	C/BE[2]#
FRAME#	33	34	Ground	Ground	33	34	PMC-RSV (NC)
Ground	35	36	IRDY#	TRDY#	35	36	+3.3V
DEVSEL#	37	38	+5V	Ground	37	38	STOP#
PCIXCAP (GND)	39	40	LOCK#	PERR#	39	40	Ground
PCI-RSV (NC)	41	42	PCI-RSV (NC)	+3.3V	41	42	SERR#
PAR	43	44	Ground	C/BE[1]#	43	44	Ground
V (I/O)	45	46	AD[15]	AD[14]	45	46	AD[13]
AD[12]	47	48	AD[11]	M66EN	47	48	AD[10]
AD[09]	49	50	+5V	AD[08]	49	50	+3.3V
Ground	51	52	C/BE[0]#	AD[07]	51	52	PMC-RSV (NC)
AD[06]	53	54	AD[05]	+3.3V	53	54	PMC-RSV (NC)
AD[04]	55	56	Ground	PMC-RSV (NC)	55	56	Ground
V (I/O)	57	58	AD[03]	PMC-RSV (NC)	57	58	PMC-RSV (NC)
AD[02]	59	60	AD[01]	Ground	59	60	PMC-RSV (NC)
AD[00]	61	62	+5V	ACK64#	61	62	+3.3V
Ground	63	64	REQ64#	Ground	63	64	PMC-RSV (NC)

Note ...



The PMC capabilities are detected using the REQ64# and M66EN signals.
 The host controller detects the bus speed via the M66EN signal.
 Low: PCI 33 MHz; High: PCI 66 MHz

Table 2-21: PMC Connectors J25 and J27 Pinouts

Jn3 (J25)				Jn4 (J27)			
SIGNAL	PIN	PIN	SIGNAL	SIGNAL	PIN	PIN	SIGNAL
PCI-RSV (NC)	1	2	Ground	Rear I/O+	1	2	Rear I/O+
Ground	3	4	C/BE[7]	Rear I/O-	3	4	Rear I/O-
C/BE[6]	5	6	C/BE[5]	Rear I/O+	5	6	Rear I/O+
C/BE[4]	7	8	Ground	Rear I/O-	7	8	Rear I/O-
V(I/O)	9	10	PAR64	Rear I/O+	9	10	Rear I/O+
AD[63]	11	12	AD[62]	Rear I/O-	11	12	Rear I/O-
AD[61]	13	14	Ground	Rear I/O+	13	14	Rear I/O+
Ground	15	16	AD[60]	Rear I/O-	15	16	Rear I/O-
AD[59]	17	18	AD[58]	Rear I/O+	17	18	Rear I/O+
AD[57]	19	20	Ground	Rear I/O-	19	20	Rear I/O-
V(I/O)	21	22	AD[56]	Rear I/O+	21	22	Rear I/O+
AD[55]	23	24	AD[54]	Rear I/O-	23	24	Rear I/O-
AD[53]	25	26	Ground	Rear I/O+	25	26	Rear I/O+
Ground	27	28	AD[52]	Rear I/O-	27	28	Rear I/O-
AD[51]	29	30	AD[50]	Rear I/O+	29	30	Rear I/O+
AD[49]	31	32	Ground	Rear I/O-	31	32	Rear I/O-
Ground	33	34	AD[48]	Rear I/O+	33	34	Rear I/O+
AD[47]	35	36	AD[46]	Rear I/O-	35	36	Rear I/O-
AD[45]	37	38	Ground	Rear I/O+	37	38	Rear I/O+
V(I/O)	39	40	AD[44]	Rear I/O-	39	40	Rear I/O-
AD[43]	41	42	AD[42]	Rear I/O+	41	42	Rear I/O+
AD[41]	43	44	Ground	Rear I/O-	43	44	Rear I/O-
Ground	45	46	AD[40]	Rear I/O+	45	46	Rear I/O+
AD[39]	47	48	Signal	Rear I/O-	47	48	Rear I/O-
AD[37]	49	50	Ground	Rear I/O+	49	50	Rear I/O+
Ground	51	52	AD[36]	Rear I/O-	51	52	Rear I/O-
AD[35]	53	54	AD[34]	Rear I/O+	53	54	Rear I/O+
AD[33]	55	56	Ground	Rear I/O-	55	56	Rear I/O-
V(I/O)	57	58	AD[32]	Rear I/O+	57	58	Rear I/O+
PCI-RSV (NC)	59	60	PCI-RSV (NC)	Rear I/O-	59	60	Rear I/O-
PCI-RSV (NC)	61	62	Ground	Rear I/O+	61	62	Rear I/O+
Ground	63	64	PCI-RSV (NC)	Rear I/O-	63	64	Rear I/O-

The signals from the J27 (Jn4) PMC connector are routed to the J4 CompactPCI Rear I/O connector in such a way that they can be used as differential signal pairs. The paired signals are indicated by shading in the table above.

For example, the pathways from pins 1 and 3 are physically routed on the board as a pair to the J4 Rear I/O connector. Thus, they can be used for a differential signal pair.



2.3.14 XMC Interface

For easy and flexible configuration one onboard XMC connector, J15, is available. The XMC connector provides the high-speed signals for a x8 PCI Express interface. For user-defined rear I/O signals, the J27 (Jn4) PMC connector must be used.

Table 2-22: XMC Connector J15 Pinout

PIN	ROW A	ROW B	ROW C	ROW D	ROW E	ROW F
1	PET0p0	PET0n0	3.3V	PET0p1	PET0n1	VPWR
2	GND	GND	TRST#	GND	GND	MRSTI#
3	PET0p2	PET0n2	3.3V	PET0p3	PET0n3	VPWR
4	GND	GND	TCK	GND	GND	MRSTO#
5	PET0p4	PET0n4	3.3V	PET0p5	PET0n5	VPWR
6	GND	GND	TMS	GND	GND	+12V
7	PET0p6	PET0n6	3.3V	PET0p7	PET0n7	VPWR
8	GND	GND	TDI	GND	GND	-12V
9	RFU	RFU	RPS	RFU	RFU	VPWR
10	GND	GND	TDO	GND	GND	GA0
11	PER0p0	PER0n0	MBIST#	PER0p1	PER0n1	VPWR
12	GND	GND	GA1	GND	GND	MPRESENT#
13	PER0p2	PER0n2	3.3V AUX	PER0p3	PER0n3	VPWR
14	GND	GND	GA2	GND	GND	MSDA
15	PER0p4	PER0n4	RPS	PER0p5	PER0n5	VPWR
16	GND	GND	MVMRO	GND	GND	MSCL
17	PER0p6	PER0n6	RFU	PER0p7	PER0n7	RFU
18	GND	GND	RPS	GND	GND	RPS
19	CLK+0	CLK-0	RPS	WAKE#	ROOT0#	RPS

Legend:

RPS Reserved for use by protocol standards

RFU Reserved for future use

VPWR 5V power supply for the XMC module





2.3.15 CompactPCI Interface

The CP6012 supports a flexibly configurable, hot swap CompactPCI interface. In the System Master slot the interface is in the transparent mode, and in the peripheral slot the CompactPCI interface is isolated so that it cannot communicate with the CompactPCI bus. This mode is known as "passive mode".

2.3.15.1 System Master Configuration

In a system slot, the CP6012 can communicate with all other CompactPCI boards through a 64-bit/66 MHz interface.

The CP6012 supports up to seven CompactPCI loads through a passive backplane.

The CP6012 is fully compliant with the PCI Local Bus Specification Rev. 2.2 for 64-bit/66 MHz.

2.3.15.2 Peripheral Master Configuration (Passive Mode)

In a peripheral slot, the board receives power but does not communicate on the CompactPCI bus; all CompactPCI signals are isolated.

In this configuration, the communication is achieved via the two Gigabit Ethernet ports as defined in the PICMG 2.16 specification. In the passive mode the board may be hot-swapped.

2.3.15.3 Packet Switching Backplane (PICMG 2.16)

The CP6012 supports a dual Gigabit Ethernet link port (Node) on the J3 connector in accordance with the CompactPCI Packet Switching Backplane Specification PICMG 2.16, Version 1.0. The two nodes are connected in the chassis via the CompactPCI Packet Switching Backplane to the Fabric slots "A" and "B".

The PICMG 2.16 feature can be used in the system slot and in a peripheral slot.

2.3.15.4 Hot Swap Support

To ensure that a board may be removed and replaced in an operational system, the following additional features are provided:

- Power ramping
- Precharge
- Hot swap control and status register bits
- Automatic interrupt generation whenever a board is about to be removed or replaced
- An LED to indicate that the board may be safely removed

2.3.15.5 Power Ramping

On the CP6012 a special hot swap controller is used to ramp up the onboard supply voltage. This is done to avoid transients on the +3.3V, +5V, +12V and -12V power supplies from the hot swap system. When the power supply is stable, the hot swap controller generates an onboard reset to put the board into a defined state.

2.3.15.6 Precharge

Precharge is provided on the CP6012 by a resistor on each signal line (PCI bus), connected to a +1V reference voltage. If the board is configured in the system master configuration, the reference voltage is disabled.



2.3.15.7 Handle Switch

A microswitch is incorporated in the extractor handle. The status of the handle is included in the onboard logic. The microswitch output is routed to the onboard connector J11.

2.3.15.8 ENUM# Interrupt

In system master configuration the ENUM signal is an input.

2.3.15.9 Hot Swap LED

On the CP6012 a blue HS LED can be switched on or off by software. It may be used, for example, to indicate that the shutdown process is finished and the board is ready for extraction.

2.3.16 CompactPCI Bus Connector

The complete CompactPCI connector configuration comprises five connectors designated as J1 to J5.

Their functions are as follows:

- J1/J2: 64-bit CompactPCI interface with PCI bus signals, arbitration, clock and power
- J3, J4 and J5 have rear I/O interface functionality
- J4 only has optional rear I/O functionality from the PMC module

The CP6012 is designed for a CompactPCI bus architecture. The CompactPCI standard is electrically identical to the PCI local bus. However, these systems are enhanced to operate in industrial environments and to support multiple slots.

2.3.16.1 CompactPCI Connector Keying

CompactPCI connectors support guide lugs to ensure a correct polarized mating. A proper mating is further assured by the use of color coded keys for 3.3V and 5V operation.

Color coded keys prevent inadvertent installation of a 5 V board into a 3.3 V slot and vice versa. The CP6012 board is available as 3.3V or 5V version. Backplane connectors are always keyed according to the signaling (VIO) level. Coding key colors on J1 are defined as follows:

Table 2-23: Coding Key Colors on J1

SIGNALING VOLTAGE	KEY COLOR
3.3V	Cadmium Yellow
5V	Brilliant Blue

To prevent plugging a 5V CP6012 version into a 3.3V V/I/O backplane slot, a blue key is installed in J1.

To prevent plugging the CP6012 into an H.110 backplane slot, a brown key is installed in J4.

Figure 2-11: CPCI Connectors J1-J5

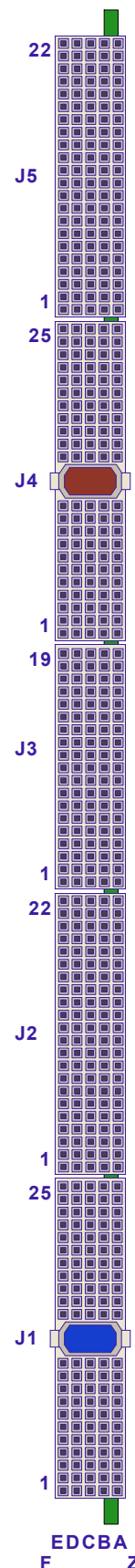

Note:
Pinrow F: GND
Pinrow Z: NC



2.3.16.2 CompactPCI Connectors J1 and J2 Pinouts

The CP6012 is provided with two 2 mm x 2 mm pitch female CompactPCI bus connectors, J1 and J2.

Table 2-24: CompactPCI Bus Connector J1 System Slot Pinout

PIN	Z	A	B	C	D	E	F
25	NC	5V	REQ64#	ENUM#	3.3V	5V	GND
24	NC	AD[1]	5V	V(I/O)	AD[0]	ACK64#	GND
23	NC	3.3V	AD[4]	AD[3]	5V	AD[2]	GND
22	NC	AD[7]	GND	3.3V	AD[6]	AD[5]	GND
21	NC	3.3V	AD[9]	AD[8]	M66EN	C/BE[0]#	GND
20	NC	AD[12]	GND	V(I/O)	AD[11]	AD[10]	GND
19	NC	3.3V	AD[15]	AD[14]	GND	AD[13]	GND
18	NC	SERR#	GND	3.3V	PAR	C/BE[1]#	GND
17	NC	3.3V	IPMB SCL	IPMB SDA	GND	PERR#	GND
16	NC	DEVSEL#	GND	V(I/O)	STOP#	LOCK#	GND
15	NC	3.3V	FRAME#	IRDY#	BDSEL	TRDY#	GND
12-14	Key Area						
11	NC	AD[18]	AD[17]	AD[16]	GND	C/BE[2]#	GND
10	NC	AD[21]	GND	3.3V	AD[20]	AD[19]	GND
9	NC	C/BE[3]#	NC	AD[23]	GND	AD[22]	GND
8	NC	AD[26]	GND	V(I/O)	AD[25]	AD[24]	GND
7	NC	AD[30]	AD[29]	AD[28]	GND	AD[27]	GND
6	NC	REQ0#	GND	3.3V	CLK0	AD[31]	GND
5	NC	BRSVP1A5	BRSVP1B5	RST#	GND	GNT0#	GND
4	NC	IPMB PWR	GND	V(I/O)	INTP	INTS	GND
3	NC	INTA#	INTB#	INTC#	5V	INTD#	GND
2	NC	TCK	5V	TMS	NC	TDI	GND
1	NC	5V	-12V	TRST#	+12V	5V	GND





Table 2-25: CompactPCI Bus Connector J1 Peripheral Slot Pinout

PIN	Z	A	B	C	D	E	F
25	NC	5V	*	ENUM#	3.3V	5V	GND
24	NC	*	5V	V(I/O)	*	*	GND
23	NC	3.3V	*	*	5V	*	GND
22	NC	*	GND	3.3V	*	*	GND
21	NC	3.3V	*	*	M66EN#	*	GND
20	NC	*	GND	V(I/O)	*	*	GND
19	NC	3.3V	*	*	GND	*	GND
18	NC	*	GND	3.3V	*	*	GND
17	NC	3.3V	IPMB SCL	IPMB SDA	GND	*	GND
16	NC	*	GND	V(I/O)	*	*	GND
15	NC	3.3V	*	*	BDSEL	*	GND
12-14	Key Area						
11	NC	*	*	*	GND	*	GND
10	NC	*	GND	3.3V	*	*	GND
9	NC	*	NC	*	GND	*	GND
8	NC	*	GND	V(I/O)	*	*	GND
7	NC	*	*	*	GND	*	GND
6	NC	*	GND	3.3V	*	*	GND
5	NC	BRSVP1A5	BRSVP1B5	*	GND	*	GND
4	NC	IPMB PWR	Healthy#	V(I/O)	INTP	INTS	GND
3	NC	*	*	*	5V	*	GND
2	NC	TCK	5V	TMS	TDO	TDI	GND
1	NC	5V	-12V	TRST#	+12V	5V	GND

**Note ...**

A * indicates that the signal normally present at this pin is disconnected from the CompactPCI bus when the CP6012 is inserted in a peripheral slot.



Table 2-26: 64-bit CompactPCI Bus Connector J2 System Slot Pinout

PIN	Z	A	B	C	D	E	F
22	NC	GA4	GA3	GA2	GA1	GA0	GND
21	NC	CLK6	GND	RSV	RSV	RSV	GND
20	NC	CLK5	GND	RSV	GND	RSV	GND
19	NC	GND	GND	IPMB2_SDA	IPMB2_SCL	IPMB2_Alert	GND
18	NC	RSV	RSV	RSV	GND	RSV	GND
17	NC	RSV	GND	PRST#	REQ6#	GNT6#	GND
16	NC	RSV	RSV	DEG#	GND	RSV	GND
15	NC	RSV	GND	FAL#	REQ5#	GNT5#	GND
14	NC	AD[35]	AD[34]	AD[33]	GND	AD[32]	GND
13	NC	AD[38]	GND	V(I/O)	AD[37]	AD[36]	GND
12	NC	AD[42]	AD[41]	AD[40]	GND	AD[39]	GND
11	NC	AD[45]	GND	V(I/O)	AD[44]	AD[43]	GND
10	NC	AD[49]	AD[48]	AD[47]	GND	AD[46]	GND
9	NC	AD[52]	GND	V(I/O)	AD[51]	AD[50]	GND
8	NC	AD[56]	AD[55]	AD[54]	GND	AD[53]	GND
7	NC	AD[59]	GND	V(I/O)	AD[58]	AD[57]	GND
6	NC	AD[63]	AD[62]	AD[61]	GND	AD[60]	GND
5	NC	C/BE[5]#	64EN#	V(I/O)	C/BE[4]#	PAR64	GND
4	NC	V(I/O)	RSV	C/BE[7]#	GND	C/BE[6]#	GND
3	NC	CLK4	GND	GNT3#	REQ4#	GNT4#	GND
2	NC	CLK2	CLK3	SYSEN#	GNT2#	REQ3#	GND
1	NC	CLK1	GND	REQ1#	GNT1#	REQ2#	GND

Table 2-27: 64-bit CompactPCI Bus Connector J2 Peripheral Slot Pinout

PIN	Z	A	B	C	D	E	F
22	NC	GA4	GA3	GA2	GA1	GA0	GND
21	NC	*	GND	RSV	RSV	RSV	GND
20	NC	*	GND	RSV	GND	RSV	GND
19	NC	GND	GND	IPMB2_SDA	IPMB2_SCL	IPMB2_Alert	GND
18	NC	BRSVP2A18	BRSVP2B18	BRSVP2C18	GND	BRSVP2E18	GND
17	NC	BRSVP2A17	GND	PRST#	*	*	GND
16	NC	BRSVP2A16	BRSVP2B16	DEG#	GND	BRSVP2E16	GND
15	NC	BRSVP2A15	GND	FAL#	*	*	GND
14	NC	*	*	*	GND	*	GND
13	NC	*	GND	V(I/O)	*	*	GND
12	NC	*	*	*	GND	*	GND
11	NC	*	GND	V(I/O)	*	*	GND
10	NC	*	*	*	GND	*	GND
9	NC	*	GND	V(I/O)	*	*	GND
8	NC	*	*	*	GND	*	GND
7	NC	*	GND	V(I/O)	*	*	GND
6	NC	*	*	*	GND	*	GND
5	NC	*	*	V(I/O)	*	*	GND
4	NC	V(I/O)	BRSVP2B4	*	GND	*	GND
3	NC	*	GND	*	*	*	GND
2	NC	*	*	SYSEN#	NC	*	GND
1	NC	*	GND	*	*	*	GND

**Note ...**

A * indicates that the signal normally present at this pin is disconnected from the CompactPCI bus when the CP6012 is inserted in a peripheral slot.



2.3.16.3 CompactPCI Rear I/O Connectors J3-J5 and Pinouts

The CP6012 conducts all I/O signals through the rear I/O connectors J3, J4 and J5. The CP6012 board provides optional rear I/O connectivity for peripherals. All standard PC interfaces are implemented and assigned to the front panel and to the rear I/O connectors J3, and J5.

When the rear I/O module is used, the signals of some of the main board/front panel connectors are routed to the module interface. Thus, the rear I/O module makes it much easier to remove the CPU in the rack as there is practically no cabling on the CPU board.

For the rear I/O feature a special backplane is necessary. The CP6012 with rear I/O is compatible with all standard 6U CompactPCI passive backplanes with rear I/O support.

The CP6012 conducts all I/O signals through the rear I/O connectors J3, J4 and J5.

Table 2-28: CompactPCI Rear I/O Connector J3 Pinout

PIN	Z	A	B	C	D	E	F
19	NC	RIO_VCC	RIO_VCC	RIO_3.3V	RIO_+12V	RIO_-12V	GND
18	NC	LPa_DA+	LPa_DA-	GND	LPa_DC+	LPa_DC-	GND
17	NC	LPa_DB+	LPa_DB-	GND	LPa_DD+	LPa_DD-	GND
16	NC	LPb_DA+	LPb_DA-	GND	LPb_DC+	LPb_DC-	GND
15	NC	LPb_DB+	LPb_DB-	GND	LPb_DD+	LPb_DD-	GND
14	NC	LPa:LINK	LPb:LINK	LPab:CT1	NC	FAN:SENSE2	GND
13	NC	LPa:ACT	LPb:ACT	NC	NC	FAN:SENSE1	GND
12	NC	NC	NC	GND	NC	NC	GND
11	NC	NC	NC	GND	NC	NC	GND
10	NC	USB1:VCC	USB0:VCC	GND	NC	NC	GND
9	NC	USB1:D-	USB1:D+	GND	NC	NC	GND
8	NC	USB0:D-	USB0:D+	GND	NC	NC	GND
7	NC	RIO_3.3V	ID2	ID3	ID4	SPEAKER	GND
6	NC	VGA:RED	VGA:GREEN	VGA:SDA	NC	NC	GND
5	NC	VGA:BLUE	VGA:HSYNC	VGA:VSYNC	VGA:SCL	KB:CLK	GND
4	NC	SP1:RI	SP1:DTR	SP1:CTS	SP1:TX#	KB:DATA	GND
3	NC	SP1:RTS	SP1:RX#	SP1:DSR	SP1:DCD	PS2:DATA	GND
2	NC	SP0:RI	SP0:DTR	SP0:CTS	SP0:TX#	PS2:CLK	GND
1	NC	SP0:RTS	SP0:RX#	SP0:DSR	SP0:DCD	ID1	GND



Warning!

The RIO_XXX signals are power supply **OUTPUTS** to supply the rear I/O module with power. These pins **MUST NOT** be connected to any other power source, either within the backplane itself or within a rear I/O module.

Failure to comply with the above will result in damage to your board.



The following table describes the signals of the J3 connector.

Table 2-29: CompactPCI Rear I/O Connector J3 Signals

SIGNAL	DESCRIPTION
SP0	COM1 Signaling (RS-232)
SP1	COM2 Signaling (RS-232)
VGA	Graphic Signaling
USB0	USB Port Signaling
USB1	USB Port Signaling
KB	PS/2 Keyboard Signaling
PS2	PS/2 Mouse Signaling
SPEAKER	Standard PC Speaker
FAN	Fan Sensoring
LPa	Rear I/O LAN Port B
LPb	Rear I/O LAN Port A



Table 2-30: CompactPCI Rear I/O Connector J4 Pinout

PIN	Z	A	B	C	D	E	F
25	NC	PIM:1	PIM:3	GND	PIM:2	PIM:4	GND
24	NC	PIM:5	PIM:7	GND	PIM:6	PIM:8	GND
23	NC	NC	RIO_VCC	GND	NC	RIO_3.3V	GND
22	NC	PIM:9	PIM:11	GND	PIM:10	PIM:12	GND
21	NC	PIM:13	PIM:15	GND	PIM:14	PIM:16	GND
20	NC	GND	GND	GND	GND	GND	GND
19	NC	PIM:17	PIM:19	GND	PIM:18	PIM:20	GND
18	NC	PIM:21	PIM:23	GND	PIM:22	PIM:24	GND
17	NC	GND	GND	GND	GND	GND	GND
16	NC	PIM:25	PIM:27	GND	PIM:26	PIM:28	GND
15	NC	PIM:29	PIM:31	GND	PIM:30	PIM:32	GND
12-14	Key Area						
11	NC	PIM:33	PIM:35	GND	PIM:34	PIM:36	GND
10	NC	PIM:37	PIM:39	GND	PIM:38	PIM:40	GND
9	NC	GND	GND	GND	GND	GND	GND
8	NC	PIM:41	PIM:43	GND	PIM:42	PIM:44	GND
7	NC	PIM:45	PIM:47	GND	PIM:46	PIM:48	GND
6	NC	GND	GND	GND	GND	GND	GND
5	NC	PIM:49	PIM:51	GND	PIM:50	PIM:52	GND
4	NC	PIM:53	PIM:55	GND	PIM:54	PIM:56	GND
3	NC	GND	GND	GND	GND	GND	GND
2	NC	PIM:57	PIM:59	GND	PIM:58	PIM:60	GND
1	NC	PIM:61	PIM:63	GND	PIM:62	PIM:64	GND

The signals from the J4 CompactPCI Rear I/O connector are routed to the J27 (Jn4) PMC connector in such a way that they can behave as differential signal pairs. The paired signals are indicated by shading in the table above.

For example, the pathways from pins A1 and B1 are physically routed on the board as a pair to the J27 (Jn4) PMC connector. Thus, they can be used for a differential signal pair.



Warning!

The RIO_XXX signals are power supply **OUTPUTS** to supply the rear I/O module with power. These pins **MUST NOT** be connected to any other power source, either within the backplane itself or within a rear I/O module.

Failure to comply with the above will result in damage to your board.

Table 2-31: CompactPCI Rear I/O Connector J5 Pinout

PIN	Z	A	B	C	D	E	F
22	NC	IDE:ACT#/RSV	IDE:CS1#	GND	IDE:CS0#	BATT (3.0V)	GND
21	NC	IDE:A2	IDE:A0	GND	IDE:A1	IDE:DIAG#	GND
20	NC	IDE:IOCS16#	IDE:IRQ	GND	IDE:ACK#	IDE:IORDY	GND
19	NC	IDE:IOR#	IDE:IOW#	GND	IDE:REQ	IDE:D15	GND
18	NC	IDE:D0	IDE:D14	GND	IDE:D1	IDE:D13	GND
17	NC	IDE:D2	IDE:D12	GND	IDE:D3	IDE:D11	GND
16	NC	IDE:D4	IDE:D10	GND	IDE:D5	IDE:D9	GND
15	NC	IDE:D6	IDE:D8	GND	IDE:D7	IDE:RESET#	GND
14	NC	FD: DSKCHG#	FD: HDSEL#	GND	FD: RDATA#	FD: WRPROT#	GND
13	NC	FD: TRK0#	FD: WGate#	GND	FD: WDATA#	FD: STEP#	GND
12	NC	FD: DIR#	FD: MTR1#	GND	FD: DSEL0#	FD: DSEL1#	GND
11	NC	FD: MTR0#	FD: INDEX#	GND	FD: FDEDIN#	FD: DENSEL#	GND
10	NC	FD:MSEN0	FD:MSEN1	GND	SMB:SDA	SMB:SCL	GND
9	NC	GND	GND	GND	GND	GND	GND
8	NC	NC	NC	GND	NC	NC	GND
7	NC	GND	GND	GND	GND	GND	GND
6	NC	NC	NC	GND	NC	NC	GND
5	NC	GND	GND	GND	GND	GND	GND
4	NC	HT1:TX+	HT1:TX-	GND	HT1:RX+	HT1:RX-	GND
3	NC	GND	GND	GND	GND	GND	GND
2	NC	HT0:TX+	HT0:TX-	GND	HT0:RX+	HT0:RX-	GND
1	NC	GND	GND	GND	GND	GND	GND

The following table describes the signals of the J5 connector.

Table 2-32: CompactPCI Rear I/O Connector J5 Signals

SIGNAL	DESCRIPTION
HT0	SATA Port 0 Signaling
HT1	SATA Port 1 Signaling
SMB	System Management Bus Signaling
FD	Floppy Disk Signaling
IDE	Secondary Hard Disk Drive Channel Signaling



2.3.16.4 Rear I/O Configuration

Rear I/O interfaces are only available on the rear I/O version of the board. The following table provides an overview of the interfaces and a short description.

Table 2-33: Rear I/O Configuration

INTERFACES	DESCRIPTION
Ethernet	Gigabit Ethernet signals are available on the rear I/O interface (PICMG 2.16 pinout).
VGA CRT	Two panels can be connected to the CP6012 simultaneously, one to the front and one to the rear I/O. However, both panels display the same contents.
COM1 and COM2	Only one interface may be used (rear I/O or front I/O) for COM 1.
Keyboard/Mouse	The keyboard interface is available onboard and via the rear I/O. The combination of the onboard and the rear I/O is not supported. The mouse interface is only available via the rear I/O.
USB	Two USB interfaces are available via the rear I/O. The USB power comes from the baseboard and it is protected by a self-resettable fuse.
Secondary EIDE	The secondary EIDE interface is available only on the rear I/O.
Floppy	The floppy interface is only available via the rear I/O.
SATA	The SATA0 and SATA1 interfaces are available onboard or on the rear I/O. Sharing the onboard SATA with the rear I/O SATA is not permitted.
PMC Rear I/O	The PMC Rear I/O pinout is optimized to connect the Kontron SCSI PMC board (PMC 261). This module provides SCSI rear I/O support. Other PMC modules with rear I/O functionality can also be used on the CP6012.



2.4 Intelligent Platform Management Interface

2.4.1 Technical Background of IPMI

The CP6012 has been designed to support the "Intelligent Platform Management Interface" (IPMI) subsystem which is another step in providing high availability platforms. Intelligent Platform Management means monitoring the health of the entire system beyond the confines of the board itself, so that the status of the complete system is available to be used, for example, for control and intervention purposes. A range of variables is monitored on every board, to provide information on the system status, e.g. voltages, temperature, powergood signals, reset signals etc. Additionally, the IPMI Baseboard Management Controller can intervene, regulating the operating status of the system by controlling fans, shutting down systems and generating alarm signals as and when fault conditions occur. These fault conditions are simultaneously logged in non-volatile memory for analysis and for fault recovery. IPMI also defines a protocol (software stack) for exchanging the status messages of the board, so that "IPMI ready" boards/systems from different suppliers can be monitored. In addition, a clear interface (registers, addresses etc.) is defined for guaranteeing that System Management software can work with every compliant IPMI hardware.

The electrical interconnection between IPMI capable boards is an I²C interface (IPMB). On CompactPCI systems, this interface is provided on IPMI prepared backplanes and guarantees the data path between the boards.

The devices which handle the measurements and the protocol stack are microcontrollers known as Baseboard Management Controller (BMC), and Peripheral Management Controller (PM) or Satellite Management Controller (SMC). The entire IPMI protocol is controlled by the BMC. On the CP6012, the IPMI controller can be configured to act as BMC or PM/SMC.

The interface between the system controller CPU's System Management software and the Baseboard Management Controller is realized as a keyboard controller style interface (KCS) which can be found in the board's I/O space.



2.4.2 IPMI Glossary

BMC	Baseboard Management Controller In a CompactPCI chassis, there can be only one BMC present.
BT	Block Transfer Interface
SEL	System Event Log The SEL repository is present only in the BMC.
SDR	Sensor Data Record
SDRR	Sensor Data Record Repository The SDRR is only present in the BMC. Normally, the SDRR contains all sensor records of the chassis.
IPMI	Intelligent Platform Management Interface
IPMB	Intelligent Platform Management Bus
KCS	Keyboard Controller Style
FRU	Field Replaceable Units A FRU is available in BMC or satellite mode.
PM	Peripheral Management Controller The PM is a microcontroller located on the peripheral board in a Compact-PCI system and handles the measurements and the protocol stack.
SMS	System Management Software
SMC	Satellite Management Controller Slave mode of BMC



2.4.3 IPMI Implementation on the CP6012

This product fully supports the Intelligent Platform Management Interface 1.5 and PICMG 2.9 R1.0 specifications. It uses a 16-bit micro-controller (Hitachi H8/2145) to run an IPMI firmware. All the information collected by the IPMI controller is then accessible by software through a keyboard-style Interface (see IPMI-Intelligent Platform Management Interface Specification V 1.5 for more information).

Features of the IPMI implemented on the CP6012:

- Compliant with IPMI specification, revision 1.5
- Compliant with PICMG 2.9 specification
- Firmware designed and specially made for CompactPCI implementation
- KCS SMS interface with interrupt support
- I/O address map (0xCA2 - 0xCA3 and 0xCA4 - 0xCA5)
- Dual Port IPMB configurable as two independent channels or in redundant mode
- Comprehensive set of threshold and discrete sensors
- Sensor threshold fully configurable
- Complete IPMI watchdog functionality (reset, power down, power cycle)
- Complete SEL, SDRR and FRU functionality
- Master Read/Write I²C support for external I²C communication devices (FRU, EEPROM, FAN)
- FRU data capacity: 1KB
- BMC or SMC operation mode can be configured via BIOS
- Firmware fully customizable according to the customer needs
- Interoperable with other IPMI solutions
- XMC module support (presence, FRU data access)
- Firmware Hub Flash selection
- Boot order configuration
- POST code reading
- Geographic address
- Payload power control
- Two fan speed inputs
- Hot swap LED
- Hot swap controller
- Board reset



2.4.3.1 Sensors Implemented on the CP6012

The IPMI firmware includes many sensors. The CP6012 implements several sensors, such as sensors for voltage and pass/fail type signal monitoring. Each sensor's description is built in the IPMI firmware and is accessible to the SMS.

The following tables indicate the signals implemented on the CP6012.

Table 2-34: Processor and Chipset Supervision

FUNCTION	DESCRIPTION
PCI reset	Status of PCI reset signal
System reset	Status of reset input to chipset
Chipset sleep state	Status of chipset sleep state
Critical interrupt: NMI	Status of processor NMI line
Critical interrupt: SMI	Status of processor SMI line

Table 2-35: CompactPCI Sensors

FUNCTION	DESCRIPTION
System slot detection	Indicates board is in a system slot
Backplane power supply FAIL	Status of power supply
Backplane power supply DERATE	Status of power supply
Backplane HEALTHY	Status of board health
Backplane BDSEL	Status of board select input signal
Hot Swap LED	Controls the front panel hot swap LED
Hot Swap handle	Status of hot swap handle

Table 2-36: Onboard Power Supply Supervision

FUNCTION	DESCRIPTION
Power supply power good	Status of various onboard supply voltages
Hot swap early power good	Status of hot swap early supply voltages
Hot swap controller	Controls the various board input power voltages

Table 2-37: Reset Control

FUNCTION	DESCRIPTION
RTC reset	Resets the RTC controller
Board reset	Resets the complete board

Table 2-38: Onboard Voltage Sensors

FUNCTION	PRECISION	DESCRIPTION
Voltage 5V	1%	Board 5V supply
Voltage 3.3V	1%	Board 3.3V supply
Voltage IPMI 5V	1%	IPMI 5V supply
Voltage 1.5V	1%	Board 1.5V supply
Voltage 1.8V	1%	Board 1.8V supply
Voltage 0.9V	1%	DDR termination supply
Voltage battery	1%	Board RTC battery

Table 2-39: Temperature Sensors

FUNCTION	DESCRIPTION
Processor temperature	Current board temperature under processor
Board temperature	Current board temperature
MCH temperature	MCH die temperature
CPU temperature control signal	Indicates a CPU overtemperature event (DIE temperature)
Board temperature control signal	Indicates a board overtemperature event
CPU overtemperature	Indicated a catastrophic cooling failure CPU temperature > 125°C
CPU internal thermal monitor	Status of the internal thermal monitor

Table 2-40: Fan Sense Sensors

FUNCTION	DESCRIPTION
Fan sense I	Fan tachometer input
Fan sense II	Fan tachometer input

2.4.4 Data Repositories

All the data gathered by the BMC is stored in a non-volatile memory, providing the possibility to obtain information about working conditions and failure situations.



This page has been intentionally left blank.





Chapter **3**

Installation



This page has been intentionally left blank.



3. Installation

The CP6012 has been designed for easy installation. However, the following standard precautions, installation procedures, and general information must be observed to ensure proper installation and to preclude damage to the board, other system components, or injury to personnel.

3.1 Safety Requirements

The following safety precautions must be observed when installing or operating the CP6012. Kontron assumes no responsibility for any damage resulting from failure to comply with these requirements.



Warning!

Due care should be exercised when handling the board due to the fact that the heat sink can get very hot. Do not touch the heat sink when installing or removing the board.

In addition, the board should not be placed on any surface or in any form of storage container until such time as the board and heat sink have cooled down to room temperature.



Caution!

If your board type is not specifically qualified as being hot swap capable, switch off the CompactPCI system power before installing the board in a free CompactPCI slot. Failure to do so could endanger your life or health and may damage your board or system.



Note...

Certain CompactPCI boards require bus master and/or rear I/O capability. If you are in doubt whether such features are required for the board you intend to install, please check your specific board and/or system documentation to make sure that your system is provided with an appropriate free slot in which to insert the board.



ESD Equipment!

This CompactPCI board contains electrostatically sensitive devices. Please observe the necessary precautions to avoid damage to your board:

- Discharge your clothing before touching the assembly. Tools must be discharged before use.
- Do not touch components, connector-pins or traces.
- If working at an anti-static workbench with professional discharging equipment, please do not omit to use it.



3.2 CP6012 Initial Installation Procedures

The following procedures are applicable only for the initial installation of the CP6012 in a system. Procedures for standard removal and hot swap operations are found in their respective chapters.

To perform an initial installation of the CP6012 in a system proceed as follows:

1. Ensure that the safety requirements indicated Chapter 3.1 are observed.



Warning!

Failure to comply with the instruction above may cause damage to the board or result in improper system operation.

2. Ensure that the board is properly configured for operation in accordance with application requirements before installing. For information regarding the configuration of the CP6012 refer to Chapter 4. For the installation of CP6012 specific peripheral devices and rear I/O devices refer to the appropriate chapters in Chapter 3.



Warning!

Care must be taken when applying the procedures below to ensure that neither the CP6012 nor other system boards are physically damaged by the application of these procedures.

3. To install the CP6012 perform the following:
 1. Ensure that no power is applied to the system before proceeding.



Warning!

When performing the next step, **DO NOT** push the board into the backplane connectors. Use the ejector handles to seat the board into the backplane connectors.

2. Carefully insert the board into the slot designated by the application requirements for the board until it makes contact with the backplane connectors.
 3. Using both ejector handles, engage the board with the backplane. When the ejector handles are locked, the board is engaged.
 4. Fasten the two front panel retaining screws.
 5. Connect all external interfacing cables to the board as required.
 6. Ensure that the board and all required interfacing cables are properly secured.
4. The CP6012 is now ready for operation. For operation of the CP6012, refer to appropriate CP6012 specific software, application, and system documentation.



Warning!

During power-up, the 3.3 V input power supply must be able to provide a minimum peak current of 10 A to the CP6012. This applies for each CP6012 in a given system.

Failure to comply with the instruction above may result in damage to or improper operation of the CP6012.



3.3 Standard Removal Procedures

To remove the board proceed as follows:

1. Ensure that the safety requirements indicated in Chapter 3.1 are observed. Particular attention must be paid to the warning regarding the heat sink!



Warning!

Care must be taken when applying the procedures below to ensure that neither the CP6012 nor system boards are physically damaged by the application of these procedures.

2. Ensure that no power is applied to the system before proceeding.
3. Disconnect any interfacing cables that may be connected to the board.
4. Unscrew the front panel retaining screws.



Warning!

Due care should be exercised when handling the board due to the fact that the heat sink can get very hot. Do not touch the heat sink when changing the board.

5. Disengage the board from the backplane by first unlocking the board ejection handles and then by pressing the handles as required until the board is disengaged.
6. After disengaging the board from the backplane, pull the board out of the slot.
7. Dispose of the board as required.

3.4 Hot Swap Procedures

The CP6012 is designed for hot swap operation. When installed in the system slot it is capable of supporting peripheral board hot swapping. When installed in a peripheral slot, its hot swap capabilities depend on the type of backplane in use and the system controller's capabilities. The reason for this being that communications with the system controller requires either front panel Ethernet I/O or use of a packet switching backplane. In any event, hot swap is also a function of the application running on the CP6012.

3.4.1 System Master Hot Swap

Hot swapping of the CP6012 itself when used as the system controller is possible, but will result in any event in a cold start of the CP6012 and consequently a reinitialization of all peripheral boards. Exactly what transpires in such a situation is a function of the application and is not addressed in this manual. The user must refer to appropriate application documentation for applicable procedures for this case. In any event, the safety requirements above must be observed.



3.4.2 Peripheral Hot Swap Procedure

This procedure assumes that the board to be hot swapped has undergone an initial board installation and is already installed in an operating system, and that the system supports hot swapping of the board.

To hot swap the CP6012 proceed as follows:

1. Ensure that the safety requirements indicated in Chapter 3.1 are observed. Particular attention must be paid to the warning regarding the heat sink!



Warning!

Care must be taken when applying the procedures below to ensure that neither the CP6012 nor other system boards are physically damaged by the application of these procedures.

2. Unlock both board ejection handles ensuring that the bottom handle has activated the hot swap switch (this occurs with a very small amount of movement of the handle).



Note ...

What transpires at this time is a function of the application. If hot swap is supported by the application, then the blue HS LED should light up after a short time period. This indicates that the system has recognized that the CP6012 is to be hot swapped and now indicates to the operator that hot swapping of the CP6012 may proceed.

If the blue HS LED does not light up after a short time period, either the system does not support hot swap or a malfunction has occurred. In this event, the application is responsible for handling this situation and must provide the operator with appropriate guidance to remedy the situation.

3. After approximately 1 to 15 seconds, the blue HS LED should light up. If the LED lights up, proceed with the next step of this procedure. If the LED does not light up, refer to appropriate application documentation for further action.
4. Disconnect any interfacing cables that may be connected to the board.
5. Unscrew the front panel retaining screws.



Warning!

Due care should be exercised when handling the board due to the fact that the heat sink can get very hot. Do not touch the heat sink when changing the board.

6. Using the ejector handles, disengage the board from the backplane and carefully remove it from the system.
7. Dispose of the “old” board as required observing the safety requirements indicated in Chapter 3.1.
8. Obtain the replacement CP6012 board.



Warning!

When performing the next step, **DO NOT** push the board into the backplane connectors. Use the ejector handles to seat the board into the backplane connectors.



- Carefully insert the “new” board into the “old” board slot until it makes contact with the backplane connectors.

**Warning!**

During power-up, the 3.3 V input power supply must be able to provide a minimum peak current of 10 A to the CP6012. This applies for each CP6012 in a given system.

Failure to comply with the above warning may result in damage to or improper operation of the CP6012.

- Using both ejector handles, engage the board with the backplane. When the ejector handles are locked, the board is engaged.
- Fasten the front panel retaining screws.
- Connect all required interfacing cables to the board. Hot swap of the CP6012 is now complete.

3.5 Installation of CP6012 Peripheral Devices

The CP6012 is designed to accommodate a variety of peripheral devices whose installation varies considerably. The following chapters provide information regarding installation aspects and not detailed procedures.

3.5.1 CompactFlash Installation

The CompactFlash socket supports all available CompactFlash ATA cards type I and type II with 3.3V.

**Note ...**

The CP6012 does not support removal and reinsertion of the CompactFlash storage card while the board is in a powered-up state. Connecting the CompactFlash cards while the power is on, which is known as “hot plugging”, may damage your system.

**Note ...**

The easiest way to remove the CompactFlash card is to affix a wide piece of adhesive tape to the top side, then pull it out and afterwards remove the tape.

If a 2.5" HDD is installed on the CP6012 or the CP6012 comes with a wide heat sink, the CompactFlash card is not customer-replaceable. If it is necessary to replace the CompactFlash card, please contact Kontron for further assistance.

3.5.2 USB Device Installation

The CP6012 supports all USB Plug and Play computer peripherals (e.g. keyboard, mouse, printer, etc.).

**Note ...**

All USB devices may be connected or removed while the host or other peripherals are powered up.



3.5.3 Rear I/O Device Installation

For physical installation of rear I/O devices, refer to the documentation provided with the device itself.



Note ...

It is strongly recommended to use COM1 only on the front or rear I/O panel.

3.5.4 Battery Replacement

The lithium battery must be replaced with an identical battery or a battery type recommended by the manufacturer. Suitable batteries include the VARTA CR2025 and PANASONIC BR2020.



Note ...

The user must be aware that the battery's operational temperature range is less than that of the CP6012's storage temperature range.

For exact range information, refer to the battery manufacturer's specifications.



Note ...

Care must be taken to ensure that the battery is correctly replaced.

The battery should be replaced only with an identical or equivalent type recommended by the manufacturer.

Dispose of used batteries according to the manufacturer's instructions.

The typical life expectancy of a 170 mAh battery (VARTA CR2025) is 5 - 6 years with an average on-time of 8 hours per working day at an operating temperature of 30°C. However, this typical value varies considerably because the life expectancy is dependent on the operating temperature and the standby time (shutdown time) of the system in which it operates.

To ensure that the lifetime of the battery has not been exceeded it is recommended to exchange the battery after 4 - 5 years.

3.5.5 Hard Disk Installation

The following information pertains to hard disks which may be connected to the CP6012 via normal cabling. SATA devices can be directly connected to the board. PATA devices can only be connected to the board through a Rear I/O module.

To install a hard disk, it is necessary to perform the following operations in the given order:

1. Install the hardware.



Warning!

The incorrect connection of power or data cables may damage your hard disk unit and/or CP6012 board.

**Note ...**

Some symptoms of incorrectly installed HDDs are:

- Device on a SATA channel does not spin up: check power cables and cabling. May also result from a bad power supply or SATA drive. The SATA connector on the CP6012 provides only a data connection. The power for this device must be supplied by a separate connector. For further information, refer to the respective documentation of the device.
- Hard Disk Drive Fail message at boot-up: may be a bad cable or lack of power going to the drive.

**Note ...**

If a wide heat sink is mounted on the CP6012, it is not possible to install a 2.5" HDD on the board.

2. Initialize the software necessary to run the chosen operating system.

The following table indicates the ATA channel routing:

Table 3-1: ATA Channel Routing

CHANNEL	DEFAULT	ORDER OPTION
PATA0	Onboard CompactFlash socket	Not available
PATA1	Rear I/O Module	Not available
SATA0	Rear I/O Module	Also available for onboard SATA HDDs
SATA1	Rear I/O Module (also switchable to the onboard SATA connector J22 via BIOS)	Not available

3.6 Software Installation

The installation of the Ethernet and all other onboard peripheral drivers is described in detail in the relevant Driver Kit files.

Installation of an operating system is a function of the OS software and is not addressed in this manual. Refer to appropriate OS software documentation for installation.

**Note ...**

Users working with pre-configured operating system installation images for Plug and Play compliant operating systems, for example Windows® 95/98/ME, Windows® 2000, Windows® XP, Windows® XP Embedded, must take into consideration that the stepping and revision ID of the chipset and/or other onboard PCI devices may change. Thus, a re-configuration of the operating system installation image deployed for a previous chipset stepping or revision ID is in most cases required. The corresponding operating system will detect new devices according to the Plug and Play configuration rules.



This page has been intentionally left blank.





Chapter

4

Configuration



This page has been intentionally left blank.





4. Configuration

4.1 Jumper Description

4.1.1 Clearing BIOS CMOS Setup

If the system does not boot (due to, for example, the wrong BIOS configuration or wrong password setting), the CMOS setting may be cleared by using the solder jumper JP4.

Procedure for clearing CMOS setting:

The system is booted with the jumper in the new, closed position, then powered down again. The jumper is reset back to the normal position, then the system is rebooted again.

Table 4-1: Clearing BIOS CMOS Setup

JP4	DESCRIPTION
<i>Open</i>	<i>Normal boot using the CMOS settings</i>
Closed	Clear the CMOS settings and use the default values (Fail Safe)

The default setting is indicated by using italic bold.

4.1.2 Shorting Chassis GND (Shield) to Logic GND

The front panel and the front panel connectors are isolated from the logic ground by means of capacitors. If it is necessary to connect the logic GND with the chassis GND, this should be done on the backplane, not on the board itself (see the PICMG CompactPCI Specification 2.0 R3.0, section 3.6).

For further information, refer to the *Kontron CompactPCI Backplane Manual* on the Kontron web site.



4.1.3 BIOS Firmware Hub Flash Configuration

BIOS Firmware Hub Flash configuration means that there are two chips for the BIOS on the CP6012 board. One chip is intended to provide a backup in the event that the other gets corrupted. If the primary BIOS is corrupted due to physical damage or a faulty Flash upgrade, the 2nd Flash can be selected either via the Board Management Controller or the jumper J19, and the system can boot from it.

Table 4-2: BIOS Firmware Hub Flash Configuration

J19	DESCRIPTION
<i>Open</i>	<i>Standard FWH is selected</i>
Closed	Redundant FWH is selected

The default setting is indicated by using italic bold.

4.1.4 M66EN Configuration

The CP6012 can operate at 66 MHz on the CPCI interface. If the jumper J20 is set, the frequency is reduced to 33 MHz.

Table 4-3: M66EN Configuration

J20	DESCRIPTION
<i>Open</i>	<i>PCI speed capability is driven from the backplane</i>
Closed	PCI 33 MHz

The default setting is indicated by using italic bold.



4.2 Interrupts

The CP6012 board uses the standard AT IRQ routing (8259 controller).

This interrupt routing is the default, but can be modified via the BIOS.

Table 4-4: Interrupt Setting

IRQ	PRIORITY	STANDARD FUNCTION
IRQ0	1	System Timer
IRQ1	2	Keyboard Controller
IRQ2	--	Input of the second IRQ controller (IRQ8-IRQ15)
IRQ3	11	COM2
IRQ4	12	COM1
IRQ5	13	Watchdog
IRQ6	14	Floppy Disk Controller
IRQ7	15	Board Management Controller
IRQ8	3	System Real Time Clock
IRQ9	4	PCI or APIC
IRQ10	5	PCI
IRQ11	6	PCI
IRQ12	7	PCI or PS/2 mouse
IRQ13	8	Coprocessor error
IRQ14	9	Primary hard disk (CompactFlash)
IRQ15	10	Secondary hard disk
NMI		Watchdog



Warning!

IRQ5 should normally have only **one** source enabled, otherwise improper system operation may result.

If more than one source is required to be enabled, contact Kontron's Technical Support before implementing the IRQs.

For events that are not time critical, such as ENUM, DERATE, etc., polling should be considered instead of using an IRQ.



4.3 Onboard PCI Interrupt Routing

The 6300ESB provides up to 12 PCI interrupt inputs. The table below describes the connection of these IRQ signals.

For more information, refer to the INTEL 6300ESB data sheet.

Table 4-5: PCI Interrupt Routing

6300ESB IRQ INPUT	PCI DEVICE	FUNCTION INTERNAL 6300ESB
PIRQA	Free	USB A controller
PIRQB	Free	SMBUS
PIRQC	Free	SATA
PIRQD	Free	USB B controller
PIRQE	VGA	Free
PIRQF	Free	Free
PIRQG	Free	Free
PIRQH	Free	USB 2.0 controller
PCIXIRQ0	PMC INTA / CPCI	Free
PCIXIRQ1	PMC INTB / CPCI	Free
PCIXIRQ2	PMC INTC / CPCI	Free
PCIXIRQ3	PMC INTD / CPCI	Free

For more information, refer to the INTEL 6300ESB data sheet.





4.4 Memory Map

The CP6012 board uses the standard AT ISA memory map.

4.4.1 Memory Map for the 1st Megabyte

The following table sets out the memory map for the first megabyte:

Table 4-6: Memory Map for the 1st Megabyte

MEMORY RANGE	SIZE	FUNCTION
0xE0000 – 0xFFFFF	128 k	BIOS implemented in FWH Reset vector 0xFFFF0
0xD0000 – 0xDFFFF	64 k	Free
0xCC000 – 0xCFFFF	16 k	Free
0xC0000 – 0xCBFFF	48 k	BIOS on the optional VGA card.
0xA0000 – 0xBFFFF	128 k	Normally used as video RAM as follows: CGA video: 0xB8000-0xBFFFF Monochrome video: 0xB0000-0xB7FFF EGA/VGA video: 0xA0000-0xAFFFF
0x000000 – 0x9FFFF	640 k	DOS reserved memory space



4.4.2 I/O Address Map

The following table sets out the memory map for the I/O memory. The gray shaded table cells indicate CP6012-specific registers. The blue shaded table cells indicate BMC-specific registers.

Table 4-7: I/O Address Map

ADDRESS	DEVICE
000,00F	DMA Controller #1
020,021	Interrupt Controller #1
022,02D	Reserved
02E,02F	Super I/O
040,043	Timer
060,063	Keyboard Interface
070,071	RTC Port
080	BIOS POST Code
081,08F	DMA Page Register
0A0,0B0	Interrupt Controller #2
0C0,0DF	DMA Controller #2
0E0,0EF	Reserved
0F0,0FF	Math Coprocessor
170,17F	Hard Disk Secondary
1F0,1FF	Hard Disk Primary
19C	BMC Configuration Register
19F	BMC Interrupt Configuration Register
280	BIOS Boot Order Control Register
281	Reserved
282	Watchdog Timer Control Register
283	Geographic Addressing Register
284	Hardware and Logic Revision Index Register
285	CPCI Reset Status Register
286	I/O Status Register
287	I/O Configuration Register
288	Board ID Register
289	Board Interrupt Configuration Register
28A	Hot Swap Status Register
28B,28C	Reserved
28D	Board-Specific Led Control Register
28E	Reserved
28F	Delay Timer Control/Status Register
2F8,2FF	Serial Port COM2
378,37F	Parallel Printer Port LPT1
3F0,3F7	Floppy Disk
3F8,3FF	Serial Port COM1
CA2,CA3	IPMI SMS KCS Interface
CA4,CA5	IPMI MSM KCS Interface
A00,AFF	Super I/O Power Management Register



4.5 CP6012-Specific Registers

The following registers are special registers which the CP6012 uses to watch the onboard hardware special features and the CompactPCI control signals.

Normally, only the system BIOS uses these registers, but they are documented here for application use as required.



Note ...

Take care when modifying the contents of these registers as the system BIOS may be relying on the state of the bits under its control.

4.5.1 BIOS Boot Order Control Register

The BIOS Boot Order Control Register is used to set the BIOS boot order. This register is read only and can be configured only by the BMC controller.

Table 4-8: BIOS Boot Order Control Register

REGISTER NAME		BIOS BOOT ORDER CONTROL REGISTER							SIZE		
ADDRESS		0x280							8 bits		
BIT POSITION		MSB	7	6	5	4	3	2	1	0	LSB
CONTENT		Res.	Res.	Res.	Res.	BOOT3	BOOT2	BOOT1	BOOT0		
DEFAULT		0	0	0	0	0	0	0	0		
ACCESS		R	R	R	R	R	R	R	R		
BIT	NAME	DESCRIPTION/FUNCTION									
7 - 4	Res.	Reserved									
3 - 0	BOOT[3:0]	BIOS boot order settings: 0000 Boot order is according to BIOS setup (see note below) 0001 Next boot order: FDD 0010 Next boot order: HDD 0011 Next boot order: CD-ROM 0100 Next boot order: Network									



Note ...

The BIOS Boot Order Control Register is set to the default values by power-on reset, not by PCI reset. The BIOS boot order can also be set in the BIOS.



4.5.2 Watchdog Timer Control Register

The CP6012 has one Watchdog Timer provided with a programmable timeout ranging from 125 msec to 256 sec. Failure to strobe the Watchdog Timer within a set time period results in a system reset, NMI or an interrupt. The NMI and interrupt mode can be configured via the Board Interrupt Configuration Register (0x289).

There are four possible modes of operation involving the Watchdog Timer:

- Timer only mode
- Reset mode
- Interrupt mode
- Dual stage mode

At power on the Watchdog is not enabled. If not required, it is not necessary to enable it. If required, the bits of the Watchdog Timer Control Register (0x282) must be set according to the application requirements. To operate the Watchdog, the mode and time period required must first be set and then the Watchdog enabled. Once enabled, the Watchdog can only be disabled or the mode changed by powering down and then up again. To prevent a Watchdog timeout, the Watchdog must be retriggered before timing out. This is done by writing a '1' to the WTR bit. In the event a Watchdog timeout does occur, the WTE bit is set to '1'. What transpires after this depends on the mode selected.

The four operational Watchdog Timer modes can be configured by the WMD[1:0] bits, and are described as follows:

Timer only mode - In this mode the Watchdog is enabled using the required timeout period. Normally, the Watchdog is retriggered by writing a '1' to the WTR bit. In the event a timeout occurs, the WTE bit is set to '1'. This bit can then be polled by the application and handled accordingly. To continue using the Watchdog, write a '1' to the WTE bit, and then retrigger the Watchdog using WTR. The WTE bit retains its setting as long as no power down-up is done. Therefore, this bit may be used to verify the status of the Watchdog.

Reset mode - This mode is used to force a hard reset in the event of a Watchdog timeout. To be effective, the hard reset must not be masked or otherwise negated. In addition, the WTE bit is not reset by the hard reset, which makes it available if necessary to determine the status of the Watchdog prior to the reset.

Interrupt mode - This mode causes the generation of an interrupt in the event of a Watchdog timeout. The interrupt handling is a function of the application. If required, the WTE bit can be used to determine if a Watchdog timeout has occurred.

Dual stage mode - This is a complex mode where in the event of a timeout two things occur: 1) an interrupt is generated, and 2) the Watchdog is retriggered automatically. In the event a second timeout occurs immediately following the first timeout, a hard reset will be generated. If the Watchdog is retriggered normally, operation continues. The interrupt generated at the first timeout is available to the application to handle the first timeout if required. As with all of the other modes, the WTE bit is available for application use.

Table 4-9: Watchdog Timer Control Register

REGISTER NAME		WATCHDOG TIMER CONTROL REGISTER							SIZE																																																																																							
ADDRESS		0x282							8 bits																																																																																							
BIT POSITION		MSB	7	6	5	4	3	2	1	0	LSB																																																																																					
CONTENT			WTE	WMD1	WMD0	WEN/WTR	WTM3	WTM2	WTM1	WTM0																																																																																						
DEFAULT			0	0	0	0	0	0	0	0																																																																																						
ACCESS			R/W	R/W	R/W	R/W	R/W	R/W	R/W	R/W																																																																																						
BIT	NAME	DESCRIPTION/FUNCTION																																																																																														
7	WTE	Watchdog Timer Expired status bit: 0 Watchdog Timer has not expired 1 Watchdog Timer has expired Writing a '1' to this bit resets it to 0																																																																																														
6 - 5	WMD[1:0]	Watchdog mode settings: <table border="1"> <thead> <tr> <th>WMD1</th> <th>WMD0</th> <th>Mode</th> </tr> </thead> <tbody> <tr> <td>0</td> <td>0</td> <td>Timer only</td> </tr> <tr> <td>0</td> <td>1</td> <td>Reset</td> </tr> <tr> <td>1</td> <td>0</td> <td>Interrupt</td> </tr> <tr> <td>1</td> <td>1</td> <td>Dual Stage</td> </tr> </tbody> </table>										WMD1	WMD0	Mode	0	0	Timer only	0	1	Reset	1	0	Interrupt	1	1	Dual Stage																																																																						
WMD1	WMD0	Mode																																																																																														
0	0	Timer only																																																																																														
0	1	Reset																																																																																														
1	0	Interrupt																																																																																														
1	1	Dual Stage																																																																																														
4	WEN/WTR	Watchdog enable/watchdog trigger control bit: 0 Watchdog Timer has not been enabled Prior to the Watchdog being enabled, this bit is known as WEN. After the Watchdog is enabled, it is known as WTR. Once the Watchdog Timer has been enabled, this bit cannot be reset to 0. As long as the Watchdog Timer is enabled, it will indicate a '1'. 1 Watchdog Timer is enabled Writing a '1' to this bit causes the Watchdog to be retrigged to the timer value indicated by bits WTM[3:0].																																																																																														
3 - 0	WTM[3:0]	Watchdog timeout time settings: <table border="1"> <thead> <tr> <th>WTM3</th> <th>WTM2</th> <th>WTM1</th> <th>WTM0</th> <th>Value</th> </tr> </thead> <tbody> <tr> <td>0</td> <td>0</td> <td>0</td> <td>0</td> <td>125 ms</td> </tr> <tr> <td>0</td> <td>0</td> <td>0</td> <td>1</td> <td>250 ms</td> </tr> <tr> <td>0</td> <td>0</td> <td>1</td> <td>0</td> <td>500 ms</td> </tr> <tr> <td>0</td> <td>0</td> <td>1</td> <td>1</td> <td>1 s</td> </tr> <tr> <td>0</td> <td>1</td> <td>0</td> <td>0</td> <td>2 s</td> </tr> <tr> <td>0</td> <td>1</td> <td>0</td> <td>1</td> <td>4 s</td> </tr> <tr> <td>0</td> <td>1</td> <td>1</td> <td>0</td> <td>8 s</td> </tr> <tr> <td>0</td> <td>1</td> <td>1</td> <td>1</td> <td>16 s</td> </tr> <tr> <td>1</td> <td>0</td> <td>0</td> <td>0</td> <td>32 s</td> </tr> <tr> <td>1</td> <td>0</td> <td>0</td> <td>1</td> <td>64 s</td> </tr> <tr> <td>1</td> <td>0</td> <td>1</td> <td>0</td> <td>128 s</td> </tr> <tr> <td>1</td> <td>0</td> <td>1</td> <td>1</td> <td>256 s</td> </tr> <tr> <td>1</td> <td>1</td> <td>0</td> <td>0</td> <td>reserved</td> </tr> <tr> <td>1</td> <td>1</td> <td>0</td> <td>1</td> <td>reserved</td> </tr> <tr> <td>1</td> <td>1</td> <td>1</td> <td>0</td> <td>reserved</td> </tr> <tr> <td>1</td> <td>1</td> <td>1</td> <td>1</td> <td>reserved</td> </tr> </tbody> </table> The nominal timeout period is 5% longer than the above-stated values.										WTM3	WTM2	WTM1	WTM0	Value	0	0	0	0	125 ms	0	0	0	1	250 ms	0	0	1	0	500 ms	0	0	1	1	1 s	0	1	0	0	2 s	0	1	0	1	4 s	0	1	1	0	8 s	0	1	1	1	16 s	1	0	0	0	32 s	1	0	0	1	64 s	1	0	1	0	128 s	1	0	1	1	256 s	1	1	0	0	reserved	1	1	0	1	reserved	1	1	1	0	reserved	1	1	1	1	reserved
WTM3	WTM2	WTM1	WTM0	Value																																																																																												
0	0	0	0	125 ms																																																																																												
0	0	0	1	250 ms																																																																																												
0	0	1	0	500 ms																																																																																												
0	0	1	1	1 s																																																																																												
0	1	0	0	2 s																																																																																												
0	1	0	1	4 s																																																																																												
0	1	1	0	8 s																																																																																												
0	1	1	1	16 s																																																																																												
1	0	0	0	32 s																																																																																												
1	0	0	1	64 s																																																																																												
1	0	1	0	128 s																																																																																												
1	0	1	1	256 s																																																																																												
1	1	0	0	reserved																																																																																												
1	1	0	1	reserved																																																																																												
1	1	1	0	reserved																																																																																												
1	1	1	1	reserved																																																																																												



4.5.3 Geographic Addressing Register

The Geographic Addressing Register describes the CompactPCI geographic addressing signals.

Table 4-10: Geographic Addressing Register

REGISTER NAME		GEOGRAPHIC ADDRESSING REGISTER							SIZE	
ADDRESS		0x283							8 bits	
BIT POSITION	MSB	7	6	5	4	3	2	1	0	LSB
CONTENT		Res.	Res.	Res.	GA4	GA3	GA2	GA1	GA0	
DEFAULT		0	0	0	0	0	0	0	0	
ACCESS		R	R	R	R	R	R	R	R	
BIT	NAME	DESCRIPTION/FUNCTION								
7 - 5	Res.	Reserved								
4 - 0	GA[4:0]	Geographic address								

4.5.4 Hardware and Logic Revision Index Register

The Hardware and Logic Revision Index Register provides this board’s revision indices. This information can be used by the software in the event differences in the hardware and the logic require different handling by the software. It starts with the value 0x00 for the initial board prototypes and will be incremented with each change in hardware as development continues.

Table 4-11: Hardware and Logic Revision Index Register

REGISTER NAME		HARDWARE AND LOGIC REVISION INDEX REGISTER							SIZE	
ADDRESS		0x284							8 bits	
BIT POSITION	MSB	7	6	5	4	3	2	1	0	LSB
CONTENT		HWRI3	HWRI2	HWRI1	HWRI0	LRI3	LRI2	LRI1	LRI0	
DEFAULT		0	0	0	0	0	0	0	0	
ACCESS		R	R	R	R	R	R	R	R	
7 - 4	HWRI[3:0]	Hardware revision ID: 0000 Index 0000								
3 - 0	LRI[3:0]	Logic revision ID: 0000 Index 0000								



4.5.5 CPCI Reset Status Register

The CPCI Reset Status Register describes the routing of the reset signal from the CompactPCI interface to the local reset controller if the board is installed in a peripheral slot. If the board is installed in a system slot, the reset is always an output. If the reset is disabled, the CP6012 ignores the reset signal from the CompactPCI interface.

The CPCI Reset Status Register is used to determine the reset source.

Table 4-12: CPCI Reset Status Register

REGISTER NAME		CPCI RESET STATUS REGISTER							SIZE		
ADDRESS		0x285							8 bits		
BIT POSITION		MSB	7	6	5	4	3	2	1	0	LSB
CONTENT		PRST	Res.	Res.	Res.	MRST	FRST	CRST	WRST		
DEFAULT		0	0	0	0	0	0	0	0		
ACCESS		R/W	R	R	R	R/W	R/W	R/W	R/W		
BIT	NAME	DESCRIPTION/FUNCTION									
7	PRST*	0 Indicates the state after setting back the bit 1 Power-on reset (cold start)									
6 - 4	Res.	Reserved									
3	MRST*	0 System reset generated by power-on reset 1 System reset generated by BMC									
2	FRST*	0 System reset generated by power-on reset 1 System reset generated by front panel reset									
1	CRST	0 Disable the reset from the CompactPCI interface 1 Enable the reset from the CompactPCI interface									
0	WRST*	0 System reset generated by power-on reset 1 System reset generated by Watchdog									

* Read/Write Clear. Writing a '1' to this bit clears the bit.



Note ...

The CPCI Reset Status Register is set to the default values by power-on reset, not by PCI reset.



4.5.6 I/O Status Register

The I/O Status Register describes the local and CompactPCI control signals. To indicate the active Firmware Hub, the FSTA [1:0] bits are used. The CSLOT bit reflects the kind of slot in which the CP6012 is plugged in. The fail signal is an output of the power supply and indicates a power supply failure. For the description of the derate and enumeration signals, please see the Board Interrupt Configuration Register (0x289).

Table 4-13: I/O Status Register

REGISTER NAME		I/O STATUS REGISTER							SIZE	
ADDRESS		0x286							8 bits	
BIT POSITION	MSB	7	6	5	4	3	2	1	0	LSB
CONTENT	Res.	Res.	FSTA1	FSTA0	CSLOT	CENUM	CFAIL	CDER		
DEFAULT	0	0	0	0	0	0	0	0		
ACCESS	R	R	R	R	R	R	R	R		
BIT	NAME	DESCRIPTION/FUNCTION								
7 - 6	Res.	Reserved								
5 - 4	FSTA[1:0]	These bits indicate the active BIOS Firmware Hub Flash status: 00 BIOS boot from FWH0 01 BIOS boot from FWH1 10 BIOS boot from external Firmware Flash on I/O extension connector								
3	CSLOT	0 Installed in a system slot 1 Installed in a peripheral slot								
2	CENUM	0 Indicates the insertion or removal of a hot swap system board (CPCI ENUM) 1 No hot swap event								
1	CFAIL	0 Power supply failure (CPCI FAIL signal) 1 Power normal								
0	CDER	0 Power derating (CPCI DEG signal) 1 Power normal								



4.5.7 I/O Configuration Register

The I/O Configuration Register holds a series of bits defining the onboard configuration.

Table 4-14: I/O Configuration Register

REGISTER NAME		I/O CONFIGURATION REGISTER							SIZE	
ADDRESS		0x287							8 bits	
BIT POSITION	MSB	7	6	5	4	3	2	1	0	LSB
CONTENT	Res.	POST	FSEL	C66E	CXCA	P66E	PXCA	GPLE		
DEFAULT	0	0	0	0	0	0	0	0		
ACCESS	R	R/W	R/W	R	R	R	R	R/W		
BIT	NAME	DESCRIPTION/FUNCTION								
7	Res.	Reserved								
6	POST	POST LEDs configuration: 0 Enabled 1 Disabled								
5	FSEL	Firmware Hub selection: 0 FWH0 is active 1 FWH1 is active								
4	C66E	CPCI speed (CPCI_M66EN): 0 33 MHz 1 66 MHz								
3	CXCA	CPCI Bus protocol (CPCI_XCAP signal): 0 Standard PCI protocol 1 PCI-X protocol								
2	P66E	Onboard PCI speed (PCI1_XCAP signal): 0 33 MHz 1 66 MHz								
1	PXCA	Onboard PCI bus protocol (PCI1_XCAP signal): 0 Standard PCI protocol 1 PCI-X protocol								
0	GPLE	General Purpose LED enable: 0 General Purpose 1 Board-specific functionality								



4.5.8 Board ID Register

This register provides the coded ID for the board. The contents of this register is unique for each Kontron board type.

Table 4-15: Board ID Register

REGISTER NAME	BOARD ID REGISTER								SIZE	
ADDRESS	0x288								8 bits	
BIT POSITION	MSB	7	6	5	4	3	2	1	0	LSB
CONTENT		BID7	BID6	BID5	BID4	BID3	BID2	BID1	BID0	
DEFAULT		1	0	1	0	0	1	0	0	
ACCESS		R	R	R	R	R	R	R	R	
7 - 0	BID[7:0]	Board ID: 0xA4 CP6012								



4.5.9 Board Interrupt Configuration Register

The Board Interrupt Configuration Register holds a series of bits defining the interrupt routing for the Watchdog. If the Watchdog Timer fails, it can generate two independent hardware events: NMI and IRQ5 interrupt.

The enumeration signal is generated by a hot swap compatible board after insertion and prior to removal. The system uses this interrupt signal to force software to configure the new board. The derate signal indicates that the power supply is beginning to derate its power output.

Table 4-16: Board Interrupt Configuration Register

REGISTER NAME	BOARD INTERRUPT CONFIGURATION REGISTER								SIZE	
ADDRESS	0x289								8 bits	
BIT POSITION	MSB	7	6	5	4	3	2	1	0	LSB
CONTENT	Res.	CFNMI	CFIRQ	CEIRQ	CDIRQ	Res.	WIRQ1	WIRQ0		
DEFAULT	0	0	0	0	0	0	0	0		
ACCESS	R	R	R	R	R	R	R/W	R/W		
BIT	NAME	DESCRIPTION/FUNCTION								
7	Res.	Reserved								
6	CFNMI	CPCI fail signal to NMI routing: 0 Disabled 1 Enabled								
5	CFIRQ	CPCI fail signal to IRQ5 routing: 0 Disabled 1 Enabled								
4	CEIRQ	CPCI enum signal to IRQ5 routing: 0 Disabled 1 Enabled								
3	CDIRQ	CPCI derate signal to IRQ5 routing: 0 Disabled 1 Enabled								
2	Res.	Reserved								
1 - 0	WIRQ[1:0]	Watchdog interrupt routing: 00 Disabled 01 IRQ5 10 Reserved 11 NMI								



4.5.10 Hot Swap Status Register

The Hot Swap Status Register describes the hot swap handle and LED status.

Table 4-17: Hot Swap Status Register

REGISTER NAME		HOT SWAP STATUS REGISTER							SIZE	
ADDRESS		0x28A							8 bits	
BIT POSITION	MSB	7	6	5	4	3	2	1	0	LSB
CONTENT		Res.	HSH	HSLED	Res.	Res.	Res.	Res.	Res.	
DEFAULT		0	0	0	0	0	0	0	0	
ACCESS		R	R	R/W	R	R	R	R	R	
BIT	NAME	DESCRIPTION/FUNCTION								
7	Res.	Reserved								
6	HSH	0 Hot swap handle in closed position 1 Hot swap handle in open position								
5	HSLED	0 Hot swap LED off 1 Hot swap LED on								
4 - 0	Res.	Reserved								





4.5.11 Board-Specific LED Control Register

The Board-Specific LED Control Register enables the user to switch the Front-I and Front-II LEDs on the front panel on and off.

Table 4-18: Board-Specific LED Control Register

REGISTER NAME		BOARD-SPECIFIC LED CONTROL REGISTER						SIZE			
ADDRESS		0x28D						8 bits			
BIT POSITION		MSB	7	6	5	4	3	2	1	0	LSB
CONTENT		LED7	LED6	LED5	LED4	LED3	LED2	LED1	LED0		
DEFAULT		0	0	0	0	0	0	0	0		
ACCESS		R/W	R/W	R/W	R/W	R/W	R/W	R/W	R/W		
BIT	NAME	DESCRIPTION / FUNCTION									
7	LED7	LED7 control settings: 0 LED off 1 LED on									
6	LED6	LED6 control settings: 0 LED off 1 LED on									
5	LED5	LED5 control settings: 0 LED off 1 LED on									
4	LED4	LED4 control settings: 0 LED off 1 LED on									
3	LED3	LED3 control settings: 0 LED off 1 LED on									
2	LED2	LED2 control settings: 0 LED off 1 LED on									
1	LED1	LED1 control settings: 0 LED off 1 LED on									
0	LED0	LED0 control settings: 0 LED off 1 LED on									



4.5.12 Delay Timer Control/Status Register

The delay timer enables the user to realize short, reliable delay times. It runs by default and does not start again on its own. It can be restarted at anytime by writing anything other than a '0' to the Delay Timer Control/Status Register. The hardware delay timer provides a set of outputs for defined elapsed time periods. The timer outputs reflected in the Delay Timer Control/Status Register are set consecutively and remain set until the next restart is triggered again.

Table 4-19: Delay Timer Control/Status Register

REGISTER NAME		DELAY TIMER CONTROL/STATUS REGISTER							SIZE																												
ADDRESS		0x28F							8 bits																												
BIT POSITION	MSB	7	6	5	4	3	2	1	0	LSB																											
CONTENT		DTC7	DTC6	DTC5	DTC4	DTC3	DTC2	DTC1	DTC0																												
DEFAULT		0	0	0	0	0	0	0	0																												
ACCESS		R/W	R/W	R/W	R/W	R/W	R/W	R/W	R/W																												
BIT	NAME	DESCRIPTION/FUNCTION																																			
7 - 0	DTC[7:0]	The hardware delay timer is operated via one simple 8-bit control/status register. During normal operation, each of the 8 bits reflects a timer output which means defined elapsed time period after the last restart according to the following bit mapping: <table border="1" style="margin-left: 20px;"> <thead> <tr> <th>DTC[7:0]</th> <th>Value</th> <th>Accuracy</th> </tr> </thead> <tbody> <tr> <td>Bit 7:</td> <td>1 ms</td> <td>< + 0.04%</td> </tr> <tr> <td>Bit 6:</td> <td>500 μs</td> <td>< + 0.08%</td> </tr> <tr> <td>Bit 5:</td> <td>250 μs</td> <td>< + 0.16%</td> </tr> <tr> <td>Bit 4:</td> <td>100 μs</td> <td>< + 0.4%</td> </tr> <tr> <td>Bit 3:</td> <td>50 μs</td> <td>< + 0.8%</td> </tr> <tr> <td>Bit 2:</td> <td>10 μs</td> <td>< + 4%</td> </tr> <tr> <td>Bit 1:</td> <td>5 μs</td> <td>< + 8%</td> </tr> <tr> <td>Bit 0:</td> <td>1 μs</td> <td>< + 40%</td> </tr> </tbody> </table>									DTC[7:0]	Value	Accuracy	Bit 7:	1 ms	< + 0.04%	Bit 6:	500 μs	< + 0.08%	Bit 5:	250 μs	< + 0.16%	Bit 4:	100 μs	< + 0.4%	Bit 3:	50 μs	< + 0.8%	Bit 2:	10 μs	< + 4%	Bit 1:	5 μs	< + 8%	Bit 0:	1 μs	< + 40%
DTC[7:0]	Value	Accuracy																																			
Bit 7:	1 ms	< + 0.04%																																			
Bit 6:	500 μs	< + 0.08%																																			
Bit 5:	250 μs	< + 0.16%																																			
Bit 4:	100 μs	< + 0.4%																																			
Bit 3:	50 μs	< + 0.8%																																			
Bit 2:	10 μs	< + 4%																																			
Bit 1:	5 μs	< + 8%																																			
Bit 0:	1 μs	< + 40%																																			

Since the timer width and thus the availability of outputs varies over different implementations, it is necessary to be able to determine the timer capability. Therefore, writing a '0' to the Delay Timer Control/Status Register followed by reading indicates the timer capability (not the timer outputs). For example, writing 0x00 and then reading 0xFF results in a 8-bit wide timer register. This status register mode can be switched to normal timer operation by writing anything other than a '0' to this register.





4.6 BMC-Specific Registers

The following registers are special registers which the CP6012 uses to monitor and configure the Board Management Controller.

4.6.1 BMC Configuration Register

The BMC Configuration Register holds a series of bits defining the serial port routing and BMC configuration and Super I/O. The COM2 port can be used for firmware update or debugging.

Table 4-20: BMC Configuration Register

REGISTER NAME		BMC CONFIGURATION REGISTER						SIZE			
ADDRESS		0x19C						8 bits			
BIT POSITION		MSB	7	6	5	4	3	2	1	0	LSB
CONTENT		BMC_PCF	Res.	Res.	Res.	BMC_EXT	BMC_COM	BMC_RST	BMC_PRG		
DEFAULT		0	0	0	0	0	0	0	0		
ACCESS		R/W	R	R	R	R	R/W	R/W	R/W		
BIT	NAME	DESCRIPTION / FUNCTION									
7	BMC_PCF	BMC program mode configuration: 0 BMC programming mode update disabled 1 BMC programming mode update internal flash from external flash									
6 - 4	Res.	Reserved									
3	BMC_EXT	BMC COM port configuration for debugging: 0 BMC COM port is connected to COM USB converter 1 BMC COM port is isolated									
2	BMC_COM	BMC COM port configuration for Firmware update: 0 Super I/O COM2 port is connected to BMC 1 Super I/O COM2 port is connected to COM2 connector. This bit is ignored if the BMC_COM signal is 0.									
1	BMC_RST	BMC reset function: 0 BMC controller is running 1 Reset BMC controller									
0	BMC_PRG	BMC program mode: 0 Set normal operating mode 1 Set BMC controller in program mode									

To allow updating the Firmware of the BMC controller, the software must set BMC_RST and BMC_PRG, and clear BMC_RST after 10 msec. Now, the microcontroller boots from COM2. After programming is completed, BMC_RST must be set and BMC_PRG must be cleared. After 10 msec, BMC_RST must be cleared again. The microcontroller now boots from its own Flash. To allow updating the Firmware of the BMC controller during regular Firmware operation, the software may use the appropriate FirmWare Upgrade Manager (FWUM) commands. FWUM API is the Kontron extension to the IPMI commands set and is available via both the KCS and IPMB interfaces.



The following table indicates the COM port routing for the Firmware update.

Table 4-21: COM Port Routing for the Firmware Update

BMC_PRG	BMC_COM	BMC_EXT	BMC COM PORT	Super I/O COM2 PORT
0	0	1	Disabled	COM2 connector
0	1	1	Super I/O COM2	BMC
0	--	0	COM2 connector	Disabled
1	--	--	Super I/O COM2	BMC



Note ...

Setting BMC_PRG inhibits the functionality of BMC_COM and BMC_EXT.

4.6.1.1 BMC Interrupt Configuration Register

The BMC Interrupt Configuration Register holds a series of bits defining the interrupt routing for the BMC controller.

Table 4-22: BMC Interrupt Configuration Register

REGISTER NAME	BMC INTERRUPT CONFIGURATION REGISTER							SIZE		
ADDRESS	0x19F							8 bits		
BIT POSITION	MSB	7	6	5	4	3	2	1	0	LSB
CONTENT	Res.	Res.	Res.	Res.	Res.	BMC_ISA7	Res.	BMC_SMI		
DEFAULT	0	0	0	0	0	0	0	0		
ACCESS	R	R	R	R	R	R/W	R	R/W		
BIT	NAME	DESCRIPTION / FUNCTION								
7 - 3	Res.	Reserved								
2	BMC_ISA7	BMC ISA style IRQ routing: 0 Disable IRQ7 1 Enable IRQ7								
1	Res.	Reserved								
0	BMC_SMI	BMC SMI routing: 0 Disable SMI 1 Enable SMI								





4.6.2 IPMI Keyboard Control Style Interface

The host processor communicates with the BMC using two Keyboard Control Style interfaces, which are defined in the IPMI specification. One interface is for the System Management Software (SMS) used within an operating system, and one for the System Management Mode (SMM) used only by the BIOS.

The KCS interface for the system management software is on the I/O location 0xCA2 and 0xCA3, and configured as regular ISA interrupt.

The KCS interface for the system management mode is on the I/O location 0xCA4 and 0xCA5, and configured as SMI interrupt.



This page has been intentionally left blank.





Chapter

5

Power Considerations



This page has been intentionally left blank.





5. Power Considerations

5.1 System Power

The considerations presented in the ensuing chapters must be taken into account by system integrators when specifying the CP6012 system environment.

5.1.1 CP6012 Baseboard

The CP6012 baseboard itself has been designed for optimal power input and distribution. Still it is necessary to observe certain criteria essential for application stability and reliability.

The table below indicates the absolute maximum input voltage ratings that must not be exceeded. Power supplies to be used with the CP6012 should be carefully tested to ensure compliance with these ratings.

Table 5-1: Maximum Input Power Voltage Limits

SUPPLY VOLTAGE	MAXIMUM PERMITTED VOLTAGE
+3.3 V	+3.6 V
+5 V	+5.5 V
+12 V	+14.0 V
-12 V	-14.0 V



Warning!

The maximum permitted voltage indicated in the table above must not be exceeded. Failure to comply with the above may result in damage to your board.

The following table specifies the ranges for the different input power voltages within which the board is functional. The CP6012 is not guaranteed to function if the board is not operated within the prescribed limits.

Table 5-2: DC Operational Input Voltage Ranges

INPUT SUPPLY VOLTAGE	ABSOLUTE RANGE	RECOMMENDED RANGE
+3.3 V	3.2 V min. to 3.47 V max.	3.3 V min. to 3.47 V max.
+5 V	4.85 V min. to 5.25 V max.	5.0 V min. to 5.25 V max.
+12 V	11.4 V min. to 12.6 V max.	12 V min. to 12.6 V max.
-12 V	-11.4 V min. to -12.6 V max.	Only for PMC



5.1.2 Backplane

Backplanes to be used with the CP6012 must be adequately specified. The backplane must provide optimal power distribution for the +3.3 V, +5 V and +12 V power inputs. It is recommended to use only backplanes which have at least two power planes for the 3.3 V and +5 V voltages.

Input power connections to the backplane itself should be carefully specified to ensure a minimum of power loss and to guarantee operational stability. Long input lines, under dimensioned cabling or bridges, high resistance connections, etc. must be avoided. It is recommended to use POSITRONIC or M-type connector backplanes and power supplies where possible.

5.1.3 Power Supply Units

Power supplies for the CP6012 must be specified with enough reserve for the remaining system consumption. In order to guarantee stability of the system, it is recommended to provide more power than the system requires. An industrial power supply unit should be able to provide at least twice as much power as the entire system requires. An ATX power supply unit should be able to provide at least three times as much power as the entire system requires.

As the design of the CP6012 has been optimized for minimal power consumption, the power supply unit must be stable even without a minimum load.

Where possible, power supplies which support voltage sensing should be used. Depending on the system configuration this may require an appropriate backplane. The power supply should be sufficient to allow for die resistance variations.



Note ...

Non-industrial ATX PSUs require a greater minimum load than a single CP6012 is capable of creating. When a PSU of this type is used, it will not power up correctly and the CP6012 may hangup. The solution is to use an industrial PSU or to add more load to the system.

The start-up behavior of CPCI and PCI (ATX) power supplies is critical for all new CPU boards. These boards require a defined power sequence and start-up behavior of the power supply. For information on the required behavior refer to the power supply specifications on the formfactors.org web site and to the CompactPCI (PICMG) specification on the picmgeu.org web site.

5.1.3.1 Start-Up Requirement

Power supplies must comply with the following guidelines, in order to be used with the CP6012.

- Beginning at 10% of the nominal output voltage, the voltage must rise within > 0.1 ms to < 20 ms to the specified regulation range of the voltage. Typically: > 5 ms to < 15 ms.
- There must be a smooth and continuous ramp of each DC output voltage from 10% to 90% of the regulation band.
- The slope of the turn-on waveform shall be a positive, almost linear voltage increase and have a value from 0 V to nominal Vout.



Warning!

For BIOS initialization of the memory interface, the 3.3 V input power supply must be able to provide a minimum peak current of 10 A to the CP6012. This applies for each CP6012 in a given system.

Failure to comply with the above warning may result in improper operation of the CP6012.



5.1.3.2 Power-Up Sequence

The +5 VDC output level must always be equal to or higher than the +3.3 VDC output during power-up and normal operation.

Both voltages must reach their minimum in-regulation level not later than 20 ms after the output power ramp start.

5.1.3.3 Tolerance

The tolerance of the voltage lines is described in the CPCI specification (PICMG 2.0 R3.0). The recommended measurement point for the voltage is the CPCI connector on the CPU board.

The following table provides information regarding the required characteristics for each board input voltage.

Table 5-3: Input Voltage Characteristics

VOLTAGE	NOMINAL VALUE	TOLERANCE	MAX. RIPPLE (p-p)	REMARKS
5 V	+5.0 VDC	+5%/-3%	50 mV	Main voltage
3.3 V	+3.3 VDC	+5%/-3%	50 mV	--
+12 V	+12 VDC	+5%/-5%	240 mV	Required
-12 V	-12 VDC	+5%/-5%	240 mV	Not required
VI/O (PCI) voltage	+3.3 VDC or +5 VDC	+5%/-3%	50 mV	Standard Version +5.0 V
GND	Ground, not directly connected to potential earth (PE)			

The output voltage overshoot generated during the application (load changes) or during the removal of the input voltage must be less than 5% of the nominal value. No voltage of reverse polarity may be present on any output during turn-on or turn-off.



5.1.3.4 Regulation

The power supply shall be unconditionally stable under line, load, unload and transient load conditions including capacitive loads. The operation of the power supply must be consistent even without the minimum load on all output lines.



Warning!

All of the input voltages must be functionally coupled to each other so that if one input voltage fails, all other input voltages must be regulated proportionately to the failed voltage. For example, if the +5V begins to decrease, all other input voltages must decrease accordingly. This is required in order to preclude cross currents within the CP6012.

Failure to comply with above may result in damage to the board or improper system operation.



Note ...

If the main power input is switched off, the supply voltages will not go to 0V instantly. It will take a couple of seconds until capacitors are discharged. If the voltage rises again before it has gone below a certain level, the circuits may enter a latch-up state where even a hard RESET will not help any more. The system must be switched off for at least 30 seconds before it may be switched on again. If short interruptions of the power supply still occur, it is recommended to use uninterrupted power supply units or power-on delay devices.

5.1.3.5 Rise Time Diagram

The following figure illustrates an example of the recommended start-up ramp of a CPCI power supply for all Kontron boards delivered up to now.

Figure 6-1: Start-Up Ramp of the CP3-SVE180 AC Power Supply

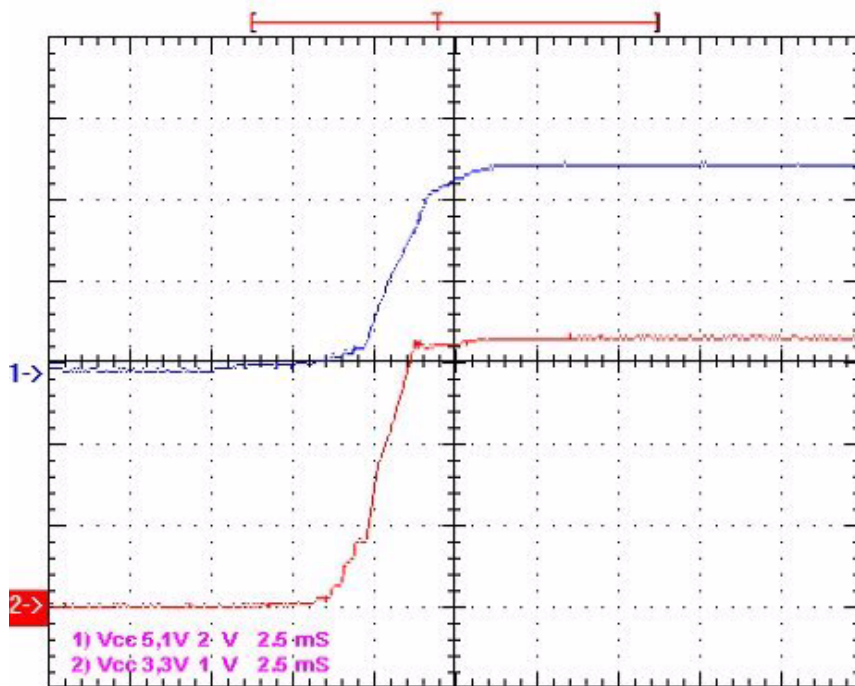



5.2 Power Consumption

The goal of this description is to provide a method to calculate the power consumption for the CP6012 baseboard and for additional configurations. The processor dissipates the majority of the thermal power.

The power consumption tables below list the voltage and the power specifications for the CP6012 board and its accessories. The values were measured using an 8-slot passive CompactPCI backplane with two power supplies, one for the CPU, and the other for the hard disk. The operating systems used were DOS, Linux and Windows® XP. All measurements were conducted at a temperature of 25°C. The measured values varied, because the power consumption was dependent on the processor activity.



Note ...

The power consumption values indicated in the tables below can vary depending on the ambient temperature or the system performance. This can result in deviations of the power consumption values of up to 10%.

The power consumption was measured using the following processors:

- Intel® Core™ Duo, L2400 (LV), 1.66 GHz, 667 MHz FSB, 2 MB L2 cache
- Intel® Core™ Duo, T2500 (SV), 2.0 GHz, 667 MHz FSB, 2 MB L2 cache
- Intel® Core™ 2 Duo, L7400 (LV), 1.5 GHz, 667 MHz FSB, 4 MB L2 cache
- Intel® Core™ 2 Duo, T7400 (SV), 2.16 GHz, 667 MHz FSB, 4 MB L2 cache

with the following operating systems:

- DOS
With this operating system only one processor core was active. This operating system has no power management support and provides a very simple method to verify the measured power consumption values.
- Linux/Windows® XP, IDLE Mode
With these operating systems both processor cores were in IDLE state.

and under the following testing conditions:

- CP6012's Thermal Design Power (TDP) at 75%
These values represent the "typical" maximum power dissipation reached under OS-controlled applications.
- CP6012's Thermal Design Power (TDP) at 100%
These values represent the maximum power dissipation achieved through the use of specific tools to heat up the processor cores. 100% TDP is unlikely to be reached in real applications.

The following tables indicate the power consumption of the CP6012 with 2 GB DDR2 SDRAM (one 1 GB SODIMM memory module mounted on each socket). For measurements made with the Linux and Windows® XP operating systems, the VGA resolution was 1024 x 768 pixels.



Table 5-4: Power Consumption: CP6012 with DOS

POWER	CORE™ DUO 1.66 GHz (LV) 2 MB	CORE™ DUO 2.0 GHz (SV) 2 MB	CORE™ 2 DUO 1.5 GHz (LV) 4 MB	CORE™ 2 DUO 2.16 GHz (SV) 4 MB
12 V	50 mW	50 mW	50 mW	50 mW
5 V	8 W	15 W	9 W	17 W
3.3 V	18 W	19 W	20 W	20 W
Total	26 W	34 W	29 W	37 W

Table 5-5: Power Consumption: CP6012 with Linux/Win. XP in IDLE Mode

POWER	CORE™ DUO 1.66 GHz (LV) 2 MB	CORE™ DUO 2.0 GHz (SV) 2 MB	CORE™ 2 DUO 1.5 GHz (LV) 4 MB	CORE™ 2 DUO 2.16 GHz (SV) 4 MB
12 V	50 mW	50 mW	50 mW	50 mW
5 V	4 W	8 W	5 W	9 W
3.3 V	18 W	19 W	18 W	20 W
Total	22 W	27 W	23 W	29 W

Table 5-6: Power Consumption: CP6012's TDP at 75%

POWER	CORE™ DUO 1.66 GHz (LV) 2 MB	CORE™ DUO 2.0 GHz (SV) 2 MB	CORE™ 2 DUO 1.5 GHz (LV) 4 MB	CORE™ 2 DUO 2.16 GHz (SV) 4 MB
12 V	50 mW	50 mW	50 mW	50 mW
5 V	13 W	29 W	16 W	32 W
3.3 V	18 W	19 W	19 W	20 W
Total	31 W	48 W	35 W	52 W

Table 5-7: Power Consumption: CP6012's TDP at 100%

POWER	CORE™ DUO 1.66 GHz (LV) 2 MB	CORE™ DUO 2.0 GHz (SV) 2 MB	CORE™ 2 DUO 1.5 GHz (LV) 4 MB	CORE™ 2 DUO 2.16 GHz (SV) 4 MB
12 V	50 mW	50 mW	50 mW	50 mW
5 V	15 W	32 W	19 W	35 W
3.3 V	19 W	20 W	20 W	21 W
Total	34 W	52 W	39 W	56 W





5.2.1 Power Consumption of the CP6012 Accessories

The following table indicates the power consumption of the CP6012 accessories.

Table 5-8: Power Consumption of CP6012 Accessories

MODULE	POWER 5 V	POWER 3.3 V AVERAGE
Keyboard	100 mW	—
DDR2 SDRAM SODIMM PC2 3200 (DDR2 400) 1 GB	—	2 W - 6 W
DDR2 SDRAM SODIMM PC2 3200 (DDR2 400) 2 GB	—	6 W - 8 W
CompactFlash	—	100 mW - 300 mW

5.2.2 Power Consumption of the Dual Gigabit Ethernet Controller

The following table indicates the Intel® 82571EB Gigabit Dual Ethernet controller power supply characteristics.

Table 5-9: Intel® 82571EB Dual Gigabit Ethernet Controller Power Supply

ETHERNET PORTS	SPEED	POWER
BOTH ETHERNET PORTS UNPLUGGED	--	0.69 W
BOTH ETHERNET PORTS PLUGGED (2 X FRONT AND 2 X REAR)	100 Mbs	1.31 W
BOTH ETHERNET PORTS PLUGGED (2 X FRONT AND 2 X REAR)	1000 Mbs	3.43 W
ONE ETHERNET PORT PLUGGED (1 X FRONT AND 1 X REAR)	1000 Mbs	2.1 W



5.3 Start-Up Currents of the CP6012

The following table indicates the basic start-up currents of the CP6012 during the first 2-3 seconds after power has been applied (power-on or hot-swap insertion). In addition to these values, each time when the BIOS initializes the memory interface (power-on, hot-swap, reset), there can be a peak load of 10 A on the 3.3 V input power supply.

Table 5-10: Start-Up Currents of the CP6012

POWER		CORE™ DUO 1.66 GHz (LV) 1 GB sold. DDR2	CORE™ DUO 2.0 GHz (SV) 1 GB sold. DDR2	CORE™ 2 DUO 1.5 GHz (LV) 1 GB sold. DDR2	CORE™ 2 DUO 2.16 GHz (SV) 1 GB sold. DDR2
5 V	peak	6.9 A	6.9 A	6.9 A	6.9 A
	average	2.0 A	2.0 A	2.0 A	2.0 A
3.3 V	peak	5.1 A	5.1 A	5.1 A	5.1 A
	average	3.2 A	3.2 A	3.2 A	3.2 A

For further information on the start-up current, contact Kontron's Technical Support.



Warning!

For BIOS initialization of the memory interface, the 3.3 V input power supply must be able to provide a minimum peak current of 10 A to the CP6012. This applies for each CP6012 in a given system.

Failure to comply with the above warning may result in improper operation of the CP6012.

5.4 Power Available for PMC Devices

The following table indicates the power made available by the CP6012 to PMC devices.

Table 5-11: Maximum Output Power Limits

VOLTAGE	CONTINUOUS CURRENT	PEAK CURRENT
+3.3 V	2.27 A	4.0 A
+5 V	1.5 A	3.0 A*
+12 V	0.6 A	0.8 A
-12 V	0.4 A	0.4 A

* The maximum current available on the PMC module varies depending on the CPU load.



Note ...

A maximum power of 7.5 W is available on the pins of the PMC connectors J26 and J28, which provide a voltage of 3.3 V or 5 V. This is in accordance with the draft standard P1386/Draft 2.4a. The maximum power of 7.5 W can be arbitrarily divided on the 3.3 V and 5 V voltage lines.

The +12 V and -12 V voltage lines are only required for operation of PMC modules. Their availability depends on the power supply.



Chapter

6

Thermal Considerations



This page has been intentionally left blank.





6. Thermal Considerations

The following chapters provide system integrators with the necessary information to satisfy thermal requirements when implementing CP6012 applications.

6.1 Board Internal Thermal Regulation

The thermal management architecture implemented on the CP6012 can be described as being two separate but related functions. The goal of these two functions is to protect the processor through the reduction of the processor power consumption. Enabling the thermal control circuit allows the processor to maintain a safe operating temperature without the need for special software drivers or interrupt handling routines.

The two thermal protection functions provided by the processor are:

1. Intel® Core™ Duo and Intel® Core™ 2 Duo Thermal Supervision:

This function controls the processor temperature by SpeedStep® or clock modulation via the internal Digital Thermal Sensor (DTS).

2. Thermtrip:

In the event of a catastrophic cooling failure resulting in extreme overheating, the processor will automatically shut down when the die temperature has reached approximately 125 °C. This event is known as “Thermtrip”.

6.1.1 CPU Internal Thermal Supervision

This function can be enabled and disabled in the BIOS, whereby the default value is: enabled. When the internal thermal control circuit has been enabled and a high temperature situation occurs, the internal clocks are controlled by SpeedStep®. If this is not sufficient, the clocks are additionally modulated by alternately turning them off and on with a 50% duty cycle. This results in the reduction of the processor power consumption and the processor performance depending on the active SpeedStep® and the duty cycle. Cycle times are processor speed dependent and will decrease linearly as processor core frequencies increase. The thermal control circuit is automatically deactivated when the temperature goes below the internal thermal supervision point. The internal temperature sensors are located near to the hottest area of the processor dies. Each processor is individually calibrated during manufacturing to eliminate any potential manufacturing variations.



Note ...

The duty cycle and the internal thermal supervision point is factory configured by Intel and cannot be modified. For all Intel® Core™ Duo and Intel® Core™ 2 Duo processors, the internal thermal supervision point is 100 °C.



6.1.2 CPU Emergency Thermal Supervision (Thermtrip)

This function cannot be enabled or disabled in the BIOS. It is always enabled to ensure that the processor is protected in any event.

Assertion of Thermtrip indicates that the processor junction temperature has reached a level beyond which permanent silicon damage may occur. Measurement of the temperature is accomplished through an internal thermal sensor which is configured to trip at approximately 125°C. Upon assertion of Thermtrip, the processor will shut off its internal clocks (thus halting program execution) in an attempt to reduce the processor junction temperature. Once activated, Thermtrip remains latched until the CP6012 undergoes a cold restart (all power off and then on again).



Note ...

Upon assertion of Thermtrip, the front panel overtemperature LED flashes at regular intervals.

6.2 Thermal Management Recommendations

If the CP6012 is operated in a properly configured CompactPCI environment with enough air-flow, there is no need to enable the Thermal Management function. However, sometimes the system environment is not optimized for an Intel® Core™ Duo or an Intel® Core™ 2 Duo processor board and this requires thermal protection to guarantee a stable system. The Thermal Management feature allows system designers to design lower cost thermal solutions without compromising system integrity or reliability.

If the system is not optimized for the CP6012, the internal Thermal Monitor should be enabled. The monitor protects the processor and the system against excessive temperatures. In this configuration the clock will be switched on and off. For example, at a 50% duty cycle, the average power dissipation can drop by up to 50%. In this case, the processor performance also drops by about 50% since program execution halts when the clock is removed.



Warning!

For Benchmarks and performance tests all Thermal Management functions should be disabled; if enabled, the results will be erroneous due to the thermal power reduction.



6.3 External Thermal Regulation

The thermal management concept of the CP6012 also encompasses external thermal regulation. For the Intel® Core™ Duo and the Intel® Core™ 2 Duo processors, a specifically designed heat sink is employed to ensure the best possible basis for operational stability and long term reliability. Coupled together with system chassis which provide variable configurations for forced airflow, thermal energy dissipation is guaranteed.

6.3.1 Heat Sink

Even though the CP6012 is fitted with an optimally designed passive heat sink, it still requires forced airflow which must be provided by the CompactPCI system.

The following heat sink types are used on the CP6012:

- Narrow heat sink
- Wide heat sink (obsolete)

6.3.2 Forced Airflow

When developing applications using the CP6012, the system integrator must be aware of the overall system thermal requirements. System chassis must be provided which satisfy these requirements. As an aid to the system integrator, characteristics graphs are provided for the CP6012.

The values have been measured using typical applications running under Windows® XP. In worst case situations, the values vary and the temperature range must be reduced. In all situations, the maximum case temperature of the Intel® Core™ Duo and the Intel® Core™ 2 Duo processors must be kept below the maximum allowable temperature. This temperature value can be measured with the temperature sensor integrated in the CPU. To ensure functionality at the maximum temperature, the BIOS supports a temperature control feature. In instances of overtemperature, the hardware monitor will reduce the power consumption.

The maximum case temperatures for both processor types is as follows:

- Intel® Core™ Duo: all versions: 100 °C
- Intel® Core™ 2 Duo: all versions: 100 °C

Although the basic thermal management of the CP6012 involves primarily the CPU, there are other board components which may have to be considered when an application is designed. This can be necessary for situations when the CP6012 is operated at higher ambient air temperatures whereby the CPU can protect itself, but the other board components have no thermal protection means except the system forced airflow. Thermal monitoring of the CP6012 must be an integrated function of the application design.



6.3.3 Thermal Characteristic Graphs

The thermal characteristic graphs shown on the following pages illustrate the maximum ambient air temperature as a function of the volumetric airflow rate for the power consumption indicated. The diagrams are intended to serve as guidance for reconciling board and system with the required computing power considering the thermal aspect. One diagram per CPU version is provided. There are up to two curves representing upper level working points based on different levels of average CPU utilization. When operating below the corresponding curve, the CPU runs steadily without any intervention of thermal supervision. When operated above the corresponding curve, various thermal protection mechanisms may take effect resulting in temporarily reduced CPU performance or finally in an emergency stop in order to protect the CPU from thermal destruction. In real applications this means that the board can be operated temporarily at a higher ambient temperature or at a reduced flow rate and still provide some margin for temporarily requested peak performance before thermal protection will be activated.

TDP curves

- 100% TDP curve
This load complies with the maximum thermal design power (TDP) indicated in Chapter 5.2 Power Consumption, Table 5-7. 100% TDP can be achieved through the use of specific tools to heat up the CPU but 100% TDP is unlikely to be reached in real applications.
- 75% TDP curve
This load represents a "typical" maximum power consumption reached under OS controlled applications. Typically, this load corresponds with 75% of the TDP (see Chapter 5.2 Power Consumption, Table 5-6).

How to read the diagram

Select a specific CPU and choose a specific working point indicated in TDP percentage. For a given flow rate there is a maximum airflow input temperature (= ambient temperature) provided. Below this operating point, thermal supervision will not be activated. Above this operating point, thermal supervision will become active protecting the CPU from thermal destruction. The minimum airflow rate provided must not be less than the value specified in the diagram.

Volumetric flow rate

The volumetric flow rate refers to an airflow through a fixed cross-sectional area (i.e. slot width x depth). The volumetric flow rate is specified in m³/h (cubic-meter-per-hour) or cfm (cubic-feet-per-minute) respectively.

Conversion: 1 cfm = 1.7 m³/h; 1 m³/h = 0.59 cfm

Airflow

At a given cross-sectional area and a required flow rate, an average, homogeneous airflow speed can be calculated using the following formula:

Airflow = Volumetric flow rate / area.

The airflow is specified in m/s (meter-per-second) or in fps (feet-per-second) respectively.

Conversion: 1 fps = 0.3048 m/s; 1 m/s = 3.28 fps

The following figures illustrate the operational limits of the CP6012 taking into consideration power consumption vs. ambient air temperature vs. airflow rate. The measurements were made based on a 4HP slot and with both processor cores enabled.



Figure 6-1: Operating Limits: Core™ Duo 1.66 GHz, Narrow Heat Sink

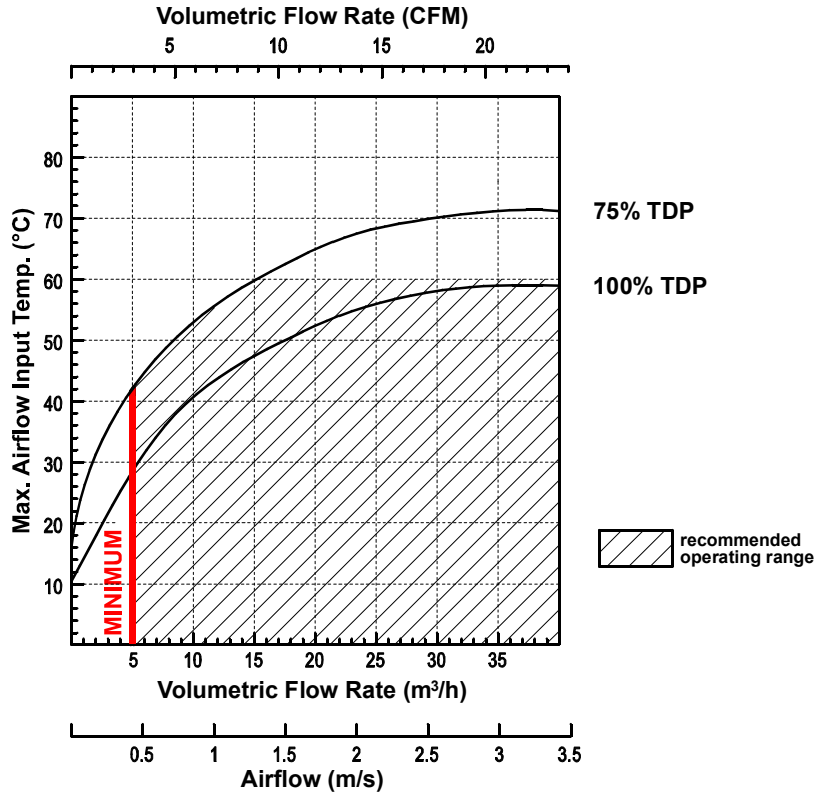

Figure 6-2: Operating Limits: Core™ Duo 2.0 GHz, Wide Heat Sink

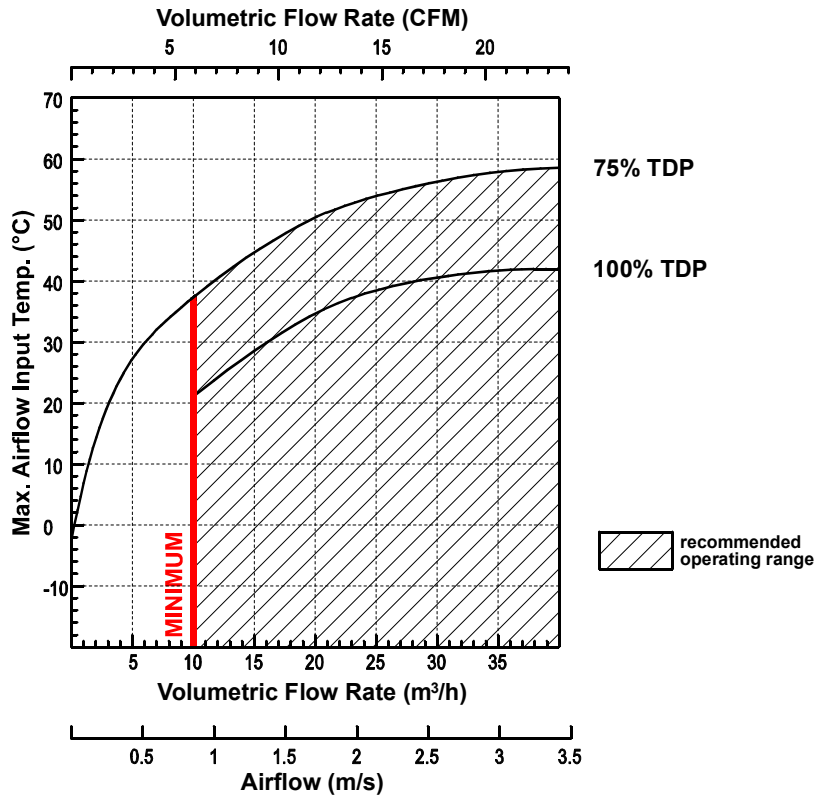



Figure 6-3: Operating Limits: Core™ 2 Duo 1.5 GHz, Narrow Heat Sink

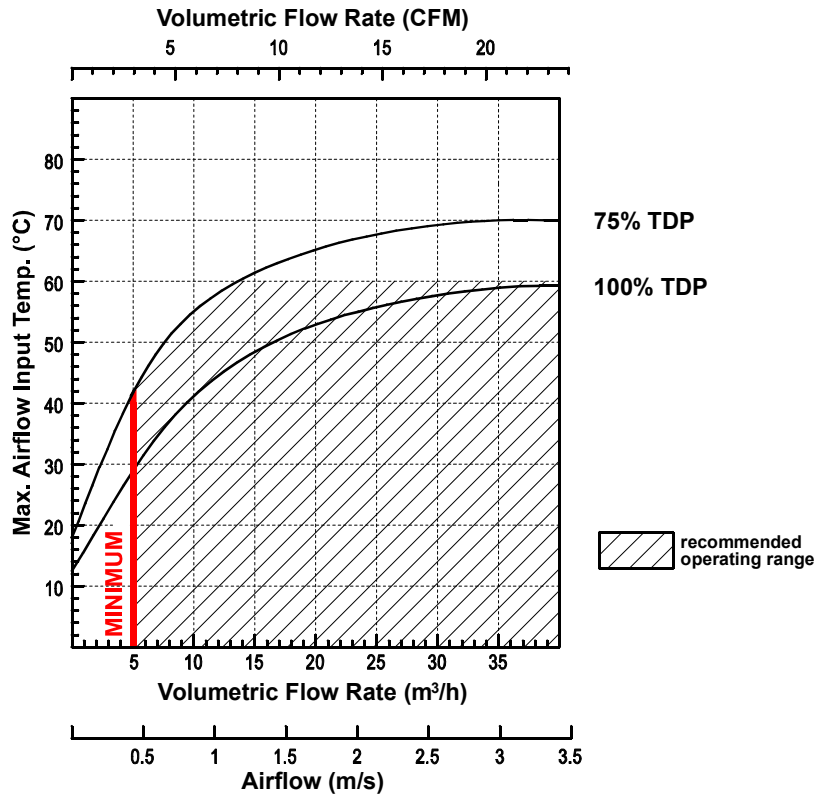

Figure 6-4: Operating Limits: Core™ 2 Duo 2.16 GHz, Wide Heat Sink

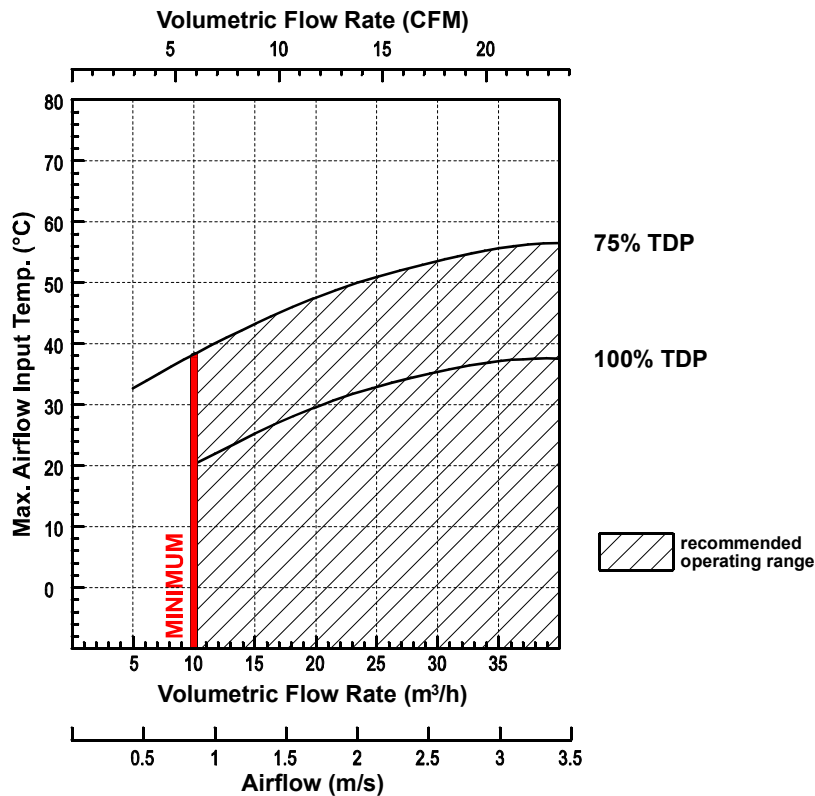



Figure 6-5: Operating Limits: Core™2 Duo 2.16 GHz, Narrow Heat Sink

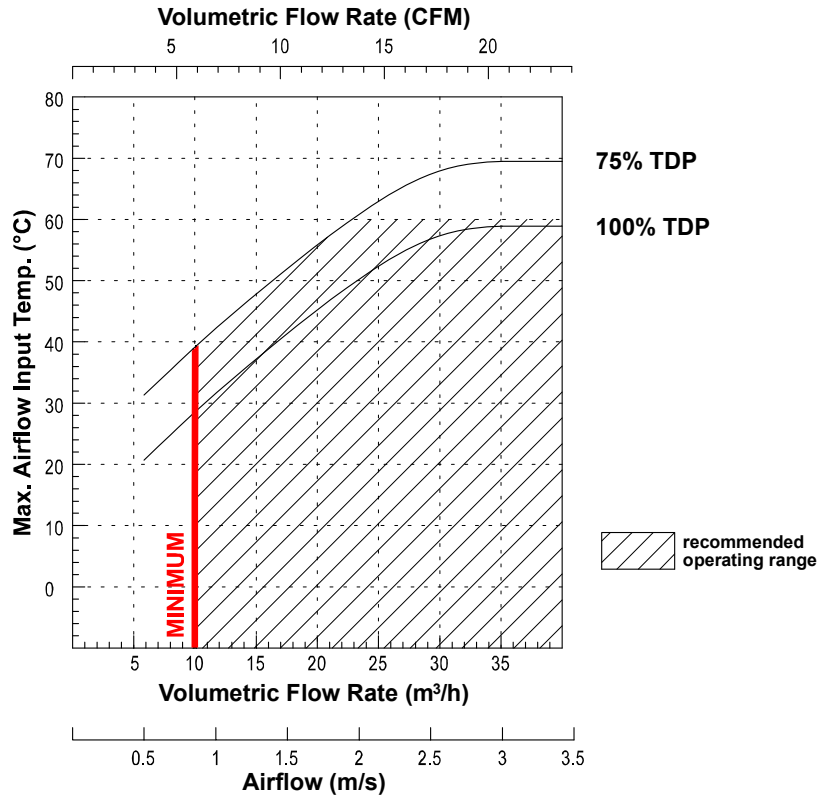
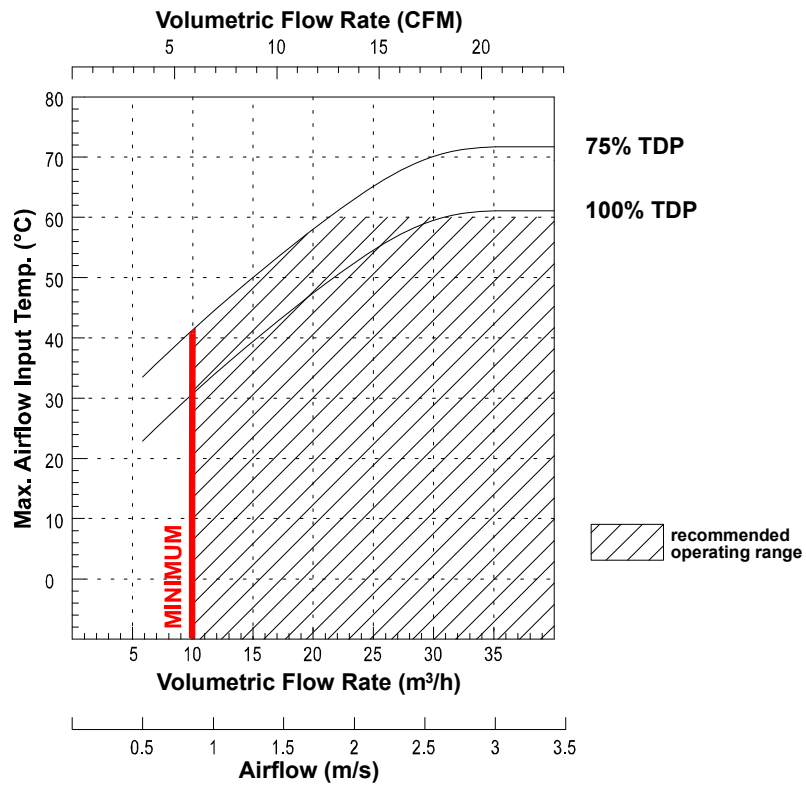

Figure 6-6: Operating Limits: Core™ Duo 2.0 GHz, Narrow Heat Sink





An airflow of 1.0 m/s is a typical value for a standard *Kontron* ASM rack (6U CompactPCI rack with a 1U cooling fan tray). Newer ASMs from *Kontron* will have an airspeed of 2.0 m/s or more. For other racks or housings the available airflow will differ. The maximum ambient operating temperature must be recalculated and/or measured for such environments. For the calculation of the maximum ambient operating temperature, the processor junction temperature must never exceed the specified limit for the involved processor type.

6.3.4 Peripherals

When determining the thermal requirements for a given application, peripherals to be used with the CP6012 must also be considered. Devices such as hard disks, PMC modules, etc. which are directly attached to the CP6012 must also be capable of being operated at the temperatures foreseen for the application. It may very well be necessary to revise system requirements to comply with operational environment conditions. In most cases, this will lead to a reduction in the maximum allowable ambient operating temperature or even require active cooling of the operating environment.



Warning!

As Kontron assumes no responsibility for any damage to the CP6012 or other equipment resulting from overheating of the CPU, it is highly recommended that system integrators as well as end users confirm that the operational environment of the CP6012 complies with the thermal considerations set forth in this document.



Appendix



CTM80-3 RIO Module



This page has been intentionally left blank.

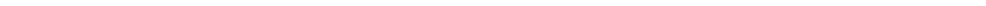



A. CTM80-3 RIO Module

A.1 Introduction

The CTM80-3 rear I/O module is available for use with the CP6012 6U CompactPCI board from Kontron. This rear I/O module provides comprehensive rear I/O functionality. There are three different CTM80-3 versions available, with SCSI configuration, with PATA configuration, and with SATA configuration. The CTM80-3 rear I/O module has been designed for use both in a PICMG 2.16 and a non-PICMG 2.16 environment.

Everything that can be routed through the front panel may also be routed through the rear I/O. A particular advantage of the rear I/O capability is that there is no cabling on the CPU board, which makes it much easier to remove the CPU in the rack.

The rear I/O is installed in the back of the system into the backplane connectors P3, P4 and P5 in line with the CPU board.

The following figure illustrates the basic board layout of the CTM80-3 versions including their front panels. For further information regarding connector pinouts refer to the product's Quick Reference guide on the Kontron web site.



Figure A-1: CTM80-3 RIO Module with SCSI Configuration

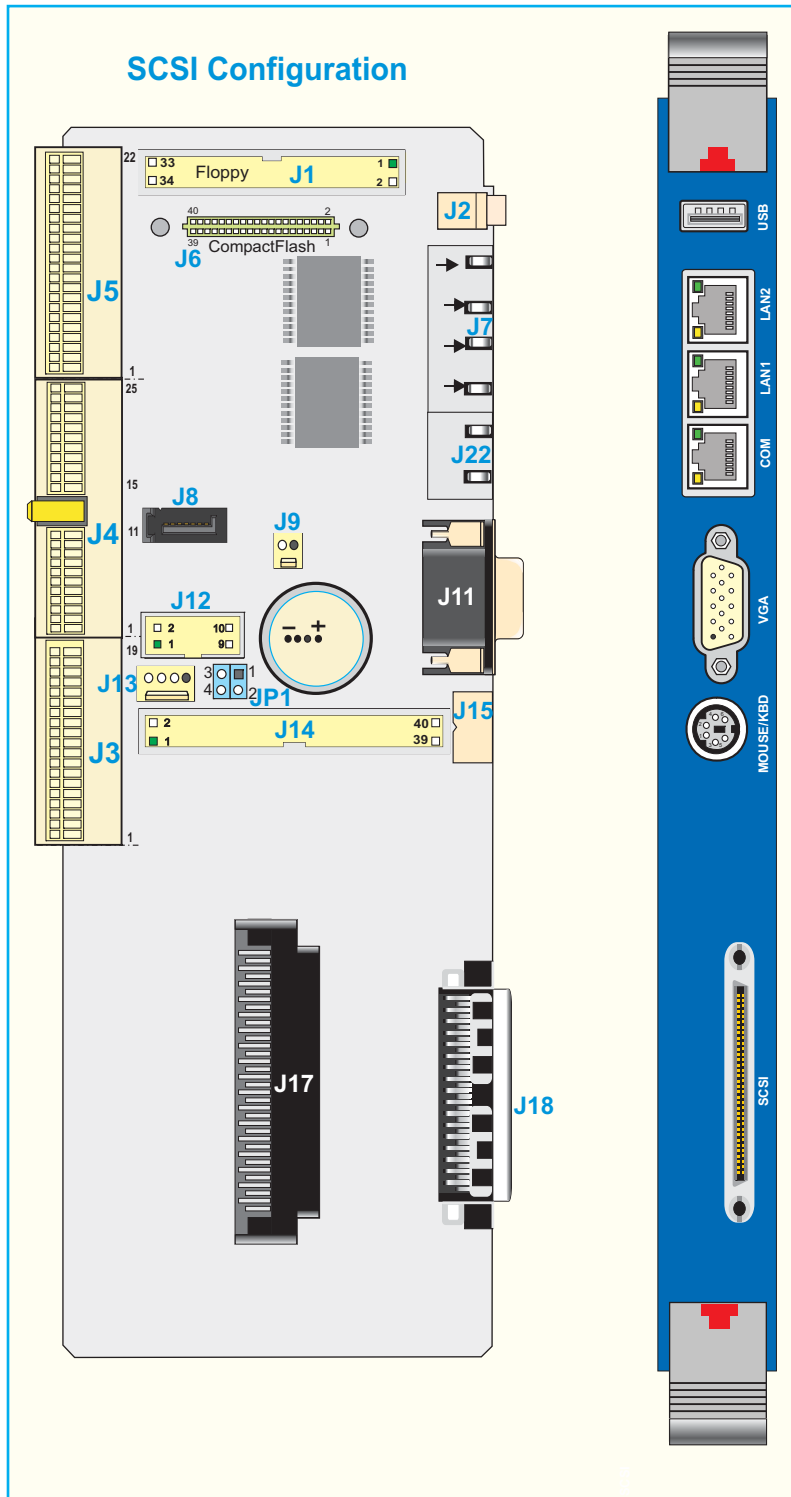

Note ...

The CTM80-3 RIO Module supports USB 2.0 protocol.





Figure A-2: CTM80-3 RIO Module with PATA or SATA Configuration

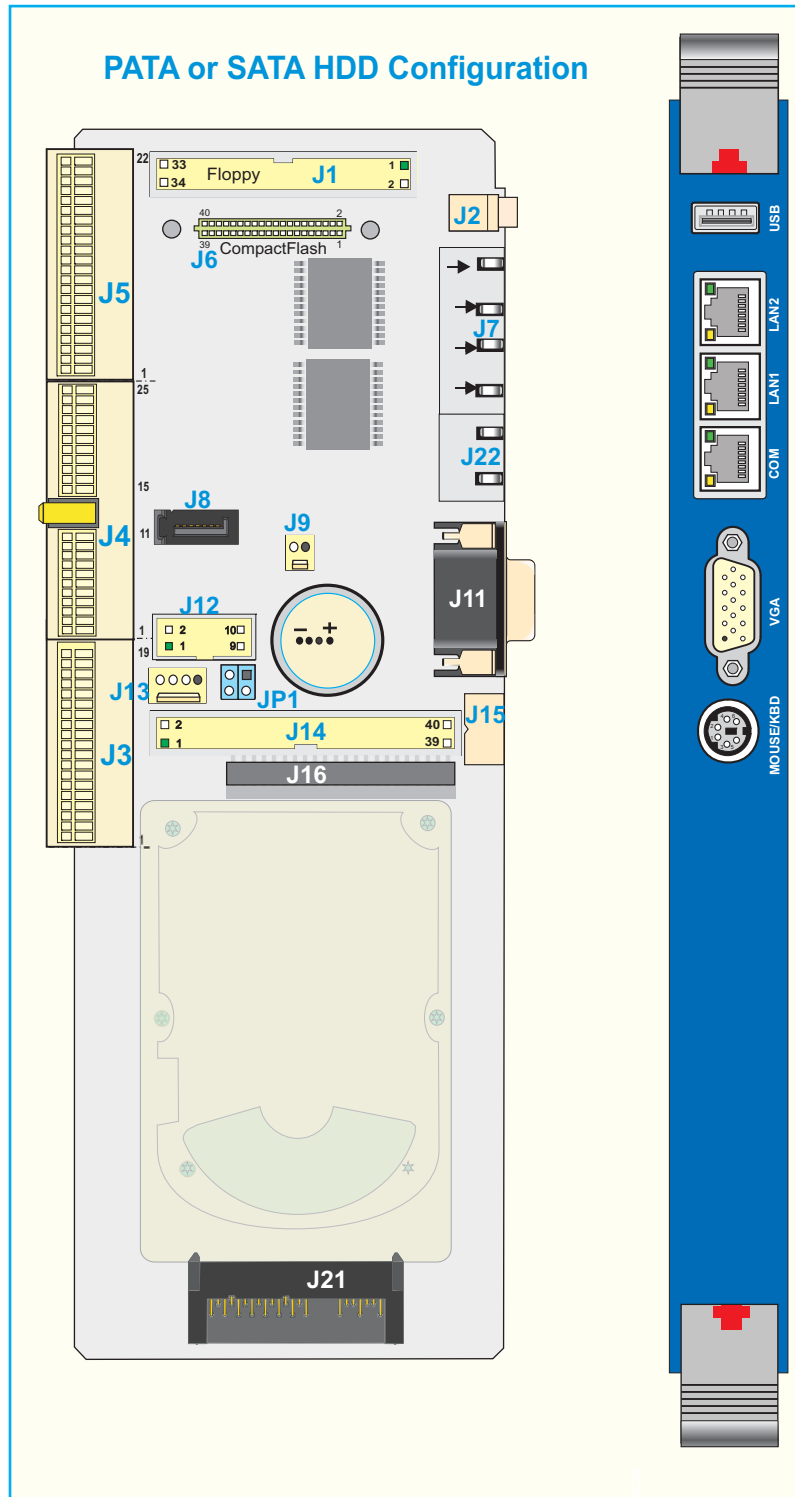

Note ...

The CTM80-3 RIO Module supports USB 2.0 protocol.



This page has been intentionally left blank.

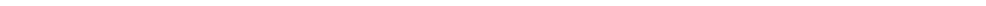



Appendix

B

CP6012-MK2.5SATA



This page has been intentionally left blank.





B. CP6012-MK2.5SATA Assembly Kit

The CP6012-MK2.5SATA assembly kit includes one CP6012-EXT-SATA module and the necessary components required for mounting the module on the board.

B.1 CP6012-EXT-SATA Module Overview

The CP6012-EXT-SATA module has been designed for use with the CP6012 6U CompactPCI board from Kontron and enables the user to connect an onboard 2.5" Serial ATA HDD or SSD to the CP6012.

B.2 Technical Specifications

Table B-1: CP6012-EXT-SATA Main Specifications

CP6012-EXT-SATA		SPECIFICATIONS
Interfaces	Board-to-Board Connectors	One 12-pin, male, board-to-board connector, J1
	Serial ATA Connector	One 22-pin Serial ATA connector, J2
General	Power Consumption	3.3 V or 5 V, depending on the hard disk Current 2.5" Serial ATA HDDs do not use 3.3 V.
	Temperature Range	Operating temp.: 0°C to +60°C Storage temp.: -55°C to +85°C
	Climatic Humidity	93% RH at 40°C, non-condensing (acc. to IEC 60068-2-78)
	Dimensions	54 mm x 27.5 mm
	Board Weight	ca.6 grams (without hard disk)

B.3 CP6012-EXT-SATA Functional Block Diagram

Figure B-1: CP6012-EXT-SATA Functional Block Diagram

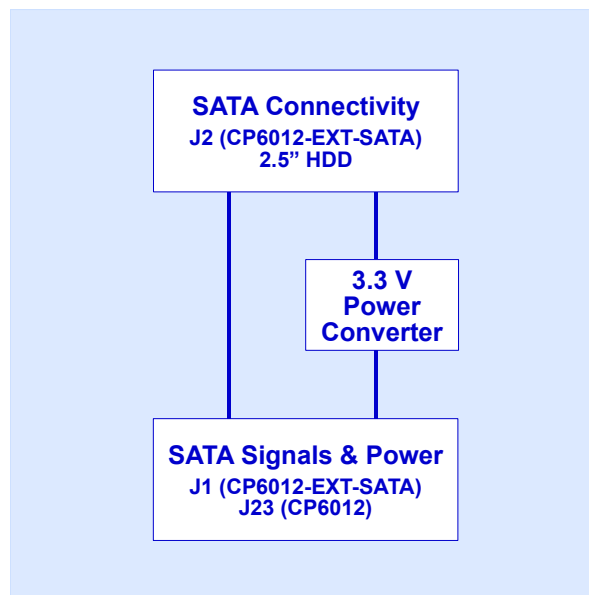



B.4 CP6012-EXT-SATA Module Layout

The CP6012-EXT-SATA Module includes one board-to-board connector, J1, and one SATA connector, J2.

B.4.1 CP6012-EXT-SATA Module Layout

Figure B-2: CP6012-EXT-SATA Module Layout

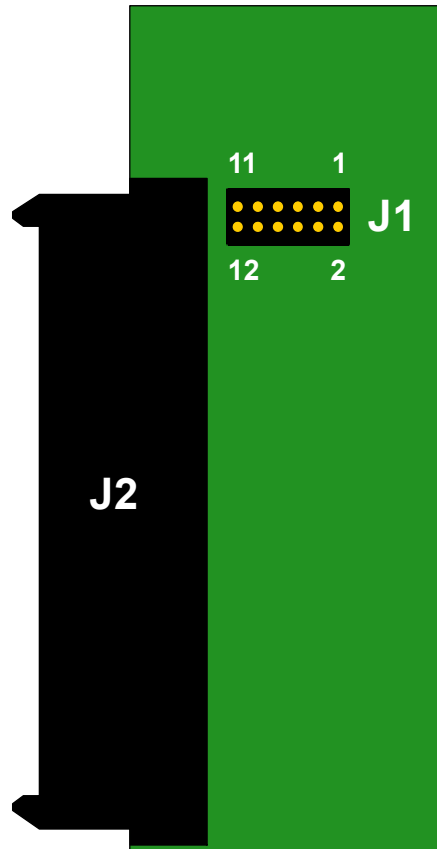



B.5 Module Interfaces

B.5.1 Board-to-Board Connectors J1 and J3

The board-to-board connector, J1, on the CP6012-EXT-SATA module is connected to the SATA extension connector, J23, on the CP6012.

Table B-2: Board-to-Board Connector J1 Pinout

PIN	SIGNAL	FUNCTION	I/O
1	SATA_RX0-	Differential Receive -	O
2	GND	Ground signal	--
3	SATA_RX0+	Differential Receive +	O
4	GND	Ground signal	--
5	GND	Ground signal	--
6	5V	5V power	--
7	SATA_TX0-	Differential Transmit -	I
8	GND	Ground signal	--
9	SATA_TX0+	Differential Transmit +	I
10	GND	Ground signal	--
11	GND	Ground signal	--
12	5V	5V power	--



B.5.2 SATA Connector J2

The SATA connector, J2, on the CP6012-EXT-SATA module is connected to the 2.5” SATA HDD mounted on the CP6012. The SATA connector is divided into two segments, a signal segment and a power segment.

Figure B-3: SATA Connector J2

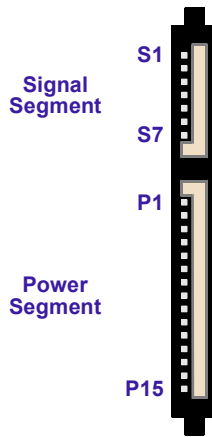

Table B-3: SATA Connector J2 Pinout

PIN	SIGNAL	FUNCTION	I/O
Signal Segment Key			
S1	GND	Ground signal	--
S2	SATA_TX0+	Differential Transmit+	I
S3	SATA_TX0-	Differential Transmit-	I
S4	GND	Ground signal	--
S5	SATA_RX0-	Differential Receive-	O
S6	SATA_RX0+	Differential Receive+	O
S7	GND	Ground signal	--
Signal Segment "L"			
Central Connector Polarizer			
Power Segment "L"			
P1	3.3V	3.3V power	--
P2	3.3V	3.3V power	--
P3	3.3V	3.3V power	--
P4	GND	Ground signal	--
P5	GND	Ground signal	--
P6	GND	Ground signal	--
P7	5V	5V power	--
P8	5V	5V power	--
P9	5V	5V power	--
P10	GND	Ground signal	--
P11	RES	Reserved	--
P12	GND	Ground signal	--
P13	12V (NC)	Not connected	--
P14	12V (NC)	Not connected	--
P15	12V (NC)	Not connected	--
Power Segment Key			

