

» EZ3-CMB Computer «



Getting Started

SD.DT.F99-0e - February 2012

Revision History

Publication Title:		EZ3-CMB Getting Started
Doc. ID:		SD.DT.F99-0e
Rev.	Brief Description of Changes	Date of Issue
0e	Initial Release	02-2012

Copyright © 2012 Kontron AG. All rights reserved. All data is for information purposes only and not guaranteed for legal purposes. Information has been carefully checked and is believed to be accurate; however, no responsibility is assumed for inaccuracies. Kontron and the Kontron logo and all other trademarks or registered trademarks are the property of their respective owners and are recognized. Specifications are subject to change without notice.

Proprietary Note

This document contains information proprietary to Kontron. It may not be copied or transmitted by any means, disclosed to others, or stored in any retrieval system or media without the prior written consent of Kontron or one of its authorized agents.

The information contained in this document is, to the best of our knowledge, entirely correct. However, Kontron cannot accept liability for any inaccuracies or the consequences thereof, or for any liability arising from the use or application of any circuit, product, or example shown in this document.

Kontron reserves the right to change, modify, or improve this document or the product described herein, as seen fit by Kontron without further notice.

Trademarks

This document may include names, company logos and trademarks, which are registered trademarks and, therefore, proprietary to their respective owners.

Environmental Protection Statement

This product has been manufactured to satisfy environmental protection requirements where possible. Many of the components used (structural parts, printed circuit boards, connectors, batteries, etc.) are capable of being recycled.

Final disposition of this product after its service life must be accomplished in accordance with applicable country, state, or local laws or regulations.



Environmental protection is a high priority with Kontron.

Kontron follows the DEEE/WEEE directive.

You are encouraged to return our products for proper disposal.

The Waste Electrical and Electronic Equipment (WEEE) Directive aims to:

- > reduce waste arising from electrical and electronic equipment (EEE)
- > make producers of EEE responsible for the environmental impact of their products, especially when they become waste
- > encourage separate collection and subsequent treatment, reuse, recovery, recycling and sound environmental disposal of EEE
- > improve the environmental performance of all those involved during the lifecycle of EEE

Conventions

This guide uses several types of notice: Note, Caution, ESD.



Note: this notice calls attention to important features or instructions.



Caution: this notice alert you to system damage, loss of data, or risk of personal injury.



ESD: This banner indicates an Electrostatic Sensitive Device.

All numbers are expressed in decimal, except addresses and memory or register data, which are expressed in hexadecimal. The prefix `0x` shows a hexadecimal number, following the `C` programming language convention.

The multipliers `k`, `M` and `G` have their conventional scientific and engineering meanings of $*10^3$, $*10^6$ and $*10^9$ respectively. The only exception to this is in the description of the size of memory areas, when `K`, `M` and `G` mean $*2^{10}$, $*2^{20}$ and $*2^{30}$ respectively.



When describing transfer rates, `k` `M` and `G` mean $*10^3$, $*10^6$ and $*10^9$ *not* $*2^{10}$ $*2^{20}$ and $*2^{30}$.

In PowerPC terminology, multiple bit fields are numbered from 0 to n, where 0 is the MSB and n is the LSB. PCI and CompactPCI terminology follows the more familiar convention that bit 0 is the LSB and n is the MSB.

Signal names ending with an asterisk (*) or a hash (#) denote active low signals; all other signals are active high.

Signal names follow the PICMG 2.0 R3.0 CompactPCI Specification and the PCI Local Bus 2.3 Specification.

For Your Safety

Your new Kontron product was developed and tested carefully to provide all features necessary to ensure its compliance with electrical safety requirements. It was also designed for a long fault-free life. However, the life expectancy of your product can be drastically reduced by improper treatment during unpacking and installation. Therefore, in the interest of your own safety and of the correct operation of your new Kontron product, you are requested to conform with the following guidelines.

High Voltage Safety Instructions



Warning!

All operations on this device must be carried out by sufficiently skilled personnel only.



Caution, Electric Shock!

Before installing a not hot-swappable Kontron product into a system always ensure that your mains power is switched off. This applies also to the installation of piggybacks. Serious electrical shock hazards can exist during all installation, repair and maintenance operations with this product. Therefore, always unplug the power cable and any other cables which provide external voltages before performing work.

Special Handling and Unpacking Instructions



ESD Sensitive Device!

Electronic boards and their components are sensitive to static electricity. Therefore, care must be taken during all handling operations and inspections of this product, in order to ensure product integrity at all times

Do not handle this product out of its protective enclosure while it is not used for operational purposes unless it is otherwise protected.

Whenever possible, unpack or pack this product only at EOS/ESD safe work stations. Where a safe work station is not guaranteed, it is important for the user to be electrically discharged before touching the product with his/her hands or tools. This is most easily done by touching a metal part of your system housing.

It is particularly important to observe standard anti-static precautions when changing piggybacks, ROM devices, jumper settings etc. If the product contains batteries for RTC or memory backup, ensure that the board is not placed on conductive surfaces, including anti-static plastics or sponges. They can cause short circuits and damage the batteries or conductive circuits on the board.

General Instructions on Usage

In order to maintain Kontron's product warranty, this product must not be altered or modified in any way. Changes or modifications to the device, which are not explicitly approved by Kontron and described in this manual or received from Kontron's Technical Support as a special handling instruction, will void your warranty.

This device should only be installed in or connected to systems that fulfill all necessary technical and specific environmental requirements. This applies also to the operational temperature range of the specific board version, which must not be exceeded. If batteries are present, their temperature restrictions must be taken into account.

In performing all necessary installation and application operations, please follow only the instructions supplied by the present manual.

Keep all the original packaging material for future storage or warranty shipments. If it is necessary to store or ship the board, please re-pack it as nearly as possible in the manner in which it was delivered.

Special care is necessary when handling or unpacking the product. Please consult the special handling and unpacking instruction on the previous page of this manual.

Table Of Contents

Chapter 1 - EZ3-CMB Overview	1
1.1 General Overview	1
1.2 Ordering Information	2
1.3 Receipt of the Equipment	2
1.3.1 Checking the Packages	2
1.3.2 Unpacking	2
1.3.3 Content	3
1.4 System Identification	4
Chapter 2 - Configuration	5
2.1 General Configuration	5
2.2 Chassis Monitoring Board (CMB)	8
Chapter 3 - Getting Started	9
3.1 Plug	9
3.2 Play	9
3.3 LEDs Description	10
3.4 System Supervision	11
3.4.1 Chassis Management by Command Line Interface	11
3.4.2 Chassis Management by SNMP	16
3.4.3 Chassis Management by HTTP	17
Chapter 4 - Technical Specifications	22
4.1 Dimensions	22
4.2 Weight	22
4.3 Power Supply	23
4.4 Environmental Conditions	23
Chapter 5 - Documentation	24
Chapter 6 - Known Limitations	25

List Of Figures

Figure 1 : EZ3-CMB Overview	1
Figure 2 : Delivery Content	3
Figure 3 : System Identification	4
Figure 4 : EZ3-CMB Front Panel Description	5
Figure 5 : EZ3-CMB Rear Panel Description	6
Figure 6 : EZ3-CMB Synoptic	7
Figure 7 : CMB Overview	8
Figure 8 : LEDs Overview on EZ3-CMB Rear Panel	10

Chapter 1 - EZ3-CMB Overview

1.1 General Overview



Figure 1 : EZ3-CMB Overview

EZ3-CMB system is made of the following building blocks:

- ▶ A chassis RTOPVPX-45200-C0 including:
 - ▶ CMB-F3W-00,
 - ▶ one fan,
 - ▶ one power supply unit providing 5V stby, +5V, +3.3V, +12V, -12V
 - ▶ one thermal sensor board (with 4 sensors)
 - ▶ one VPX backplane PCIe profile

1.2 Ordering Information

- Order Code: EZ3-CMB

1.3 Receipt of the Equipment

1.3.1 Checking the Packages

Inspecting the packages and verifying their condition is the responsibility of the customer and should be carried out upon delivery.

- Inspect the packages and check their condition:
 - ▶ no broken corners,
 - ▶ general state of the case (no rips or holes),
 - ▶ condition of the bands and the clips.
- If you wish to report any damage in transit, you should make out a full report, and also note the damage on the packing list that accompanies the equipment. Ensure that the report and the packing list are signed by yourself and also by the transport agent, and send a copy of these documents to:
 - ▶ the transport company,
 - ▶ Kontron.

1.3.2 Unpacking

Unpacking the equipment must be carried out under the supervision of a technician approved by Kontron.

- Open the package and take out the items one by one.



Two people should assist in the unpacking of the system unit, as it may be heavy.

- Inspect each item and make a note of any possible defects (scratches, marks or blemishes, damaged cables, etc.). If necessary, make a report of any damage or defects.
- Check the equipment against the packing list and report any missing items.



It is recommended that you keep the package and the anti-shock protection. This will be required if you decide to move your system or rack to a different site.

1.3.3 Content



Figure 2 : Delivery Content

The system (Order Code: EZ3-CMB) is made of:

	EZ3-CMB
One rack and associated boards	X
One power supply cable	X
Serial Cable KIT-RJ45DB9F	X
One Documentation CD-ROM CDDOC ID 12xxx	to be provided
EZ3-CMB Getting Started SD.DT.F99 (this document)	X

Table 1 : Delivery Content

1.4 System Identification

A specific Kontron Identification Label is available on the top of the system.



Figure 3 : System Identification

- > Model: System Order Code
- > Sn: Serial Number

Chapter 2 - Configuration

2.1 General Configuration



Figure 4 : EZ3-CMB Front Panel Description

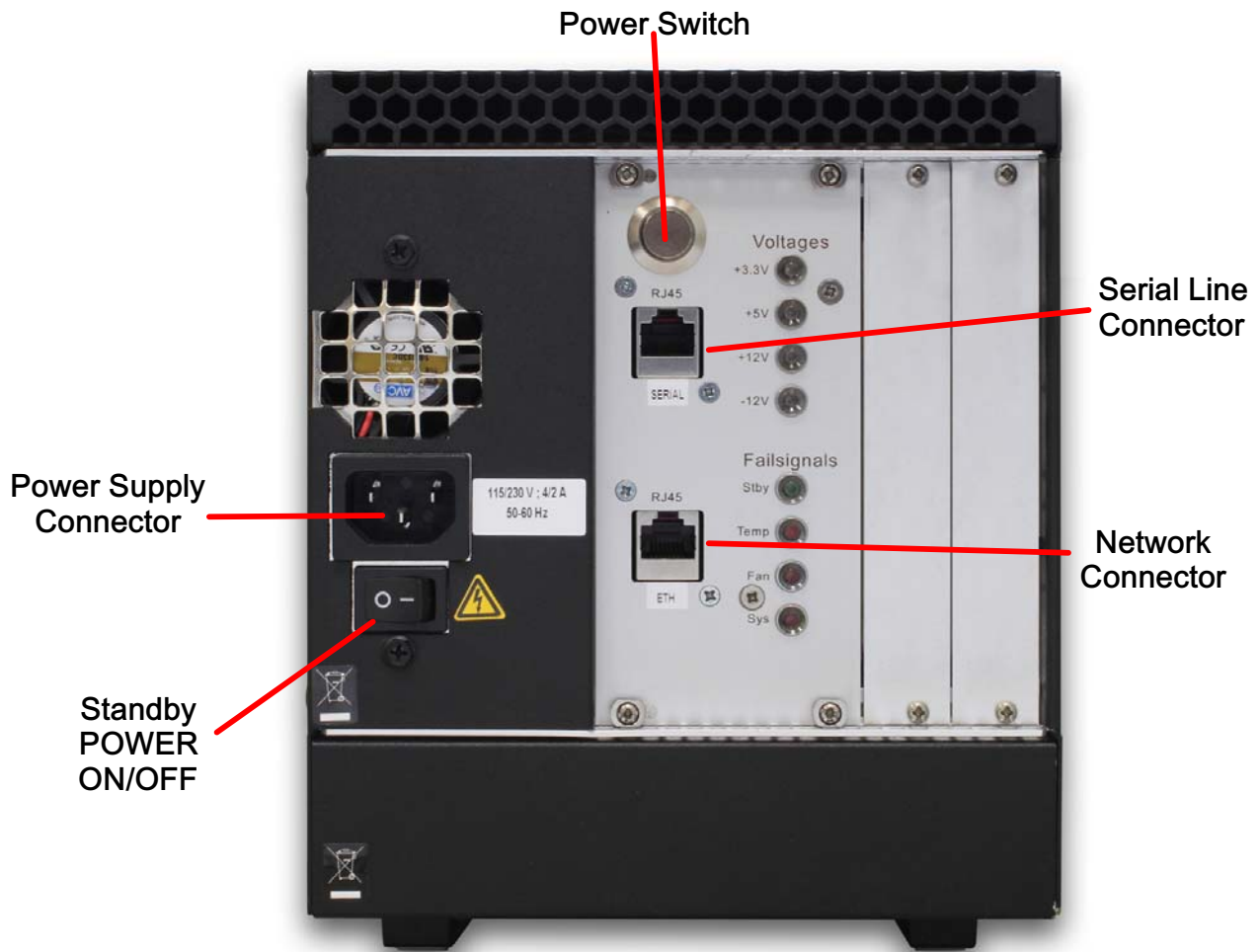

Figure 5 : EZ3-CMB Rear Panel Description

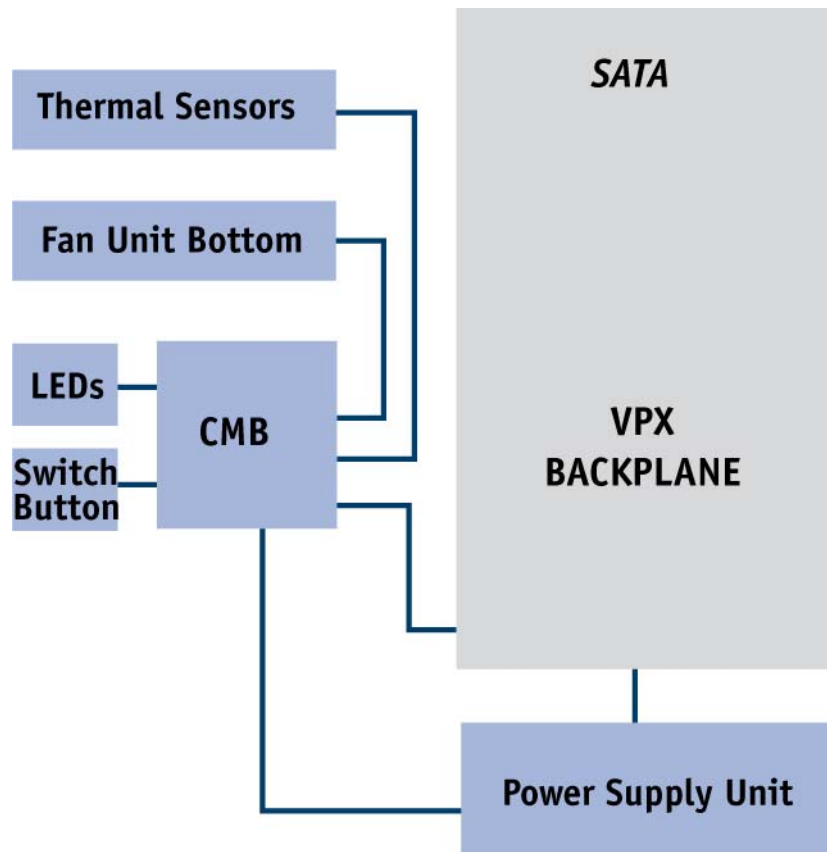

Figure 6 : EZ3-CMB Synoptic

2.2 Chassis Monitoring Board (CMB)

The chassis monitoring board implements the following features:

- Power supply monitoring and control,
- Temperatures monitoring via up to 8 thermal sensors,
- Fan speed monitoring and control,
- Alarm reporting: LEDs control for +3.3V, +5V, +12V, -12V, +5V stdby, temperature, fans, system error.
- Serial lines interface
- Ethernet interface
- TELNET, SNMP, HTTP protocols

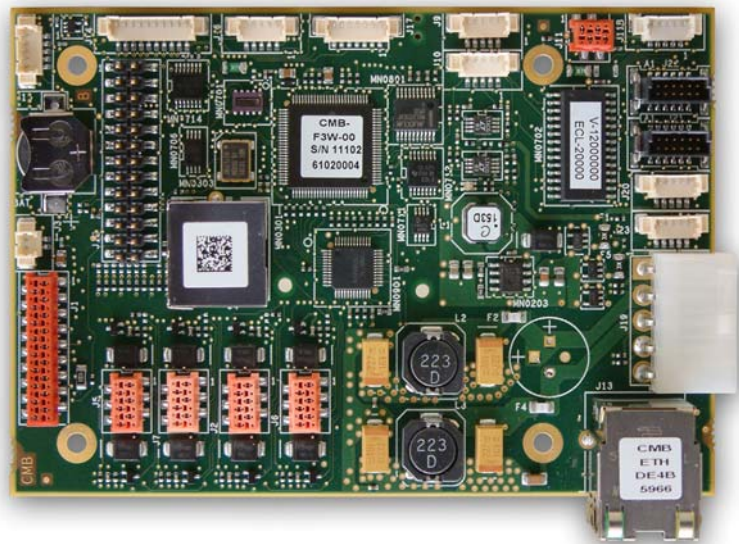

Figure 7 : CMB Overview

For more details, refer to “CMB User's Guide” (CA.DT.A82).

CMB can be accessed via serial line ("Serial" connector on front panel) or via Ethernet connection ("Network" RJ45 connector on front panel).

CMB serial line characteristics: 115200bps, 8 data bits, 1 STOP bit, no parity

Default CMB IP address:

Administrative account on CMB is:

- ▶ User account: cmb
- ▶ cmb password: KOMfabCMB

» Out of Band management:

An Ethernet cable must connect the "Network" RJ-45 connector on the front panel to the network of the monitoring system.

CMB IP address must be configured accordingly.

Chapter 3 - Getting Started

3.1 Plug

- Connect primary power supply

As soon as primary power supply is present, Chassis Monitoring Board supervises and controls the EZ3-CMB machine. The Green Led on the front panel indicates that the calculator is powered on and that the system BITs have been processed with no error.

A blinking green Standby Led indicates a system BIT issue.

Please refer to “Chassis Monitoring Board User’s Guide“ CA.DT.A82 for more information.

3.2 Play

- Connect the system as described in previous section 3.1 “Plug”

3.3 LEDs Description



Figure 8 : LEDs Overview on EZ3-CMB Rear Panel

Marking	Description	Color	Normal Use	Anomaly
+3.3V	3.3V Secondary voltage	Red/Green	Green	Red on +3.3V voltage threshold (min or max)
+5V	5V Secondary voltage	Red/Green	Green	Red on +5V voltage threshold (min or max)
+12V	12V Secondary Voltage	Red/Green	Green	Red on +12V voltage threshold (min or max)
-12V	-12V Secondary Voltage	Red/Green	Green	Red on -12V voltage threshold (min or max)
Stby	5V standby Voltage	Green	Green	Led off: power supply issue on +5Vstandby Green Blinking led: PBIT issue
Temp	Temperature Warning	Red	Off	Red on temperature threshold
Fan	Fan Warning	Red	Off	Red when one fan does not run at the driven speed
Sys	System Warning	Red	Off	This led is lit off on power supply provided the generating event has disappeared

For a detailed descriptions of the leds on the boards refer to their User's Guide.

3.4 System Supervision

The chassis management is processed by the CMB. For a detailed description of this board refer to “User's Guide” CA.DT.A82.

By default the CMB board is configured to reply to Telnet, SNMP, HTTP requests at a fixed IP address. This default configuration can be changed by the serial interface.



In the following screenshots given as examples, a VX3035 board is plugged in EZ3-CMB chassis.

3.4.1 Chassis Management by Command Line Interface

» CMB Startup

As soon as the standby power supply is ON, the CMB starts up.

```
=====
MONITORING SOFTWARE 3.0 (build: Jan 19 2012)
VPDs: LOADING ...
WARNING: VPD USER unavailable
CONF: LOADING ...
PASSWORDS: LOADING ...
MAIN TASK started
TEMPERATURE TASK started
5 sensors : CMB, VPX slot #1, VPX slot #2, VPX s1LGB
Cot #3, VPX slot #4
ED TASK started
LED BLINKING TASK started
FAN TACHO TAMBSK started
FAN PWM TASK started
PIO IN TASK started
GPIO OUT TASK started
GPIO USER TASK started
VOLTAGE TASK started
OARD TASK started
== ALL T ASKS STARTED ==
Shell (build: Dec 12 2011)
Copyright (c) 2008 Freescale Semiconductor;
Copyright (c) 2010 Kontron Modular Computers;
NETWORK TASK started
NETWORK: MAC
```

```

Username: address is 00:00:de:40:41:62
NETWORK: IP method is : STATIC
NETWORK: IP address: 172.20.161.34
NETWORK: IP netmask: 255.255.255.0
NETWORK: IP gateway: 172.20.161.46
NETWORK: configuration done :
  IP address : 172.20.161.34
  IP mask    : 255.255.255.0
  IP gateway : 172.20.161.46
NETWORK: starting telnet server
NETWORK: starting HTTP server
SNMP TASK started
SNMP: starting SNMP server
SNMP: starting SNMP notifications

Username:

```

From now the command line interface is available via both the serial line and a Telnet session.

» Check VPD

```

cmb@CMB> show vpd cmb
----- VPDs CMB -----
Part number   : CMB-F3W-00
Serial number  : 1111091030046
Variant       : 12000000
EC Level      : 2001
PCB Level     : B
MAC address   : 00:00:de:40:41:62
Temperature sensor(s) : 1
  CMB : bus=0, addr=48
Rack I2C bus on standby power : no
cmb@CMB> show vpd rack
----- VPDs RACK -----
Part number   : RTOPVPX-4S200-C0
Serial number  : 10/C313501-10
EC Level      : PROTO
Fan(s)        : 1
  Bottom : port 1, max 3000 RPM, min 60%, PWM@min 30%
           tacho (2 pulses per revolution), no pwm wire
Temperature sensor(s) : 4
  VPX slot #1 : bus=1, addr=4b
  VPX slot #2 : bus=1, addr=4a
  VPX slot #3 : bus=1, addr=49
  VPX slot #4 : bus=1, addr=48
Power supplies (PSUs) : 4
  PSU 3V3 : 3V3 rail, MON[-], CTL[-], GLOBCTL[0], GLOBCTL=ENABLE
  PSU 5V  : 5V rail, MON[-], CTL[-], GLOBCTL[0], GLOBCTL=ENABLE
  PSU 12V : 12V rail, MON[-], CTL[-], GLOBCTL[0], GLOBCTL=ENABLE
  PSU -12V : -12V rail, MON[-], CTL[-], GLOBCTL[0], GLOBCTL=ENABLE

```

```

Acfail used : none
Voltages available : 5VSB1 3V3 5V 12V -12V
Power button : Switch connected to CMB
cmb@CMB> show vpd system
----- VPDs SYSTEM -----
Part number   : EZ3-VX3035-0C-L
Serial number  : 0001
EC Level      : PROTO
Temperature limits :
Sensor #0 : CMB : min:---C, max: 70C
Sensor #1 : VPX slot #1 : min:---C, max: 70C
Sensor #2 : VPX slot #2 : min:---C, max: 70C
Sensor #3 : VPX slot #3 : min:---C, max: 70C
Sensor #4 : VPX slot #4 : min:---C, max: 70C
Power-off if temperature above high limits : no
Power-off if temperature under low limits : no
Fan RPM limits :
Fan #0 : Bottom : min: 45%, max:---%
Fan trip points :
60% @ 25C
100% @ 55C
Voltage limits (mV) :
 3V3 : min: 3100mV, max: 3700mV
  5V : min: 4750mV, max: 5500mV
 12V : min: 10200mV, max: 13800mV
-12V : min:-13800mV, max:-10200mV
5VSB : min: 4750mV, max: 5500mV
cmb@CMB>

```

» Chassis Temperature

```

cmb@CMB> show temp
----- TEMPERATURES -----
SENSOR #0 : CMB : 32 C (min:---, max: 70)
SENSOR #1 : VPX slot #1 : 26 C (min:---, max: 70)
SENSOR #2 : VPX slot #2 : 25 C (min:---, max: 70)
SENSOR #3 : VPX slot #3 : 24 C (min:---, max: 70)
SENSOR #4 : VPX slot #4 : 23 C (min:---, max: 70)

```

Thermal sensor #0 is located on the CMB.

Thermal sensors #1 to #8 are located above the VPX slots and above Power supply area.

» Secondary Power Supplies

```

----- PSUs -----
PSU 3V3 : 3V3 : UNKNOWN
PSU 5V : 5V : UNKNOWN
PSU 12V : 12V : UNKNOWN
PSU -12V : -12V : UNKNOWN

```

» Fans Supervision

```
cmb@CMB> show fan
----- FANS -----
FAN #0 : Bottom : 1972 RPM (min:1350, max:----)  AUTO SPEED  61% (pwm 32%)
```

» Alarms

State of the alarms (reflecting the state of the LEDs on the front panel) can be displayed with following command:

```
cmb@CMB> show led
----- LEDs -----
3.3V : GREEN
5V   : GREEN
12V  : GREEN
-12V : GREEN
STBY : GREEN
TEMP : OFF
FAN  : OFF
SYS  : OFF
```

» PBIT/CBIT

The state of CMB board is permanently supervised and the status is available with the command:

```
cmb@CMB> show bit
----- PBIT/CBIT report -----
Software           : OK
Configuration      : OK
I2C GPIO expander #1 : OK
I2C GPIO expander #2 : OK
I2C GPIO expander #3 : OK
I2C GPIO expander #4 : OK
I2C EEPROM         : OK
I2C Temp sensor #0 (CMB) : OK
I2C Temp sensor #1 (VPX slot #1) : OK
I2C Temp sensor #2 (VPX slot #2) : OK
I2C Temp sensor #3 (VPX slot #3) : OK
I2C Temp sensor #4 (VPX slot #4) : OK
```

» Plugged Chassis Boards

```
cmb@CMB> show board
----- BOARDS -----
Boards detected :
Slot 01: Board:VX3035 Power:ON LastrST:POWER-ON PSU:OK
        BootState:OS-BOOT Reset:OFF
        Boot watchdog : OFF, STOPPED, Timeouts:0

Boot watchdog current settings :
Timeout (sec, 0=off) : 0
Max reset count      : 0
```

» CMB Conf

```
cmb@CMB> show conf
----- NETWORK config -----
IP method      : STATIC
IP static address: 172.20.161.34
IP static netmask: 255.255.255.0
IP static gateway: 172.20.161.46
Telnet server  : ENABLED
HTTP server    : ENABLED
SNMP server    : ENABLED
SNMP notify    : V2 INFORM
  Retry period : 500 (mS)
  Retry count  : 2
  Target IP #1 : 172.20.161.129
  Target IP #2 : 0.0.0.0
  Target IP #3 : 0.0.0.0
----- MISC config -----
Shell on COM2 : DISABLED
----- BOARD config -----
Boot watchdog :
Slot list      :
Timeout (sec, 0=off) : 0
Max reset count : 0
Default NVMRO level : 0
Default GDISC level : 0
```

» Voltage Levels

```
cmb@CMB> show volt
----- VOLTAGES -----
3V3  : 3350 mV (min: 3100, max: 3700)
5V   : 5104 mV (min: 4750, max: 5500)
12V  : 12117 mV (min: 10200, max: 13800)
-12V : -11542 mV (min:-13800, max:-10200)
5VSB1 : 5157 mV (min: 4750, max: 5500)
```

To close connection of the CMB board type:

```
cmb@CMB> exit
```

» Current Thermal Strategy

When a thermal sensor detects that temperature exceeds the threshold value (+70°C), CMB stops secondary power supplies, lighth on the red tempature LED and the red system LED.

The red temperature alarm remains ON as long as temperature has not decreased under threshold value. In this case, the red system alarm remains ON to memorize the alarm threshold. The operator can now push the ON/OFF button of the rack to start the system. The alarm system will be lighthed OFF.

The operator can not start the system as long as the Temperature alarm is ON.

3.4.2 Chassis Management by SNMP

» SNMP Browser

The chassis can be managed through SNMP protocol by using a SNMP browser. An Open Source browser can be get at the following address:

<http://sourceforge.net/projects/snmpb/>

SnmpB is an SNMP MIB browser written in QT. It supports SNMPv1, SNMPv2c & SNMPv3. SnmpB can browse/edit/load/add MIB files and can query SNMP agents. It also supports agent discovery, trap events, and graph plotting.

» CMB-MIB

SNMP information provided by the CMB is defined in the CMB-MIB file:

<http://emea.kontron.com/products/systems+and+platforms/vpx+systems+and+platforms/accessories/cmb.html>



This SNMP interface can be improved according to user's needs by upgrading the CMB firmware.

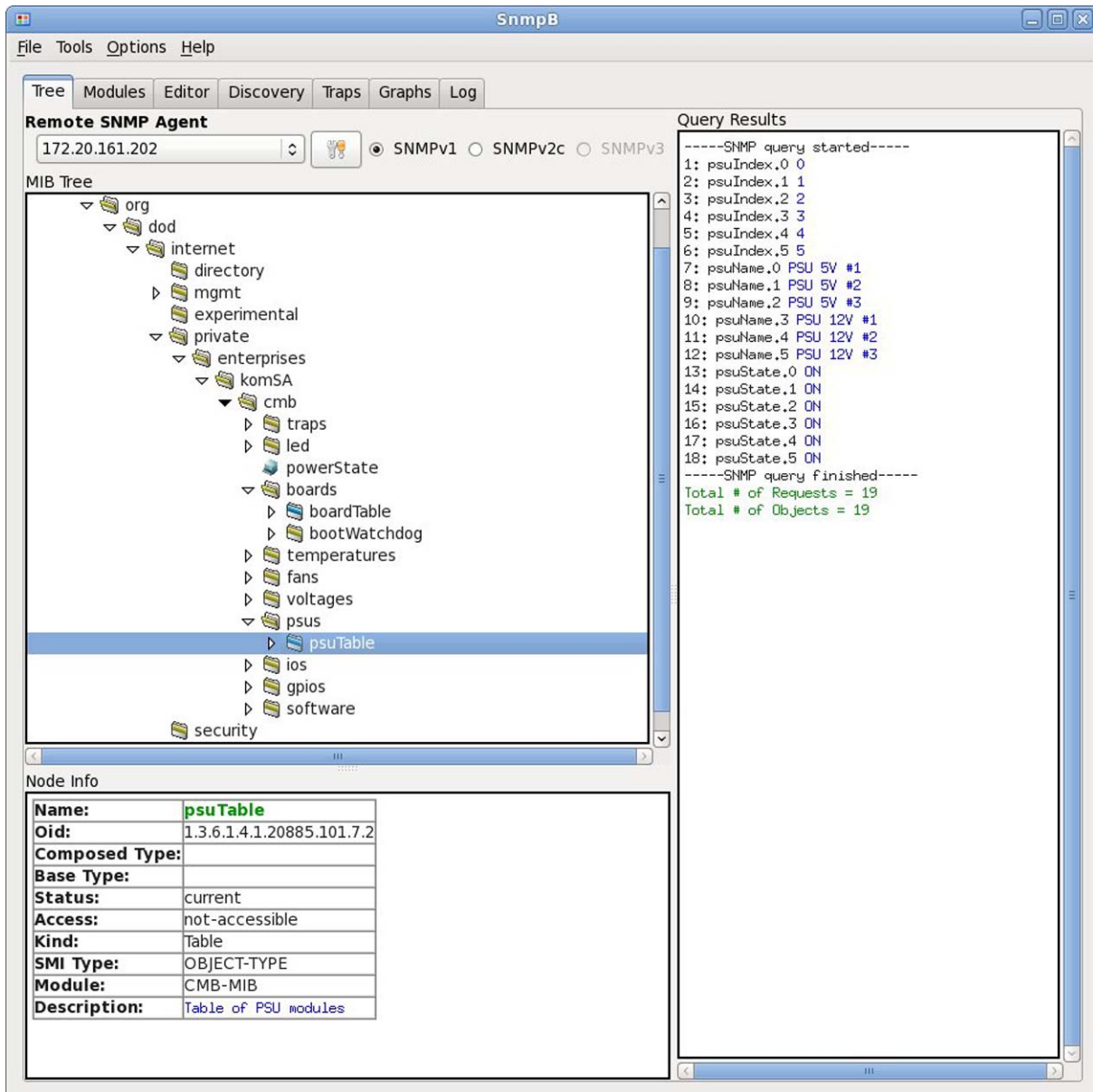

3.4.3 Chassis Management by HTTP

The chassis can be monitored and managed via CMB HTTP interface.

Basic implementation can be seen herebelow.



This interface can be improved according to user's needs by upgrading CMB firmware

» Before Power ON



Power

ON OFF

LEDs

+3V3	OFF
+5V	OFF
+12V	OFF
-12V	OFF
STBY	GREEN
TEMP	OFF
FAN	OFF
SYS	OFF

» The chassis is powered



» Chassis Sensors Tab

The screenshot shows the 'SENSORS' page in a Mozilla Firefox browser. The page is divided into four quadrants, each containing a table of sensor data.

VOLTAGES

Power rail	mV	Low Limit	High Limit
+3V3	3345	3100	3700
+5V	5044	4750	5500
+12V	12216	10200	13800
-12V	-11783	-13800	-10200
+5VSB1	5157	4750	5500

PSUs

PSU	Power rail	State
PSU 3V3	3V3	UNKNOWN
PSU 5V	5V	UNKNOWN
PSU 12V	12V	UNKNOWN
PSU -12V	-12V	UNKNOWN

TEMPERATURES

Sensor	°C	Low Limit	High Limit
CMB	33	---	70
VPX slot #1	27	---	70
VPX slot #2	25	---	70
VPX slot #3	25	---	70
VPX slot #4	24	---	70

FANS

Fan	RPM	Low Limit	High Limit	Mode	%
Bottom	1999	1350	---	AUTO SPEED	62

At the bottom of the page, there are two buttons: [BACK](#) and [RELOAD](#).

» Boards Tab

By default, a board can be maintained in POWER OFF (SW2.2=ON) after the power supply is ON. Then it can be started selectively from the CMB by activating "Power: on" button in the following menu.

The screenshot shows the 'BOARDS' page in a Mozilla Firefox browser. The page displays the status of a board and its boot watchdog settings.

Boards

Slot	Board Type	State
1	VX3035	Power: on <input checked="" type="radio"/> standby <input type="radio"/> LastRST:POWER-ON PSU:OK BootState:OS-BOOT Reset: on <input type="radio"/> off <input checked="" type="radio"/>

Change

Boot Watchdog

Slot	Enable	Current state	Timeout count
1	on <input type="radio"/> off <input checked="" type="radio"/>	STOPPED	0

Timeout (seconds)
 Max reset count

Change

At the bottom of the page, there are two buttons: [BACK](#) and [RELOAD](#).

» I/O Tab

I/O inputs

sysreset	1
acfail	1
sysfail	1
nvmmro	0
gdisc	0

I/O outputs

sysreset	0	1
acfail	0	1
sysfail	0	1
nvmmro	0	1
gdisc	0	1
mrst1	0	1
mrst2	0	1
mrst3	0	1
mrst4	0	1
mrst5	0	1
mrst6	0	1
mrst7	0	1
mrst8	0	1

GPIOs

Name	Level	Config	IT config	IT count
GPIO0	0	out@0 <input type="radio"/> out@1 <input type="radio"/> in <input checked="" type="radio"/>	on <input type="radio"/> off <input checked="" type="radio"/>	---
GPIO1	0	out@0 <input type="radio"/> out@1 <input type="radio"/> in <input checked="" type="radio"/>	on <input type="radio"/> off <input checked="" type="radio"/>	---
GPIO2	1	out@0 <input type="radio"/> out@1 <input type="radio"/> in <input checked="" type="radio"/>	on <input type="radio"/> off <input checked="" type="radio"/>	---
GPIO3	0	out@0 <input type="radio"/> out@1 <input type="radio"/> in <input checked="" type="radio"/>	on <input type="radio"/> off <input checked="" type="radio"/>	---
GPIO4	0	out@0 <input type="radio"/> out@1 <input type="radio"/> in <input checked="" type="radio"/>	on <input type="radio"/> off <input checked="" type="radio"/>	---
GPIO5	0	out@0 <input type="radio"/> out@1 <input type="radio"/> in <input checked="" type="radio"/>	on <input type="radio"/> off <input checked="" type="radio"/>	---
GPIO6	0	out@0 <input type="radio"/> out@1 <input type="radio"/> in <input checked="" type="radio"/>	on <input type="radio"/> off <input checked="" type="radio"/>	---
GPIO7	0	out@0 <input type="radio"/> out@1 <input type="radio"/> in <input checked="" type="radio"/>	on <input type="radio"/> off <input checked="" type="radio"/>	---

Change

Change

BACK RELOAD

» Status Tab

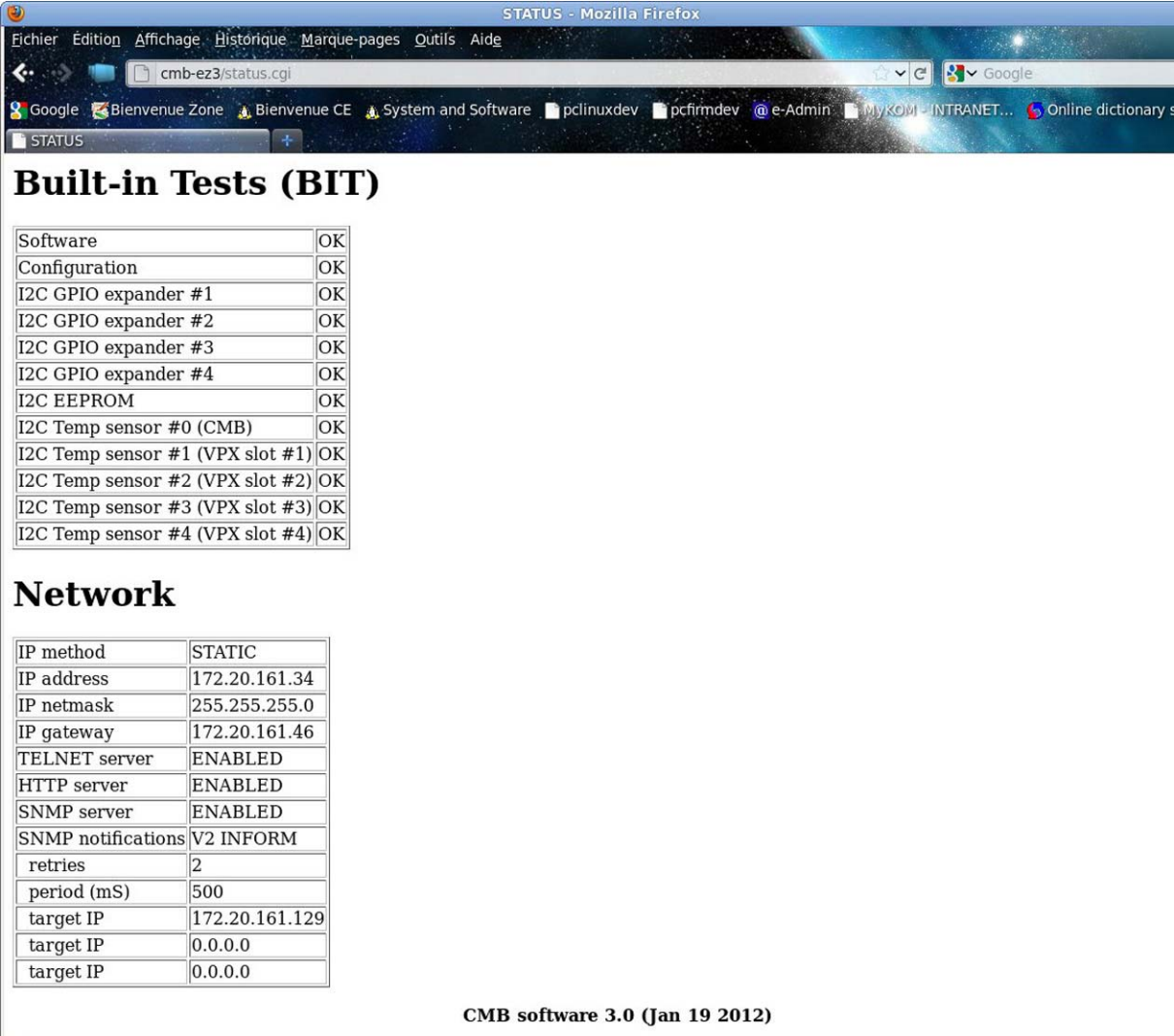

The screenshot shows a web browser window titled "STATUS - Mozilla Firefox" with the address bar displaying "cmb-ez3/status.cgi". The page content is as follows:

Built-in Tests (BIT)

Software	OK
Configuration	OK
I2C GPIO expander #1	OK
I2C GPIO expander #2	OK
I2C GPIO expander #3	OK
I2C GPIO expander #4	OK
I2C EEPROM	OK
I2C Temp sensor #0 (CMB)	OK
I2C Temp sensor #1 (VPX slot #1)	OK
I2C Temp sensor #2 (VPX slot #2)	OK
I2C Temp sensor #3 (VPX slot #3)	OK
I2C Temp sensor #4 (VPX slot #4)	OK

Network

IP method	STATIC
IP address	172.20.161.34
IP netmask	255.255.255.0
IP gateway	172.20.161.46
TELNET server	ENABLED
HTTP server	ENABLED
SNMP server	ENABLED
SNMP notifications	V2 INFORM
retries	2
period (mS)	500
target IP	172.20.161.129
target IP	0.0.0.0
target IP	0.0.0.0

CMB software 3.0 (Jan 19 2012)

Chapter 4 - Technical Specifications

4.1 Dimensions

Width	169.64 mm
Depth	298.1 mm
High	191 mm

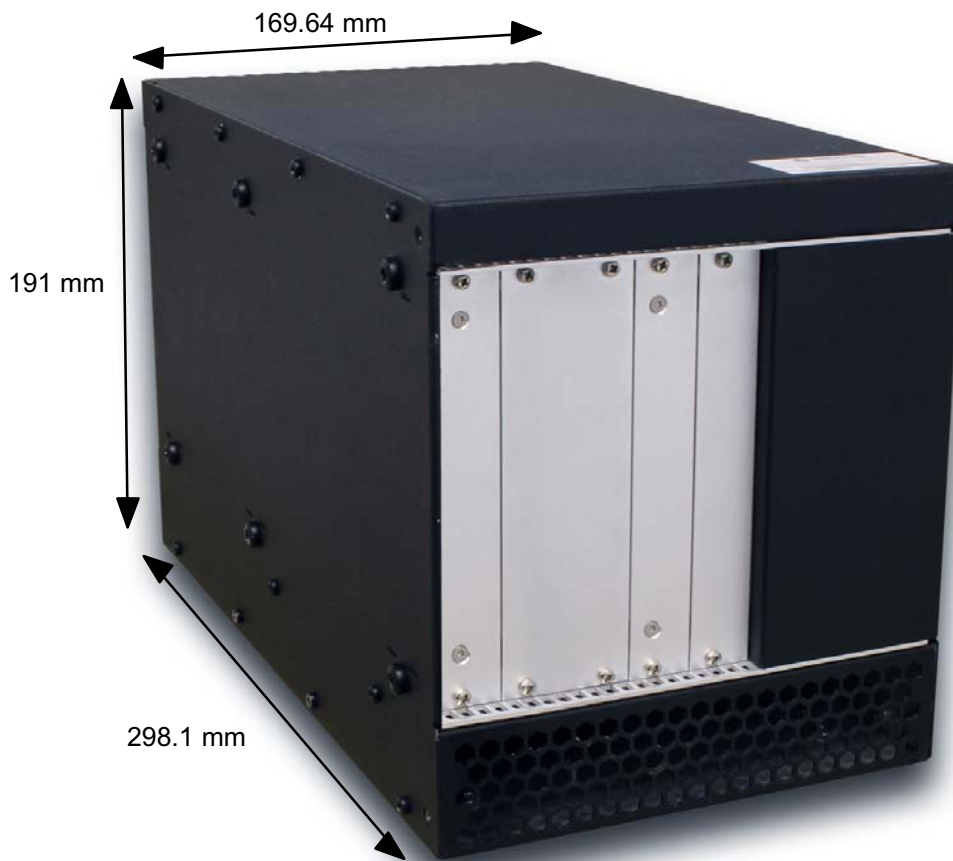

4.2 Weight

- 5.0 Kgs (approximately)

4.3 Power Supply

- Input Voltage : 110V-240V 47-63Hz
- Maximal Power : 200W
- Output Voltage and available current:

+ 3.3V	0-14A
+ 5 V	23A
+ 12V	12A
-12V	0-0.5A
5VSB	0-2A

4.4 Environmental Conditions

- Operating: 0° to 50° C
- Storage: -20° to 80° C

Chapter 5 - Documentation

The hardware and software documentations are available on the CD-ROM provided with the system.

SYSTEM		
EZ3-CMB	SD.DT.F99-0e	Getting Started
BOARDS		
CMB	CA.DT.A82-6e	Chassis Monitoring Board - User's Guide

Chapter 6 - Known Limitations

No known limitations.

Bugzilla Bug	Description

MAILING ADDRESS

Kontron Modular Computers S.A.S.
150 rue Marcelin Berthelot - BP 244
ZI TOULON EST
83078 TOULON CEDEX - France

TELEPHONE AND E-MAIL

+33 (0) 4 98 16 34 00
sales@kontron.com
support-kom-sa@kontron.com

For further information about other Kontron products, please visit our Internet web site:
www.kontron.com.