



# KBox A-151-RPL

User Guide Rev. 1.0

Doc. ID 1075-3773

This page has been intentionally left blank

# KBox A-151-RPL – User Guide

## Disclaimer

Kontron would like to point out that the information contained in this user guide may be subject to alteration, particularly as a result of the constant upgrading of Kontron products. This document does not entail any guarantee on the part of Kontron with respect to technical processes described in the user guide or any product characteristics set out in the user guide. Kontron assumes no responsibility or liability for the use of the described product(s), conveys no license or title under any patent, copyright or mask work rights to these products and makes no representations or warranties that these products are free from patent, copyright or mask work right infringement unless otherwise specified. Applications that are described in this user guide are for illustration purposes only. Kontron makes no representation or warranty that such application will be suitable for the specified use without further testing or modification. Kontron expressly informs the user that this user guide only contains a general description of processes and instructions which may not be applicable in every individual case. In cases of doubt, please contact Kontron.

This user guide is protected by copyright. All rights are reserved by Kontron. No part of this document may be reproduced, transmitted, transcribed, stored in a retrieval system, or translated into any language or computer language, in any form or by any means (electronic, mechanical, photocopying, recording, or otherwise), without the express written permission of Kontron. Kontron points out that the information contained in this user guide is constantly being updated in line with the technical alterations and improvements made by Kontron to the products and thus this user guide only reflects the technical status of the products by Kontron at the time of publishing.

Brand and product names are trademarks or registered trademarks of their respective owners.

©2026 by Kontron Europe GmbH

Kontron Europe GmbH  
Gutenbergstraße 2  
85737 Ismaning  
Germany  
[www.kontron.com](http://www.kontron.com)

## Intended Use

This device and associated software are not designed, manufactured or intended for use or resale for the operation of nuclear facilities, the navigation, control or communication systems for aircraft or other transportation, air traffic control, life support or life sustaining applications, weapons systems, or any other application in a hazardous environment, or requiring fail-safe performance, or in which the failure of products could lead directly to death, personal injury, or severe physical or environmental damage (collectively, “high risk applications”).

You understand and agree that your use of Kontron devices as a component in High Risk Applications is entirely at your risk. To minimize the risks associated with your products and applications, you should provide adequate design and operating safeguards. You are solely responsible for compliance with all legal, regulatory, safety, and security related requirements concerning your products. You are responsible to ensure that your systems (and any Kontron hardware or software components incorporated in your systems) meet all applicable requirements. Unless otherwise stated in the product documentation, the Kontron device is not provided with error-tolerance capabilities and cannot therefore be deemed as being engineered, manufactured or setup to be compliant for implementation or for resale as device in High Risk Applications. All application and safety related information in this document (including application descriptions, suggested safety measures, suggested Kontron products, and other materials) is provided for reference only.

---

**NOTICE**

You find the most recent version of the “General Safety Instructions” online in the download area of this product.

---

---

**NOTICE**

This product is not intended for use or suited for storage or operation in corrosive environments, in particular under exposure to sulfur and chlorine and their compounds. For information on how to harden electronics and mechanics against these stress conditions, contact Kontron Support.

---

## Revision History

Revision	Brief Description of Changes	Date of Issue	Author
1.0	Initial version	08-May-2026	CW

## Terms and Conditions

Kontron warrants products in accordance with defined regional warranty periods. For more information about warranty compliance and conformity, and the warranty period in your region, visit [www.kontron.com/terms-and-conditions](http://www.kontron.com/terms-and-conditions).

Kontron sells products worldwide and declares regional General Terms & Conditions of Sale, and Purchase Order Terms & Conditions. Visit [www.kontron.com/terms-and-conditions](http://www.kontron.com/terms-and-conditions).

For contact information, refer to the corporate offices contact information on the last page of this user guide or visit our website [CONTACT US](#).

## Customer Support

Find Kontron contacts by visiting [www.kontron.com/support-and-services](http://www.kontron.com/support-and-services).

## Customer Service

As a trusted technology innovator and global solutions provider, Kontron extends its embedded market strengths into a services portfolio allowing companies to break the barriers of traditional product lifecycles. Proven product expertise coupled with collaborative and highly-experienced support enables Kontron to provide exceptional peace of mind to build and maintain successful products.

For more details on Kontron's service offerings such as: enhanced repair services, extended warranty, Kontron training academy, and more visit [www.kontron.com/support-and-services](http://www.kontron.com/support-and-services).

## Customer Comments

If you have any difficulties using this user guide, discover an error, or just want to provide some feedback, contact [Kontron support](#). Detail any errors you find. We will correct the errors or problems as soon as possible and post the revised user guide on our website.

# Symbols

The following symbols may be used in this user guide



**DANGER** indicates a hazardous situation which, if not avoided, will result in death or serious injury.



**WARNING** indicates a hazardous situation which, if not avoided, could result in death or serious injury.



**NOTICE** indicates a property damage message.



**CAUTION** indicates a hazardous situation which, if not avoided, may result in minor or moderate injury  
**ATTENTION** indique une situation dangereuse qui, si elle n'est pas évitée, peut entraîner des blessures mineures ou modérées.



### Electric Shock!

This symbol and title warn of hazards due to electrical shocks (> 60 V) when touching products or parts of products. Failure to observe the precautions indicated and/or prescribed by the law may endanger your life/health and/or result in damage to your material.



### ESD Sensitive Device!

This symbol and title inform that the electronic boards and their components are sensitive to static electricity. Care must therefore be taken during all handling operations and inspections of this product in order to ensure product integrity at all times.



### Caution: HOT Surface!

Do NOT touch! Allow to cool before servicing.

### Attention : Surface CHAUDE !

Ne pas toucher ! Laissez refroidir avant de procéder à l'entretien.



### Caution: Laser!

This symbol and title inform of the risk of exposure to laser beam and light emitting devices (LEDs) from an electrical device. Eye protection per manufacturer notice shall be reviewed before servicing.



### High sound pressure!

symbol and title inform of the risk of hearing damage due to high sound pressure. Do not listen at high volume levels for long periods of time.



**Security**

This symbol indicates general information and guidelines regarding the product's cyber security to ensure secure installation, operation, maintenance and disposal of the product within the user's end environment.

---



This symbol indicates general information about the product and the user guide.

---



This symbol precedes helpful hints and tips for daily use.

---

## For Your Safety

Your new Kontron product was developed and tested carefully to provide all the features necessary to ensure its compliance with electrical safety requirements. It was also designed for a long fault-free life. However, the life expectancy of your product can be drastically reduced by improper treatment during unpacking and installation. Therefore, in the interest of your own safety and of the correct operation of your new Kontron product, you are requested to conform with the following guidelines.

### High Voltage Safety Instructions

As a precaution and in case of danger, the power connector must be easily accessible. The power connector is the product's main disconnect device.

#### ⚠ CAUTION

##### Warning

All operations on this product must be carried out by sufficiently skilled personnel only.

#### ⚠ CAUTION



##### Electric Shock!

Before installing a non hot-swappable Kontron product into a system always ensure that your mains power is switched off. This also applies to the installation of piggybacks. Serious electrical shock hazards can exist during all installation, repair, and maintenance operations on this product. Therefore, always unplug the power cable and any other cables which provide external voltages before performing any work on this product.

Earth ground connection to vehicle's chassis or a central grounding point shall remain connected. The earth ground cable shall be the last cable to be disconnected or the first cable to be connected when performing installation or removal procedures on this product.

### Special Handling and Unpacking Instruction

#### NOTICE



##### ESD Sensitive Device!

Electronic boards and their components are sensitive to static electricity. Therefore, care must be taken during all handling operations and inspections of this product, in order to ensure product integrity at all times.

#### ⚠ CAUTION

Handling and operation of the product is permitted only for trained personnel within a workplace that is access controlled. Follow the "General Safety Instructions" supplied with the product.

Do not handle this product out of the product's protective enclosure while the product is not used for operational purposes unless the product is otherwise protected.

Whenever possible, unpack or pack this product only at an EOS/ESD safe workplace. Where a safe workplace is not guaranteed, it is important for the user to be electrically discharged before touching the product with his/her hands or tools. This is most easily done by touching a metal part of your system's housing.

It is particularly important to observe standard anti-static precautions when changing piggybacks, ROM devices, jumper settings etc. If the product contains batteries for RTC or memory backup, ensure that the product is not placed on conductive surfaces, including anti-static plastics or sponges. They can cause short circuits and damage the batteries or conductive circuits on the product.

## Lithium Battery Precautions

If your product is equipped with a lithium battery, take the following precautions when replacing the lithium battery.

### **⚠ CAUTION**

Risk of Explosion if the lithium Battery is replaced by an incorrect Type. Dispose of used lithium batteries according to the instructions.

Risque d'explosion si la pile au lithium est remplacée par une pile de type incorrect.  
Éliminez les piles au lithium usagées conformément aux instructions.

## General Instructions on Usage

In order to maintain Kontron's product warranty, this product must not be altered or modified in any way. Changes or modifications to the product, that are not explicitly approved by Kontron and described in this user guide or received from Kontron Support as a special handling instruction, will void your warranty.

This product should only be installed in or connected to systems that fulfill all necessary technical and specific environmental requirements. This also applies to the operational temperature range of the specific board version that must not be exceeded. If batteries are present, their temperature restrictions must be considered.

In performing all necessary installation and application operations, only follow the instructions supplied by the present user guide.

Keep all the original packaging material for future storage or warranty shipments. If it is necessary to store or ship the product then re-pack the product as delivered.

Special care is necessary when handling or unpacking the product. See Special Handling and Unpacking Instruction.

## Quality and Environmental Management

Kontron aims to deliver reliable high-end products designed and built for quality, and aims to comply with environmental laws, regulations, and other environmentally oriented requirements. For more information regarding Kontron's quality and environmental responsibilities, visit [Quality | Kontron](#) and [Material Compliance | Kontron](#).

# Table of Contents

Revision History.....	5
Symbols .....	6
For Your Safety.....	8
High Voltage Safety Instructions .....	8
Special Handling and Unpacking Instruction .....	8
Lithium Battery Precautions .....	9
General Instructions on Usage .....	9
Quality and Environmental Management .....	9
Table of Contents .....	10
List of Tables.....	12
List of Figures .....	13
1/ Introduction.....	15
2/ General Safety Instructions .....	17
2.1. Additional Safety Instructions for DC Power Supply Circuits .....	18
2.2. Instructions générales de sécurité .....	18
2.3. Electrostatic Discharge (ESD).....	19
2.4. Grounding Methods .....	20
2.5. Instructions for Lithium Battery .....	20
2.6. Thermal Conditions .....	21
3/ Shipment and Unpacking .....	22
3.1. Packaging.....	22
3.2. Unpacking.....	22
3.3. Scope of Delivery.....	22
3.4. Accessories and Spare Parts .....	23
3.5. Product Identification Type Label.....	23
4/ Product Features .....	25
4.1. Front Panel .....	25
4.1.1. Power IN Connector (X101) .....	25
4.1.2. Power Button.....	25
4.1.3. Functional Earth Bolt .....	25
4.1.4. Power LED and State LED.....	26
4.1.5. Ethernet 2.5 GbE Ports (X102, X103).....	26
4.1.6. USB 3.2 Gen 2 Ports (X104 to X107) .....	26
4.1.7. DisplayPorts (X108, X109).....	26
4.1.8. Serial Ports (X110, X111) (option) .....	26
4.1.9. Antenna (X120, X121, X122) (option) .....	27
4.1.10. System Expansion I/O Door (X201).....	28
4.1.11. Custom Front Panel Options.....	28
4.2. Rear Side.....	29
4.3. Right and Left Sides .....	29
4.4. Top Side .....	30
4.5. Bottom Side .....	31
4.6. Internal Features .....	31
4.6.1. 3.5"-SBC-RPL On-board Components .....	31
4.6.2. RTC Lithium Battery .....	33
5/ System Expansion.....	34
5.1. Before Expanding .....	34
5.2. Internal Expansion Slots .....	34
5.3. Storage Expansion .....	34
5.4. Wireless Expansion Options .....	35
5.4.1. Wi-Fi (option).....	35
5.4.2. Cellular LTE (option) .....	36
5.5. System Expansion I/O Door Options .....	37
5.5.1. Dual 2.5 GbE Ethernet .....	37
5.5.2. Dual CAN Bus .....	38

5.5.3. Dual Serial Ports (RS232) .....	38
5.5.4. Dual Serial Ports (RS232/422/485) .....	38
5.5.5. EtherCAT Port .....	39
5.5.6. 8-Channel GPIO/DIO .....	39
5.5.7. Cellular LTE SIM Slot .....	41
5.6. Custom Front Panel .....	42
5.6.1. Dual Ethernet and Dual DisplayPorts.....	42
6/ Thermal and Power Management.....	43
6.1. Passive Cooling .....	43
6.2. Heatsink.....	43
6.3. Mount Orientation .....	43
6.4. Minimum Clearance .....	43
6.5. Maximum Processor Power and Temperatures.....	44
6.6. Power Consumption and Thermal Monitoring.....	44
6.7. Configuring the Processor TDP.....	45
6.8. Third Party Components.....	45
7/ Assembly .....	46
8/ Installation.....	47
8.1. Before Installing .....	47
8.2. DIN Rail Clamp (rear side).....	47
8.3. DIN Rail Clamp (bottom side) .....	48
8.4. Rugged DIN Rail Clamp (rear side).....	49
8.5. Book Mount Bracket.....	49
8.6. Clearance.....	50
9/ Starting UP.....	52
9.1. Before Starting .....	52
9.2. Connecting to an External 24 VDC Power Supply.....	53
9.2.1. Wiring the Power IN Connector.....	53
9.3. Connecting to the AC/DC Power Supply.....	54
9.4. Switching On/Off.....	54
9.5. Operating System (OS) and Drivers .....	55
10/ Mobile Network .....	56
10.1. Before Setting Up .....	56
10.2. Setting up the Mobile Network.....	56
10.3. Inserting a SIM Card .....	56
11/ Product Specification .....	57
11.1. Block Diagram.....	57
11.2. Hardware Specification .....	58
11.3. Software Specification.....	59
11.4. Power Specification .....	59
11.4.1. Power Supply Protection Requirements.....	60
11.4.2. Power Consumption .....	60
11.4.3. Functional Earth.....	60
11.5. Environmental Specification.....	61
11.6. Mechanical Specification.....	62
11.7. Compliance.....	63
12/ Connectors and LEDs.....	65
12.1. Front Panel Connector Pin Assignments .....	65
12.1.1. Power IN Connector (X101) .....	65
12.1.2. Ethernet 2.5 GbE Port (X102, X103) .....	65
12.1.3. USB 3.2 Gen 2 Port (X104 to X107).....	66
12.1.4. DisplayPort (X108, X109) .....	67
12.1.5. Serial Port RS232 (X110, X111) .....	67
12.1.6. Antenna (X120, X121, X122).....	68
12.2. System Expansion I/O Door Pin Assignments Options (X201).....	69
12.2.1. CAN Bus Port.....	69
12.2.2. 2.5 GbE Port.....	69

12.2.3. Serial Port (RS232) .....	70
12.2.4. Serial Port (RS232/422/485 configurable).....	70
12.2.5. EtherCAT Port .....	71
12.2.6. 8-Channel GPIO/DIO Connector .....	71
12.2.7. SIM Slot.....	72
12.3. On-board Header Pin Assignments .....	72
12.3.1. RTC Lithium Battery Power Input Header.....	72
13/ BIOS .....	73
13.1. Starting the uEFI BIOS.....	73
13.2. BIOS Update .....	74
13.3. Setup Menus .....	74
13.4. Main Setup Menu .....	75
13.5. Advanced Setup Menu .....	77
13.6. ChipSet Setup Menu.....	86
13.7. Security Setup Menu .....	97
13.8. Boot Setup Menu .....	99
13.9. Save and Exit Setup Menu.....	100
14/ Maintenance and Prevention.....	101
14.1. Cleaning.....	102
14.2. Replacing the RTC Lithium Battery .....	102
14.3. Inserting and Extracting a SIM Card .....	104
15/ Technical Support.....	106
15.1. Returning Defective Merchandise.....	106
16/ Storage and Transportation .....	107
16.1. Storage .....	107
16.2. Transportation.....	107
17/ Warranty .....	108
17.1. Limitation/Exemption from Warranty Obligation .....	108
18/ Disposal .....	109
18.1. Disposal .....	109
18.2. WEEE Compliance.....	109
18.3. Data Sanitization .....	109
18.4. Statement of Memory Volatility.....	111
19/ Cyber Security .....	113
19.1. Security Defense Strategy .....	113
Appendix: List of Acronyms.....	114

## List of Tables

Table 1: Scope of Delivery .....	22
Table 2: Accessories and Spare Parts .....	23
Table 3: Product Identification.....	23
Table 4: Power LED and State LED Description .....	26
Table 5: Storage SSD Module Specification.....	34
Table 6: Wi-Fi Module Specification.....	35
Table 7: Cellular LTE Module Specification .....	36
Table 8: System Expansion I/O Door Combination Overview .....	37
Table 9: Dual 2.5 GbE Ethernet Module.....	37
Table 10: Dual CAN Module .....	38
Table 11: Dual Serial Ports RS232 Module .....	38
Table 12: Dual Serial Ports RS232/422/485 Module .....	38
Table 13: RS Mode Configuration .....	39
Table 14: EtherCAT Module .....	39

Table 15: GPIO Input Channels Specification .....	40
Table 16: GPIO Output Channels Specification .....	40
Table 17: Processor TDP and Maximum Temperature Values.....	44
Table 18: Power Consumption .....	45
Table 19: Hardware Specification .....	58
Table 20: Software Specification .....	59
Table 21: Electrical Specification 24 VDC .....	60
Table 22: Environmental Specification.....	61
Table 23: Mechanical Specification.....	62
Table 24: Compliance CE Mark.....	63
Table 25: Compliance RED mark .....	63
Table 26: International Compliance.....	64
Table 27: Power IN Connector Pin Assignment (X101) .....	65
Table 28: Ethernet 2.5 GbE Port Pin Assignment (X102, X103).....	65
Table 29: USB Type A Port Pin Assignment (X104-X107) .....	66
Table 30: DisplayPort Pin Assignment (X108, X109) .....	67
Table 31: Serial Port (RS232) Pin Assignment (X110, X111).....	67
Table 32: Antenna Type .....	68
Table 33: CAN Bus Port Pin Assignment.....	69
Table 34: 2.5 GbE Ethernet Port Pin Assignment.....	69
Table 35: Serial Port (RS232) Pin Assignment .....	70
Table 36: Serial Port (RS232/422/485) Pin Assignment .....	70
Table 37: EtherCAT Port Pin Assignment .....	71
Table 38: GPIO/DIO Connector Pin Assignment.....	71
Table 39: RTC Power Input Header Pin Assignment.....	72
Table 40: Navigation Hot Keys .....	73
Table 41: Advanced Setup Menu Sub-screens Example .....	78
Table 42: Chipset Setup Menu Sub-screens Example .....	86
Table 43: Security Setup Menu Sub-screens Example .....	97
Table 44: Boot Setup Menu Sub-screens Example.....	99
Table 45: Save and Exit Setup Menu Sub-screens Example .....	100
Table 46: KBox A-151-RPL Statement of Memory Volatility Example.....	111

## List of Figures

Figure 1: KBox A-151-RPL .....	15
Figure 2: Type Label Example .....	24
Figure 3: Front Panel .....	25
Figure 4: Wi-Fi and Cellular LTE Connectors and Antenna Types.....	27
Figure 5: Rear Side.....	29
Figure 6: Right and Left Sides .....	29
Figure 7: Top Side.....	30
Figure 8: Bottom Side.....	31
Figure 9: 3.5"-SBC-RPL On-board Components- Top Side.....	32
Figure 10: 3.5"-SBC-RPL On-board Components- Bottom Side.....	33
Figure 11: Input Application Connected to GPIO .....	40
Figure 12: Output Application Connected to GPIO .....	40
Figure 13: Custom Front Panel with Dual Ethernet and Dual DP Ports.....	42
Figure 14: DIN Rail Clamp (50 mm x 50 mm) .....	47
Figure 15: DIN Rail Clamp (50 mm x 100 mm) .....	48

Figure 16: Rugged DIN Rail Clamp .....	49
Figure 17: Book Mount Bracket .....	50
Figure 18: Keep Out Areas- Vertical .....	51
Figure 19: Power IN Connector and Mating Power IN Connector .....	53
Figure 20: Block Diagram KBox A-151-RPL .....	57
Figure 21: Mechanical Dimensions (mm).....	62
Figure 22: Main Setup Menu Example .....	75
Figure 23: Advanced Setup Menu Example .....	77
Figure 24: Chipset Setup Menu Example .....	86
Figure 25: Security Setup Menu Example .....	97
Figure 26: Boot Setup Menu Example.....	99
Figure 27: Save and Exit Setup Menu Example .....	100
Figure 28: RTC Lithium Battery (default) and Automotive Lithium Battery Module (option).....	103

# 1/Introduction

This user guide describes the KBox A-151-RPL designed for DIN Rail applications and also known as product within this user guide. This user guide focuses on describing the product's special features and how to assemble, install, operate, maintain and dispose of the product properly. New users are recommended to study the instructions within this user guide before switching on the product.

The KBox A-151-RPL is a flexible fanless industrial grade DIN Rail box PC designed for use in performance demanding applications requiring flexible DIN Rail mounting in limited space, 24/7 continuous operation and longtime industrial employment. Based on Kontron's 3.5" Single Board Computer (SBC) using 13<sup>th</sup> Gen Intel® Core™ U series of processors, the KBox A-151-RPL features a variety of external interfaces to enable extensive connectivity and allows for additional storage and wireless features such as Wi-Fi and/or cellular LTE. System expansion increases via the use of a system expansion I/O door on the front panel supporting a wide variety of interface options. All components are selected to ensure a long lifetime and the fanless design ensures a significantly prolonged lifespan and high system availability.

**Figure 1: KBox A-151-RPL**



The main features are:

Processor:

- › 13<sup>th</sup> Gen Intel® Core™ U series

System memory:

- › Up to 64 GByte with DDR5 SODIMM

Storage:

- › Up to 2 TByte with M.2 NVMe SSD

Front connectors:

- › 2x DP++
- › 4x USB 3.2 Gen 2
- › 2x 2.5 GbE
- › 2x Serial Ports RS232

Wireless connectivity options:

- › Wi-Fi
- › LTE

#### System expansion options on the front panel:

- › System expansion I/O door options:
  - › Dual CAN
  - › Dual GbE
  - › Dual Serial Ports RS232
  - › Dual Serial Ports RS232/422/485 (configurable)
  - › EtherCAT
  - › 8-Channel GPIO/Digital IO
- › Custom front panel options:
  - › Dual Ethernet + Dual DP with custom front panel

#### Chassis

- › Metal chassis with heatsink
- › Fanless passive cooling

#### Power

- › Power IN 24 VDC, range: 10 VDC to 34 VDC (abs. max. 36 VDC)
- › 80 W



To ensure you have the latest version of this user guide, visit [Kontron's Embedded Box PC, KBox A-151-RPL website.](#)

---

## 2/General Safety Instructions

Please read this passage carefully and take careful note of the instructions, which have been compiled for your safety and to ensure to apply in accordance with intended regulations. If the following general safety instructions are not observed, it could lead to injuries to the operator and/or damage of the product; in cases of non-observance of the instructions Kontron Europe is exempt from accident liability, this also applies during the warranty period.

The product has been built and tested according to the basic safety requirements for low voltage (LVD) applications and has left the manufacturer in safety-related, flawless condition. To maintain this condition and to also ensure safe operation, the operator must not only observe the correct operating conditions for the product but also the following general safety instructions:

- The product must be used as specified in the product documentation, in which the instructions for safety for the product and for the operator are described. These contain guidelines for setting up, installation and assembly, maintenance, transport or storage.
- The on-site electrical installation must meet the requirements of the country's specific local regulations.
- If a power cable comes with the product, only this cable should be used. Do not use an extension cable to connect the product.
- To guarantee that sufficient air circulation is available to cool the product, please ensure that the ventilation openings are not covered or blocked. If a filter mat is provided, this should be cleaned regularly. Do not place the product close to heat sources or damp places. Make sure the product is well ventilated.
- Only connect the product to an external power supply providing the voltage type (AC or DC) and the input power (max. current) specified on the Kontron Product Label and meeting the requirements of the Limited Power Source (LPS) and Power Source (PS2) of UL/IEC 62368-1 .
- Only products or parts that meet the requirements for Power Source (PS1) of UL/IEC 62368-1 may be connected to the product's available interfaces (I/O).
- Before opening the product, make sure that the product is disconnected from the mains.
- Switching off the product by its power button does not disconnect it from the mains. Complete disconnection is only possible if the power cable is removed from the wall plug or from the product. Ensure that there is free and easy access to enable disconnection.
- The product may only be opened for the insertion or removal of add-on cards (depending on the configuration of the product). This may only be carried out by qualified operators.
- If extensions are being carried out, the following must be observed:
  - all effective legal regulations and all technical data are adhered to
  - the power consumption of any add-on card does not exceed the specified limitations
  - the current consumption of the product does not exceed the value stated on the product label
- Only original accessories that have been approved by Kontron Europe can be used.
- Please note: safe operation is no longer possible when any of the following applies:
  - the product has visible damages or
  - the product is no longer functioning
 In this case the product must be switched off and it must be ensured that the product can no longer be operated.
- Handling and operation of the product is permitted only for trained personnel within a work place that is access controlled.
- CAUTION: Risk of explosion if the lithium battery is replaced incorrectly (short-circuited, reverse-poled, wrong lithium battery type). Dispose of used lithium batteries according to the manufacturer's instructions.
- This product is not suitable for use in locations where children are likely to be present

## 2.1. Additional Safety Instructions for DC Power Supply Circuits

- › To guarantee safe operation, please observe that:
  - › the external DC power supply must meet the criteria for LPS and PS2 (UL/IEC 62368-1)
  - › no cables or parts without insulation in electrical circuits with dangerous voltage or power should be touched directly or indirectly
  - › a reliable functional earth connection is provided
  - › a suitable, easily accessible disconnecting device is used in the application (e.g. overcurrent protective device), if the product itself is not disconnect able
  - › a disconnect device, if provided in or as part of the product, shall disconnect both poles simultaneously
  - › interconnecting power circuits of different products cause no electrical hazards
- › A sufficient dimensioning of the power cable wires must be selected – according to the maximum electrical specifications on the product label – as stipulated by EN62368-1 or VDE0100 or EN60204 or UL61010-1 regulations.

For the General Safety Instruction in German or French, visit Kontron's product web page> Downloads> Manuals> General Safety Instructions.

## 2.2. Instructions générales de sécurité

Veillez lire attentivement ce passage et prendre bonne note des instructions, qui ont été compilées pour votre sécurité et pour assurer une application conforme aux réglementations prévues. Le non-respect des consignes de sécurité générales suivantes peut entraîner des blessures pour l'utilisateur et/ou des dommages pour le produit. En cas de non-respect des consignes, Kontron Europe est exonéré de la responsabilité en cas d'accident, ceci s'applique également pendant la période de garantie.

Le produit a été construit et testé conformément aux exigences de sécurité de base pour les applications basse tension (DBT) et a quitté le fabricant dans un état impeccable en matière de sécurité. Pour maintenir cet état et pour garantir également un fonctionnement sûr, l'opérateur doit non seulement respecter les conditions d'utilisation correctes du produit, mais aussi les consignes de sécurité générales suivantes :

- › Le produit doit être utilisé conformément à la documentation du produit, dans laquelle sont décrites les instructions de sécurité pour le produit et pour l'opérateur. Celles-ci contiennent des directives pour la mise en place, l'installation et le montage, la maintenance, le transport ou le stockage.
- › L'installation électrique sur place doit répondre aux exigences des réglementations locales spécifiques du pays.
- › Si un câble d'alimentation est fourni avec le produit, seul ce câble doit être utilisé. N'utilisez pas de rallonge pour connecter le produit.
- › Afin de garantir une circulation d'air suffisante pour refroidir le produit, veuillez vous assurer que les ouvertures de ventilation ne sont pas couvertes ou obstruées. Si un élément filtrant est fourni, celui-ci doit être nettoyé régulièrement. Ne placez pas le produit à proximité de sources de chaleur ou d'endroits humides. Veillez à ce que le produit soit bien ventilé.
- › Ne connectez le produit qu'à une alimentation externe fournissant le type de tension (AC ou DC) et la puissance d'entrée (courant max.) spécifiés sur le Label Produit Kontron et répondant aux exigences de la source d'alimentation limitée (LPS) et de la source d'alimentation (PS2) de la norme UL/IEC 62368-1 .
- › Seuls les produits ou les pièces qui répondent aux exigences de la source d'alimentation (PS1) de la norme UL/IEC 62368-1 peuvent être connectés aux interfaces (E/S) disponibles du produit.
- › Avant d'ouvrir le produit, assurez-vous qu'il est bien débranché du secteur.
- › Le fait d'éteindre le produit par son bouton de mise en marche ne le déconnecte pas du secteur. Une déconnexion complète n'est possible que si le câble d'alimentation est retiré de la prise murale ou du produit. Veillez à ce que l'accès soit libre et facile pour permettre la déconnexion.
- › Le produit ne peut être ouvert que pour l'insertion ou le retrait de cartes supplémentaires (selon la configuration du produit). Cette opération ne peut être effectuée que par des opérateurs qualifiés.

- › Si des extensions sont effectuées, les points suivants doivent être respectés :
  - › toutes les réglementations légales en vigueur et toutes les données techniques sont respectées
  - › la consommation électrique d'une carte supplémentaire ne dépasse pas les limites spécifiées
  - › la consommation actuelle du produit ne dépasse pas la valeur indiquée sur l'étiquette du produit.
- › Seuls les accessoires d'origine approuvés par Kontron Europe peuvent être utilisés.
- › Veuillez noter que la sécurité des opérations n'est plus possible lorsque l'une des conditions suivantes s'applique.
  - › le produit présente des dommages visibles ou
  - › le produit ne fonctionne plus. Dans ce cas, le produit doit être éteint et il faut s'assurer que le produit ne puisse plus être utilisé.
- › La manipulation et le fonctionnement du produit ne sont autorisés que pour le personnel formé dans un lieu de travail dont l'accès est contrôlé.
- › ATTENTION: Risque d'explosion en cas de remplacement incorrect de la pile au lithium (court-circuit, inversion de polarité, mauvais type de pile au lithium). Éliminez les piles au lithium usagées conformément aux instructions du fabricant.
- › Ce produit n'est pas adapté à une utilisation dans des endroits où des enfants sont susceptibles d'être présents
- › Instructions de sécurité supplémentaires pour les circuits d'alimentation en courant continu
- › Pour garantir un fonctionnement sûr, veuillez observer ce qui suit:
  - › l'alimentation électrique externe en courant continu doit répondre aux critères des LPS et PS2 (UL/IEC 62368-1)
  - › aucun câble ou pièce non isolée dans les circuits électriques ayant une tension ou une puissance dangereuse ne doit être touché directement ou indirectement
  - › une connexion à la terre fonctionnelle fiable est fournie
  - › un dispositif de déconnexion approprié et facilement accessible est utilisé dans l'application (par exemple, un dispositif de protection contre les surintensités), si le produit lui-même n'est pas en mesure d'être déconnecté.
  - › un dispositif de déconnexion, s'il est prévu dans le produit ou s'il en fait partie, doit déconnecter les deux pôles simultanément
  - › l'interconnexion des circuits électriques de différents produits ne présente aucun risque électrique
- › Un dimensionnement suffisant des fils du câble d'alimentation doit être choisi - en fonction des spécifications électriques maximales figurant sur l'étiquette du produit - comme stipulé par les réglementations EN62368-1 ou VDE0100 ou EN60204 ou UL61010-1.

### 2.3. Electrostatic Discharge (ESD)



#### **ESD Sensitive Device!**

Keep electrostatic sensitive parts in their containers until they arrive at the ESD-safe workplace. Always be properly grounded when touching a sensitive board, component, or assembly.

A sudden discharge of electrostatic electricity can destroy static-sensitive devices or micro-circuitry. Proper packaging and grounding techniques are necessary to prevent damage. Always take the following precautions:

1. Transport boards in ESD-safe containers such as boxes or bags.
2. Keep electrostatic sensitive parts in their containers until they arrive at the ESD-safe workplace.
3. Always be properly grounded when touching a sensitive board, component, or assembly.
4. Store electrostatic-sensitive boards in protective packaging or on antistatic mats.

## 2.4. Grounding Methods

The following measures help to avoid electrostatic damage to the product:

1. Cover workstations with approved antistatic material. Always wear a wrist strap connected to the workplace, as well as properly grounded tools and equipment.
2. Use antistatic mats, heel straps, or air ionizers for more protection.
3. Always handle electrostatically sensitive components by their edge or by their casing.
4. Avoid contact with pins, leads, or circuitry.
5. Switch off power and input signals before inserting and removing connectors or connecting test equipment.
6. Keep the work area free of non-conductive materials such as ordinary plastic assembly aids and styrofoam.
7. Use field service tools such as cutters, screwdrivers, and vacuum cleaners that are conductive.
8. Always place drives and boards with the PCB-assembly-side down on the foam.

## 2.5. Instructions for Lithium Battery

The product is equipped with a Kontron specified RTC lithium battery. The RTC lithium battery may over time need to be replaced. Note that there is a risk of explosion if the lithium battery is replaced incorrectly (short-circuited, reverse-poled, wrong lithium battery type).

Replace the RTC lithium battery, only with the same type of lithium battery or with a Kontron recommended RTC lithium battery type, see Table 2: Accessories and Spare Parts.

For instructions on how to replace the RTC Lithium battery, see Chapter 14/ Maintenance and Prevention. After removing the lithium battery, dispose of the lithium battery according to the regulations within your region.

### ⚠ CAUTION

#### **Danger of Explosion if the lithium battery is incorrectly placed!**

- Replace only with the same or equivalent type recommended by the manufacturer
- Dispose of used batteries according to the manufacturer's instructions

#### **ATTENTION- Risque d'explosion avec l'échange inadéquat de la batterie!**

- Remplacement seulement par le même ou un type équivalent recommandé par le producteur
- L'évacuation des batteries usagées conformément à des indications du fabricant

#### **VORSICHT- Explosionsgefahr bei unsachgemäßem Austausch der Batterie!**

- Ersatz nur durch denselben oder einen vom Hersteller empfohlenen gleichwertigen Typ
- Entsorgung gebrauchter Batterien nach Angaben des Herstellers



Do not dispose of lithium batteries in general trash collection. Dispose of the lithium battery according to the local regulations dealing with the disposal of these special materials, (e.g. to the collecting points for disposal of batteries).

## 2.6. Thermal Conditions

The product is passively cooled using a heatsink. There is a risk of burns or injury when touching the heatsink.

---

### Hot Surface

Heatsinks can get very hot. To avoid burns and personal injury when handling the heatsink:

- › Do not touch while in operation
- › Allow to cool before handling
- › Wear protective gloves

### Surface chaude

Le dissipateur thermique peut devenir très chaud. Pour éviter les brûlures et les blessures lors de la manipulation du dissipateur thermique :

- › Ne pas toucher pendant le fonctionnement
- › Laisser refroidir avant la manipulation
- › Portez des gants de protection

### Heiße Oberfläche

Der Kühlkörper kann sehr heiß werden. Um Verbrennungen und Verletzungen beim Umgang mit dem Kühlkörper zu vermeiden:

- › Während des Betriebs nicht berühren
  - › Vor der Handhabung abkühlen lassen
  - › Schutzhandschuhe tragen
- 



## 3/ Shipment and Unpacking

### 3.1. Packaging

The KBox A-151-RPL is packaged together with all parts, in a product specific cardboard package designed to provide adequate protection and absorb shock.

### 3.2. Unpacking

To unpack the product, perform the following:

1. Remove packaging.
2. Do not discard the original packaging. Keep the original packaging for future transportation or storage.
3. Check the delivery for completeness by comparing the delivery with the original order.
4. Keep the associated paperwork. It contains important information for handling the product.
5. Check the product for visible shipping damage.

If you notice shipping damage or inconsistencies between the contents and the original order, contact your dealer.

### 3.3. Scope of Delivery

The scope of delivery describes the parts included in your delivery. Check that the delivery is complete and contains the items listed. If damaged or missing items are discovered, contact your dealer.

**Table 1: Scope of Delivery**

Product	Description
KBox A-151-RPL	KBox A-151-RPL with customer defined hardware configuration of processor and system expansion options.
Power Connector	Default <ul style="list-style-type: none"> <li>➤ 3-pin Phoenix power connector (PSC 1.5/ 3-F) (to be wired and connected to a user provided external power supply)</li> </ul> Option <ul style="list-style-type: none"> <li>➤ 24 VDC AC/DC Power Supply (80 W) with 3-pin Phoenix power connector (PSC 1.5/ 3-F) and power cable with plug for your region</li> </ul>
DIN Rail clamp	The factory mounted DIN Rail clamp options are: <ul style="list-style-type: none"> <li>➤ DIN Rail clamp 50 mm x 50 mm (rear side) or</li> <li>➤ Rugged DIN Rail clamp (rear side) or</li> <li>➤ DIN Rail clamp 50 mm x 100 mm (bottom side) or</li> <li>➤ Book Mount Bracket 60 mm x 216 mm (rear or bottom sides)</li> </ul>
Antenna	Wi-Fi and LTE antenna Only included in the delivery if hardware configured with Wi-Fi and/or cellular LTE.
General Safety Instructions	General Safety Instructions document

### 3.4. Accessories and Spare Parts

**Table 2: Accessories and Spare Parts**

Part Number	Part	Description
EE04-100001-01	3-pin Phoenix Power Connector	3-pin Phoenix power connector (PSC 1.5/3-F) incl. housing
ER40-100012-01	24 VDC External AC/DC Power supply (80 w)	24 VDC External AC/DC Power supply (80 W), cable 1.4 m with 3-pin Phoenix power connector (PSC 1.5/ 3-F)
840-0059	Power cable EU	Power cable AC mains (2 m) to external Europe plug
840-0115	Power cable UK	Power cable AC mains (1.8 m) to external UK plug
0-0064-4317	Power cable US	Power cable AC mains (2 m) to external USA plug
1068-4995	BR2032 3V Lithium battery	BR2032 3V Lithium battery with cable
9-5000-1151	KIT Bookmount	Book mount adapter plate incl. Screws
9-5000-1154	KIT Rugged DIN-RAIL	Rugged DIN-RAIL adapter incl. screws
9-5000-1155	KIT DIN-RAIL	DIN-RAIL adapter incl. Screws
Manufacturer: SparkLan Article Number: R3410A10050 Product Name: AD-501AX	Wi-Fi Antenna 	Connector: RP-SMA (male) Type: Wi-Fi 6E Dipole Antenna Frequency: 2.4/5/6 GHz Peak gain: 3.7 dBi/5 dBi/5 dBi L x W x T: 162 x 22 x 6.8 mm Articulated hinge: 0° to 90° Impedance: 50 ohms
Manufacturer: 2J Antennas Article Number: 2JW0924-C952B	LTE Antenna 	Connector: SMA (male) Type: 4G LTE Pattern: Omni - directional Frequency: 698-960/1710-2170/2500-2700 MHz Peak Gain: 0.6 / 2.6 / 2.3 dBi (approx.) L x W x T: 170 x 18 x 10 mm Articulated hinge: 0° to 90° Impedance: 50 ohms

### 3.5. Product Identification Type Label

The KBox A-151-RPL is part of Kontron's A-Series DIN Rail embedded Box PCs intended for control cabinet applications.

**Table 3: Product Identification**

System Type	Product Designation	Model	Description
KBox A	KBox A-151	KBox A-151-RPL	Corresponds to hardware configurations based on the Kontron 3.5"-SBC-RPL Single Board Computer with Intel® Core™ U 13th Gen series of processors.

The type label is used for product identification and includes important product specific Information such as the electrical specification and the compliance of the ordered product variant.

**Figure 2: Type Label Example**

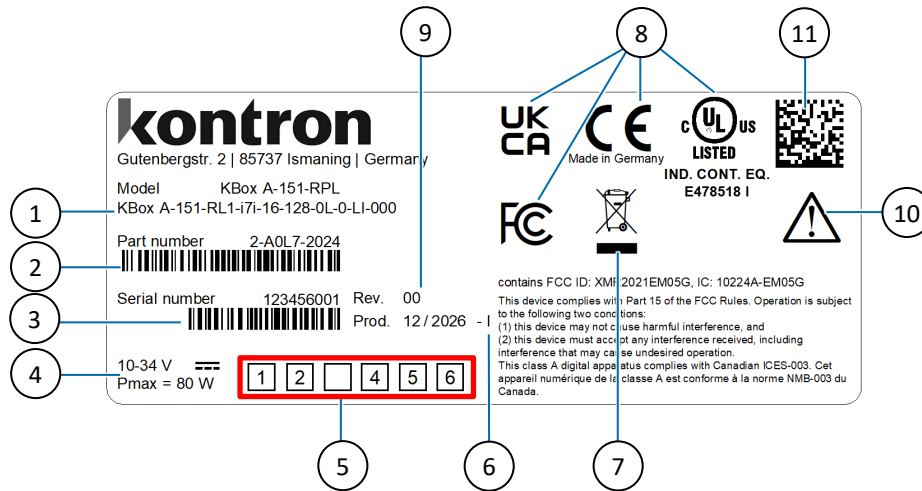

- |   |                            |    |                      |
|---|----------------------------|----|----------------------|
| 1 | Model/Product family       | 6  | Production date      |
| 2 | Part Number with bar code  | 7  | Dispose of correctly |
| 3 | Serial Number and bar code | 8  | Compliance           |
| 4 | Electrical specification   | 9  | Revision             |
| 5 | For Internal use           | 10 | Observe warnings     |
|   |                            | 11 | QR Code              |

## 4/Product Features

### 4.1. Front Panel

The front panel features all the I/O interfaces, status LEDs and the power connection.

**Figure 3: Front Panel**

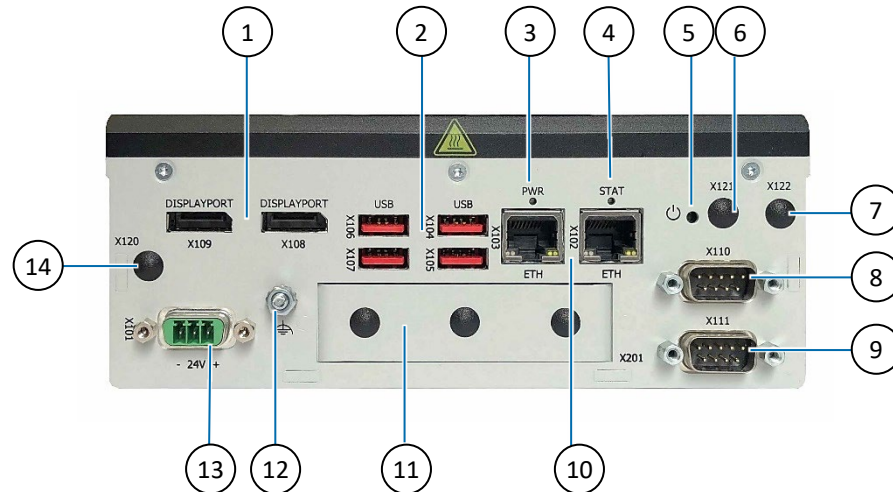

- |   |                              |    |                                     |
|---|------------------------------|----|-------------------------------------|
| 1 | 2x DisplayPort (X109, X108)  | 8  | 1x Serial port (X110) (option)      |
| 2 | 4x USB 3.2 Gen 2 (X107-X104) | 9  | 1x Serial port (X111) (option)      |
| 3 | 1x Power LED                 | 10 | 2x 2.5 GbE Ethernet (X103, X102)    |
| 4 | 1x State LED                 | 11 | 1x System expansion I/O door (X201) |
| 5 | 1x Power button              | 12 | 1x Functional earth bolt            |
| 6 | 1x Antenna (X121)            | 13 | 1x Power IN connector (X101)        |
| 7 | 1x Antenna (X122)            | 14 | 1x Antenna (X120)                   |

#### 4.1.1. Power IN Connector (X101)

The 3-pin Power IN connector (PSC 1.5/ 3-M) connects to an appropriate DC power supply using the mating Power IN connector (PSC 1.5/ 3-F) included in the delivery. The Power IN connector includes reverse polarity protection to prevent damage in the event that the DC supply is connected with incorrect polarity.

To wire the mating Power IN connector, see Chapter 9.2.1: Wiring the Power IN Connector.

For the pin assignment of the Power IN connector, see Chapter 12.1.1: Power IN Connector (X101).

#### 4.1.2. Power Button

The power button switches on or switches off the product. Pressing the power button for more than four seconds switches the product from the 'on' to 'off' state.

#### 4.1.3. Functional Earth Bolt

The functional earth bolt connects to the chassis ground.

#### 4.1.4. Power LED and State LED

The STAT LED indicates the product's power status and the PWR LED indicates the product's power-good status.

**Table 4: Power LED and State LED Description**

STAT LED (green)	PWR LED (yellow)	Description
On	On	Power on (Fully operational)
Flashing	On	Suspend-To-RAM
Off	On	Suspend-To-Disk or Soft Off
Off	Off	Power off

#### 4.1.5. Ethernet 2.5 GbE Ports (X102, X103)

The Ethernet LAN ports (X102, X103) each support one channel of 10/100/1000/2500 Mbit Ethernet.



To achieve the specified Ethernet port performance, Category 5 twisted pair cables must be used with 10/100 Mbit and Category 5E, 6 or 6E with 1 GbE/2.5 GbE Ethernet networks.



Only connect the product to internal Ethernet network without exiting a facility and being subjected to TNVs.

For the pin assignment of the Ethernet ports and information regarding the Ethernet status LEDs, see Chapter 12.1.2: Ethernet 2.5 GbE Port (X102, X103).

#### 4.1.6. USB 3.2 Gen 2 Ports (X104 to X107)

The four USB ports (X104, X105, X106 and X107) support USB 3.2 Gen 2 compatible devices using a USB Type A connector.



The USB 3.2 Gen 2 ports are backwards compatible with USB 3.2 Gen 1 (or later thereof) and USB 2.0 ports.

For the pin assignment of the USB 3.2 Gen 2 ports, see Chapter 12.1.3: USB 3.2 Gen 2 Port (X104 to X107).

#### 4.1.7. DisplayPorts (X108, X109)

The two DisplayPorts (DP) (X108, X109) are standard DP++ ports with a maximum resolution of 7680 x 4230 at 60 Hz. The product supports up to four displays. To implement an additional display, use a suitable system expansion I/O module.



DisplayPort ++ supports the use of passive adapters to connect to HDMI or DVI.

For the pin assignment of the DP connector, see Chapter 12.1.4: DisplayPort (X108, X109).

#### 4.1.8. Serial Ports (X110, X111) (option)

The breakouts (X110, X111) support up to two serial RS232 connections.

For the pin assignment of the serial ports, see Chapter 12.1.5: Serial Port RS232 (X110, X111).

#### 4.1.9. Antenna (X120, X121, X122) (option)

The three antennas (X120, X121, X122) support Wi-Fi and/or LTE depending on the internal hardware configuration. If Wi-Fi and/or cellular LTE are not implemented the openings for (X120, X121, X122) are covered.

Wi-Fi and cellular LTE use different antenna types that are not electrically compatible and not interchangeable. Before connecting to an antenna connector, refer to Figure 4. Users are responsible for connecting the correct antenna type to the product's antenna connectors.

The position of the antenna may affect performance. Do not place the antenna close to a noise source that may cause interference. Additional antennas may be implemented on the system expansion I/O door if the system expansion I/O door is not implemented with another feature.

##### Antenna RF exposure

To avoid RF antenna exposure:

##### CAUTION

- Avoid placing the antenna near people, minimum distance 20 cm.
- Avoid pointing the antenna at people.
- Keep a safe distance from the antenna especially when transmitting.

##### NOTICE

##### RP-SMA and SMA Antenna are not Interchangeable!

RP-SMA and SMA connectors and antenna are not electrically compatible. Incorrect connection may result in an insufficient connection or destroy the center pin.



Kontron recommends the use of Kontron's reference antenna included in the delivery and chosen to meet RF performance requirements, and to support a nominal impedance of 50 ohms, see Table 2: Accessories and Spare Parts.

Figure 4: Wi-Fi and Cellular LTE Connectors and Antenna Types

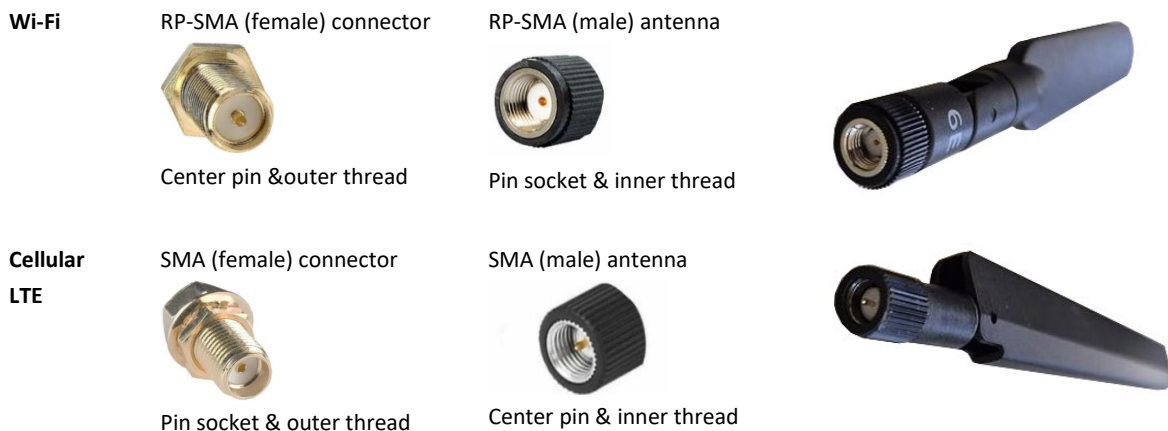

For more information regarding the delivered antenna and the antenna requirements, see Chapter 12.1.6: Antenna (X120, X121, X122) and Table 2: Accessories and Spare Parts.

#### **4.1.10. System Expansion I/O Door (X201)**

The system expansion I/O door (X201) supports one factory installed I/O expansion option or a SIM Card slot for cellular LTE.

For information on the system expansion I/O door options, see Chapter 5.5: System Expansion I/O Door Options.

#### **4.1.11. Custom Front Panel Options**

A custom front panel is available that implements the Kontron 3.5" extended I/O board with dual DP and dual 2.5 GbE and supporting only one serial port and two antenna connectors. The system expansion I/O door options are not available.

For information on the custom front panel option, see Chapter 5.6: Custom Front Panel.

## 4.2. Rear Side

The rear side features two-threaded openings used for the factory installed DIN Rail clamp, rugged DIN Rail clamp or book mount bracket.

Figure 5: Rear Side

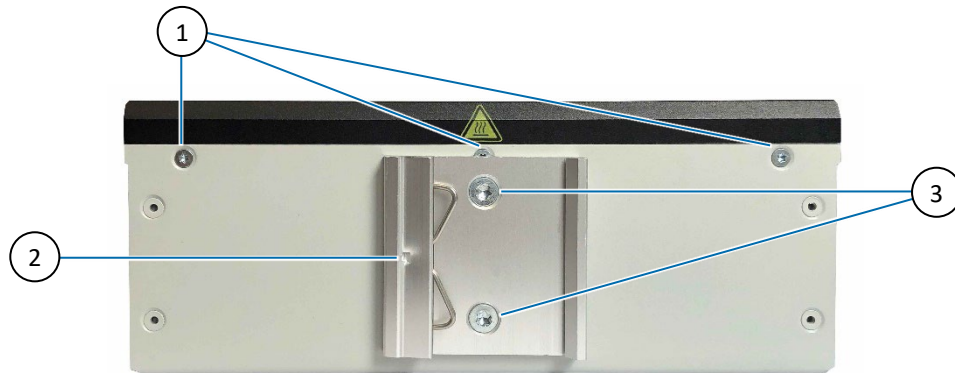

- |  |  |
|--|--|
| <p>1 3x Screws securing the heatsink-front-panel assembly.</p> | <p>2 DIN Rail clamp (50 mm x 50 mm)</p> <p>3 2x threaded screw openings for DIN Rail clamp or book mount bracket</p> |
|--|--|



The rear and bottom side DIN Rail clamps are not interchangeable due to a difference in size.

## 4.3. Right and Left Sides

The right and left sides feature no operational parts.

Figure 6: Right and Left Sides



- |  |                                 |
|--|---------------------------------|
| <p>1 1x Screw securing the heatsink-front-panel assembly</p> | <p>2 Type label (left side)</p> |
|--|---------------------------------|

#### 4.4. Top Side

The top side features a heatsink.

Figure 7: Top Side



##### Hot Surface

Heatsinks can get very hot. To avoid burns and personal injury when handling the heatsink:

- › Do not touch while in operation
  - › Allow to cool before handling
  - › Wear protective gloves
-

## 4.5. Bottom Side

The bottom side features two-threaded openings used to mount a DIN Rail clamp (50 mm x 100 mm) or book mount bracket.

**Figure 8: Bottom Side**

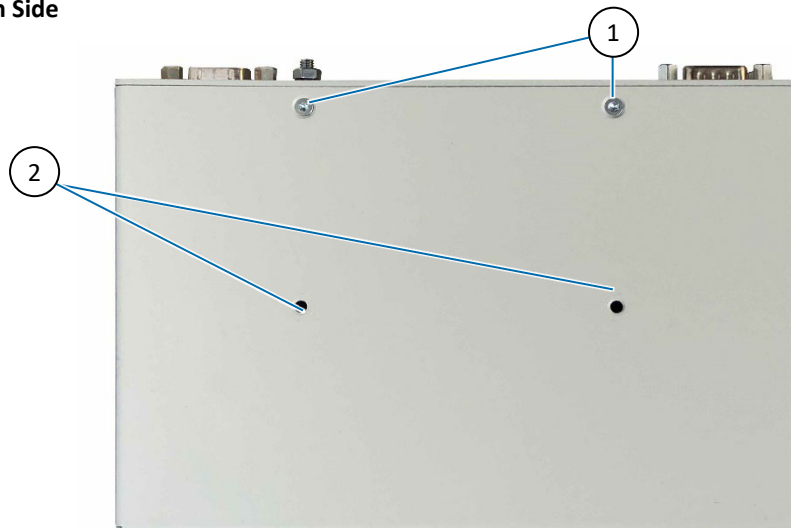

- |  |  |
|--|--|
| <p>1 2x Screws securing the heatsink-front-panel assembly.</p> | <p>2 2x threaded screw openings for DIN Rail clamp (50 mm x 100 mm) or book mount brackets</p> |
|--|--|



The rear and bottom side DIN Rail clamps are not interchangeable due to a difference in size.

## 4.6. Internal Features

Opening the product may damage internal components and invalidate the warranty. To replace or install internal components, return the product to Kontron. For more information, refer to Chapter 15.1: Returning Defective Merchandise.

### Protection Label

#### **NOTICE**

The product is factory configured to meet customer requirements and then sealed with a protection label. Opening the product invalidates the warranty and may cause damage to internal components.

### 4.6.1. 3.5"-SBC-RPL On-board Components

The following chapter provides 3.5"-SBC-RPL board layout and connector, header and jumper information.

### Handle with Care

#### **NOTICE**

The internal 3.5"-SBC-RPL board contains components on both sides that damage easily if handled without reasonable care, resulting in malfunction or no function at all.

Figure 9: 3.5" -SBC-RPL On-board Components- Top Side

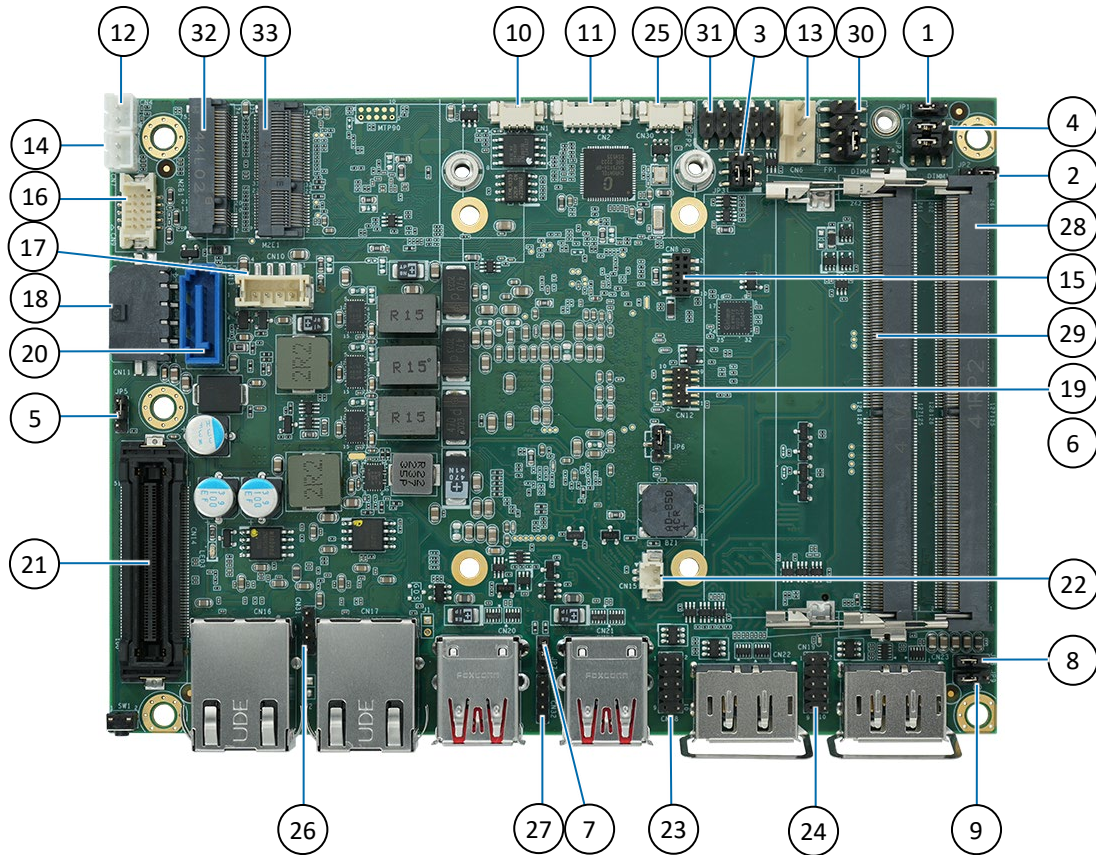

- |   |                                       |
|---|---------------------------------------|
| 1 Power Mode Selection Jumper   | 17 SATA Power Output Wafer            |
| 2 AT/ATX Power Mode Selection Jumper                                      | 18 Power Input Header                 |
| 3 eDP/LVDS Backlight Enable Voltage Selection Jumper                      | 19 SPI 10-pin Header                  |
| 4 eDP/LVDS Backlight Power & Panel Power Selection 1x Power button Jumper | 20 SATA Connector                     |
| 5 Flash Descriptor Security Override Selection Jumper                     | 21 Board-to-Board Connector           |
| 6 M.2 Key B Selection Jumper  | 22 RTC Power Input Wafer              |
| 7 USB Power Selection Jumper  | 23 USB 2.0 Port 5 & 6 Header          |
| 8 MFG Mode Selection Jumper   | 24 USB 2.0 Port 7 & 8 Header          |
| 9 Clear CMOS Selection Jumper   | 25 LVDS Backlight Control Wafer       |
| 10 S/PDIF Output Wafer  | 26 2.5 GbE ETH1 LED Indicator Header  |
| 11 SIM Card Wafer for M.2 Key B   | 27 2.5 GbE ETH2 LED Indicator Header  |
| 12 Left Channel Audio AMP Output Wafer                                    | 28 DDR5 Channel 1 SODIMM Slot         |
| 13 FAN Wafer  | 29 DDR5 Channel 2 SODIMM Slot         |
| 14 Right Channel Audio AMP Output Wafer                                   | 30 Front Panel Header 1               |
| 15 P80 Holder   | 31 Front Panel Header 2               |
| 16 Audio Input / Output Header  | 32 M.2 Key B 2242/3042/3052/2280 Slot |
|   | 33 M.2 Key E 2230 Slot                |

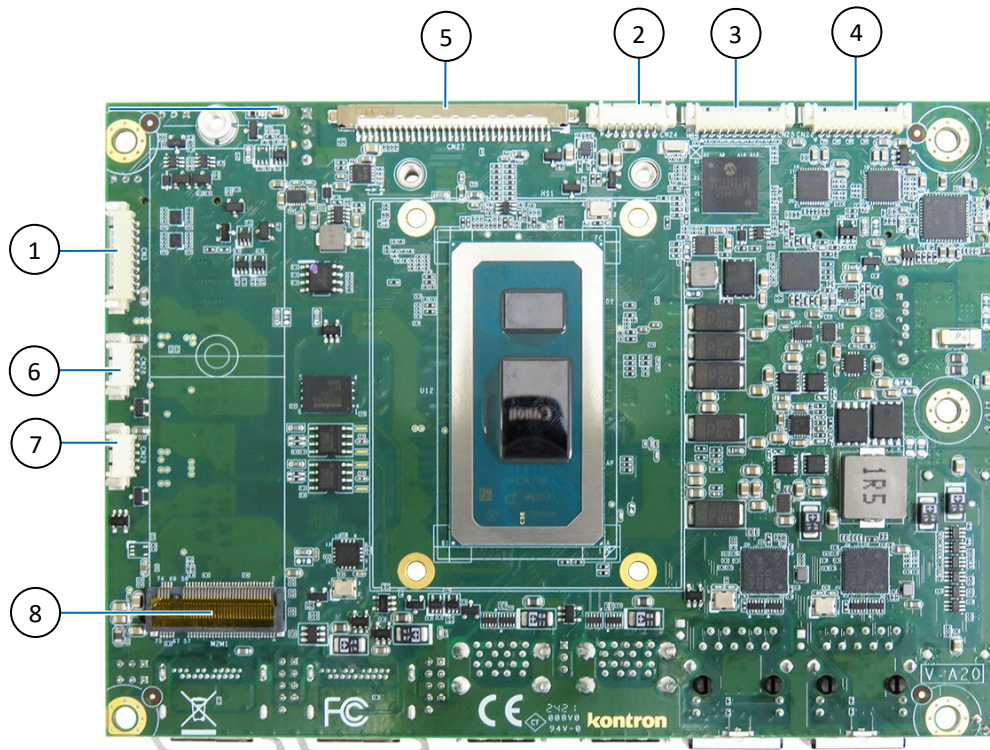
**Figure 10: 3.5"-SBC-RPL On-board Components- Bottom Side**

- |                                     |                                    |
|-------------------------------------|------------------------------------|
| 1. DIO Wafer                        | 5. eDP / LVDS Combo Connector      |
| 2. eDP / LVDS Backlight Power Wafer | 6. CAN Bus Port 1 Wafer (Optional) |
| 3. RS232 COM2 Wafer                 | 7. CAN Bus Port 2 Wafer (Optional) |
| 4. RS232 COM1 Wafer                 | 8. M.2 Key M 2280 Slot             |



For 3.5"-SBC-RPL on-board connector, header and jumper information, visit the [3.5"-SBC-RPL website](#).



The white arrow or white marking indicates the connector or jumper pin-1.

#### 4.6.2. RTC Lithium Battery

The default RTC lithium battery is BR2032, with the option for an automotive RTC lithium battery module with BR2450 with a longer lifetime (lifetime > 10 years).

An empty RTC lithium battery BIOS does not affect the BIOS settings. However, the system time and date are affected when the RTC battery is empty and must be reconfigured after replacing the battery.

The RTC lithium battery may over time need to be replaced. For instructions on how to replace the RTC Lithium battery, see Chapter 14/ Maintenance and Prevention.

Note that there is a risk of explosion if the lithium battery is replaced incorrectly (short-circuited, reverse-poled, wrong lithium battery type), for safety and disposal information see Chapter 2.5: Instructions for Lithium Battery.

## 5/System Expansion

The KBox A-151-RPL supports system expansion in the form of internally installed Wi-Fi, cellular LTE and Storage modules. In addition, the system expansion I/O door supports one factory installed expansion option and a custom front panel supports pre-defined front panel options.

### 5.1. Before Expanding

The expansion options are factory configured and are not accessible. Return the product to Kontron to replace or install internal components, see Chapter 15.1: Returning Defective Merchandise.

#### Protection label

#### NOTICE

The product is factory configured to meet customer requirements and then sealed with a protection label. Opening the product invalidates the warranty and may cause damage to internal components.



All M.2 modules are factory installed and require a special cooling solution. The addition of further M.2 modules in available M.2 slots means that the product will not be able to meet the product specification and compliance as defined within this user guide.

### 5.2. Internal Expansion Slots

The internal motherboard 3.5"-SBC-RPL supports three M.2 sockets with one M.2 socket in format 2230 with Key E, one M.2 socket in format 2242/3042/3052/2280 with Key B and one M.2 socket in format 2280 and Key M.

- › M.2 2280 Key M socket:
  - › Supports PCIe x4 signals.
  - › Used to integrate the storage expansion module.
- › M.2 2230 Key E socket:
  - › Supports PCIe x1, USB 2.0, and CNVi signals.
  - › Can be used to integrate the Wi-Fi/Bluetooth module.
- › M.2 2242/3042/3052/2280 Key B socket:
  - › Supports PCIe x1, USB 2.0 & SATA 3.0 signals as well as UIM signals connected to the SIM card wafer.
  - › Can be used to WWAN communication or other expansion options.

### 5.3. Storage Expansion

The internal M.2 NVMe SSD module is factory installed and not accessible in the field. Return the product to Kontron, for replacement or installation of the M.2 SSD module, see Chapter 15.1: Returning Defective Merchandise.

**Table 5: Storage SSD Module Specification**

Function	Reference Module Specification
Storage	Module: SSD NVMe Socket type: M.2 Key M 2280 Density: 256 GByte, 512 GByte, 1 TByte, 2 TByte Type: 3D NAND TLC Features: min. 3000 P/E cycles Power Consumption: 3.1 W @max. density 1 TByte

## 5.4. Wireless Expansion Options

### 5.4.1. Wi-Fi (option)

The Wi-Fi module is factory installed and not accessible in the field. Return the product to Kontron, for replacement of the module, see Chapter 15.1: Returning Defective Merchandise.

The M.2 Wi-Fi module populates the M.2 key E socket and as a result this socket is no longer available for other expansion options. Configuration of the Wi-Fi M.2 Key E module is always possible and independent of other Kontron expansion options.

The antenna position may affect the performance. Do not place the antenna close to a noise source that may cause interference. Kontron recommends the use of Kontron's reference antenna chosen to meet RF performance requirements and supports a nominal impedance of 50 ohms. The reference antennas are included in the delivery and available as an accessory, see Table 2: Accessories and Spare Parts.

**Table 6: Wi-Fi Module Specification**

Function	Reference Modules Description
Wi-Fi 6E/ Bluetooth® module	Module: Intel AX210 Connector: 2x RP-SMA (female) with center pin & outer thread Channels: 2x2 160 MHz Bandwidth: 2.4 Gbps Socket Type: M.2 Key E 2230 IEEE Standards: Wi-Fi: 802.11a/b/g/n/ac R2/ax R2(Pre-Standard) Bluetooth standard: V5.3 Interface: PCIe x1 (Wi-Fi) and USB 2.0 (Bluetooth®) MIMO Support: 2x2 MIMO Security levels: WPA, WPA2, WPA3 Power Consumption: 3 W max.

#### Antenna RF exposure

To avoid RF antenna exposure:

#### ⚠ CAUTION

- Avoid placing the antenna near people, minimum distance 20 cm.
- Avoid pointing the antenna at people.
- Keep a safe distance from the antenna especially when transmitting.

#### NOTICE

#### RP-SMA and SMA Antenna are not Interchangeable!

RP-SMA and SMA connectors and antenna are not electrically compatible. Incorrect connection may result in an insufficient connection or destroy the center pin.



Kontron recommends the use of Kontron's reference antenna included in the delivery and chosen to meet RF performance requirements, and to support a nominal impedance of 50 ohms, see Table 2: Accessories and Spare Parts.

### 5.4.2. Cellular LTE (option)

The cellular network's M.2 LTE module is factory installed and not accessible in the field. Return the product to Kontron, for replacement of the module, see Chapter 15.1: Returning Defective Merchandise.

The M.2 LTE module populates the M.2 key B socket and as a result this socket is no longer available for other expansion options Dual CAN, Dual GbE Ethernet, Dual Serial Port RS232 and EtherCAT.

Cellular LTE requires a SIM card that must be provided by the user for the required cellular network and inserted into the SIM slot on the front panel (X201) system expansion I/O door.

The antenna position may affect the performance. Do not place the antenna close to a noise source that may cause interference. Kontron recommends the use of Kontron's reference antenna chosen to meet RF performance requirements and supports a nominal impedance of 50 ohms. The reference antennas are included in the delivery and available as an accessory, see Table 2: Accessories and Spare Parts.

**Table 7: Cellular LTE Module Specification**

Function	Reference Module Specification
Cellular LTE Module	Module: Quetel EM05-G Series Connector: SMA (female) with pin socket and inner thread LTE: LTE Cat. 4 Data Rate: 150 Mbps download; 50 Mbps upload Socket Type: M.2 Key B 3042 Frequency. Bands: B1/B3/B7/B8/B20/B28/B38/B41 (global) Interface: USB 2.0 MIMO Support: Yes Power Consumption: 3.14 W max.

#### Antenna RF exposure

To avoid RF antenna exposure:

#### **CAUTION**

- Avoid placing the antenna near people, minimum distance 20 cm.
- Avoid pointing the antenna at people.
- Keep a safe distance from the antenna especially when transmitting.

#### **NOTICE**

#### RP-SMA and SMA Antenna are not Interchangeable!

RP-SMA and SMA connectors and antenna are not electrically compatible. Incorrect connection may result in an insufficient connection or destroy the center pin.



Prerequisite for Cellular LTE: 3.5" SBC board's M.2 Key B socket is free.



Kontron recommends the use of Kontron's reference antenna included in the delivery and chosen to meet RF performance requirements, and to support a nominal impedance of 50 ohms, see Table 2: Accessories and Spare Parts.

## 5.5. System Expansion I/O Door Options

All system expansion I/O door (X201) options are factory installed. The Cellular LTE, dual CAN, EtherCAT, dual RS232 serial ports, and dual 2.5 GbE Ethernet options can only be installed individually as they require the internal M.2 Key B socket. However, they may be combined with other options that do not require the M.2 Key B socket. The Wi-Fi and Cellular LTE options do not require interfaces on the system expansion I/O door (X201) and may be combined with other options requiring the system expansion I/O door (X201). The permitted system expansion combinations are shown in Table 8: System Expansion I/O Door Combination Overview.



The internal M.2 Key B socket must be free to implement a Cellular LTE, dual CAN, EtherCAT, dual Serial Port RS232 or dual LAN



The system expansion I/O door options are not available, in the custom front panel option

**Table 8: System Expansion I/O Door Combination Overview**

Combination Options	Wi-Fi/BT®	LTE	Dual CAN	Dual 2.5 GbE	EtherCAT	Dual RS232	Dual RSxxx	GPIO/DIO
Wi-Fi/BT®	✓	x	x	x	x	x	x	x
LTE	x	✓	-	-	-	-	x	x
Dual CAN	x	-	✓	-	-	-	-	-
Dual 2.5 GbE	x	-	-	✓	-	-	-	-
EtherCAT	x	-	-	-	✓	-	-	-
Dual Serial Port RS232	x	-	-	-	-	✓	-	-
Dual Serial Port RSxxx	x	x	-	-	-	-	✓	-
GPIO/DIO	x	x	-	-	-	-	-	✓

[✓] option considered

[ x ] possible additional options

[ - ] options not available

### 5.5.1. Dual 2.5 GbE Ethernet

The dual 2.5 GbE Ethernet option is factory installed in the system expansion I/O door and supports two 2.5 GbE isolated Ethernet ports.

For the pin assignment of the dual Ethernet ports, see Chapter 12.2.2: 2.5 GbE Port.

**Table 9: Dual 2.5 GbE Ethernet Module**

Function	Description
Dual 2.5 GbE LAN	<ul style="list-style-type: none"> <li>➤ Two isolated 2.5 GbE Ethernet ports</li> <li>➤ Two RJ45 Connectors, with speed and activity LEDs</li> <li>➤ Power Consumption, 3.08 W</li> <li>➤ Implements the EGPL-22S1-W1 (M.2 2280 Key B module)</li> </ul>



To achieve the specified performance of the Ethernet port, Category 5 twisted pair cables must be used with 10/100 MByte and Category 5E, 6 or 6E with 1 GbE/2.5 GbE networks.

### 5.5.2. Dual CAN Bus

The dual CAN option is factory installed in the system expansion I/O door and supports two CAN bus 2.0B ports that are both backwards compatible with CAN bus 2.0A and meet the requirements of ISO 11898-1.

For the pin assignment of the dual CAN Bus ports, see Chapter 12.2.1: CAN Bus Port.

**Table 10: Dual CAN Module**

Function	Description
Dual CAN	<ul style="list-style-type: none"> <li>➤ Two isolated CAN Bus 2.0B/J1939/CAN open</li> <li>➤ Backwards compatible with CAN Bus 2.0A</li> <li>➤ PCI Express 1.1 compliant</li> <li>➤ ISO 11898-1 compliant</li> <li>➤ Baud rates of 10/20/50/100/250/500/800/1000K</li> <li>➤ CAN message acceptance filter</li> <li>➤ Power Consumption, 2.83 W</li> <li>➤ Implements the EGPC-B2S1 (M.2 2280 Key B module)</li> </ul>

### 5.5.3. Dual Serial Ports (RS232)

The dual Serial Ports RS232 option is factory installed on the system expansion I/O door and supports two RS232 serial ports.

For the pin assignment of the two RS232 ports, see Chapter 12.2.3: Serial Port (RS232).

**Table 11: Dual Serial Ports RS232 Module**

Function	Description
Dual Serial Port RS232	<ul style="list-style-type: none"> <li>➤ Two RS232 serial outputs (with DB9 connectors)</li> <li>➤ Full RS232 functions</li> <li>➤ 4800bps to 921.6Kbps serial data rate</li> <li>➤ Power Consumption, 1.56 W</li> <li>➤ Implemented with: EGP2-X203-W1-U48 (M.2 2242 Key B module)</li> </ul>

### 5.5.4. Dual Serial Ports (RS232/422/485)

The dual Serial Port RS232/422/485 option is factory installed on the system expansion I/O door and supports two RS232/422/485 configurable serial ports. The default setting is RS232 mode. To reconfigure the default mode, users must access the internal USB to UART via a Windows or Linux software interface and program the new RS mode over USB. For this the USB to UARTs manufacture's software utility "FT\_PROG" is required.

For the pin assignment of the two RS232/422/485 ports, see Chapter 12.2.4: Serial Port (RS232/422/485 configurable).

**Table 12: Dual Serial Ports RS232/422/485 Module**

Function	Description
Dual Serial Port RS232/422/485	<ul style="list-style-type: none"> <li>➤ Two non-isolated RS232/422/484 ports (with DB9 connectors)</li> <li>➤ Default RS232 and configurable to RS422 and RS485</li> <li>➤ 300 baud to 3 Mbaud serial data rate</li> <li>➤ Implemented with: USB to Serial Controller FT231X</li> </ul>

To reconfigure the default RS232 mode by software under Windows or Linux, perform the following:

1. Download the USB to UARTs manufactures's FT\_PROG utility and user guide. For Windows visit the [FTDI Chip Utilities website](#) and for Linux visit the [FTx-PROG Linux repository](#).
2. Within the FT\_PROG utility set the CBUS signals to the parameters shown in Table 14: RS Mode Configuration, for the required RS mode and perform a power cycle by restarting the product after successful programming.

**Table 13: RS Mode Configuration**

CBUS Signal	RS232 (default)	RS422/RS485 FD (Full Duplex)	RS485 HD (Half Duplex)
C0 (direction)	TXDEN	TXDEN	TXDEN
C1 (mode0)	Drive_1	Drive_1	Drive_0
C2 (mode1)	Drive_0	Drive_1	Drive_1
C3 (termination)	Drive_0	Drive_0	Drive_0

### 5.5.5. EtherCAT Port

The EtherCAT option is factory installed in the system expansion I/O door and supports dual EtherCAT ports with Auto Crossover and switching between RX and TX. The connector's green LEDs indicate the link status, and the yellow LEDs indicate the network activity. Check the LED status to confirm an Ethernet connection.

For the pin assignment of the EtherCAT ports, see Chapter 12.2.5: 12.2.5: EtherCAT Port.

**Table 14: EtherCAT Module**

Function	Description
EtherCAT	<ul style="list-style-type: none"> <li>➤ Two RJ45 EtherCAT ports</li> <li>➤ Auto Crossover and switching between RX and TX</li> <li>➤ Power Consumption, 2.15 W</li> <li>➤ Implements the CFX M3042100BM-RE/F (M.2 3042 Key B module)</li> </ul>

#### **NOTICE**

#### **EtherCAT LAN Only**

Use EtherCAT RJ45 connectors for Ethernet only. Use for telecommunication is not possible.



For the EtherCAT interface use twisted pair cable of category 5 (CAT5) or higher, consisting of four twisted cores and with a maximum transfer rate of 100 MBit/s (CAT5).

### 5.5.6. 8-Channel GPIO/DIO

The 8-Channel GPIO/DIO is factory installed and supports eight GPIO bi-directional Digital IO (DIO) signals. Each of the eight GPIOs can be selected as an output or input channel.

The mating connector for the GPIO interface is not supplied with the product. For the 8-channel GPIO pin assignment with mating connector information, see Chapter 12.2.6: 8-Channel GPIO/DIO Connector.



Both resistive and inductive loads can be connected to the GPIO interface.



The mating connector for the 8-Channel GPIO/DIO connector is not included in the delivery.

The GPIO input channel specification supports the following GP Input:

**Figure 11: Input Application Connected to GPIO**

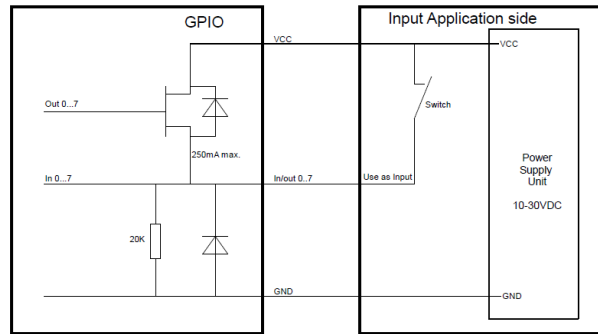
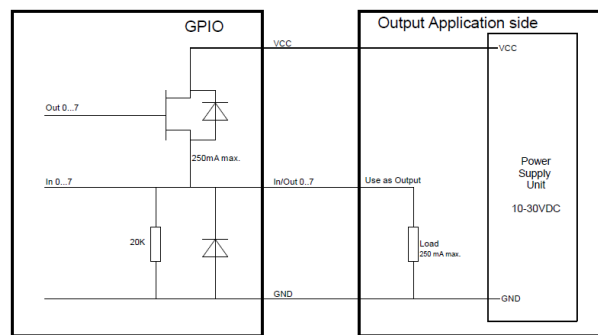

**Table 15: GPIO Input Channels Specification**

GPIO Input Channels	Description
Input Type	Input with integrated Pulldown resistor
Input Voltage	10 VDC to 30 VDC Max. GPIO input voltage depends on external Power IN Voltage (V GPIOx <= V Power IN)
Input Pulldown Resistor	20 Kohm approx.
Input High level	>8.8 V
Input Low Level	<4.2 V
Input Hysteresis	>2.5 V

The GPIO output channel specification supports the following GP Output:

**Figure 12: Output Application Connected to GPIO**



**Table 16: GPIO Output Channels Specification**

GPIO Output Channels	Description
Output Type	High side switch
Output Voltage	10 VDC to 30 VDC
Output Current	250 mA (Electrically limited to 500 mA max.)
Inductive Load Switch-off Energy Dissipation	40 mJ
Output Protection	<ul style="list-style-type: none"> <li>➤ Short-to-GND Protection by Current Limit.</li> <li>➤ Thermal Shut down with Output auto-retry.</li> <li>➤ Inductive Load Negative Voltage Clamp.</li> </ul>

### 5.5.7. Cellular LTE SIM Slot

The SIM card slot is factory installed in the system expansion I/O door, for configurations with cellular LTE. The SIM card slot option is only for use in combination with the cellular LTE network module and is not available for storage. Before inserting or extracting a SIM card, see Chapter 10/: Mobile Network.

For the pin assignment of the SIM slot, see Chapter 12.2.7: SIM Slot.

---

**NOTICE****Switch off to Insert/Extract SIM**

Only insert or extract the SIM cards if the product is switched off properly.

---



A SIM card is not part of the delivery and must be provided by the user, to support the required cellular network.

---

## 5.6. Custom Front Panel

The system expansion options with a custom front panel use Kontron's 3.5" extended I/O boards.

### 5.6.1. Dual Ethernet and Dual DisplayPorts

The dual Ethernet and dual DisplayPorts expansion option provide two additional 2.5 GbE Ethernet ports with speed and activity indication LEDs and two additional DisplayPort ports. This option deviates from the default product by supporting only one serial port and two antenna connectors on the front panel.

**Figure 13: Custom Front Panel with Dual Ethernet and Dual DP Ports**

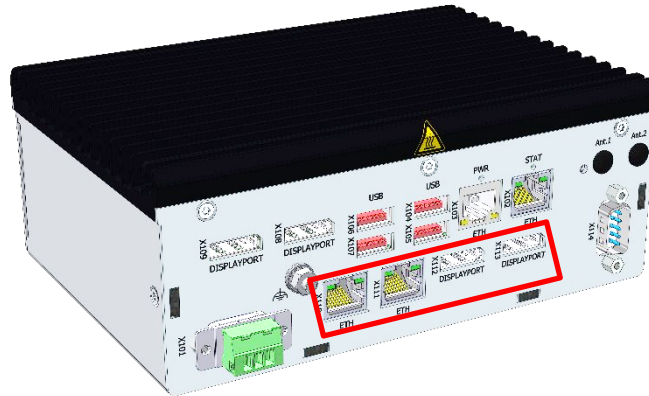

For the pin assignment of the Ethernet and DP ports, refer to Chapter 12.1.2: Ethernet 2.5 GbE Port (X102, X103) and Chapter 12.1.4: DisplayPort (X108, X109).



The 'Custom Front Panel' and 'System Expansion I/O Door' are mutually exclusive and only one may be selected. They cannot be implemented together!

---



For more information, visit the [3.5" Extended I/O Board with Dual DP and Dual 2.5 GbE](#) website.

---

## 6/Thermal and Power Management

### 6.1. Passive Cooling

The KBox A-151-RPL uses passive cooling via a heatsink and operates without a fan. All critical internal components are equipped with dedicated passive cooling solutions or are directly connected to the chassis to maximize heat transfer.

Observe a minimum clearance around the product, see Chapter 6.4 Minimum Clearance.

---

#### Ensure Sufficient Airflow

##### ⚠ CAUTION

Operate only in a well-ventilated environment that does not obstruct the airflow over the heatsink or obstruct the product from dissipating heat into the environment.

---

### 6.2. Heatsink

The heatsink on the top side can get very hot and precautions must be taken before handling or touching. Do not obstruct the airflow around the heatsink as this can stop sufficient heat dissipating into the ambient environment and cause a build-up of heat.



#### Hot Surface

Heatsinks can get very hot. To avoid burns and personal injury when handling the heatsink:

- › Do not touch while in operation
  - › Allow to cool before handling
  - › Wear protective gloves
- 

### 6.3. Mount Orientation

The product is designed and tested for vertical installation directly into a control cabinet environment. When mounting users must take care not to obstruct the airflow over the heatsink, as this can stop sufficient heat from dissipating into the ambient environment and cause a build-up of heat.

The orientation of the DIN Rail clamp can be changed by 180 degrees to support heatsink ventilation on the product's left or the right side.

---

#### Vertical Mounting Only

##### ⚠ CAUTION

The product has been designed and tested to be vertical mounting in a temperature-controlled environment, such as a control cabinet with vertical airflow.

When mounted horizontally, the thermal conditions described in this user guide may not be met, and performance limitations may become necessary. In such cases a temperature rating of 5°C must be considered.

---

### 6.4. Minimum Clearance

To provide maximum heat dissipation away from the heatsink a minimum clearance distance of 12 mm (0.47 inch) to the surrounding environment must be observed, also known as keep out area in this user guide, see Chapter 8.6: Clearance.

For sufficient air circulation around the product, Kontron recommends users not to mount or operate any other devices within the specified keep out area around the product.

**Clearance****⚠ CAUTION**

Leave sufficient clearance to prevent the product from overheating! To ensure proper operation observe the heatsink's specified minimum clearance of 12 mm (0.47 inch).

The product has been designed and tested for vertical mounting in a temperature controlled environment such as a control cabinet with vertical air cooling. If mounted horizontally the thermal conditions described within this user guide cannot be guaranteed and performance restrictions may be required.

## 6.5. Maximum Processor Power and Temperatures

The Intel® Core-I Raptor-Lake (RPL) family of processors provides internal thermal monitoring with a temperature sensor. To allow for optimal operation and long-term reliability, the processor must operate in the specified temperature range. To avoid overheating the processor performs automatic thermal management, to keep the processor temperature below the highest value of the temperature range.

**Table 17: Processor TDP and Maximum Temperature Values**

Processor	Description	Power	Temperature	
			DTR	T-Junction
Intel® U300E	5 Cores, 8 MB Cache & up to 4.3 GHz	15W	+/-70°C (158°F)	100°C (212°F)
Intel® Core™ i3-1315UE	6 Cores, 10 MB Cache & up to 4.5 GHz	15 W	+/-70°C (158°F)	100°C (212°F)
Intel® Core™ i3-1315URE			+/-110°C (230°F)	
Intel® Core™ i5-1345UE	10 Core, 12 MB Cache & up to 4.6 GHz	15 W	+/-70°C (158°F)	100°C (212°F)
Intel® Core™ i5-1345URE			+/-110°C (230°F)	
Intel® Core™ i7-1365UE	10 Core, 12 MB Cache & up to 4.9 GHz	15 W	+/-70°C (158°F)	100°C (212°F)
Intel® Core™ i7-1365URE			+/-110°C (230°F)	



Dynamic Temperature Range (DTR) defines the maximum temperature range during operation starting from boot time temperature and within the T-Junction limits. For further DTR information for your processor or a higher DTR-value, contact [Kontron Support](#).



T-Junction is the maximum junction temperature allowed at the processor die.

## 6.6. Power Consumption and Thermal Monitoring

The implemented Intel® processor series provides settings for maximal power consumption to help limit the thermal load. Changing these settings influences the performance of the application.

The product's ambient maximum temperature depends mainly on the power consumption of the processor and chipset on the 3.5"-SBC-RPL board and installed M.2 modules and connected USB devices. Typical power consumption values are provided in Table 18: Power Consumption.



The maximum system ambient temperature depends mostly on the power consumption of the processor, chipset and third-party components such as M.2 modules and USB devices.

**Table 18: Power Consumption**

Processor, 3.5"-SBC-RPL, M.2 & External Load		Absolute Max.		W/O External Load	W/O External Load & M.2
Intel® Core™ RPL i5 (PTat)	Processor TDP	15.0 W		15.0 W	15.0 W
3.5"-SBC-RPL Board	Board Losses	7.3 W		5.5 W	4.4 W
LAN 1 (BurnIn)	2.5 GbE	0.8 W		0.8 W	0.8 W
LAN 2 (BurnIn)	2.5 GbE	0.8 W		0.8 W	0.8 W
DP (BurnIn)	2x DP++	0.3 W		0.3 W	0.3 W
Serial Port (BurnIn)	1x	0.3 W		0.3 W	0.3 W
DC/DC	-	2.5 W		1.6 W	1.1 W
M.2 Key E	Work load	-	3.0 W	3 W	-
M.2 Key B	Work Load	8.0 W	5.0 W	5.0 W	-
USB 3.1	Type A	4.5 W		-	-
USB 3.1	Type A	4.5 W		-	-
USB 3.1	Type A	4.5 W		-	-
USB 3.1	Type A	4.5 W		-	-
<b>Total</b>		<b>53 W</b>		<b>32.3 W</b>	<b>22.7 W</b>



For the product's power specification, see chapter 11.4: Power Specification.

## 6.7. Configuring the Processor TDP

The TDP can be configured in the BIOS Advance setup menu, using the Configure TDP Boot Mode. The BIOS default setting is "Nominal" and possible settings are [Nominal, Low level, High level].

## 6.8. Third Party Components

The product is factory configured as ordered and requires no further hardware configuration with third party components by the user.

### NOTICE

#### Protection Label

Opening the product may damage internal components and invalidate the warranty.



If the product is modified with a third party product, the prerequisites for specific approvals may no longer apply!

## 7/Assembly

The KBox A-151-RPL is factory configured as ordered and then sealed with a protection label. No further initial assembly is required by the user before operation.

---

### **NOTICE**

#### **Protection label**

The product is factory configured to meet customer requirements and then sealed with a protection label. Opening the product invalidates the warranty and may cause damage to internal components.

---

### **⚠ CAUTION**

#### **Handling and Operation**

Handling and operation of the product is permitted only for skilled personnel aware of the associated dangers within an access-controlled workplace that fulfills all necessary technical and environmental requirements.

---

Return the product to Kontron to replace or install internal expansion options, see Chapter 15.1: Returning Defective Merchandise.

## 8/Installation

### 8.1. Before Installing

Before installing the KBox A-151-RPL in the operating environment, ensure that the operating environment meets the specification as stated within this user guide, and that there is sufficient access to the Power IN connector and front panel I/O connectors.

#### ⚠ CAUTION

##### Ensure Sufficient Airflow

Operate only in a well-ventilated environment that does not obstruct the airflow over the heatsink or obstruct the product from dissipating heat.

#### ⚠ CAUTION

##### Installation Environment

Do not install the product close to heat sources or damp places.

#### ⚠ CAUTION

##### Vertical Mounting Only

The product has been designed and tested to be vertical mounting in a temperature-controlled environment, such as a control cabinet with vertical airflow.

#### NOTICE

##### Support Cables

Support the power and I/O cables to minimize the strain on the product's connectors.

To install the product in an industrial control cabinet, using the factory installed DIN Rail clamp, rugged DIN-Rail clamp or Book Mount bracket, see Table 2: Accessories and Spare Parts.

### 8.2. DIN Rail Clamp (rear side)

The rear side DIN Rail clamp supports vertical airflow over the heatsink, and front access to all connectors and antennas. The DIN Rail clamp is reversible to enable the heatsink to be positioned on the left or right side when vertically mounted.

Figure 14: DIN Rail Clamp (50 mm x 50 mm)

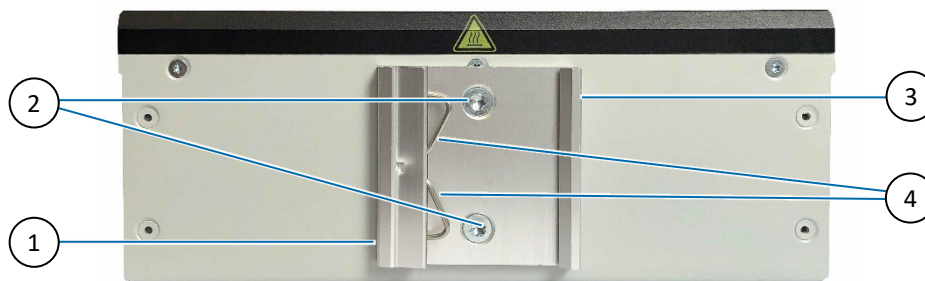

- |   |                            |   |                               |
|---|----------------------------|---|-------------------------------|
| 1 | DIN Rail clamp top bracket | 3 | DIN Rail clamp bottom bracket |
| 2 | Two screws                 | 4 | Spring                        |

#### NOTICE

##### Mounting Requirement

Always mount on the product using the two M4x6 TX screws included with the DIN Rail clamp.



The rear and bottom side DIN Rail clamps are not interchangeable due to a difference in size.

To attach the DIN Rail clamp on the rear side, perform the following:

1. Fasten the DIN Rail clamp firmly to the rear side of the product using the two M4x6 TX screws supplied and a thread locking compound to secure the two screws.
2. Clip the top bracket of the DIN Rail clamp with the two springs onto the top of the DIN Rail and push the DIN Rail clamp firmly downwards until the DIN Rail clamp's bottom bracket attaches to the bottom of the DIN Rail.

### 8.3. DIN Rail Clamp (bottom side)

The DIN Rail clamp is reversible to enable top or bottom side access to all connectors and antennas.

**Figure 15: DIN Rail Clamp (50 mm x 100 mm)**

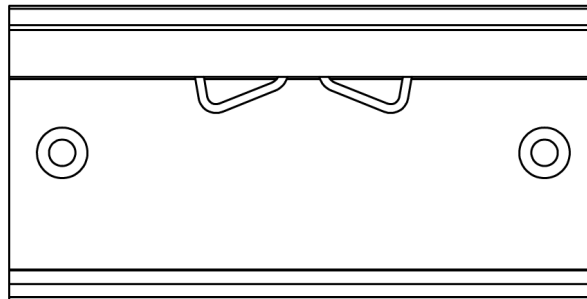

- 1 DIN Rail clamp top bracket with two screws
- 2 DIN Rail clamp bottom bracket

#### Vertical Mounting Only

#### CAUTION

The product has been designed and tested to be vertical mounting in a temperature-controlled environment, such as a control cabinet with vertical airflow.

When mounted horizontally, the thermal conditions described in this user guide may not be met, and performance limitations may become necessary. In such cases a temperature rating of 5°C must be considered.

#### NOTICE

#### Mounting Requirement

Always mount on the product using the two M4x6 TX screws supplied with the DIN Rail clamp.



The rear and bottom side DIN Rail clamps are not interchangeable due to a difference in size.

To attach the DIN Rail clamp, perform the following:

1. Fasten the DIN Rail clamp firmly to the bottom side of the product using the two M4x6 TX screws supplied and a thread locking compound to secure the two screws.
2. Clip the top bracket of the DIN Rail clamp with the two springs onto the top of the DIN Rail and push the DIN Rail clamp firmly downwards until the DIN Rail clamp's bottom bracket attaches to the bottom of the DIN Rail.

## 8.4. Rugged DIN Rail Clamp (rear side)

The rear side Rugged DIN Rail clamp supports vertical airflow over the heatsink and front access to all connectors and antennas. The Rugged DIN Rail clamp is reversible to enable the heatsink to be position of the left or right side when vertically mounted.

Figure 16: Rugged DIN Rail Clamp

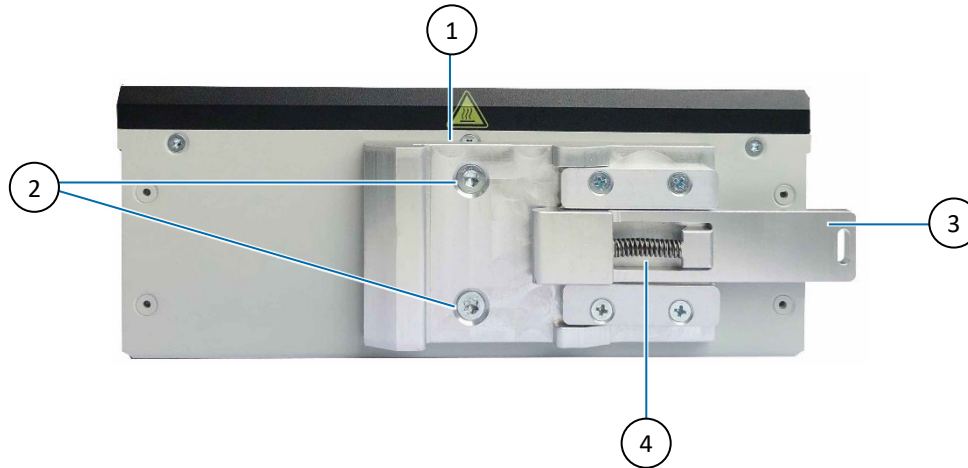

- |   |                 |   |                       |
|---|-----------------|---|-----------------------|
| 1 | Rugged DIN Rail | 3 | Rugged DIN Rail lever |
| 2 | Two Screws      | 4 | Spring                |

### NOTICE

#### Mounting Requirement

Always mount on the product using the two M4x6 TX screws supplied with the Rugged DIN Rail clamp.

To attach the Rugged DIN Rail clamp, perform the following:

1. Fasten the Rugged DIN Rail clamp firmly to the rear side of the product using the two M4x6 TX screws supplied and a thread locking compound to secure the two screws.
2. Clip the top bracket of the Rugged DIN Rail clamp onto the top of the DIN Rail and pull the lever with the spring firmly downwards until the Rugged DIN Rail clamp's bottom bracket attaches to the bottom of the DIN Rail.

## 8.5. Book Mount Bracket

To install the product on a flat mounting surface, fix the book mount bracket to the product's rear side or bottom side. For more information, see Table 2: Accessories and Spare Parts.

#### Mounting the Book Mount Bracket on the Mount Surface

### CAUTION

- › Always use four screws (M4x8, steel 4.8, DIN 7985/ISO 7045 or similar).
- › Mount on a flat surface.
- › Screw length depends on the thickness of the mounting surface.
- › Mount on a surface with a minimum thickness of 3 mm and made of aluminum or stronger

Figure 17: Book Mount Bracket

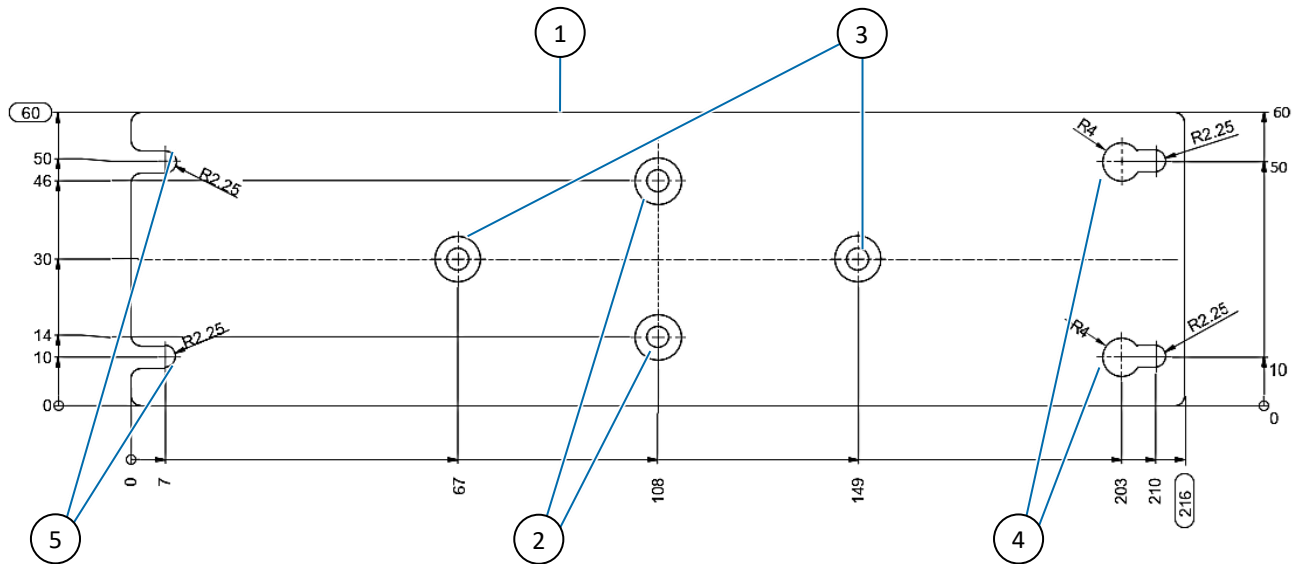

- |   |                              |   |                                |
|---|------------------------------|---|--------------------------------|
| 1 | Book mount bracket           | 3 | 2x M4x6 screws for bottom side |
| 2 | 2x M4x6 screws for rear side | 4 | 2x Key screw openings          |
|   |                              | 5 | 2x Slot screw openings         |

#### Mounting Requirement

#### NOTICE

Always mount on the product using the two M4x6 TX screws supplied with the book mount bracket.

To attach the book mount bracket on a flat surface, perform the following:

1. Fasten the book mount bracket (Figure 17, pos. 1) firmly to the rear side or bottom side (Figure 17, pos. 2 or pos. 3) of the product using the two M4x6 TX screws supplied and a thread locking compound to secure the two screws.
2. Attach the book mount bracket to a flat surface with a minimum thickness of 3 mm and made of aluminum or better using four (M4x8, steel 4.8, DIN 7985/ISO 7045 or similar) screws. Always use all four designated openings (Figure 17, pos. 4 and pos. 5) and a thread locking compound to secure the four screws. The four screws are to be supplied by the user, as the user environment dictates the required screw length.

## 8.6. Clearance

For sufficient air circulation around the product, Kontron recommends users not to mount or operate any other devices within the specified keep out areas around the product. The specified keep out areas for the product are displayed in Figure 18: Keep Out Areas- Vertical.

#### Clearance

#### CAUTION

Leave sufficient clearance (keep out area) to prevent the product from overheating! To ensure proper operation observe the specified minimum clearance of 12 mm (0.47 inch) for the heatsink.

The connector clearance (keep out area) on the front panel increases with the addition of antennas and depends on the type of Wi-Fi antenna used. Cable clearance depends on the installed connector types and antennas and is therefore user dependent.

**Figure 18: Keep Out Areas- Vertical**

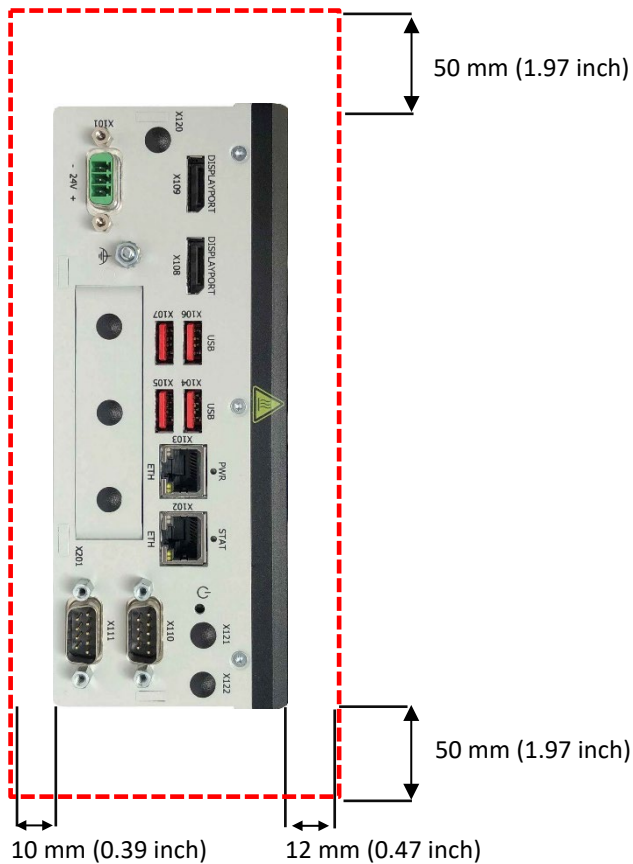

**Vertical Mounting Only**

**CAUTION**

The product has been designed and tested to be vertical mounting in a temperature-controlled environment, such as a control cabinet with vertical airflow. When mounted horizontally, the thermal conditions described in this user guide may not be met, and performance limitations may become necessary. In such cases a temperature rating of 5°C must be considered.

## 9/Starting UP

### 9.1. Before Starting

Before connecting the KBox A-151-RPL to power, read the instructions in this user guide and observe the safety instructions in Chapter 2/: General Safety Instructions. The product comes hardware configured and on request with a pre-installed Operating System (OS) and all the necessary drivers. Enabling full operation when connected to power and switched on for the first time.

---

#### Operated in Closed Condition Only

##### **⚠ WARNING**

It is only ensured that users do not have access to internal components during operation if the product is closed and secured.

---

#### External Power Supply

##### **⚠ CAUTION**

Only connect the product to an external power supply providing the voltage type (AC or DC) and the input power (max. current) specified on the Kontron Product Label and meeting the requirements of the Limited Power Source (LPS) and Power Source (PS2) of UL/IEC 62368-1.

---

#### Switch off Properly!

##### **⚠ CAUTION**

Even when switched off using the power button, parts of the product are still energized. The product is only completely switched off when the power has been switched off using the power button and the power cable is disconnected from the Power IN connector.

---

#### Protection

##### **⚠ CAUTION**

Observe that wiring and short-circuit/overcurrent protection is performed according to the applicable standards, regulations and in respect to the product's electrical specification.

---

#### Disconnection Device

##### **⚠ CAUTION**

If there is limited access to the power cable use a disconnecting device, (fuse/circuit breaker) rated in accordance with the product wire cross-section.

---

#### Cable Damage

##### **⚠ CAUTION**

Ensure that the power cable has no visible damage.

---

#### Proper Cabling Procedure

##### **NOTICE**

To prevent a false power-on condition, that could result in operational failure. When installing or disconnecting cables ensure that:

- › The functional earth connection is made first and disconnected last.
  - › The last connection made is to the Power IN Connector.
- 

#### Forced Shutdown

##### **NOTICE**

Disconnecting the power while the product is operating, performs a forced shutdown and can lead to loss of data or other undesirable effects! To shut down properly without data loss, switch off using the power button.

---

## 9.2. Connecting to an External 24 VDC Power Supply

### External Power Supply

#### ⚠ CAUTION

Only connect the product to an external power supply providing the voltage type (AC or DC) and the input power (max. current) specified on the Kontron Product Label and meeting the requirements of the Limited Power Source (LPS) and Power Source (PS2) of UL/IEC 62368-1.

To connect to the external 24 VDC power supply, perform the following:

1. Connect the ground to the functional earth bolt if not already connected.
2. Wire the supplied mating Power IN connector/terminal (PSC 1.5/3-F) as described, see Chapter 9.2.1: Wiring the Power IN Connector.
3. Switch off the external DC power supply via a disconnecting device (fuse/circuit breaker), to ensure that no power flows during the connection procedure.
4. Connect the functional earth bolt to an appropriate common earth connection.
5. Connect the wired mating Power IN connector (PSC 1.5/3-F) to the Power IN connector. Pay attention to the polarity of the connections.
6. Connect the other end of the wired mating Power IN connector to the external DC power supply.
7. When connected to power the STAT LED illuminates yellow. The PWR LED remains Off to indicate the product is not switched on.
8. Switched On and switched Off the product using the power button. When switched On the PWR LED Illuminates red.

### 9.2.1. Wiring the Power IN Connector

The Power IN connector connects to an external 24 VDC power supply using the mating Power IN connector (PSC 1.5/ 3-F) included in the delivery. Only connect to a power supply that meets the product's electrical specification as stated in this user guide and on the product's type label and provides the required safety and protection features.

The wiring is not part of the delivery and must be provided by the user. Use copper conductors only if the field wiring terminal is only for connection to copper wire and the field wiring terminals must have minimum temperature rating of 105° C. The wiring must be marked clearly with (+/-) to ensure a safe connection.

**Figure 19: Power IN Connector and Mating Power IN Connector**

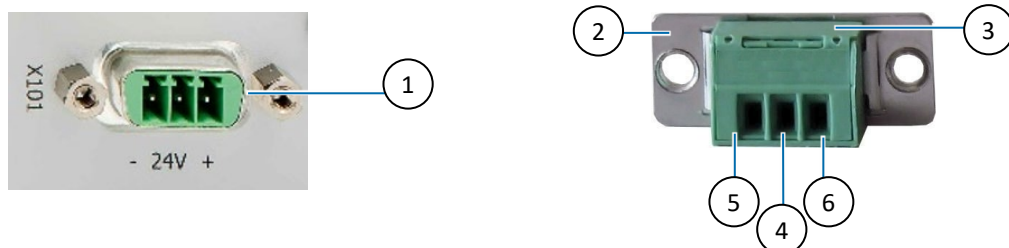

- |   |  |   |                        |
|---|--|---|------------------------|
| 1 | 3-pin Power IN connector (PSC 1.5/ 3-M)        | 4 | NC                     |
| 2 | 3-pin mating Power IN connector (PSC 1.5/ 3-F) | 5 | Clamp for GND (-) wire |
| 3 | Cover over the slotted pan head screws         | 6 | Clamp for VIN (+) wire |

To wire the supplied mating Power IN connector (PSC 1.5/ 3-F), perform the following:

1. Cut three (1 mm<sup>2</sup>) AWG18 isolated wires to the required length and strip each end 5 mm to 7 mm.
2. Twist the striped wire-ends and provide them with ferrules.
3. Access the slotted pan head screws by opening the mating Power IN connector's cover.
4. Loosen the slotted pan head screws far enough so that you can insert the end of the prepared wires.
5. Insert the wires into the corresponding clamp of the mating Power IN connector. Make sure that you have the right polarity of the connection.
6. Fasten the screws to secure the wires into the mating Power IN connector's clamps.
7. Close the cover on the mating Power IN connector.

---

#### Mark the Power Supply Wires

#### NOTICE

Mark the supply wires (+/-) clearly to ensure a safe connection from the Power IN connector to the external DC power supply.

---

### 9.3. Connecting to the AC/DC Power Supply

To connect the product to the delivered AC/DC power supply with power connector, perform the following:

1. Connect the ground to the functional earth bolt if not already connected.
2. Connect the AC/DC power supply to the Power IN connector using the Phoenix connector. Pay attention to the polarity of the connections
3. Connect the power cord for your region to the AC/DC power supply and then to the mains power source.
4. When connected to power the PWR LED is yellow, and the STAT LED remains 'Off' to indicate the product is switched Off.
5. Switched On and switched Off the product using the power button. When switched On the STAT LED is green.

### 9.4. Switching On/Off

Press the power button to switch on and when powered on, press the power button again to perform an orderly shutdown.

---

#### Switch off Properly!

#### CAUTION

Even when switched off using the power button, parts of the product are still energized. The product is only completely switched off when the power has been switched off using the power button and the power cable is disconnected from the Power IN connector.

---

#### Forced Shutdown

#### NOTICE

Disconnecting the power while the product is operating, performs a forced shutdown and can lead to loss of data or other undesirable effects! To shut down properly without data loss, switch off using the power button.

---

## 9.5. Operating System (OS) and Drivers

If ordered with a pre-installed operating system, all drivers are installed in accordance with the ordered configuration, and the product is operational when switched on for the first time. If ordered without a pre-installed operating system, users will need to install the operating system and the appropriate drivers for the configuration ordered.



To download relevant drivers for the factory installed internal hardware components, visit Kontron's [Customer Section](#).



Pay attention to the manufacturer's OS specifications relating to the integrated hardware components.

---

## 10/ Mobile Network

### 10.1. Before Setting Up

All software installed by the user is at the user's own risk. Kontron is not responsible for any malfunction, data loss, outage of services and other problems caused by software installed by the user. Kontron is not responsible for the loss of stored, transmitted, received and used data. It is the user's responsibility to consider access control, and the protection measures required to prevent unwanted access.

### 10.2. Setting up the Mobile Network

Kontron provides a Board Support Package (BSP) with an installer that includes the required drivers for the supported Wi-Fi and/or Cellular (LTE).

Kontron is not responsible for setup of the cellular network software and users must consider that setting up the product incorrectly can lead to the product becoming inaccessible. Kontron recommends testing the mobile network software in a safe test environment before installation in the end environment.



For the Board Support Package (BSP) and required drivers, visit Kontron's [Customer Section](#) and click on the KBox A > KBox A-151 to select Board Support Package/Drivers/Tools.

---

### 10.3. Inserting a SIM Card

The SIM card's push push insertion and extraction enable quick and easy insertion or extraction. The SIM card slot is only for use in combination with the cellular LTE system expansion module and is not available for storage.

To insert or extract a SIM card in the SIM slot on the front panel, see Chapter 14.3: Inserting and Extracting a SIM Card.

---

#### **NOTICE**

##### **Switch off to Insert/Extract SIM**

Only insert or extract the SIM cards if the product is switched off properly.

---



A SIM card is not part of the delivery and must be provided by the user, to support the required network.

---

# 11/ Product Specification

## 11.1. Block Diagram

The following block diagram is of the KBox A-151-RPL with the system expansion I/O door options.

Figure 20: Block Diagram KBox A-151-RPL

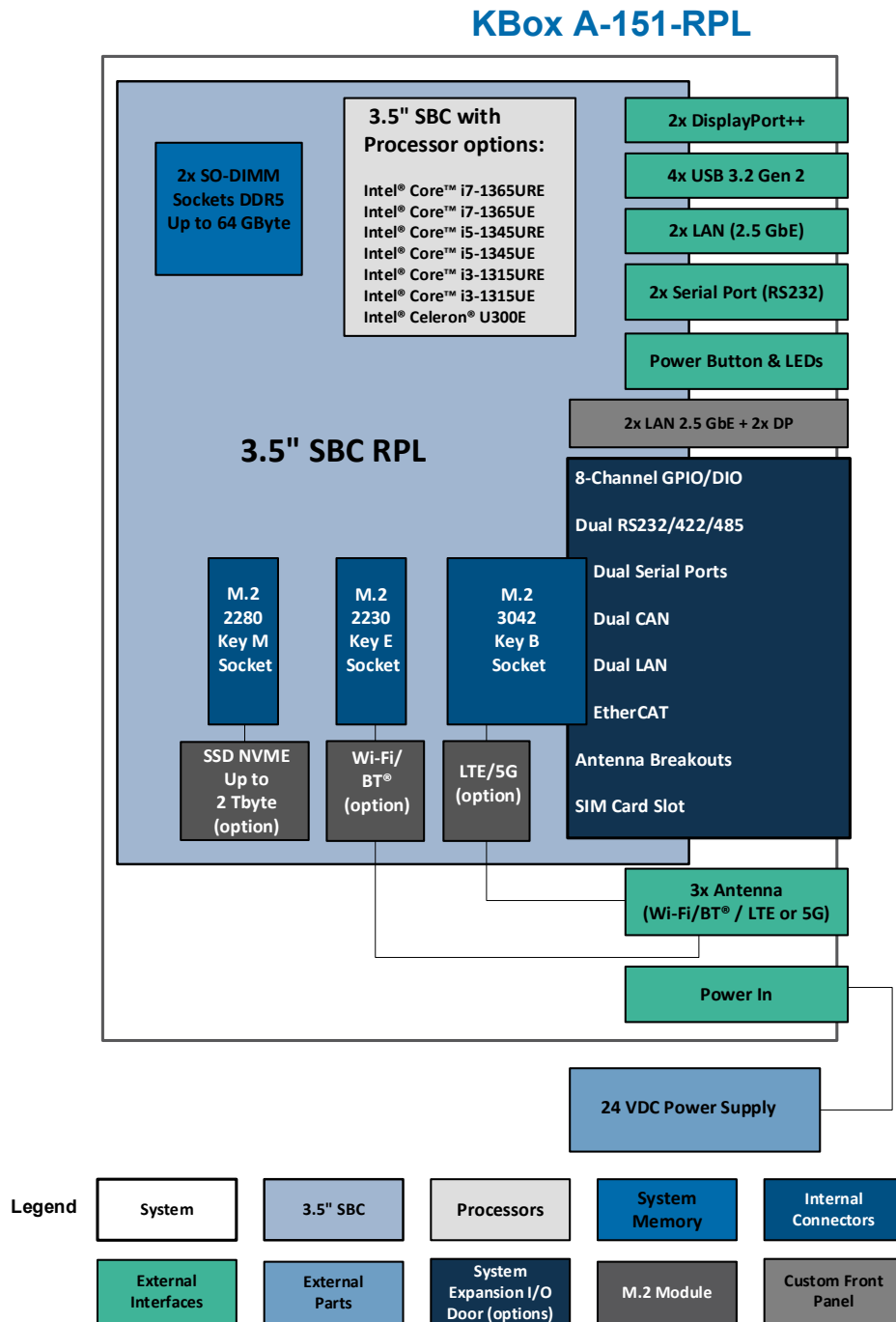

The 'Custom Front Panel' and 'System Expansion I/O Door' are mutually exclusive and only one may be selected. They cannot be implemented together!

## 11.2. Hardware Specification

**Table 19: Hardware Specification**

Hardware	Description					
<b>SBC</b>	3.5"-SBC-RPL					
<b>Processors</b>	<b>Type</b>	<b>Cores</b>	<b>Speed</b>	<b>TCC/ TSN</b>	<b>TDP (Base / Up/ Down)</b>	<b>TJunction</b>
	Intel® U300E	4	Up to 4.3 GHz		15 W /28 W / 12 W	100°C/212°F
	Intel® Core™ i3-1315UE	4	Up to 4.5 GHz		15 W /28 W / 12 W	100°C/212°F
	Intel® Core™ i3-1315URE <sup>[1]</sup>			✓		
	Intel® Core™ i5-1345UE	8	Up to 4.6 GHz		15 W /28 W / 12 W	100°C/212°F
	Intel® Core™ i5-1345URE <sup>[1]</sup>			✓		
	Intel® Core™ i7-1365UE	8	Up to 4.9 GHz		15 W /28 W / 12 W	100°C/212°F
	Intel® Core™ i7-1365URE <sup>[1]</sup>			✓		
<b>System Memory</b>	Up to 64 GByte max. (with 8 GByte, 16 GByte, 32 GByte) 2x SODIMM DDR5 per channel					
<b>Graphics</b>	Intel® Iris Xe Graphics or Intel® UHD Graphics Max. DP Resolution: 7680 x 4320 at 60 Hz					
<b>Front I/O</b>	2x DP++ 4x USB 3.2 Gen 2 2x 2.5 GbE 2x Serial Ports RS232 (without handshake)					
<b>Internal M.2 Sockets (options)</b>	Storage	SSD (NVMe): M.2 Key M 2280 (PCIe x4) SSD (3D NAND TLC) module 128 Gbyte, 256 GByte, 512 GByte, 1 TByte and 2 TByte				
	Wireless	Wi-Fi 6E: M.2 Key E 2230 (interface: PCIe x1 for Wi-Fi & USB 2.0 for Bluetooth®) module				
		Cellular LTE: <sup>[3]</sup> M.2 Key B 3042 (Interface: USB 2.0) module				
<b>System Expansion (options)</b>	I/O Door	Dual CAN Bus <sup>[2]</sup>				
		Dual 2.5 GbE <sup>[2]</sup>				
		Dual Serial Ports RS232				
		Dual Serial ports RS232/422/485				
		EtherCAT <sup>[2]</sup>				
		8-Channel GPIO/DIO				
		LTE SIM slot with two antenna breakouts <sup>[3]</sup>				
	Custom	Front Panel with Dual Ethernet + Dual DP				
<b>RTC Battery</b>	RTC lithium battery with cable Type: BR2032, 3V battery, lifetime > 3 years (default)					
	Automotive RTC lithium battery type BR2450, 3 V battery, lifetime > 10 years (option)					
<b>Power</b>	24 VDC Range: 10 VDC to 34 VDC [abs. max. 36 VDC] 80 W max.					

<sup>[1]</sup> UR temperature range is 0°C to 60°C and URE extended temperature range is -40°C to 60°C.

<sup>[2]</sup> M.2 key B socket can implement only one of the following: cellular LTE module, dual CAN Bus module, dual GbE module, dual Serial Ports RS232 or EtherCAT module.

<sup>[3]</sup> Cellular LTE requires a SIM slot in the system expansion I/O door. Other system expansion I/O door options are not available.

### 11.3. Software Specification

**Table 20: Software Specification**

Software	Description
Operating System (OS)	Windows 11 IoT Enterprise LTSC 2024 Windows 10 IoT Enterprise LTSC2021 Linux Debian
BIOS	AMI Aptio V



To access the KBox A 151-RPL Board Support Package (BSP) and BIOS Updates, visit Kontron's [Customer Section](#).

### 11.4. Power Specification

Before connecting the product to an external 24 VDC power supply, ensure that the power supply meets the electrical specification for the product as specified in this user guide and documented on the product's Type Label, and that protection and supply limitation have been taken into consideration. The power supply used must automatically recover from AC power loss and start up under peak loading. Connect the product only to a power supply designed to achieve NEC Class-2 and Limited Power Source (LPS) and used according to the manufacturer's instructions.

#### External Power Supply

##### ⚠ CAUTION

Only connect the product to an external power supply providing the voltage type (AC or DC) and the input power (max. current) specified on the Kontron Product Label and meeting the requirements of the Limited Power Source (LPS) and Power Source (PS2) of UL/IEC 62368-1.

#### Disconnection Device

##### ⚠ CAUTION

Observe that wiring and short-circuit/overcurrent protection is performed according to the applicable standards, regulations and in respect to the product's electrical specification. The disconnecting device (fuse/circuit breaker) rating must be in accordance with the product's wire cross-section.

#### Minimum Immunity

##### NOTICE

Ensure the external DC power supply has been fully tested to meet the minimum immunity of AC inputs requirements, as stipulated in IEC 55024. Including power supplies marketed with a separate AC/DC power converter.

#### Avoid Forced Shutdown

##### NOTICE

Do not disconnect the power while the product is operating!  
Performing a forced shutdown can lead to loss of data or other undesirable effects!

#### Power Cables

##### NOTICE

To protect the product and any connected peripherals, make sure that the power cables have the right diameter to withstand the maximum available current.

**Table 21: Electrical Specification 24 VDC**

Electrical Specification	Description
Input Voltage (nominal)	24 VDC
Input Voltage (range)	10 VDC to 34 VDC (absolute max. 36 VDC)
Input Power (max.)	80 W

### 11.4.1. Power Supply Protection Requirements

The external DC power supply is required to incorporate protection and supply features such as over current protection, inrush current protection, over voltage protection and under voltage (brownout) protection, to protect the product against fluctuations and interruptions in the delivered DC power supply.

#### Brownout

If an under voltage (brownout) condition occurs the used power supply must remain in the “off state” long enough to allow internal voltages to discharge sufficiently. Failure to observe this “off state” may mean that parts of the product or peripherals work incorrectly or suffer a reduction of MTBF. The minimum “off state”, to allow internal voltages to discharge sufficiently, is dependent on the power supply and additional electrical factors. To determine the required “off state”, each case must be considered individually. For more information, contact Kontron Support.

#### NOTICE

### 11.4.2. Power Consumption

The external power supply used must be capable of delivering the product with the required power when configured with all components. The total power consumption depends on factors such as the Processor, Chipset, 3.5"-SBC-RPL board and installed M.2 modules. Additionally, external devices connected using USB must be considered (USB 3.2 requires 4.5 W per port and USB-C requires 15 W per port), to establish the total power available for possible expansion. For a breakdown of the product’s power consumption, see Table 18: Power Consumption.

The total power requirement for the 24 Volt power supply depends on the product’s application. Be aware that the DC power supply must be able to handle peak currents for several seconds.



The maximum ambient temperature depends mostly on the power consumption of the processor, chipset, 3.5"-SBC-RPL board, installed M.2 modules and attached USB devices. For information regarding the maximum ambient temperature, see Chapter 6.5: Maximum Processor Power and Temperatures.

For a breakdown of the product’s power consumption, see Table 18: Power Consumption

### 11.4.3. Functional Earth

The functional earth bolt connects to the internal chassis ground.

#### Ground Properly

#### CAUTION

The installation site’s ground must meet your local, national and international region’s grounding requirements.

To avoid damage to the product, observe proper grounding methods:

1. Connect the product to ground before switching on the product.
2. Only connect the product to an applied ground that meets all applicable local, national and international grounding requirements.
3. When assembling, the first cable to be connected is the ground and when disassembling, the last cable to be removed is the ground cable.

## 11.5. Environmental Specification

**Table 22: Environmental Specification**

Environmental Specification	Description
<b>Temperature (Operating)</b>	Standard: 0°C to 60°C (32°F to 140°F) Extended: -40°C to 60° (-40°F to 140°F)
<b>Temperature (Non-Operating)</b>	-40°C to +85°C (-4°F to 185°F)
<b>Humidity</b>	According to IEC 60068-2-78 93% RH at 40°C, non-condensing
<b>Shock (Operating)</b>	According to IEC 60068-2-27 Peak Accel.: 15 g, Shock Dur.: 11 ms half sine, Shock Count: 3/direction, total 18
<b>Shock (Non-Operating)</b>	According to IEC 60068-2-27 Peak Accel. 30 g, Shock Dur. 11 ms half sine, Shock Count: 3/direction, total 18
<b>Vibration (Operating)</b>	According to IEC 60068-2-6 Frequency: 10 Hz - 150 Hz, Acceleration: 1 g
<b>Vibration (Non-Operating)</b>	According to IEC 60068-2-6 Frequency: 10 Hz - 150 Hz, Acceleration: 2 g
<b>Altitude (Operating)</b>	3,000 m max. (9,800 ft. max.)
<b>Altitude (Non-Operating)</b>	10,000 m max. (32,800 ft. max.)
<b>Cooling Solution</b>	Passive cooling solution via heatsink
<b>MTBF</b>	187,134 hours @ 30°C Ground Benign (GB) KBox A-151-RPL configured with 3.5"-SBC-RPL board with Intel® Core™ i5-1345UE processor, 16 GByte SODIMM and 256 GByte SSD.

## 11.6. Mechanical Specification

**Table 23: Mechanical Specification**

Mechanical Specification	Description
Material	Chassis: Steel Heatsink: Aluminium
Dimension (W x H x D)	180 mm x 70 mm x 123 mm (7.09" x 2.76" x 4.84")
Color	RAL7035, light grey (front panel and main chassis) Black (heatsink)
Mounting	DIN Rail clamp (rear or bottom sides) Book mount bracket (rear or bottom sides) Rugged DIN Rail clamp (rear side)
Weight	2 kg approx. (4.4 lbs. approx.)
IP Protection Class	IP20

**Figure 21: Mechanical Dimensions (mm)**

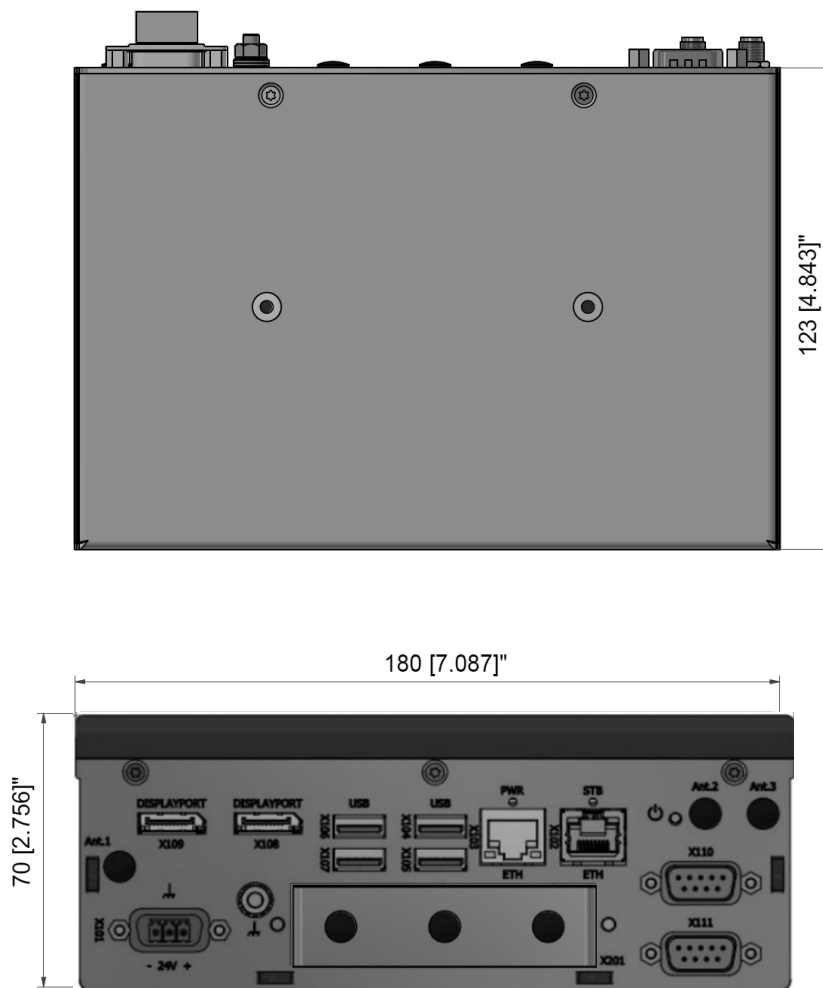

To access the KBox A 151-RPL STEP files, visit Kontron's [Customer Section](#).

## 11.7. Compliance

The KBox A-151-RPL complies with the relevant requirements and the approximation of the laws relating to CE Mark certifications and the standards that are constitutional parts of the declaration, or later thereof.

**Table 24: Compliance CE Mark**

Europe – CE Mark & UKCA	
<b>Directives</b>	<b>2014/30/EU</b> Electromagnetic compatibility <b>2014/35/EU</b> Low Voltage <b>2011/65/EU</b> RoHS II Restriction of the use of Hazardous Substances in electrical and electronic equipment
<b>EMC</b>	<b>EN 55032</b> Electromagnetic compatibility of multimedia equipment – Emission requirements <b>EN 61000-6-2</b> Electromagnetic compatibility of multimedia – Immunity requirements
<b>Safety</b>	<b>EN 61010-1</b> Safety requirements for electrical equipment for measurement, control and laboratory use - Part 1: General requirements

The KBox A-151-RPL plans to comply with the relevant requirements and the approximation of the laws relating to CE RED Mark certifications (for Wi-Fi/BT® and LTE) and the standards that are constitutional parts of the declaration, or later thereof.

**Table 25: Compliance RED mark**

Europe – CE RED Mark & UKCA	
<b>Directives</b>	<b>2014/53/EU</b> Radio Equipment Directive (RED) <b>2011/65/EU</b> RoHS II
<b>EMC</b>	<b>EN 55032</b> Electromagnetic compatibility of multimedia equipment- Emission Requirements <b>EN 61000-6-2</b> Electromagnetic compatibility (EMC), Part 6-2: Generic standards- Immunity for industrial environment <b>EN 300 328 V2.2.2</b> Wideband transmission systems - Data transmission equipment operating in the 2,4 GHz band <b>EN 301 893-2 V2.1.1</b> 5 GHz RLAN <b>EN 301 908-1 V15.2.1</b> IMT cellular networks - Harmonized Standard for access to radio spectrum, Part 1: Introduction and common requirements Release 15
<b>Safety</b>	<b>EN 61010-1</b> Safety requirements for electrical equipment for measurement, control and laboratory use - Part 1: General requirements

The KBox-A-151-RPL plans to comply with the following country specific certifications, or later thereof:

**Table 26: International Compliance**

USA/CANADA Certifications	
<b>EMC</b>	<p><b>FCC 47 CFR Part 15 (Class B) and ISDE RSS-Gen</b></p> <p>Complies with part 15 FCC rules and regulations of title 47 of the CFR rules for class B products; under which an unintentional radiator may be operated, administrated and other conditions relating to the marketing of part 15 devices and ISDE RSS-Gen, the General Requirement for Compliance of Radio Apparatus for Canada.</p>
<b>Safety</b>	<p><b>UL 61010-1 and CSA-C22.2 No. 61010-1</b></p> <p>Safety requirements for electrical equipment for measurement, control and laboratory use - Part 1: General requirements</p>



For the product Declaration of Conformity (DOC), visit Kontron's [Customer Section](#).



If the product is modified, the prerequisites for specific approvals may no longer apply.



Kontron is not responsible for any radio television interference caused by unauthorized modifications of the delivered product or the substitution or attachment of connecting cables and equipment other than those specified by Kontron. The correction of interference caused by unauthorized modification, substitution or attachment is the user's responsibility.

## 12/ Connectors and LEDs

This chapter describes the KBox A-151-RPL's external connectors, connector LEDs and relevant internal headers. For further motherboard information, visit Kontron's [3.5"-SBC-RPL](#) website.

### 12.1. Front Panel Connector Pin Assignments

#### 12.1.1. Power IN Connector (X101)

**Table 27: Power IN Connector Pin Assignment (X101)**

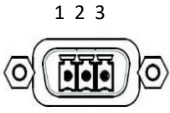
3-Pin Phoenix PSC 1.5/3-M	Pin	Signal Name	Description
	1	GND (-)	No isolation between Power IN GND (-) & system chassis. Include a functional earth.
	2		Connected to system chassis (Electrical connected to functional earth bolt.)
	3	VIN (+)	+24 VDC
<b>Mating Power Connector</b>	PSC 1.5/ 3-F		

#### Include a Functional Earth

#### ⚠ CAUTION

There is no isolation between Power IN GND (-) and the system chassis. Include a functional earth.

#### 12.1.2. Ethernet 2.5 GbE Port (X102, X103)

**Table 28: Ethernet 2.5 GbE Port Pin Assignment (X102, X103)**

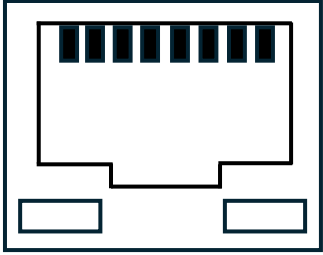
RJ45 (female)	Pin	Signal Name
	1	TX1+
	2	TX1-
	3	TX2+
	4	TX3+
	5	TX3-
	6	TX2-
	7	TX4+
	8	TX4-

LED: Speed		LED: Link Activity	
Off	10/100 Mbps	Off	Link down
Orange	1000 Mbps	Yellow Flashing	Link up and active
Green	2500 Mbps	Yellow	Link up and no activity

Signal	Description
TX1+ / TX1-	In MDI mode, this is the first pair in 2.5GBase-T and 1000Base-T, i.e. the BI_DA+/- pair, and is the transmit pair in 10Base-T and 100Base-TX. In MDI crossover mode, this pair acts as the BI_DB+/- pair, and is the receive pair in 10Base-T and 100Base-TX.
TX2+ / TX2-	In MDI mode, this is the second pair in 2.5GBase-T and 1000Base-T, i.e. the BI_DB+/- pair, and is the receive pair in 10Base-T and 100Base-TX. In MDI crossover mode, this pair acts as the BI_DA+/- pair, and is the transmit pair in 10Base-T and 100Base-TX.
TX3+ / TX3-	In MDI mode, this is the third pair in 2.5GBase-T and 1000Base-T, i.e. the BI_DC+/- pair. In MDI crossover mode, this pair acts as the BI_DD+/- pair.
TX4+ / TX4-	In MDI mode, this is the fourth pair in 2.5GBase-T and 1000Base-T, i.e. the BI_DD+/- pair. In MDI crossover mode, this pair acts as the BI_DC+/- pair.



To achieve the specified performance Category 5 twisted pair cables must be used with 10/100 MByte and Category 5E, 6 or 6E with 1 Gbit/2.5Gbit Ethernet networks.



The product is to be connected only to internal Ethernet networks without exiting a facility and being subjected to TNVs.

### 12.1.3. USB 3.2 Gen 2 Port (X104 to X107)

Table 29: USB Type A Port Pin Assignment (X104-X107)

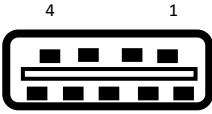
USB Type A	Pin	Signal Name	Description
	1	+USB_VCC	+5 V power supply for USB device
	2	USB_D-	USB 2.0 differential pair (-)
	3	USB_D+	USB 2.0 differential pair (+)
	4	GND	Ground
	5	USB_RX-	USB 3.2 receiver differential pair (-)
	6	USB_RX+	USB 3.2 receiver differential pair (+)
	7	GND	Ground
	8	USB_TX-	USB 3.2 transmitter differential pair (-)
	9	USB_TX+	USB 3.2 transmitter differential pair (+)



For USB 3.2 Gen 2 cabling, use only HiSpeed USB cable specified in the USB 3.2 Gen 2 standard.

### 12.1.4. DisplayPort (X108, X109)

**Table 30: DisplayPort Pin Assignment (X108, X109)**

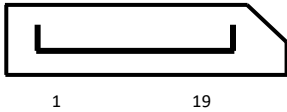
20-pin Standard DP Connector (female)	Pin	Signal Name	Pin	Signal Name
	1	ML_Lane0+	11	GND
	2	GND	12	ML_Lane3-
	3	ML_Lane0-	13	Config1
	4	ML_Lane1+	14	Config2
	5	GND	15	AUX_CH+
	6	ML_Lane1-	16	GND
	7	ML_Lane2+	17	AUX_CH-
	8	GND	18	Hot_Plug
	9	ML_Lane2-	19	GND
	10	ML_Lane3+	20	DP_PWR

Signal Name	Description
ML_Lane# +/-	DisplayPort Lane # transmitter differential pair (+/-)
Aux_CH +/-	DisplayPort Auxiliary channel differential pair (+)
Hot_Plug	DisplayPort hot plug detect
Config#	Connect to Ground directly or via a pulldown device
GND	Ground signal
DP_PWR	Power supply signal for connector



DisplayPort ++ supports the use of passive adapters to connect to HDMI or DVI.

### 12.1.5. Serial Port RS232 (X110, X111)

**Table 31: Serial Port (RS232) Pin Assignment (X110, X111)**

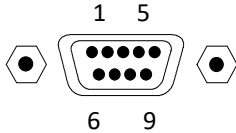





9-pin D-SUB (male)	Pin	RS232	Description
	1	DCD	Data Carrier Detect
	2	RxD	Received Data, receives data from the link.
	3	TxD	Transmitted Data, sends data to the link.
	4	DTR	Data Terminal Ready, indicates the UART is ready to establish a link.
	5	GND	GND signal
	6	-	-
	7	-	-
	8	-	-
	9	-	-

### 12.1.6. Antenna (X120, X121, X122)

The three antenna connectors (X120, X121, X122) are either Wi-Fi or cellular LTE. Wi-Fi and cellular LTE use different antenna types that are not electrically compatible and not interchangeable. All antennas are included in the delivery.

Kontron recommends that users only connect the delivered reference antenna chosen to meet product requirements. For more information regarding the reference antenna and the antenna requirements, see Table 2: Accessories and Spare Parts.

**Table 32: Antenna Type**

Antenna Connector	Antenna Description
<p>Wi-Fi/BT®</p>  <p>RP-SMA (female) with center pin and outer thread.</p>	<p>Wi-Fi Antenna</p>   <p>RP-SMA (male) antenna with pin socket and inner thread.</p>
<p>Cellular LTE</p>  <p>SMA (female) with pin socket and outer thread.</p>	<p>Cellular LTE Antenna</p>   <p>SMA (male) Antenna with center pin and inner thread.</p>

#### Antenna RF exposure

Avoid RF antenna exposure by:

**CAUTION**

- Avoid placing the antenna near people, minimum distance 20 cm.
- Avoid pointing the antenna at people.
- Keep a safe distance from the antenna especially when transmitting.

**NOTICE**

#### RP-SMA and SMA Antenna are not Interchangeable!

RP-SMA and SMA connectors and antenna are not electrically compatible. Incorrect connection may result in an insufficient connection or destroy the center pin.



The antenna position may affect the performance. Do not place the antenna close to a noise source that may cause interference.



Kontron recommends the use of Kontron’s reference antenna chosen to meet performance requirements. The reference antennas are included in the delivery and available as an accessory see Table 2: Accessories and Spare Parts.

## 12.2. System Expansion I/O Door Pin Assignments Options (X201)

The system expansion I/O door options must be factory installed. Only one of the system expansion I/O door options can be installed. The product can only be equipped with one of the following (Dual CAN Bus, Dual 2.5 GbE, Dual Serial Ports RS2323 or EtherCAT) if the M.2 2280 B socket is not populated with a Cellular LTE module.

### 12.2.1. CAN Bus Port

**Table 33: CAN Bus Port Pin Assignment**

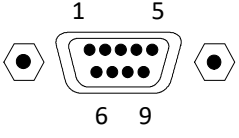
9-pin D89 port	Pin	Signal Name	Description	Pin	Signal Name	Description
	1		NC	6		NC
	2	CAN-L	Dominant low line	7	CAN-H	Dominant high line
	3	GND	CAN Ground	8		NC
	4		NC	9		NC
	5		NC			

### 12.2.2. 2.5 GbE Port

**Table 34: 2.5 GbE Ethernet Port Pin Assignment**

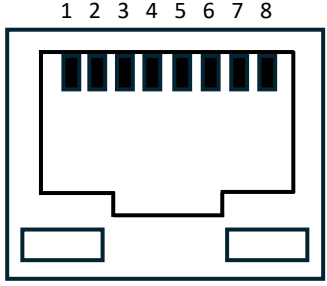
RJ45 (female)	Pin	Signal Name
	1	TX1+
	2	TX1-
	3	TX2+
	4	TX3+
	5	TX3-
	6	TX2-
	7	TX4+
	8	TX 4-

LED: Link Activity		Right LED: Speed	
Off	Link down	Off	10/100 Mbit/s
Green Flashing	Link up and active	Orange	1000 Mbit/s
Green	Link up and no activity		

Signal	MDI Mode Description
TX1+ / TX1-	In MDI mode, this is the first pair in 2.5GBase-T and 1000Base-T, i.e. the BI_DA+/- pair, and is the transmit pair in 10Base-T and 100Base-TX. In MDI crossover mode, this pair acts as the BI_DB+/- pair, and is the receive pair in 10Base-T and 100Base-TX.
TX2+ / TX2-	In MDI mode, this is the second pair in 2.5GBase-T and 1000Base-T, i.e. the BI_DB+/- pair, and is the receive pair in 10Base-T and 100Base-TX. In MDI crossover mode, this pair acts as the BI_DA+/- pair, and is the transmit pair in 10Base-T and 100Base-TX.
TX3+ / TX3-	In MDI mode, this is the third pair in 2.5GBase-T and 1000Base-T, i.e. the BI_DC+/- pair. In MDI crossover mode, this pair acts as the BI_DD+/- pair.
TX4+ / TX4-	In MDI mode, this is the fourth pair in 2.5GBase-T and 1000Base-T, i.e. the BI_DD+/- pair. In MDI crossover mode, this pair acts as the BI_DC+/- pair.

### 12.2.3. Serial Port (RS232)

**Table 35: Serial Port (RS232) Pin Assignment**

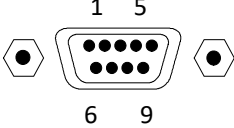
9-pin D-SUB (male)	Pin	RS232	Description
	1	DCD	Data Carrier Detect
	2	RxD	Received Data, receives data from the link.
	3	TxD	Transmitted Data, sends data to the link.
	4	DTR	Data Terminal Read y- UART is ready to establish a link.
	5	GND	GND signal
	6	DSR	Data Set Ready - modem etc. is ready to establish a link.
	7	RTS	Request To Send – indicated to modem etc. that UART is ready to send.
	8	CTS	Clear to send
	9	RI	Ring Indicator, indicates that the modem has received a ringing signal from the telephone line.

### 12.2.4. Serial Port (RS232/422/485 configurable)

**Table 36: Serial Port (RS232/422/485) Pin Assignment**

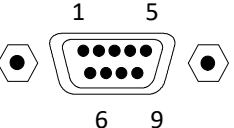
9-pin D-SUB (male)	Pin	RS232	RS422	RS485 (Full Duplex)
	1	DCD	TxD-	TxD/RxD-
	2	RxD	TxD+	TxD/RxD+
	3	TxD	RxD+	
	4	DTR	RxD-	
	5	GND	GND	GND
	6	DSR		
	7	RTS		
	8	CTS		
	9	RI		

Signal Name	Description
DCD	Data Carrier Detect
RxD+/-	Receive Data receives data from the communications link
TxD+/-	Transmitted Data sends data to the communications link
DTR	Data Terminal Ready indicates that the on-board UART is ready to establish communication link
DSR	Data Set Ready, indicates that the modem etc. is ready to establish a communications link.
RTS	Request To Send, indicates to the modem etc. that the on-board UART is ready to send.
CTS	Clear to send
RI	Ring Indicator indicates that the modem has received a ringing signal from the telephone line.
GND	GND signal

## 12.2.5. EtherCAT Port

**Table 37: EtherCAT Port Pin Assignment**

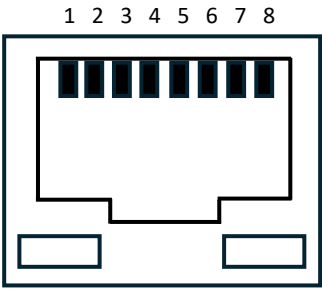
RJ45 Port (female)	Pin	Signal Name	Description
	1	TX+	Transmit data + channel
	2	TX-	Transmit data - channel
	3	RX +	Receive data + channel
	4	Term 1	Bridged and terminated to PE via RC link
	5	Term 1	
	6	RX -	Receive data - channel
	7	Term_2	Bridged and terminated to PE via RC link*
	8	Term_2	

LED: Link Green		LED Activity Yellow	
Off	No link to the Ethernet	Off	LED is not used
Green	Linked to the Ethernet but does not send or receive frames		
Green Flashing	Linked to the Ethernet and sends/receives Ethernet frames		

## 12.2.6. 8-Channel GPIO/DIO Connector

**Table 38: GPIO/DIO Connector Pin Assignment**

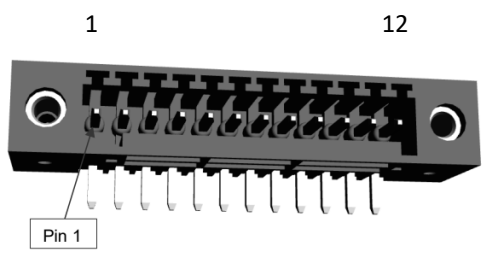
12-pin GPIO Connector	Pin	Signal Name	Direction	Description
	1	PWR_IN	Power	Power Input for the GPIOs 10 V to 30 V (fused with 3A)
	2	PWR_IN	Power	
	3			NC
	4	GPIO1	In/Out	GP Input /Output Channel
	5	GPIO2	In/Out	
	6	GPIO3	In/Out	
	7	GPIO4	In/Out	
	8	GPIO5	In/Out	
	9	GPIO6	In/Out	
	10	GPIO7	In/Out	
	11	GPIO8	In/Out	
	12	GND	Ground	Ground directly connected to system chassis (shield)

Mating Connector Information:



- 691381030012 WR-TBL Serie 381 or equivalent from Würth Elektronik
- 12-pin 2.50 mm vertical CAB entry plug screw less with Flanges
- Stranded Wire: 24-16 AWG / 0.205-1.31 mm<sup>2</sup>

### 12.2.7. SIM Slot

The SIM slot card holder supports one SIM card supplied by the user to support the user's cellular network

#### NOTICE

##### Switch off to Insert/Extract SIM

Only insert or extract the SIM cards if the product is switched off properly.



A SIM card is not part of the delivery and must be provided by the user, to support the required network.

## 12.3. On-board Header Pin Assignments

This chapter provides the pin assignment of relevant on-board headers.

### 12.3.1. RTC Lithium Battery Power Input Header

The motherboard RTC Lithium battery header connects to the lithium battery. The lithium battery provides power to the system clock to retain the time when the power is switched off. To replace the lithium battery, see Chapter 14/: Maintenance and Prevention.

**Table 39: RTC Power Input Header Pin Assignment**

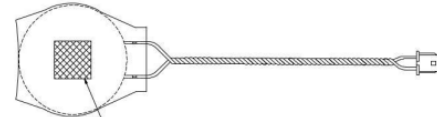
2-pin, 1.25 mm Pitch	Pin	Signal Name	Description
	1	+VRTC	Real-time clock backup lithium battery input
	2	GND	Ground
<b>Mating Lithium Battery</b>			
BR2032	Red	+	
	Black	-	



The RTC Lithium battery BR2032 and the optional Automotive RTC Lithium battery BR2450 both use the RTC Lithium Battery on-board header.

## 13/ BIOS

The KBox A-151-RPL uses the AMI Aptio V uEFI BIOS based on the Unified Extensible Firmware Interface (uEFI) specification and the Intel® Platform Innovation Framework for EFI. The uEFI BIOS preferences are preset and do not require further adjustment for operation.

The UEFI BIOS Setup menus and available selections are open to change. For specific information on the BIOS for your product, visit Kontron's [Customer Section](#), and access the KBox A-151-RPL information.



UEFI only! No legacy support and no Master Boot Record (MBR) installation.



For the latest uEFI BIOS Information, visit Kontron's [Customer Section](#) to download the BIOS. If the information you require is not available within the Customer Section, contact [Kontron Support](#).

### 13.1. Starting the uEFI BIOS

The uEFI BIOS's Setup program provides quick and easy access to the individual functions within the BIOS sub-menus for control or modification of the uEFI BIOS configuration.

Use the navigation hot keys, to navigate the BIOS. The hot key legend bar is located at the bottom right of each Setup screen. For a list of navigation hot keys, see Table 40: Navigation Hot Keys.

**Table 40: Navigation Hot Keys**

Sub-screen	Description
<F1>	<F1> key invokes the General Help window
<->	<Minus> key selects the next lower value within a field
<+>	<Plus> key selects the next higher value within a field
<F2>	<F2> key loads previous values
<F3>	<F3> key loads optimized defaults
<F4>	<F4> key Saves and Exits
<←> or <→>	<Left/Right> arrows select major Setup menus on menu bar, for example, Main or Advanced
<↑> or <↓>	<Up/Down> arrows select fields in the current menu, for example, Setup function or sub-screen
<ESC>	<ESC> key exits a major Setup menu and enters the Exit Setup menu Pressing the <ESC> key in a sub-menu displays the next higher menu level
<RETURN>	<RETURN> key executes a command or selects a submenu

To start the uEFI BIOS Setup program, follow the steps below:

1. Switch on the product.
2. Wait until the first characters appear on the screen (POST messages or splash screen).
3. Press the <DEL> key.
4. If the uEFI BIOS is password-protected, a request for password will appear. Enter either the User Password or the Supervisor Password, press <RETURN>, and proceed with step 5.
5. The BIOS setup utility appears in the Main menu.

6. Use the Navigation Hot Keys arrow keys to navigate to the required Setup menu to “change,” or “reset,” settings.
7. Navigate using Navigation Hot Key arrow keys to the “Save & Exit” Setup menu and select “Save Changes”.

## 13.2. BIOS Update

To ensure compatibility with new OS, hardware, software or to integrate new BIOS functions Kontron recommends performing regular BIOS updates. Additionally, if a problem cannot be solved using a new driver, Kontron recommends updating the BIOS.

For the latest BIOS downloads and release information, visit Kontron’s [Customer Section](#) and access the 3.5-SBS-RPL BIOS information. The BIOS information includes the latest version of the BIOS update and the preferred method to update the BIOS with instructions.



To discover your current BIOS version, refer to the Kontron BIOS Version number within the Main setup menu.

## 13.3. Setup Menus

The Setup menus listed in the selection bar at the top of the screen are:

- › Main
- › Advanced
- › Chipset
- › Security
- › Boot
- › Save & Exit

The current active menu and active BIOS Setup item are highlighted in white. Use the left and right arrow keys to select the Setup menus.

Each Setup menu is made up of two main frames. The left frame displays all available functions. Configurable functions are displayed in blue. Functions displayed in grey provide information about the status or the operational configuration. The right frame displays an explanation of the respective function in a help window.

### NOTICE

#### Advanced Setup Menu – Caution when Changing

Making changes within the Advanced Setup menu without understanding the full implications may cause system malfunction.

Kontron recommends users to make changes only when the user is sure of the impact.



Functions displayed in “grey” in the following setup menus and tables provide information about the status or the operational configuration of the product but are not selectable and not changeable.

## 13.4. Main Setup Menu

The Main Setup menu provides basic system information and functions for setting the system time and date.

**Figure 22: Main Setup Menu Example**

Aptio Setup - AMI					
Main	Advanced	Chipset	Security	Boot	Save & Exit
<b>Product Information</b>					
Product Name	3.5-SBC-RPL				
<b>BIOS Information</b>					
BIOS Vendor	American Megatrends				
Core Version	5.32				
Compliance	UEFI 2.9 ; PI 1.7				
Kontron BIOS Version (KBOX151RPL100)	RPLUVEXR.140 (x64)				
Access Level	Administrator				
<b>FPS Information</b>					
FSP version	0D.01.DE.40				
RC version	0C.00.DE.40				
Build Date					
FSP Mode	Dispatch Mode				
<b>Processor Information</b>					
Name	RaptorLake ULT				
Type	13 <sup>th</sup> Gen Intel® Core™ i3-1315UE				
Speed	1200 MHz				
ID	0xB06A3				
Stepping	Q0				
Package	Not Implemented Yet				
Number of Efficient-cores	4Core(s) / 4Thread(s)				
Microcode Revision	4121				
GT Info	0xA7A9				
IGFX GOP Version	21.0.1065				
Memory RC Version	0.0.4.224				
Total Memory	16384 MB				
Memory Frequency	5200 MHz				
<b>PCH Information</b>					
Name	PCH-P				
PCH SKU	RPL-P: Premium				
Stepping	A1				
ChipsetInit Base Revision	2				

Aptio Setup - AMI					
Main	Advanced	Chipset	Security	Boot	Save & Exit
ChipsetInit OEM Revision		0			
Package		Not Implemented Yet			
TXT Capability of Plattform/PCH		Unsupported			
Production Type		Production			
Dual Output Fast Read support		Supported			
Read ID/Status Clock Freq		50 MHz			
Write and Erase Clock Freq		50 MHz			
Fast Read Clock Freq		50 MHz			
Fast Read support		Supported			
Number of Components		1 Component			
SPI Component 0 Density		32 MB			
eSPI Flash Sharing Mode		G3			
EC PECI Mode		Legacy PECI mode			
ME FW Version		16.1.30.2307			
ME Firmware SKU		Consumer SKU			
PMC FW Version		160.1.0.1020			
<b>System Language</b>		[English]			
<b>► Platform Information</b>					
Board Information					
Product Name		3.5-SBC-RPL			
Serial#		XXXXXXXX			
UUID		XXXXXXXX-XXXX-XXXX-XXXX-XXXXXXXXXXXX			
<b>KSC Information</b>					
Controller		KSC Main Controller			
Operating Mode		Normal			
Board Name		3.5-RPL			
Platform ID		000C			
KSC Spec. Version		1.20			
BIOS Protocol Version		2.3.1			
BIOS SW Spec. Version		1.18			→ ←: Select Screen
Core Firmware Version		1.4.1 Release			↑ ↓: Select Item
Board Firmware Version		1.0.0 Release			Enter: Select
SCM Info		30-F4-D1-45			+/-: Change Opt.
Boot counter		N/A			F2: Previous Values
					F3: Optimized Defaults
System Date		xxx xx/xx/xxxx			F4: Save & Reset
System Time		xx:xx:xx			ESC: Exit

### 13.5. Advanced Setup Menu

Figure 23: Advanced Setup Menu Example

Aptio Setup - AMI					
Main	Advanced	Chipset	Security	Boot	Save & Exit
Configurable TDP Mode			[Nominal]		
In-Band ECC Support			[Disabled]		
Compliance Test Mode			[Disabled]		
HD Audio			[Enabled]		
Power Mode Selection			AT Mode		
Resore AC Power Loss			Power Off		
Power Saving Mode			[Disabled]		
ME FW Image Re-Flash			[Disabled]		
Unconfigure ME			[Disabled]		
AMT BIOS Feature			[Disabled]		
▶ Display Configuration					
▶ Trusted Computing					
▶ ACPI Settings					
▶ Miscellaneous					
▶ MEBx					
▶ H/W Monitor					
▶ S5 RTC Wake Settings					
▶ Serial Port Console Redirection					
▶ SIO Configuration					
▶ USB Configuration					
▶ Network Stack Configuration					
▶ NVME Configuration					
▶ CH7513A Configuration					
▶ F81435 Configurations					
▶ Intel® Ethernet Controller I226-V – XX:XX:XX:XX:XX:XX					
▶ Intel® Ethernet Controller I226-V – XX:XX:XX:XX:XX:XX					
▶ Driver Health					
				→ ←: Select Screen	
				↑ ↓: Select Item	
				Enter: Select	
				+/-: Change Opt.	
				F1: General Help	
				F2: Previous Values	
				F3: Optimized Defaults	
				F4: Save & Reset	
				ESC: Exit	

**Table 41: Advanced Setup Menu Sub-screens Example**

Sub-screen	BIOS Default	Possible Settings
Configurable TDP Boot Mode	Nominal	Nominal, Low Level, High Level
In-Band ECC Support	Disabled	Disabled, Enabled
Compliance Test Mode	Disabled	Disabled, Enabled
HD Audio	Enabled	Disabled, Enabled
Power Mode Selection	ATX Mode	
Resore AC Power Loss	Power Off	Power Off, Last State
Power Saving Mode	Disabled	Disabled, Enabled
ME FW Image Re-Flash	Disabled	Disabled, Enabled
Unconfigure ME	Disabled	Disabled, Enabled
AMT BIOS Features	Disabled	Disabled, Enabled

**Display Configuration**

Sub-screen	BIOS Default	Possible Settings
Display Configuration		
VBT Select	DP	DP, HDMI
Primary Display	IGFX	Auto, IGFX, PEG Slot; PCH PCI
Internal Graphics	Enabled	
Aperture Size	256MB	128MB, 256MB, 512MB, 1024MB

**Trusted Computing**

Sub-screen	BIOS Default	Possible Settings
TPM 2.0 Device Found		
Firmware Version	16.13	
Vendor	IFX	
Security Device Support	Enable	Disabled, Enable
Active PCR banks	SHA256	
Available PCR banks	SHA256,SHA384	
SHA256 PCR Bank	Enabled	Disabled, Enabled
SHA384 PCR Bank	Disabled	Disabled, Enabled
Pending Operation	None	None, TPM Clear
Platform Hierarchy	Enabled	Disabled, Enabled

Sub-screen	BIOS Default	Possible Settings
Storage Hierarchy	Enabled	Disabled, Enabled
Endorsement Hierarchy	Enabled	Disabled, Enabled
Physical Presence Spec Version	1.3	1.2, 1.3
TPM 2.0 InterfaceType	TIS	
Device Select	Auto	TPM 1.2, TPM 2.0, Auto

### ACPI Settings

Sub-screen	BIOS Default	Possible Settings
ACPI Settings		
Enable ACPI Auto Configuration	Disabled	Disabled, Enabled
Enable Hibernation	Enabled	Disabled, Enabled
ACPI Sleep State	S3 (Suspend to RAM)	Suspend Disabled, S3 (Suspend to RAM)

### Miscellaneous

Sub-screen	BIOS Default	Possible Settings
Miscellaneous Configuration		
▶ Present DIO in BIOS		
GPIO OS usable	GPIO 0 – GPIO 7	All available GPIO, GPIO 0 – GPIO 7
Control DIO in BIOS	Disabled	Disabled, Enabled
▶ Control KSC firmware		
Lock FW update access	Enabled	Disabled, Enabled
▶ KSC OTP area control		
KSC OTP access lock	Enabled	Disabled, Enabled
▶ Update KSC firmware		
Auto update KSC FW	Enabled	Disabled, Enabled
▶ Generic eSPI Decode Rangers		
Generic LPC via eSPI Decode 1	Disabled	Disabled, Enabled
▶ Watchdog		
Auto-reload	Disabled	Disabled, Enabled
Global Lock	Disabled	Disabled, Enabled
WDT Strobe	Disabled	Disabled, Enabled
Stage 1 Mode	Disabled	Disabled, Reset, Delay, WDT Signal only
Reset Button Behavior	Disabled	Chipset Reset, Power Cycle

Sub-screen	BIOS Default	Possible Settings
I2C Speed	100 KHz	100 KHz, 400 KHz, 1 MHz
On-board I2C Mode	Multimaster	Multimaster, Busclear
Manufacturing Mode	Disabled	
BIOS Test Mode	Disabled	
Last system reset through	Power-on reset	
PCIe Wake	Enabled	Disabled, Enabled
On-board EEPROM Write Protect	WP Enabled	WP Disabled, WP Enabled

## MEBX

Sub-screen	BIOS Default	Possible Settings
Interl® ME Password		

## H/W Monitor

Sub-screen	BIOS Default	Possible Settings
KSC based H/W Monitor		
Temperature sensors:		
#1: CPU Temp	x xxx.x C	
#2: PCH Temp	x xxx.x C	
#3: System Temp	x xxx.x C	
Voltage sensors:		
#1: V_IN	xx.x V	
#1: 12V_S0	xx.x V	
#1: 5V_S0	xx.x V	
#1: 3V3_S0	xx.x V	
#1: 3V_BAT	xx.x V	
Fan speed & control:		
#1: CPU FAN	x RPM	
Fan Control	Auto	Disabled, Manual, Auto
Signal Filter Control	Auto	Disabled, Manual, Auto
Signal Filer	Enabled	
Fan Pulse	Auto	Auto, 1, 2, 3, 4, 5, 6, 7, 8
Fan Pulse	2	

Sub-screen	BIOS Default	Possible Settings
Fan Speed Control	Auto	Auto, 1, 2, 3, 4, 5, 6, 7, 8
Fan Speed Control	Normal	
Reference Temperature	All Temperatures	#1: CPU Temp, #2: PCH Temp, #3: System Temp, All Temperatures
▶ Fan Trip Point Table		
Fan 1 Automode	Internal table	Internal table, User table

### S5 RTC Wake Settings

Sub-screen	BIOS Default	Possible Settings
Wake system from S5	Disabled	Disabled, Fixed Time, Dynamic Time

### Serial Port Console Redirection (COM0, COM1, EMS)

Sub-screen	BIOS Default	Possible Settings
COM0		
Console Redirection	Disabled	Disabled, Enabled
▶ Console Redirection Settings		
Terminal Type	ANSI	VT100, VT100Plus, VT-UTF8, ANSI
Bits per second	115200	9600, 19200, 38400, 57600, 115200
Data Bits	8	7, 8
Parity	None	None, Even, Odd, Mark, Space
Stop Bits	1	1, 2
Flow Control	None	None, Hardware RTS/CTS
CT-UTF8 Combo Key Support	Enabled	Disabled, Enabled
Recorder Mode	Disabled	Disabled, Enabled
Resolution 100x31	Disabled	Disabled, Enabled
Putty KeyPad	VT100	VT100, LINUX, XTERMR6, SCO, ESCN, VT400
COM1		
Console Redirection	Disabled	Disabled, Enabled
▶ Console Redirection Settings		
Terminal Type	ANSI	VT100, VT100Plus, VT-UTF8, ANSI
Bits per second	115200	9600, 19200, 38400, 57600, 115200
Data Bits	8	7, 8
Parity	None	None, Even, Odd, Mark, Space

Sub-screen	BIOS Default	Possible Settings
Stop Bits	1	1, 2
Flow Control	None	None, Hardware RTS/CTS
CT-UTF8 Combo Key Support	Enabled	Disabled, Enabled
Recorder Mode	Disabled	Disabled, Enabled
Resolution 100x31	Disabled	Disabled, Enabled
Putty KeyPad	VT100	VT100, LINUX, XTERMR6, SCO, ESCN, VT400
Legacy Control Redirection		
▶ Legacy Console Redirection Settings		
Serial Port for Out-of-Band Management / Windows Emergency Management Services (EMS)		
Console Redirection EMS	Disabled	Disabled, Enabled
▶ Console Redirection Settings		
Out-of-Band Mgmt Port	COM0	COM0 COM1
Terminal Type EMS	VT-UTF8	VT100, VT100Plus, VT-UTF8, ANSI
Bits per second EMS	115200	9600, 19200, 57600, 115200
Flow Control EMS	None	None, Hardware RTS/CTS
Data Bits EMS	8	
Parity EMS	None	
Stop Bits EMS	1	

### SIO Configuration (Serial Port 0, Serial Port 1)

Sub-screen	BIOS Default	Possible Settings
AMI SIO Driver Version: A5.19.00		
WARNING: Logical Device state on the left side of the control reflects the current Logical Device state. Changes made during Setup Session will be shown after you restart the system.		
Super IO Chip Logical Device(s) Configuration		
▶ [*Active*] Serial Port 0		
Serial Port 0 Configuration		
Use This Device	Enabled	Disabled, Enabled
Logical Device Settings:		
Current: IO=3F8h; IRQ=4;		

Sub-screen	BIOS Default	Possible Settings
Possible:	Use Automatic Settings	Use Automatic Settings IO=3F8h; IRQ=4; IO=3F8h; IRQ=4; IO=2F8h; IRQ=3
Warning: Disabling SIO Logical Device may have unwanted side effects. PROCEED WITH CAUTION.		
▶ [*Active*] Serial Port 1		
Serial Port 1 Configuration		
Use This Device	Enabled	Disabled, Enabled
Logical Device Settings:		
Current: IO=2F8h; IRQ=3;		
Possible:	Use Automatic Settings	Use Automatic Settings IO=2F8h; IRQ=3; IO=2F8h; IRQ=3; IO=3F8h; IRQ=4
Warning: Disabling SIO Logical Device may have unwanted side effects. PROCEED WITH CAUTION.		

## USB Configuration

Sub-screen	BIOS Default	Possible Settings
USB configuration		
USB Module Version 34		
USB Controllers:		
2 XHCIs		
USB Devices:		
xxxxxxx		
Legacy USB Support	Enabled	Disabled, Enabled, Auto
XHCI Hand-off	Disabled	Disabled, Enabled
USB Mass Storage Driver Support	Enabled	Disabled, Enabled
USB hardware delays and time-outs:		
USB transfer time-out	20 sec	1 sec, 5 sec, 10 sec, 20 sec
Device reset time-out	20 sec	10 sec, 20 sec, 30 sec, 40 sec

Sub-screen	BIOS Default	Possible Settings
Device power-up delay	Auto	Auto, Manuel

### Network Stack Configuration

Sub-screen	BIOS Default	Possible Settings
Network Stack	Disabled	Disabled, Enabled
IPv4 PXE Support	Disabled	Disabled, Enabled
IPv4 HTTP Support	Disabled	Disabled, Enabled
IPv6 PXE Support	Disabled	Disabled, Enabled
IPv6 HTTP Support	Disabled	Disabled, Enabled
PXE boot wait time	0	0-5
Media detect count	1	1-50

### NVME Configuration

Sub-screen	BIOS Default	Possible Settings
NVMe Configuration		
No NVME Device Found		

### CH7513A Configuration

Sub-screen	BIOS Default	Possible Settings
CH7513A Configuration (DP/eDP to LVDS Convertor)		
LFP Selection	Disabled	Disabled, LVDS, eDP

### eDP Configurations

Sub-screen	BIOS Default	Possible Settings
eDP Configurations		
Backlight Source Selection	Controlled by PCH	Controlled by PCH Controlled by EC

**F81435 Configurations**

Sub-screen	BIOS Default	Possible Settings
F81435 Configurations (Multiprotocol RS232/RS422/RS485 Transceiver)		
COM1 Mode Selection	RS232	RS422 Single Master, RS232, RS485 with Auto Flow Control, RS422 Multi Master
COM1 Transceiver	Normal mode	Shut down mode, Normal mode
COM1 Internal Terminator Switch Control	Terminator switch is disabled.	Terminator switch is disabled. Terminator switch is enabled.
COM1 External Terminator Switch Control	Terminator switch is disabled.	Terminator switch is disabled. Terminator switch is enabled.
COM2 Mode Selection	RS232	RS422 Single Master, RS232, RS485 with Auto Flow Control, RS422 Multi Master
COM2 Transceiver	Normal mode	Shut down mode, Normal mode
COM2 Internal Terminator Switch Control	Terminator switch is disabled.	Terminator switch is disabled. Terminator switch is enabled.
COM2 External Terminator Switch Control	Terminator switch is disabled.	Terminator switch is disabled. Terminator switch is enabled.

**Intel 2.5G Ethernet Controller**

Sub-screen	BIOS Defaults	Possible Setting
Intel 2.5G Ethernet Controller I226LM-XX:XX:XX:XX:XX:XX		

**Intel 2.5G Ethernet Controller**

Sub-screen	BIOS Defaults	Possible Setting
Intel 2.5G Ethernet Controller I226LM-XX:XX:XX:XX:XX:XX		

**Drive Health**

Sub-screen	BIOS Defaults	Possible Setting
▶ Intel® 2.5G Ethernet Controller 0.10.06 Healthy		
▶ Intel® Ethernet Controller 0.10.06 Healthy		
▶ Intel® 2.5G Ethernet Controller 0.10.06 Healthy		
▶ Intel® Ethernet Controller 0.10.06 Healthy		

### 13.6. ChipSet Setup Menu

Figure 24: Chipset Setup Menu Example

Aptio Setup - AMI					
Main	Advanced	Chipset	Security	Boot	Save & Exit
<ul style="list-style-type: none"> <li>▶ System Agent (SA) Configurations</li> <li>▶ PCH-IO Configuration</li> </ul>					
				→ ←: Select Screen ↑ ↓ : Select Item Enter: Select +/-: Change Opt. F1: General Help F2: Previous Values F3: Optimized Defaults F4: Save & Reset ESC: Exit F4: Save & Reset	

The following table gives more information about important setup options within the Chipset Menu.

Table 42: Chipset Setup Menu Sub-screens Example

#### System Agent (SA) Configuration

Sub-screen	BIOS Defaults	Possible Setting
System Agent (SA) Configuration		
VT-D	Supported	
▶ Graphics Configuration		
Graphics Turbo IMON Current	31	14-31
Skip Scnning of External Gfx Card	Disabled	Disabled, Enabled
Select PCIE Card	Auto	Auto, Elk Creek 4, PEG Eval
HG Delay After Power Enable	300	300
HG Delay After Hold Reset	100	100
▶ External Gfx Card Primary Display Configuration		
GTT Size	8MB	2MB, 4MB, 8MB

Sub-screen	BIOS Defaults	Possible Setting
PSMI SUPPORT	Disabled	Disabled, Enabled
DVMT Total Gfx Mem	256M	128M, 256M, MAX
Igfx Gsm2	0GB	0GB, 2GB, 4GB, 6GB, 8GB, 10GB, 12GB, 14GB, 16GB, 18GB, 20GB, 22GB, 24GB, 26GB, 28GB, 30GB, 32GB
Intel Graphics Pei Display Peim	Disabled	Disabled, Enabled
VDD Enable	Enabled	Disabled, Enabled
Configure GT for use	Enabled	Disabled, Enabled
RC1p Support	Disabled	Disabled, Enabled
PAVP Enable	Enabled	Disabled, Enabled
Cdynmax Clamping Enable	Disabled	Disabled, Enabled
Cd Clock Frequency	Max CdClock freq based on Reference Clk	192 Mhz, 307.2 Mhz, 556.8 Mhz, 652.8 Mhz, Max CdClock freq based on Ref. Clk
Enable Display Audio Link in Pre-OS	Disabled	Disabled, Enabled
IUER Button Enable	Disabled	Disabled, Enabled
▶ LCD Control		
LCD Panel Type	VBIOS Default	VBIOS Default 640x480 LVDS 800x600 LVDS 1024x768 LVDS 1280x1024 LVDS 1400x1050 LVDS 1400x1050 LVDS 1600x1200 LVDS 1280x768 LVDS 1280x1050 LVDS 1680x1050 LVDS 1920x1200 LVDS 1600x900 LVDS 1280x800 LVDS 1280x600 LVDS 2048x1536 LVDS 1366x768 LVDS
Panel Scaling	Auto	Auto, Off, Force Scaling
Backlight Control	PWM Normal	PWM Inverted, PWM Normal
Active LFP	eDP Port-A	No eDP, eDP Port-A
Panel Color Depth	18 Bit	18 Bit, 24 Bit
Backlight Brightness	255	255

Sub-screen	BIOS Defaults	Possible Setting
▶ Intel® Ultrabook Event Support		
IUER Slate Enable	Disable	Disabled, Enabled
IUER Dock Enable	Disable	Disabled, Enabled
VT-d	Enabled	Disabled, Enabled
Above 4GB MMIO BIOS assignment	Enabled	Disabled, Enabled

## PCH-IO Configuration

Sub-screen	BIOS Defaults	Possible Setting
PCH-IO Configuration		
▶ PCI Express Configuration		
DMI Link ASPM Control	Auto	Disabled, L0s, L1, L0L1, Auto
Port8xh Decode	Disabled	Disabled, Enabled
PCIe function swap	Enabled	Disabled, Enabled
PCH PCIE Clock Gating	Disabled	Disabled, L0s, L1, L0L1, Auto
PCH PCIE Power Gating	Disabled	Disabled, L0s, L1, L0L1, Auto
▶ PCIe EQ settings		
PCIe EQ override	Disabled	Disabled, Enabled
PCI Express Root Port 1	Lane configured as USV/SATA/UFS	
PCI Express Root Port 2	Lane configured as USV/SATA/UFS	
PCI Express Root Port 3	Lane configured as USV/SATA/UFS	
PCI Express Root Port 4	Lane configured as USV/SATA/UFS	
▶ PCI Express Root Port 5		
PCI Express Root Port 5	Enabled	Disabled, Enabled
Connection Type	Slot	Built-in, Slot
ASPM	Auto	Disabled, L1, Auto
L1 Substates	L1.1 & L1.2	Disabled, L1.1, L1.1 & L1.2

Sub-screen	BIOS Defaults	Possible Setting
L1 Low	Enabled	Disabled, Enabled
ACS	Enabled	Disabled, Enabled
PTM	Enabled	Disabled, Enabled
DPC	Disabled	Disabled, Enabled
EDPC	Enabled	Disabled, Enabled
URR	Disabled	Disabled, Enabled
FER	Disabled	Disabled, Enabled
NFER	Disabled	Disabled, Enabled
CER	Disabled	Disabled, Enabled
SEFE	Disabled	Disabled, Enabled
SENF	Disabled	Disabled, Enabled
SECE	Disabled	Disabled, Enabled
PME SCI	Enabled	Disabled, Enabled
Hot Plug	Disabled	Disabled, Enabled
Advanced Error Reporting	Enabled	Disabled, Enabled
PCIe Speed	Auto	Auto, Gen1, Gen2, Gen3
Transmitter Half Swing	Disabled	Disabled, Enabled
Detect Timeout	0	0-65535
Extra Bus Reserved	0	0-7
Reserved Memory	10	1-20
Reserved I/O	4	4-20
PCH PCIe LTR Configuration		
LTR	Enabled	Disabled, Enabled
Snoop Latency Override	Auto	Disabled, Manual, Auto
Non Snoop Latency Override	Auto	Disabled, Manual, Auto
LTR Lock	Disabled	Disabled, Enabled
Peer Memory Write Enable	Disabled	Disabled, Enabled
PCI Express Root Port 6	Shadowed by x2/x4 port	
▶ PCI Express Root Port 7		
PCI Express Root Port 7	Enabled	Disabled, Enabled
Connection Type	Slot	Built-in, Slot

Sub-screen	BIOS Defaults	Possible Setting
ASPM	Auto	Disabled, L1, Auto
L1 Substates	L1.1 & L1.2	Disabled, L1.1, L1.1 & L1.2
L1 Low	Enabled	Disabled, Enabled
ACS	Enabled	Disabled, Enabled
PTM	Enabled	Disabled, Enabled
DPC	Disabled	Disabled, Enabled
EDPC	Enabled	Disabled, Enabled
URR	Disabled	Disabled, Enabled
FER	Disabled	Disabled, Enabled
NFER	Disabled	Disabled, Enabled
CER	Disabled	Disabled, Enabled
SEFE	Disabled	Disabled, Enabled
SENF	Disabled	Disabled, Enabled
SECE	Disabled	Disabled, Enabled
PME SCI	Enabled	Disabled, Enabled
Hot Plug	Disabled	Disabled, Enabled
Advanced Error Reporting	Enabled	Disabled, Enabled
PCIe Speed	Auto	Auto, Gen1, Gen2, Gen3
Transmitter Half Swing	Disabled	Disabled, Enabled
Detect Timeout	0	0-65535
Extra Bus Reserved	0	0-7
Reserved Memory	10	1-20
Reserved I/O	4	4-20
PCH PCIe LTR Configuration		
LTR	Enabled	Disabled, Enabled
Snoop Latency Override	Auto	Disabled, Manual, Auto
Non Snoop Latency Override	Auto	Disabled, Manual, Auto
LTR Lock	Disabled	Disabled, Enabled
Peer Memory Write Enable	Disabled	Disabled, Enabled
▶ PCI Express Root Port 8		
PCI Express Root Port 8	Enabled	Disabled, Enabled
Connection Type	Slot	Built-in, Slot
ASPM	Auto	Disabled, L1, Auto

Sub-screen	BIOS Defaults	Possible Setting
L1 Substates	L1.1 & L1.2	Disabled, L1.1, L1.1 & L1.2
L1 Low	Enabled	Disabled, Enabled
ACS	Enabled	Disabled, Enabled
PTM	Enabled	Disabled, Enabled
DPC	Disabled	Disabled, Enabled
EDPC	Enabled	Disabled, Enabled
URR	Disabled	Disabled, Enabled
FER	Disabled	Disabled, Enabled
NFER	Disabled	Disabled, Enabled
CER	Disabled	Disabled, Enabled
SEFE	Disabled	Disabled, Enabled
SENF	Disabled	Disabled, Enabled
SECE	Disabled	Disabled, Enabled
PME SCI	Enabled	Disabled, Enabled
Hot Plug	Disabled	Disabled, Enabled
Advanced Error Reporting	Enabled	Disabled, Enabled
PCIe Speed	Auto	Auto, Gen1, Gen2, Gen3
Transmitter Half Swing	Disabled	Disabled, Enabled
Detect Timeout	0	0-65535
Extra Bus Reserved	0	0-7
Reserved Memory	10	1-20
Reserved I/O	4	4-20
PCH PCIe LTR Configuration		
LTR	Enabled	Disabled, Enabled
Snoop Latency Override	Auto	Disabled, Manual, Auto
Non Snoop Latency Override	Auto	Disabled, Manual, Auto
LTR Lock	Disabled	Disabled, Enabled
Peer Memory Write Enable	Disabled	Disabled, Enabled
▶ PCI Express Root Port 9		
PCI Express Root Port 9	Enabled	Disabled, Enabled
Connection Type	Slot	Built-in, Slot
ASPM	Auto	Disabled, L1, Auto
L1 Substates	L1.1 & L1.2	Disabled, L1.1, L1.1 & L1.2

Sub-screen	BIOS Defaults	Possible Setting
L1 Low	Enabled	Disabled, Enabled
ACS	Enabled	Disabled, Enabled
PTM	Enabled	Disabled, Enabled
DPC	Disabled	Disabled, Enabled
EDPC	Enabled	Disabled, Enabled
URR	Disabled	Disabled, Enabled
FER	Disabled	Disabled, Enabled
NFER	Disabled	Disabled, Enabled
CER	Disabled	Disabled, Enabled
SEFE	Disabled	Disabled, Enabled
SENF	Disabled	Disabled, Enabled
SECE	Disabled	Disabled, Enabled
PME SCI	Enabled	Disabled, Enabled
Hot Plug	Disabled	Disabled, Enabled
Advanced Error Reporting	Enabled	Disabled, Enabled
PCIe Speed	Auto	Auto, Gen1, Gen2, Gen3
Transmitter Half Swing	Disabled	Disabled, Enabled
Detect Timeout	0	0-65535
Extra Bus Reserved	0	0-7
Reserved Memory	10	1-20
Reserved I/O	4	4-20
PCH PCIe LTR Configuration		
LTR	Enabled	Disabled, Enabled
Snoop Latency Override	Auto	Disabled, Manual, Auto
Non Snoop Latency Override	Auto	Disabled, Manual, Auto
LTR Lock	Disabled	Disabled, Enabled
Peer Memory Write Enable	Disabled	Disabled, Enabled
▶ PCI Express Root Port 10		
PCI Express Root Port 10	Enabled	Disabled, Enabled
Connection Type	Slot	Built-in, Slot
ASPM	Auto	Disabled, L1, Auto
L1 Substates	L1.1 & L1.2	Disabled, L1.1, L1.1 & L1.2
L1 Low	Enabled	Disabled, Enabled

Sub-screen	BIOS Defaults	Possible Setting
ACS	Enabled	Disabled, Enabled
PTM	Enabled	Disabled, Enabled
DPC	Disabled	Disabled, Enabled
EDPC	Enabled	Disabled, Enabled
URR	Disabled	Disabled, Enabled
FER	Disabled	Disabled, Enabled
NFER	Disabled	Disabled, Enabled
CER	Disabled	Disabled, Enabled
SEFE	Disabled	Disabled, Enabled
SENF	Disabled	Disabled, Enabled
SECE	Disabled	Disabled, Enabled
PME SCI	Enabled	Disabled, Enabled
Hot Plug	Disabled	Disabled, Enabled
Advanced Error Reporting	Enabled	Disabled, Enabled
PCIe Speed	Auto	Auto, Gen1, Gen2, Gen3
Transmitter Half Swing	Disabled	Disabled, Enabled
Detect Timeout	0	0-65535
Extra Bus Reserved	0	0-7
Reserved Memory	10	1-20
Reserved I/O	4	4-20
PCH PCIe LTR Configuration		
LTR	Enabled	Disabled, Enabled
Snoop Latency Override	Auto	Disabled, Manual, Auto
Non Snoop Latency Override	Auto	Disabled, Manual, Auto
LTR Lock	Disabled	Disabled, Enabled
Peer Memory Write Enable	Disabled	Disabled, Enabled
PCI Express Root Port 11	Lane configured as USV/SATA/UFS	
PCI Express Root Port 12	Lane configured as USV/SATA/UFS	
▶ PCIe Clocks		
Clock0 assignment	Enabled	Platform-POR, Enabled, Disabled

Sub-screen	BIOS Defaults	Possible Setting
ClkReq for Clock0	Platform-POR	Platform-POR, Disabled
Clock1 assignment	Enabled	Platform-POR, Enabled, Disabled
ClkReq for Clock1	Platform-POR	Platform-POR, Disabled
Clock2 assignment	Enabled	Platform-POR, Enabled, Disabled
ClkReq for Clock2	Platform-POR	Platform-POR, Disabled
Clock3 assignment	Enabled	Platform-POR, Enabled, Disabled
ClkReq for Clock3	Platform-POR	Platform-POR, Disabled
Clock4 assignment	Enabled	Platform-POR, Enabled, Disabled
ClkReq for Clock4	Platform-POR	Platform-POR, Disabled
Clock5 assignment	Enabled	Platform-POR, Enabled, Disabled
ClkReq for Clock5	Platform-POR	Platform-POR, Disabled
Clock6 assignment	Enabled	Platform-POR, Enabled, Disabled
ClkReq for Clock6	Platform-POR	Platform-POR, Disabled
Clock7 assignment	Enabled	Platform-POR, Enabled, Disabled
ClkReq for Clock7	Platform-POR	Platform-POR, Disabled
Clock8 assignment	Enabled	Platform-POR, Enabled, Disabled
ClkReq for Clock8	Platform-POR	Platform-POR, Disabled
Clock9 assignment	Enabled	Platform-POR, Enabled, Disabled
ClkReq for Clock9	Platform-POR	Platform-POR, Disabled
► SATA Configuration		
SATA Controller(s)	Enabled	Disabled, Enabled
SATA Mode Selection	AHCI	AHCI
SATA Test Mode	Disabled	Disabled, Enabled
Aggressive LPM Support	Enabled	Disabled, Enabled
Serial ATA Port 0	Empty	
Software Preserve	Unknown	
Port 0	Enabled	Disabled, Enabled
Hot Plug	Disabled	Disabled, Enabled
Configure as eSATA	Hot Plug supported	
External	Disabled	Disabled, Enabled
Spin Up Device	Disabled	Disabled, Enabled

Sub-screen	BIOS Defaults	Possible Setting
SATA Device Type	Hard Disk Drive	Hard Disk Drive, Solid State Drive
Topology	Unknown	Unknown, ISATA, Direct connect, Flex, M2
SATA Port 0 DevSlp	Disabled	Disabled, Enabled
DITO Configuration	Disabled	Disabled, Enabled
DITO Value	625	
DM Value	15	
Serial ATA Port 1	Empty	
Software Preserve	Unknown	
Port 1	Enabled	Disabled, Enabled
Hot Plug	Disabled	Disabled, Enabled
Configure as eSATA	Hot Plug supported	
External	Disabled	Disabled, Enabled
Spin Up Device	Disabled	Disabled, Enabled
SATA Device Type	Hard Disk Drive	Hard Disk Drive, Solid State Drive
Topology	Unknown	Unknown, ISATA, Direct connect, Flex, M2
SATA Port 1 DevSlp	Disabled	Disabled, Enabled
DITO Configuration	Disabled	Disabled, Enabled
DITO Value	625	
DM Value	15	
Serial ATA Port 2	Empty	
Software Preserve	Unknown	
Port 2	Enabled	Disabled, Enabled
Hot Plug	Disabled	Disabled, Enabled
Configure as eSATA	Hot Plug supported	
External	Disabled	Disabled, Enabled
Spin Up Device	Disabled	Disabled, Enabled
SATA Device Type	Hard Disk Drive	Hard Disk Drive, Solid State Drive
Topology	Unknown	Unknown, ISATA, Direct connect, Flex, M2
SATA Port 2 DevSlp	Disabled	Disabled, Enabled
DITO Configuration	Disabled	Disabled, Enabled
DITO Value	625	
DM Value	15	

Sub-screen	BIOS Defaults	Possible Setting
▶ USB Configuration		
xDCI Support	Disabled	Disabled, Enabled
USB2 PHY Sus Well Power Gating	Enabled	Disabled, Enabled
USB PDO Programming	Enabled	Disabled, Enabled
USB Overcurrent	Enabled	Disabled, Enabled
USB Overcurrent Lock	Enabled	Disabled, Enabled
USB Audio Offload	Enabled	Disabled, Enabled
USB Enable HSII on xHCI	Enabled	Disabled, Enabled
USB3.1 Portx Speed Selection	0	0-15
USB Port Disable Override	Disable	Disable, Select Per-Pin
▶ TSN GBE Configuration		
PCH LAN Controller	No GbE Region	
Port 80h Redirection	LPC Bus	LPC Bus, PCIE Bus
Enhance Port 80h LPC Decoding	Enabled	Disabled, Enabled
PCH LAN Controller	Disabled	

### 13.7. Security Setup Menu

Figure 25: Security Setup Menu Example

Aptio Setup - AMI					
Main	Advanced	Power	Boot	Security	Save & Exit
Password Description  If ONLY the Administrator’s password is set, then this only limits access to Setup and is only asked for when entering Setup If ONLY the User’s password is set, then this is a power on password and must be entered to boot or enter Setup. In Setup the User will have Administrator rights. The password length must be in the following range: Minimum Length 3 Maximum length 20					
Administrator Password User Password  ► Secure Boot				→ ←: Select Screen  ↑ ↓: Select Item Enter: Select +/-: Change Opt. F1: General Help F2: Previous Values F3: Optimized Defaults F4: Save & Reset ESC: Exit	

The following table gives more information about important setup options within the Security Menu.

Table 43: Security Setup Menu Sub-screens Example

Sub-screen	BIOS Default	Possible Settings
System Mode	Setup	
Secure Boot	Disabled	Disabled, Enabled
	Not Active	
Secure Boot Mode	Standard	Standard, Custom
► Restore Factory Keys		
► Reset to Setup Mode		
► Key Management		

Sub-screen	BIOS Default	Possible Settings
Vendor Keys	Valid	
Factory Key Provision	Disabled	Disabled, Enabled
▶ Restore Factory Keys		
▶ Reset to Setup Mode		
▶ Enroll Efi Image		
▶ Export Secure Boot variables		
Secure Boot variable		
▶ Platform Key (PK)		
▶ Key Exchange Keys		
▶ Authorized Signatures		
▶ Forbidden Signatures		
▶ Authorized TimeStamps		
▶ OsRecovery Signatures		



UEFI only! No legacy support and no Master Boot Record (MBR) installation.

## 13.8. Boot Setup Menu

Figure 26: Boot Setup Menu Example

Aptio Setup - AMI					
Main	Advanced	Power	Boot	Security	Save & Exit
Boot Configuration					
Setup Prompt Timeout		[1]			
Bootup NumLock State		[Off]			
Quiet Boot		[Disabled]			
Fixed Boot order		[Enabled]			
Boot Option Priorities					
Boot Option #1		[xxxxx]		→ ←: Select Screen ↑ ↓: Select Item Enter: Select +/-: Change Opt. F1: General Help F2: Previous Values F3: Optimized Defaults F4: Save & Reset ESC: Exit	
▶ UEFI NVME Drive BBS Priorities					
▶ UEFI Application Boot Priorities					

The following table gives more information about important setup options within the Boot menu.

Table 44: Boot Setup Menu Sub-screens Example

Sub-screen	BIOS Default	Possible Settings
Boot Configuration		
Setup Prompt Timeout	1	1-65535 Displays number of seconds the firmware waits for setup activation key. (65535 (0xFFFF) means an indefinite wait)
Bootup NumLock State	Off	On, Off
Quiet Boot	Disable	Disabled, Enabled
Fixed Boot Order	Enabled	Disabled, Enabled
Boot Option Priorities		
Boot Option #1	XXXXXX	
▶ UEFI Hard Disk Drive BBS Priorities		
Boot Option #1	XXXXXX	
▶ UEFI Application Boot Priorities		
Boot Option #1	UEFI: Built-in EFI Shell	UEFI: Built-in EFI Shell, Disabled

## 13.9. Save and Exit Setup Menu

Figure 27: Save and Exit Setup Menu Example

Aptio Setup - AMI					
Main	Advanced	Power	Boot	Security	Save & Exit
Save Options					
Save Changes and Exit					
Discard Changes and Exit					
Save Changes and Reset					
Discard Changes and Reset					
Save Changes					
Discard Changes					
Default Options				→ ←: Select Screen	
Restore Defaults				↑ ↓: Select Item	
Save as User Default				Enter: Select	
Restore User Defaults				+/-: Change Opt.	
Boot Override				F1: General Help	
UEFI: Built-in EF Shell				F2: Previous Values	
XXXXX				F3: Optimized Defaults	
				F4: Save & Reset	
				ESC: Exit	

The following table gives more information about important setup options within the Save and Exit Menu.

Table 45: Save and Exit Setup Menu Sub-screens Example

Sub-screen	Description
Save Changes and Exit>	Exits system after saving changes
Discard Changes and Exit>	Exits system setup without saving changes
Save Changes and Reset>	Reset system after saving changes
Discard Changes and Reset>	Resets system setup without saving changes
Save Changes>	Saves changes made so far for any setup options
Discard Changes>	Discards changes made so far to the setup values and restore the previously saved values.
Restore Defaults>	Restores/loads standard default values for all setup options
Save as User Defaults>	Saves changes made so far as user defaults
Restore User Defaults>	Restores user defaults to all setup options
UEFI Built-in EFI shell>	Attempts to launch the built in EFI Shell

## 14/ Maintenance and Prevention

Maintenance or repair on the KBox A-151-RPL may only be carried out by skilled personnel authorized by Kontron. Kontron products require only minimum servicing and maintenance for problem-free operation.

Read and observe the warnings within this chapter and observe the safety instructions in Chapter 2/General Safety Instructions before opening the product to perform maintenance. Kontron recommends returning the product to Kontron, see Chapter 15.1: Returning Defective Merchandise.

---

### Handling and Operation

#### ⚠ CAUTION

Handling and operation of the product is permitted only for skilled personnel aware of the associated dangers within an access-controlled workplace that fulfills all necessary technical and environmental requirements.

---

### Switch Off Properly

#### ⚠ CAUTION

Before opening the product, the product must be switched off using the power button, and all peripheral devices disconnected. Disconnect the product by removing the power cable from the Power IN connector or the DC power supply.

---

### Hot Surface



Heatsinks can get very hot. To avoid burns and personal injury when handling the heatsink:

- › Do not touch while in operation
- › Allow to cool before handling
- › Wear protective gloves



### ESD Sensitive Device!

Follow the safety instructions for components that are sensitive to electrostatic discharge (ESD). Failure to observe this warning notice may result in damage to the product or/and internal components.

---

### Protection Label

#### NOTICE

The product is factory configured to meet customer requirements and then sealed with a protection label. Opening the product invalidates the warranty and may cause damage to internal components.

---

### Return to Kontron

#### NOTICE

Kontron recommends users to return the product to Kontron to avoid damage during maintenance. For more information, see Chapter 15.1: Returning Defective Merchandise.

---

## 14.1. Cleaning

The heatsink can get very hot. Take precautions before handling or touching the heatsink to clean the product. Kontron recommends cleaning the heatsink to improve the heatsink's heat dissipation to the ambient environment.



### Hot Surface

Heatsinks can get very hot. To avoid burns and personal injury when handling the heatsink:

- › Do not touch while in operation
- › Allow to cool before handling
- › Wear protective gloves

To clean the surface of the product, perform the following:

1. Close all applications. Shut down properly using the power button and disconnect the power cable from the Power IN connector or the DC power supply. Disconnect all peripherals.
2. Allow the product to cool before handling and do not touch the heatsink when the product is in operation.
3. Carefully remove dust using a clean, soft brush and if light soiling, clean the product with a dry cloth.
4. Remove stubborn dirt using mild detergent and a soft cloth.

## 14.2. Replacing the RTC Lithium Battery

An empty RTC lithium battery BIOS does not affect the BIOS settings. However, the system time and date are affected and must be reconfigured after replacing the battery. The RTC lithium battery BR2032 with cable must be replaced with an identical three Volt lithium battery or a Kontron recommended lithium battery, see Table 2: Accessories and Spare Parts

For replacement or installation, Kontron recommends returning the product to Kontron, see Chapter 15.1: Returning Defective Merchandise

### **CAUTION**

#### Danger of Explosion if the lithium battery is incorrectly placed!

- › Replace only with the same or equivalent type recommended by the manufacturer
- › Dispose of used batteries according to the manufacturer's instructions



When booting after replacing the RTC lithium battery, the boot time is longer, as the board performs several reboots before startup.



Do not dispose of lithium batteries in general trash collection. Dispose of the lithium battery according to the local regulations dealing with the disposal of these special materials, (e.g. to the collecting points for disposal of batteries).

**Figure 28: RTC Lithium Battery (default) and Automotive Lithium Battery Module (option)**

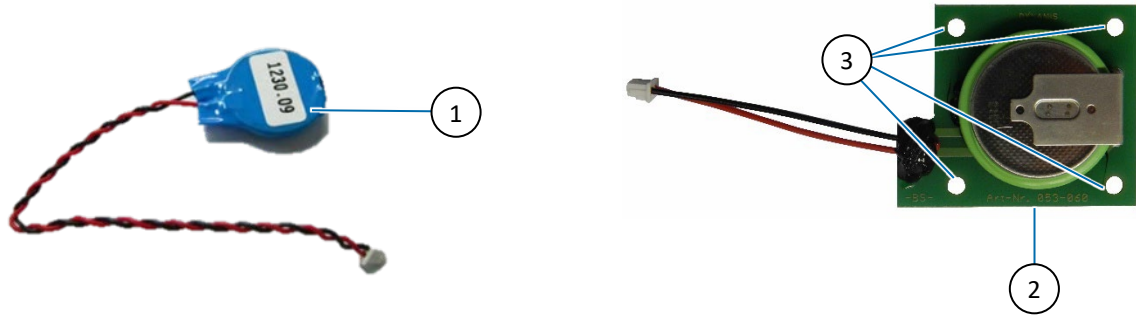

1 RTC lithium battery BR2032 with cable

2 Automotive lithium battery module BR2450 with cable

3 4x Screw openings.

To replace the RTC lithium battery (default or automotive option), perform the following:

1. Close all applications. Shut down properly using the power button and disconnect the power cable from the Power IN connector or the DC power supply. Disconnect all peripherals.
2. Allow the product to cool before handling and do not touch the heatsink until the heatsink has cooled.
3. Place the product on an ESD mat with the heatsink facing downwards.
4. Remove the two screws on the bottom side of the product. Retain the screws for later use.



5. Removed the screw on the right and left sides of the product. Retain the screws for later use.



6. If attached, remove the DIN Rail clamp. Then remove the three screws on the rear side of the product. Retain the screws for later use.



7. Lift the cover vertically upwards off the heatsink-front-panel-assembly, while taking care not to damage internal components or disconnect any internal cables. Place the cover on a soft surface to avoid scratching.



8. To replace the installed RTC lithium battery:
  - a. To replace the default RTC lithium battery, disconnect the lithium battery header from the internal RTC Power Input header. Note the polarity before disconnecting. Pull the lithium battery firmly to detach the lithium battery's adhesive pad from the internal connector housing. Insert the new RTC lithium battery's header into the RTC Power Input header. Ensure correct polarity. Attach the new lithium battery to the internal connector housing using a new adhesive pad.
  - b. To replace the optional automotive lithium battery module, disconnect the automotive lithium battery header from the battery extension cable. Note the polarity before disconnecting. Remove and retain the four screws fastening the automotive lithium battery module and lift the automotive lithium battery module out. Fasten the new automotive lithium battery module using the retained four screws. Insert the new automotive lithium battery module's cable header into the battery extension cable. Ensure correct polarity.
9. Close the product by proceeding in the reverse order (steps 7 to 4).

### 14.3. Inserting and Extracting a SIM Card

#### NOTICE

#### Switch off to Insert/Extract SIM

Only insert or extract the SIM cards if the product is switched off properly.



A SIM card is not part of the delivery and must be provided by the user, to support the required network.

To insert a SIM card into the SIM slot on the front panel, perform the following:

1. Close all applications. Shut down properly using the power button and disconnect the power cable from the Power IN connector or the DC power supply.
2. Allow the product to cool before handling or do not touch the heatsink.
3. Insert the SIM card with the terminal contacts facing forwards on the underside.
4. Push the SIM card carefully into the SIM slot until the card clicks acoustically.

To extract a SIM card from the SIM slot on the front panel, perform the following:

1. Close all applications. Shut down properly using the power button and disconnect the power cable from the Power IN connector or the DC power supply.

2. Allow the product to cool before handling or do not touch the heatsink.
3. Push the inserted SIM card slightly to release the card from the SIM slot.
4. Pull the SIM card carefully out of the slot.

## 15/ Technical Support

Should a problem occur, contact Kontron's Support Department:

- › Email: support@kontron.com
- › Phone: +49-821-4086-888

Make sure you have the following information available when you call:

- › Product ID Number (PN)
- › Serial Number (SN)



The serial number can be found on the product's type label.

---

Be ready to explain the nature of your problem to the service technician.

### 15.1. Returning Defective Merchandise

All equipment returned to Kontron must have a Return of Material Authorization (RMA) number assigned exclusively by Kontron. Kontron cannot be held responsible for any loss or damage caused to the equipment received without an RMA number. The buyer accepts responsibility for all freight charges for the return of goods to Kontron's designated facility. Kontron will pay the return freight charges back to the buyer's location in the event that the equipment is repaired or replaced within the stipulated warranty period. Follow these steps before returning any product to Kontron.

Follow these steps before returning any product to Kontron.

1. Visit the RMA Information website: <http://www.kontron.com/support-and-services/support/rma-information>.
2. Download the RMA Request sheet for Kontron Europe GmbH and fill out the form. Take care to include a short detailed description of the observed problem or failure and to include the product identification Information (Name of product, Product number and Serial number). If a delivery includes more than one product, fill out the above information in the RMA Request form for each product.
3. Send the completed RMA-Request form to the fax or email address given below at Kontron Europe GmbH. Kontron will provide an RMA-Number.
4. Kontron Europe GmbH  
RMA Support  
Phone: +49 (0) 821 4086-0  
Fax: +49 (0) 821 4086 111  
Email: service@kontron.com
5. The goods for repair must be packed properly for shipping, considering shock and ESD protection.



Goods returned to Kontron Europe GmbH in non-proper packaging will be considered as customer caused faults and cannot be accepted as warranty repairs.

---

6. Include the RMA-Number with the shipping paperwork and send the product to the delivery address provided in the RMA form or received from Kontron RMA Support.

## 16/ Storage and Transportation

### 16.1. Storage

If the product is not in use for an extended period of time, disconnect the product from the main power supply. If it is necessary to store the product, then repack the product as originally delivered to avoid damage. The storage facility must meet the product's environmental storage requirements as stated within this user guide. Kontron recommends keeping the original packaging material for future storage or warranty shipments.

### 16.2. Transportation

To ship the product, use the original packaging, designed to withstand impact and adequately protect the product. When packing or unpacking the product, always take shock and ESD protection into consideration and use an EOS/ESD safe working area.

## 17/ Warranty

Kontron defines product warranty in accordance with regional warranty definitions. Claims are at Kontron's discretion and limited to the defect being of a material nature. To find out more about the warranty conditions and the defined warranty period for your region, follow the steps below:

1. Visit Kontron's Term and Conditions webpage.

<http://www.kontron.com/terms-and-conditions>

2. Click on your region's General Terms and Conditions of Sale.

### 17.1. Limitation/Exemption from Warranty Obligation

In general, Kontron shall not be required to honor the warranty, even during the warranty period, and shall be exempted from the statutory accident liability obligations in the event of damage caused to the product due to failure to observe the following:

- › General safety instructions in this user guide.
- › Warning labels on the product and warning symbols within this user guide.
- › Information and hints within this user guide.

Additionally, alterations or modifications to the product that are not explicitly approved by Kontron, described in this user guide, or received from Kontron Support as a special handling instruction will void your warranty.

Due to their limited service life, parts that by their nature are subject to a particularly high degree of wear (wearing parts) are excluded from the warranty beyond that provided by law.

## 18/ Disposal

### 18.1. Disposal

Dispose of the product in accordance with country, state, or local regulations and requirements as part of your disposal and decommissioning policies or recycle the product or parts of the product for re-use after performing data sanitization to erase sensitive data stored on the product's memory devices.

When disposing of the product

- › Remove any product labels from the product that could indicate ownership and provide a clue to the type of data stored on the memory device.
- › Comply with your company's environmental requirements and the requirements of Waste Electrical and Electronic Equipment (WEEE) directive.
- › Use data sanitization guidelines to ensure that data sensitive to your business and/or confidential or proprietary data and software is removed from the product using a data sanitization method that stops the data from being retrieved or reconstructed.

### 18.2. WEEE Compliance

The Waste Electrical and Electronic Equipment (WEEE) Directive aims to:

- › Reduce waste arising from electrical and electronic equipment (EEE).
- › Make producers of EEE responsible for the environmental impact of their products, especially when the product becomes waste.
- › Encourage separate collection and subsequent treatment, reuse, recovery, recycling and sound environmental disposal of EEE.
- › Improve the environmental performance of all those involved during the lifecycle of EEE.



Environmental protection is a high priority with Kontron.  
Kontron follows the WEEE directive  
You are encouraged to return our products for proper disposal.

### 18.3. Data Sanitization

Data sanitization is the process of permanently erasing or destroying sensitive data on the product's memory devices to prevent unauthorized access to data sensitive to your business and/or confidential/proprietary data stored on the memory devices.

When designing a system, the user must plan for data sanitization and design in memory devices that are easier to sanitize, memory devices from manufacturers that provide an effective data erasure tool or a return to factory default command.

When performing data sanitization, the user must consider if the product's memory devices contain sensitive data and develop a data sanitization plan to erase all sensitive data in accordance with country, state, or local data sanitization regulations and requirements or as part of your disposal and decommissioning policies.



#### Data Sanitization

Users are responsible for erasing sensitive data on memory devices in accordance with country, state, or local data sanitization regulations and requirements, or as part of your disposal and decommissioning policies.

Kontron recommends performing data sanitization when reusing the product in a different user environment, sending the product in for repair, disposing of the product or decommissioning the product.

General guidelines when performing data sanitization on memory devices containing data sensitive to your business and/or confidential/proprietary data:

- › Before powering down, consider if power is required to perform data sanitization on the product’s memory devices.
- › When disconnected from the power source, dismantle all removable memory devices from the product and erase sensitive data.
- › Volatile memory devices only store data temporarily. Data on volatile memory can be erased easily by disconnecting the power/removing the battery for approximately 24 hours.
- › Non-volatile memory devices store data permanently and retain information when disconnected from power. Data on von-volatile memory must be actively erased using one of the following methods:
  - › Use an accredited third-party software tool that provides an audit trail, capable of performing a complete data clean including areas such as hidden data and bad blocks not accessed by general service-based utilities.
  - › Use the physical destruction methods on memory devices that cannot be securely software erased. The aim of the destruction is to break the silicon die within the chips package into two or more parts to prevent reading data from the die. Fragments should be no longer than 6 mm. If this service is performed by a third party obtain destruction certificates for confirmation.
  - › Use the manufacture’s data erasure tool for sanitization or return to factory default command (if provided by the manufacturer). The manufactures tools and commands have been designed to fulfil the data sanitization requirement of the manufacture’s specific memory device(s).
- › Always verify that all sensitive data has been effectively sanitized.



#### **Dismantle Removable Memory**

Dismantle all removable memory devices and erase sensitive data for reuse by using:

- › An accredited third-party software tool.
  - › Manufacture’s data erasure tool’ or ‘return to factory default command’. (if provided)
  - › If the removable memory is not for reuse, physically destruct the memory according to data sanitization guidelines.
- 



#### **Erase Data**

To ensure that forensic tools cannot be used to recover sensitive data:

- › Use an accredited third-party software tool, with an audit trail, capable of performing a complete data clean, including areas such as hidden data and bad blocks not accessed by general service-based utilities.
  - › Use the manufacture’s data erasure tool or return to factor default command designed to fulfil the data sanitization requirement of the manufacture’s specific memory device(s).
- 



#### **Physical Destruction**

When physically destructing the memory:

- › Follow proper safety protocols.
  - › Break the chip packaged silicon die into two or more parts, fragments  $\leq 6$  mm.
  - › Check both sides as memory devices may be positioned on the rear side.
  - › Use a third-party destruction company providing certificates for confirmation.
-

## 18.4. Statement of Memory Volatility

The KBox A-151-RPL's statement of memory volatility (Table 46) provides the user with a list of the product's memory devices and their volatility, to enable the user to develop a suitable data sanitization plan. This list may change over time as electronic devices become EOL and require a replacement device.

Note that not all memory devices may be part of your delivered product. Some memory devices are options chosen by the user. Users are responsible for considering the memory devices installed on the product and must take appropriate action to clear the memory if required.

Third-party devices such as M.2 modules installed on the product may include memory devices and should be removed by the user before disposing of the product. It is the responsibility of the user to observe that the third-party devices are removed according to the manufacturer's instructions.



In some cases, special tools and/or software are necessary to access the memory.



The Statement of Memory Volatility lists the known possible memory devices and due to configuration options may differ from your delivered product and memory sizes may change.

**Table 46: KBox A-151-RPL Statement of Memory Volatility Example**

Memory Type	Ref. # / Loc.	Memory Size <sup>[2]</sup>	Volatility	Retain Data when Power Off	Alterable in Field <sup>[1]</sup>	Battery Backed Up	Data Type	Write Protected	Emergency Erase	Process to Clear
DDR										
DDR5 SODIMM	SBC Board DIMM slot	Up to 48 GB	Volatile	No	Yes	No	User Data	No	No	NA
DDR5 SODIMM		Up to 48 GB	Volatile	No	Yes	No	User Data	No	No	NA
EC										
Embedded Controller MEC1521	SBC Board	Code Storage: 480 KB (Code + Data) Data RAM: 32 KB	Non-volatile (Code storage) Volatile (RAM)	Yes	Yes	No	Embedded controller config.	Yes	No	Perform EC FW update
CMOS-FLASH SPI MX25V16 35FM2I	SBC Board	16 Mbit	Non-volatile	Yes	Yes	No	EFI Boot	Yes	Yes	Perform BIOS recovery
LAN										
FLASH SPI W25Q16J VSSIQ	SBC Board	16 Mbit	Non-volatile	Yes	Yes	No	EFI Boot	Yes (SW)	No	Perform BIOS recovery
BIOS										
FLASH SPI W25Q256J VEIQ	SBC Board	256 Mbit	Non-volatile	Yes	Yes	No	EFI Boot	Yes (SW)	No	Perform BIOS recovery

Memory Type	Ref. # / Loc.	Memory Size <sup>[2]</sup>	Volatility	Retain Data when Power Off	Alterable in Field <sup>[1]</sup>	Battery Backed Up	Data Type	Write Protected	Emergency Erase	Process to Clear
EEPROM										
EEPROM AT24C32E-SSHM-T	SBC Board	32 Kbit	Non-volatile	Yes	Yes	No	Module ID Data	Yes	No	NA
LVDS										
EEPROM Chronitel CH9904	SBC Board	64 Kbit	Non-volatile	Yes	Yes	No	Module ID Data	Yes	No	NA
VCORE										
MP2964R	SBC Board	8 Kbit	Non-volatile	Yes	No	No	VR Config.	No	No	NA
TPM										
SLB 9672XU2.0	SBC Board	51 KByte	Non-volatile	Yes	Yes	No	User Data	Yes	No	Perform clear item under OS
M.2 Key M Socket										
M.2 Key M 2280 SSD <sup>[3]</sup>	SBC Board M.2 Key M socket	Up to 1 TByte	Non-volatile	Yes	Yes	No	Storage	No	No	Remove from board

<sup>[1]</sup> In some cases special tools and/or software are necessary to access the memory.

<sup>[2]</sup> Memory size may vary, as over time devices reach EOL or newer higher-density memory devices are introduced.

<sup>[3]</sup> This memory type is an option and may not be included in your configuration.

## 19/ Cyber Security

Cyber security is an important aspect to consider when installing, operating, maintaining and disposing of the product. This chapter provides cyber security guidelines for the user.



### Security White Paper

For cyber security guidelines to protect your Kontron product from potential cyber security threats, refer to Kontron's [Security White paper](#).

---



### Security Measures

Kontron is not aware of the final target end user environment in which the product operates. It is not possible for Kontron to provide precise instructions for your cyber security measures. Kontron strives to provide hints for considerations for your threat analysis and to point out particular security mechanisms implemented in Kontron products.

---

### 19.1. Security Defense Strategy

When developing your security defense strategy consider implementing the following guidelines to help you effectively secure the product:

- › Policies and procedures developed in association with the product's/end environment's security.
- › Instructions and recommendations for periodic security maintenance activities and reporting product security incidents.
- › Security network controls/setting such as firewall rules.
- › Third party software tools that further protect the product.
- › Authentication to access the product, limit user privileges and managing user accounts.
- › Data encryption.
- › Reduced number of potential security entry points.
- › BIOS/OS and security updates that do not compromise the product's operation or defense in depth strategy.
- › User accounts with length and complexity requirements.
- › Supplied default passwords are changed.
- › Limited network access (IP address range).
- › Installation of anti-virus and malware software.
- › Network access requirements such as VPN.

## Appendix: List of Acronyms

<b>AC</b>	Alternating Current
<b>BIOS</b>	Basic Input Output System
<b>CAN</b>	Controller Area Network
<b>CE</b>	Conformité Européenne
<b>COM</b>	Communication port
<b>DC</b>	Direct Current
<b>DOC</b>	Declaration of Conformity
<b>DP</b>	DisplayPort
<b>EMC</b>	ElectroMagnetic compatibility
<b>ESD</b>	ElectroStatic Discharge
<b>FCC</b>	Federal Communications Commission
<b>GB</b>	Ground Benign
<b>GbE</b>	Giga Bit Ethernet
<b>GPIO</b>	General Purpose Input Output
<b>HD</b>	High Definition
<b>HDMI</b>	High Definition Multimedia Interface
<b>IEC</b>	International Electrotechnical Commission
<b>IOT</b>	Internet of Things
<b>IP</b>	International Protection
<b>LAN</b>	Local Area Network
<b>LED</b>	Light Emitting Diode
<b>LPS</b>	Limited Power Source
<b>LTE</b>	Long-Term Evolution
<b>MBR</b>	Master Boot Record
<b>MDI</b>	Media Dependent Interface
<b>MTBF</b>	Mean Time Before Failure
<b>NC</b>	Not Connected
<b>PS</b>	Power Source
<b>PSU</b>	Power Supply Unit
<b>RED</b>	Radio Equipment Directive
<b>RMA</b>	Return of Material Authorization
<b>RoHS</b>	Restriction of Hazardous Substances
<b>RP_SMA</b>	Reverse Polarity Sub Miniture version A
<b>RTC</b>	Real Time Clock
<b>RX</b>	Receive
<b>SD card</b>	Secure Digital Card
<b>SIM</b>	Subscriber Identity Module
<b>SMA</b>	Sub Miniture version A

<b>TDP</b>	Thermal Design Power
<b>TPM</b>	Trusted Platform Module
<b>TX</b>	Transmit
<b>UEFI</b>	Unified Extensible Firmware Interface
<b>UL</b>	Underwriters Laboratories
<b>USB</b>	Universal Serial Bus
<b>WDT</b>	WatchDog Timer



## About Kontron

Kontron is a global leader in IoT/Embedded Computing Technology (ECT) and offers individual solutions in the areas of Internet of Things (IoT) and Industry 4.0 through a combined portfolio of hardware, software and services. With its standard and customized products based on highly reliable state-of-the-art technologies, Kontron provides secure and innovative applications for a wide variety of industries. As a result, customers benefit from accelerated time-to-market, lower total cost of ownership, extended product lifecycles and the best fully integrated applications.

For more information, please visit: [www.kontron.com](http://www.kontron.com)

## Global Headquarters

Kontron Europe GmbH

Gutenbergstraße 2  
85737 Ismaning, Germany  
Tel.: +49 8214 4086-0  
[info@kontron.com](mailto:info@kontron.com)

[www.kontron.de](http://www.kontron.de)

