



# KBox F-210 Series

Doc. User Guide, Rev. 1.1

Doc. ID: [To be Determined]

This page has been intentionally left blank

 KBOX F-210 SERIES - USER GUIDE

## Disclaimer

Kontron would like to point out that the information contained in this user guide may be subject to alteration, particularly as a result of the constant upgrading of Kontron products. This document does not entail any guarantee on the part of Kontron with respect to technical processes described in the user guide or any product characteristics set out in the user guide. Kontron assumes no responsibility or liability for the use of the described product(s), conveys no license or title under any patent, copyright or mask work rights to these products and makes no representations or warranties that these products are free from patent, copyright or mask work right infringement unless otherwise specified. Applications that are described in this user guide are for illustration purposes only. Kontron makes no representation or warranty that such application will be suitable for the specified use without further testing or modification. Kontron expressly informs the user that this user guide only contains a general description of processes and instructions which may not be applicable in every individual case. In cases of doubt, please contact Kontron.

This user guide is protected by copyright. All rights are reserved by Kontron. No part of this document may be reproduced, transmitted, transcribed, stored in a retrieval system, or translated into any language or computer language, in any form or by any means (electronic, mechanical, photocopying, recording, or otherwise), without the express written permission of Kontron. Kontron points out that the information contained in this user guide is constantly being updated in line with the technical alterations and improvements made by Kontron to the products and thus this user guide only reflects the technical status of the products by Kontron at the time of publishing.

Brand and product names are trademarks or registered trademarks of their respective owners.

©2020 by Kontron AG

Kontron AG

Lise-Meitner-Str. 3-5  
86156 Augsburg  
Germany  
[www.kontron.com](http://www.kontron.com)

## High Risk Applications Hazard Notice

**THIS DEVICE AND ASSOCIATED SOFTWARE ARE NOT DESIGNED, MANUFACTURED OR INTENDED FOR USE OR RESALE FOR THE OPERATION OF NUCLEAR FACILITIES, THE NAVIGATION, CONTROL OR COMMUNICATION SYSTEMS FOR AIRCRAFT OR OTHER TRANSPORTATION, AIR TRAFFIC CONTROL, LIFE SUPPORT OR LIFE SUSTAINING APPLICATIONS, WEAPONS SYSTEMS, OR ANY OTHER APPLICATION IN A HAZARDOUS ENVIRONMENT, OR REQUIRING FAIL-SAFE PERFORMANCE, OR IN WHICH THE FAILURE OF PRODUCTS COULD LEAD DIRECTLY TO DEATH, PERSONAL INJURY, OR SEVERE PHYSICAL OR ENVIRONMENTAL DAMAGE (COLLECTIVELY, "HIGH RISK APPLICATIONS").**

You understand and agree that your use of Kontron devices as a component in High Risk Applications is entirely at your risk. To minimize the risks associated with your products and applications, you should provide adequate design and operating safeguards. You are solely responsible for compliance with all legal, regulatory, safety, and security related requirements concerning your products. You are responsible to ensure that your systems (and any Kontron hardware or software components incorporated in your systems) meet all applicable requirements. Unless otherwise stated in the product documentation, the Kontron device is not provided with error-tolerance capabilities and cannot therefore be deemed as being engineered, manufactured or setup to be compliant for implementation or for resale as device in High Risk Applications. All application and safety related information in this document (including application descriptions, suggested safety measures, suggested Kontron products, and other materials) is provided for reference only.

## Revision History

Revision	Brief Description of Changes	Date of Issue
1.0	Initial Issue	2019-Jul-31
1.1	Template update	2020-Jul-09

## Terms and Conditions

Kontron warrants products in accordance with defined regional warranty periods. For more information about warranty compliance and conformity, and the warranty period in your region, visit <http://www.kontron.com/terms-and-conditions>.

Kontron sells products worldwide and declares regional General Terms & Conditions of Sale, and Purchase Order Terms & Conditions. Visit <http://www.kontron.com/terms-and-conditions>.

For contact information, refer to the corporate offices contact information on the last page of this user guide or visit our website [CONTACT US](#).

## Customer Support

Find Kontron contacts by visiting: <http://www.kontron.com/support>.

## Customer Service

As a trusted technology innovator and global solutions provider, Kontron extends its embedded market strengths into a services portfolio allowing companies to break the barriers of traditional product lifecycles. Proven product expertise coupled with collaborative and highly-experienced support enables Kontron to provide exceptional peace of mind to build and maintain successful products.

For more details on Kontron's service offerings such as: enhanced repair services, extended warranty, Kontron training academy, and more visit <http://www.kontron.com/support-and-services/services>.

## Customer Comments

If you have any difficulties using this user guide, discover an error, or just want to provide some feedback, contact [Kontron support](#). Detail any errors you find. We will correct the errors or problems as soon as possible and post the revised user guide on our website.

## Symbols

The following symbols may be used in this user guide

### **⚠ DANGER**

DANGER indicates a hazardous situation which, if not avoided, will result in death or serious injury.

### **⚠ WARNING**

WARNING indicates a hazardous situation which, if not avoided, could result in death or serious injury.

### **NOTICE**

NOTICE indicates a property damage message.

### **⚠ CAUTION**

CAUTION indicates a hazardous situation which, if not avoided, may result in minor or moderate injury.



Electric Shock!

This symbol and title warn of hazards due to electrical shocks (> 60 V) when touching products or parts of products. Failure to observe the precautions indicated and/or prescribed by the law may endanger your life/health and/or result in damage to your material.



ESD Sensitive Device!

This symbol and title inform that the electronic boards and their components are sensitive to static electricity. Care must therefore be taken during all handling operations and inspections of this product in order to ensure product integrity at all times.



HOT Surface!

Do NOT touch! Allow to cool before servicing.



Laser!

This symbol inform of the risk of exposure to laser beam and light emitting devices (LEDs) from an electrical device. Eye protection per manufacturer notice shall review before servicing.



This symbol indicates general information about the product and the user guide.

This symbol also indicates detail information about the specific product configuration.



This symbol precedes helpful hints and tips for daily use.

## For Your Safety

Your new Kontron product was developed and tested carefully to provide all features necessary to ensure its compliance with electrical safety requirements. It was also designed for a long fault-free life. However, the life expectancy of your product can be drastically reduced by improper treatment during unpacking and installation. Therefore, in the interest of your own safety and of the correct operation of your new Kontron product, you are requested to conform with the following guidelines.

### High Voltage Safety Instructions

As a precaution and in case of danger, the power connector must be easily accessible. The power connector is the product's main disconnect device.

#### **CAUTION**

##### Warning

All operations on this product must be carried out by sufficiently skilled personnel only.

#### **CAUTION**



##### Electric Shock!

Before installing a non hot-swappable Kontron product into a system always ensure that your mains power is switched off. This also applies to the installation of piggybacks. Serious electrical shock hazards can exist during all installation, repair, and maintenance operations on this product. Therefore, always unplug the power cable and any other cables which provide external voltages before performing any work on this product.

Earth ground connection to vehicle's chassis or a central grounding point shall remain connected. The earth ground cable shall be the last cable to be disconnected or the first cable to be connected when performing installation or removal procedures on this product.

### Special Handling and Unpacking Instruction

#### **NOTICE**



##### ESD Sensitive Device!

Electronic boards and their components are sensitive to static electricity. Therefore, care must be taken during all handling operations and inspections of this product, in order to ensure product integrity at all times.

Do not handle this product out of its protective enclosure while it is not used for operational purposes unless it is otherwise protected.

Whenever possible, unpack or pack this product only at EOS/ESD safe work stations. Where a safe work station is not guaranteed, it is important for the user to be electrically discharged before touching the product with his/her hands or tools. This is most easily done by touching a metal part of your system housing.

It is particularly important to observe standard anti-static precautions when changing piggybacks, ROM devices, jumper settings etc. If the product contains batteries for RTC or memory backup, ensure that the product is not placed on conductive surfaces, including anti-static plastics or sponges. They can cause short circuits and damage the batteries or conductive circuits on the product.

## Lithium Battery Precautions

If your product is equipped with a lithium battery, take the following precautions when replacing the battery.

### **⚠ CAUTION**

**Danger of explosion if the battery is replaced incorrectly.**

- ▶ Replace only with same or equivalent battery type recommended by the manufacturer.
- ▶ Dispose of used batteries according to the manufacturer's instructions.

## General Instructions on Usage

In order to maintain Kontron's product warranty, this product must not be altered or modified in any way. Changes or modifications to the product, that are not explicitly approved by Kontron and described in this user guide or received from Kontron Support as a special handling instruction, will void your warranty.

This product should only be installed in or connected to systems that fulfill all necessary technical and specific environmental requirements. This also applies to the operational temperature range of the specific board version that must not be exceeded. If batteries are present, their temperature restrictions must be taken into account.

In performing all necessary installation and application operations, only follow the instructions supplied by the present user guide.

Keep all the original packaging material for future storage or warranty shipments. If it is necessary to store or ship the product then re-pack it in the same manner as it was delivered.

Special care is necessary when handling or unpacking the product. See Special Handling and Unpacking Instruction.

## Quality and Environmental Management

Kontron aims to deliver reliable high-end products designed and built for quality, and aims to complying with environmental laws, regulations, and other environmentally oriented requirements. For more information regarding Kontron's quality and environmental responsibilities, visit <http://www.kontron.com/about-kontron/corporate-responsibility/quality-management>.

## Disposal and Recycling

Kontron's products are manufactured to satisfy environmental protection requirements where possible. Many of the components used are capable of being recycled. Final disposal of this product after its service life must be accomplished in accordance with applicable country, state, or local laws or regulations.

## WEEE Compliance

The Waste Electrical and Electronic Equipment (WEEE) Directive aims to:

- ▶ Reduce waste arising from electrical and electronic equipment (EEE)
- ▶ Make producers of EEE responsible for the environmental impact of their products, especially when the product become waste
- ▶ Encourage separate collection and subsequent treatment, reuse, recovery, recycling and sound environmental disposal of EEE
- ▶ Improve the environmental performance of all those involved during the lifecycle of EEE



**Environmental protection is a high priority with Kontron.**

**Kontron follows the WEEE directive**

**You are encouraged to return our products for proper disposal.**

# Table of Contents

Symbols.....	6
<b>For Your Safety</b> .....	<b>7</b>
High Voltage Safety Instructions .....	7
Special Handling and Unpacking Instruction .....	7
Lithium Battery Precautions.....	8
<b>General Instructions on Usage</b> .....	<b>8</b>
<b>Quality and Environmental Management</b> .....	<b>8</b>
Disposal and Recycling.....	8
WEEE Compliance.....	8
<b>Table of Contents</b> .....	<b>9</b>
<b>List of Tables</b> .....	<b>11</b>
<b>List of Figures</b> .....	<b>11</b>
<b>1/ General Safety Instructions for IT Equipment</b> .....	<b>13</b>
1.1. Electrostatic Discharge (ESD).....	15
1.1.1. Grounding Methods .....	15
1.2. Lithium Battery Replacement .....	15
<b>2/ Electromagnetic Compatibility</b> .....	<b>17</b>
2.1. Electromagnetic Compatibility (EU).....	17
2.2. FCC Statement (USA).....	17
2.3. EMC Compliance (Canada) .....	17
<b>3/ Shipment and Unpacking</b> .....	<b>18</b>
3.1. Unpacking .....	18
3.2. Scope of Delivery .....	18
3.2.1. Standard .....	18
3.2.2. Optional Parts .....	18
<b>4/ System Overview</b> .....	<b>19</b>
4.1. System Expansion Capabilities .....	21
4.1.1. System Expansion via SATA Interface.....	21
4.1.2. System Expansion via mPCIe / mSATA Card Interface .....	21
4.1.3. System Expansion via Mini SIM Socket .....	21
4.2. Front I/O Panel.....	22
4.2.1. Power Button with LED.....	22
4.2.2. Storage LED .....	23
4.2.3. Wireless LED.....	23
4.2.4. Line-Out .....	23
4.2.5. Mic-In.....	23
4.2.6. Line-In.....	23
4.2.7. S/PDIF.....	23
4.2.8. USB 3.0 .....	23
4.2.9. USB 2.0 .....	24
4.2.10. Reset Button.....	24
4.2.11. WWAN Antenna Port .....	24
4.3. Rear I/O Panel .....	25
4.3.1. DC-In (Lockable DC Jack).....	25
4.3.2. DP .....	25
4.3.3. HDMI 2.0.....	25

4.3.4. GbE.....	25
4.3.5. RS232/422/485.....	26
4.3.6. WLAN Antenna Port.....	26
4.4. Internal View.....	27
4.4.1. DDR4 SO-DIMM Memory Socket.....	28
4.4.2. SATA Power / Data Connector.....	28
4.4.3. Full-sized mPCIe (mPCIe / mSATA) Socket.....	28
4.4.4. Half-sized mPCIe (mPCIe / mSATA) Socket.....	28
4.4.5. Mini SIM Card Socket.....	29
4.4.6. mPCIe / mSATA Selection Switch.....	29
<b>5/ Accessing Internal Components.....</b>	<b>30</b>
5.1. Opening and Closing the KBox F-210 Series.....	31
5.1.1. Installing an HDD / SSD.....	34
5.1.2. Installing an mSATA SSD or an mPCIe expansion card.....	34
5.1.3. Installing the Mini SIM card.....	35
<b>6/ Thermal Considerations.....</b>	<b>36</b>
6.1. Available Processors.....	36
6.2. Convection Cooling.....	36
6.3. System Clearance.....	36
6.4. Maximum Temperatures.....	36
6.5. Third Party Components.....	36
<b>7/ Installation Instructions.....</b>	<b>37</b>
7.1. System Mounting.....	38
7.1.1. System Mounting by Use of the VESA / Keyhole Mounting Bracket.....	38
7.1.2. System Mounting by Use of the Stand Bracket Pair.....	41
7.2. DC Power Connection.....	43
<b>8/ Starting Up.....</b>	<b>44</b>
8.1. Connecting to DC Power Supply.....	44
8.2. Operating System and Hardware Component Drivers.....	45
<b>9/ Maintenance and Cleaning.....</b>	<b>46</b>
<b>10/ Technical Specifications.....</b>	<b>47</b>
10.1. Mechanical Specifications.....	48
10.1.1. Mechanical Drawing.....	48
10.2. Environmental Conditions.....	49
10.3. Standards and Certifications.....	49
<b>11/ Standard Interfaces – Pin Assignments.....</b>	<b>50</b>
11.1.1. 19 V DC Power Input.....	50
11.1.2. Ethernet Connectors.....	50
11.1.3. USB 3.0 Port.....	50
11.1.4. USB 2.0 Port.....	51
11.1.5. DP Connector.....	51
11.1.6. HDMI Connector.....	52
11.1.7. RS232/422/485 Serial Port.....	52
11.1.8. Line-In Connector.....	53
11.1.9. Line-Out Connector.....	53
11.1.10. Mic-In Connector.....	53
<b>12/ uEFI BIOS.....</b>	<b>54</b>
12.1. Starting the uEFI BIOS.....	54
12.2. Setup Menus.....	55

12.2.1. Main Setup Menu .....	55
12.2.2. Advanced Setup Menu .....	57
12.2.3. Power Setup Menu.....	66
12.2.4. Security Setup Menu .....	68
12.2.4.1. Remember the password .....	69
12.2.5. Boot Setup Menu .....	70
12.2.6. Save & Exit Setup Menu .....	71
<b>Appendix A: List of Acronyms.....</b>	<b>72</b>
About Kontron .....	73

## List of Tables

Table 1: Power LED Status .....	23
Table 2: Switch Assignment SW2 .....	29
Table 3: Technical Specifications .....	47
Table 4: Mechanical Specifications .....	48
Table 5: Environmental Conditions.....	49
Table 6: Standards and Certifications .....	49
Table 7: 19 V DC Power Input (see Figure 3, pos.1).....	50
Table 8: Ethernet Connector (see Figure 3, pos. 4).....	50
Table 9: USB 3.0 Port (see Figure 1, pos. 8 & Figure 2, pos. 8).....	50
Table 10: USB 2.0 Port (see Figure 2, pos. 9) .....	51
Table 11: DP Connector (see Figure 3, pos. 2).....	51
Table 12: HDMI Connector (see Figure 3, pos. 3).....	52
Table 13: RS232/422/485 Serial Port (see Figure 3, pos. 5).....	52
Table 14: Line-In Connector (see Figure 1, pos. 6 & Figure 2, pos. 6) .....	53
Table 15: Line-Out Connector (see Figure 1, pos. 4 & Figure 2, pos. 4).....	53
Table 16: Mic-In Connector (see Figure 1, pos. 5 & Figure 2, pos. 5).....	53
Table 17: Navigation Hot Keys Available in the Legend Bar.....	54
Table 18: Main Setup Menu Sub-Screens and Functions.....	55
Table 19: List of Acronyms.....	72

## List of Figures

Figure 1: Front I/O Panel (Model with Q170 chipset) .....	22
Figure 2: Front I/O Panel (Model with H110 chipset) .....	22
Figure 3: Rear I/O Panel.....	25
Figure 4: Ethernet LED Status .....	25
Figure 5: Internal view (from bottom side).....	27
Figure 6: Internal view (from top side).....	28
Figure 7: mPCIe / mSATA Selection Switch (SW2).....	29
Figure 8: Descrewing the access cover of the KBox F-210 Series .....	31
Figure 9: Descrewing two chassis halves of the KBox F-210 Series .....	32
Figure 10: Disengaging the chassis of the KBox F-210 Series .....	32
Figure 11: Descrewing the baseboard of the KBox F-210 Series .....	33
Figure 12: Fixing holes to screw or descrew the HDD / SSD .....	33
Figure 13: Installing the Mini SIM card.....	35
Figure 14: VESA / keyhole mounting bracket .....	38
Figure 15: Hole patterns of VESA / keyhole mounting bracket for KBox F-210 Series.....	38
Figure 16: Securing the mounting bracket.....	39
Figure 17: Placing the KBox F-210 Series onto the mounting bracket.....	39
Figure 18: Securing the KBox F-210 Series and the mounting bracket together .....	40
Figure 19: Stand bracket pair .....	41
Figure 20: Securing the stand bracket pair to the KBox F-210 Series.....	41

Figure 21: Securing the KBox F-210 Series on the rack tray shelf .....	41
Figure 22: Mechanical Drawing .....	48
Figure 23: BIOS Main Menu Screen System Data and Time .....	56
Figure 24: BIOS Advanced Menu.....	57
Figure 25: BIOS Advanced Menu - Display Configuration .....	58
Figure 26: BIOS Advanced Menu - Super IO Configuration .....	59
Figure 27: BIOS Advanced Menu - Super IO Configuration - Serial Port 1 Configuration.....	59
Figure 28: BIOS Advanced Menu - CPU Chipset Configuration.....	61
Figure 29: BIOS Advanced Menu - SATA Configuration .....	62
Figure 30: BIOS Advanced Menu - USB Configuration.....	63
Figure 31: BIOS Advanced Menu - TPM Configuration.....	64
Figure 32: BIOS Advanced Menu - H/W Monitor.....	65
Figure 33: BIOS Power Setup Menu .....	66
Figure 34: BIOS Power Setup Menu - WatchDog Timer Configuration.....	67
Figure 35: BIOS Security Setup Menu.....	68
Figure 36: BIOS Boot Setup Menu .....	70
Figure 37: BIOS Boot Setup Menu.....	71

# 1/ General Safety Instructions for IT Equipment

## **⚠ WARNING**

Please read this chapter carefully and take careful note of the instructions, which have been compiled for your safety and to ensure to apply in accordance with intended regulations. If the following general safety instructions are not observed, it could lead to injuries to the operator and/or damage of the product; in cases of nonobservance of the instructions Kontron is exempt from accident liability, this also applies during the warranty period.

The product has been built and tested according to the basic safety requirements for low voltage (LVD) applications and has left the manufacturer in safety-related, flawless condition. To maintain this condition and also to ensure safe operation, the operator must not only observe the correct operating conditions for the product but also the following general safety instructions:

- ▶ The product must be used as specified in the product documentation, in which the instructions for safety for the product and for the operator are described. These contain guidelines for setting up, installation and assembly, maintenance, transport or storage.
- ▶ The on-site electrical installation must meet the requirements of the country's specific local regulations.
- ▶ If a power cable comes with the product, only this cable should be used. Do not use an extension cable to connect the product.
- ▶ To guarantee that sufficient air circulation is available to cool the product, please ensure that the ventilation openings are not covered or blocked. If an air filter is provided, this should be cleaned regularly. Do not place the system close to heat sources or damp places. Make sure the system is well ventilated.
- ▶ Only devices or parts which fulfill the requirements of SELV circuits (Safety Extra Low Voltage) as stipulated by IEC 60950-1 may be connected to the available interfaces.
- ▶ Before opening the device, make sure that the device is disconnected from the mains.
- ▶ Switching off the device by its power button does not disconnect it from the mains. Complete disconnection is only possible if the power cable is removed from the wall plug or from the device. Ensure that there is free and easy access to enable disconnection.
- ▶ The device may only be opened for the insertion or removal of add-on cards (depending on the configuration of the system). This may only be carried out by qualified operators.
- ▶ If extensions are being carried out, the following must be observed:
  - ▶ All effective legal regulations and all technical data are adhered to.
  - ▶ The power consumption of any add-on card does not exceed the specified limitations.
  - ▶ The current consumption of the system does not exceed the value stated on the product label.
- ▶ Only original accessories that have been approved by Kontron can be used.
- ▶ Please note: safe operation is no longer possible when any of the following applies:
  - ▶ The device has visible damages.
  - ▶ The device is no longer functioning.

In this case the device must be switched off and it must be ensured that the device can no longer be operated.

**Additional safety instructions for DC power supply circuits**

- ▶ To guarantee safe operation of devices with DC power supply voltages larger than 60 volts DC or a power consumption larger than 240 VA, please observe that:
  - ▶ the device is set up, installed and operated in a room or enclosure marked with "RESTRICTED ACCESS", if there are no safety messages on product as safety signs and labels on the device itself.
  - ▶ no cables or parts without insulation in electrical circuits with dangerous voltage or power should be touched directly or indirectly
  - ▶ a reliable protective earthing connection is provided
  - ▶ a suitable, easily accessible disconnecting device is used in the application (e.g. overcurrent protective device), if the device itself is not disconnectable
  - ▶ a disconnect device, if provided in or as part of the equipment, shall disconnect both poles simultaneously
  - ▶ interconnecting power circuits of different devices cause no electrical hazards
- ▶ A sufficient dimensioning of the power cable wires must be selected – according to the maximum electrical specifications on the product label – as stipulated by EN60950-1 or VDE0100 or EN60204 or UL508 regulations.
- ▶ The devices do not generally fulfill the requirements for "centralized DC power systems" (UL 60950-1, Annex NAB; D2) and therefore may not be connected to such devices!

## 1.1. Electrostatic Discharge (ESD)



---

A sudden discharge of electrostatic electricity can destroy static-sensitive devices or micro-circuitry.

---

Therefore proper packaging and grounding techniques are necessary precautions to prevent damage. Always take the following precautions:

1. Transport boards in ESD-safe containers such as boxes or bags.
2. Keep electrostatic sensitive parts in their containers until they arrive at the ESD-safe workplace.
3. Always be properly grounded when touching a sensitive board, component, or assembly.
4. Store electrostatic-sensitive boards in protective packaging or on antistatic mats.

### 1.1.1. Grounding Methods

By adhering to the guidelines below, electrostatic damage to the device can be avoided:

1. Cover workstations with approved antistatic material. Always wear a wrist strap connected to workplace. Always use properly grounded tools and equipment.
2. Use antistatic mats, heel straps, or air ionizers for more protection.
3. Always handle electrostatically sensitive components by their edge or by their casing.
4. Avoid contact with pins, leads, or circuitry.
5. Turn off power and input signals before inserting and removing connectors or connecting test equipment.
6. Keep work area free of non-conductive materials such as ordinary plastic assembly aids and Styrofoam.
7. Use only field service tools which are conductive, such as cutters, screwdrivers, and vacuum cleaners.
8. Always place drives and boards PCB-assembly-side down on the foam.

## 1.2. Lithium Battery Replacement

If replacing the lithium battery, follow the replacement precautions stated below.

### **⚠ WARNING**

**Do not ingest battery, Chemical Burn Hazard**

This product contains a coin / button cell battery. If the coin / button cell battery is swallowed, it can cause severe internal burns in just 2 hours and can lead to death.

Keep new and used batteries away from children.

If the battery compartment does not close securely, stop using the product and keep it away from children.

If you think batteries might have been swallowed or placed inside any part of the body, seek immediate medical attention.

Replacement of a battery with an incorrect type, that can result in an explosion.

Replace only with the same or equivalent type recommended by the manufacturer. The lithium battery type must be UL recognized.

Disposal of a battery into fire or a hot oven, or mechanically crushing or cutting of a battery, that can result in an explosion.

Leaving a battery in an extremely high temperature surrounding environment that can result in an explosion or the leakage of flammable liquid or gas

---

---

A battery subjected to extremely low air pressure that may result in an explosion or the leakage of flammable liquid or gas

---



---

Do not dispose of lithium batteries in general trash collection. Dispose of the battery according to the local regulations dealing with the disposal of these special materials, (e.g. to the collecting points for dispose of batteries).

---

## 2/ Electromagnetic Compatibility

For detailed information refer to section 10.3 "CE Directives and Standards".

### 2.1. Electromagnetic Compatibility (EU)

This product is intended only for use in industrial areas. The most recent version of the EMC guidelines (EMC Directive 2004/108/EC) apply. If the user modifies and/or adds to the equipment (e.g. installation of add-on cards) the prerequisites for the CE conformity declaration (safety requirements) may no longer apply.

**▲ WARNING**

---

**This is a class A product. In domestic environment this product may cause radio interference in which case the user may be required to take adequate measures.**

---

### 2.2. FCC Statement (USA)

This equipment has been tested and found to comply with the limits for a Class A digital device, pursuant to Part 15 of the FCC Rules. These limits are designed to provide reasonable protection against harmful interference when the equipment is operated in commercial environment. This equipment generates, uses, and can radiate radio frequency energy and, if not installed and used in accordance with the instruction manual, may cause harmful interference to radio communications. Operation of this equipment in residential area is likely to cause harmful interference in which case the user will be required to correct the interference at his own expense.

### 2.3. EMC Compliance (Canada)

The method of compliance is self-declaration to Canadian standard ICES-003:

(English): This Class A digital apparatus complies with the Canadian ICES-003.

(French): Cet appareil numérique de la class A est conforme à la norme NMB-003 du Canada.

## 3/ Shipment and Unpacking

Please check that your package is complete, and contains the items below (according to the ordered unit configuration). If you discover damaged or missing items, please contact your dealer.

### 3.1. Unpacking

Proceed as follows to unpack the unit:

1. Remove packaging.
2. Do not discard the original packaging. Keep it for future relocation.
3. Check the delivery for completeness by comparing it with your order.
4. Please keep the associated paperwork. It contains important information for handling the unit.
5. Check the contents for visible shipping damage.
6. If you notice any shipping damage or inconsistencies between the contents and your order, please contact Kontron for help and information.

### 3.2. Scope of Delivery

#### 3.2.1. Standard

- ▶ 1x KBox F-210 Series (corresponding to the ordered system configuration)
- ▶ 1x Power adapter
- ▶ 1x Power cord (plug type depending on country)
- ▶ 1x Quick installation guide
- ▶ 1x VESA / keyhole mounting kit

#### 3.2.2. Optional Parts

- ▶ Memory module(s) (It may be pre-installed in the system depending on ordered configuration.)
- ▶ Internal 2.5" HDD / SSD (It may be pre-installed in the system depending on ordered configuration.)
- ▶ mSATA SSD(s) (It may be pre-installed in the system depending on ordered configuration.)
- ▶ mPCIe expansion card(s) (It may be pre-installed in the system depending on ordered configuration.)
- ▶ Antenna(s)
- ▶ Stand bracket pair

## 4/ System Overview

The KBox F-210 Series is an embedded system enclosed within a compact chassis, offering excellent processing and graphics performance.

It can be optionally factory-equipped with an mPCIe WLAN card for two antennas and / or an mPCIe WWAN modem card for one antenna. Users may choose the implementation of a 2.5" SATA HDD / SSD and / or of up to two mSATA SSDs (model with Q170 chipset only) as storage media.

The following interfaces are available with the KBox F-210 Series:

### Standard Front Panel:

- ▶ 6x USB 3.0 (model with Q170 chipset)
- ▶ 4x USB 3.0 (model with H110 chipset)
- ▶ 2x USB 2.0 (model with H110 chipset)
- ▶ 1x Line-in
- ▶ 1x Line-out
- ▶ 1x Mic-in
- ▶ 1x S/PDIF
- ▶ 1x Power Button with LED
- ▶ 1x Reset Button
- ▶ 1x Wireless LED
- ▶ 1x Storage LED
- ▶ 1x WWAN Antenna Port

### Standard Rear Panel:

- ▶ 1x DP
- ▶ 2x HDMI 2.0
- ▶ 2x GbE LAN
- ▶ 1x RS232/422/485
- ▶ 1x DC Jack
- ▶ 2x WLAN Antenna Port

### Standard Baseboard and System Expansion Capabilities:

- ▶ 2x DDR4 SO-DIMM memory socket (DIMM1 & DIMM2)
- ▶ 1x 15+7-pin SATA power / data socket (SATA1) for 2.5" SATA HDD / SSD
- ▶ 1x full-sized mSATA / mPCIe socket (MPCIE1, model with Q170 chipset)
- ▶ 1x half-sized mSATA / mPCIe socket (MPCIE2, model with Q170 chipset)
- ▶ 1x full-sized mPCIe socket (MPCIE1, model with H110 chipset)
- ▶ 1x half-sized mPCIe socket (MPCIE2, model with H110 chipset)

### The device is designed to be operated in:

- ▶ Vertical position: mounted on the back of the monitor or inside a control cabinet / custom enclosure / machine (with a VESA / keyhole mounting kit) or
- ▶ Vertical position: mounted on the rack tray shelf inside a control cabinet (with a pair of stand brackets) or
- ▶ Horizontal position: placed as a desktop unit.

### **NOTICE**

When powering on the KBox F-210 Series, make sure that the ventilation slots of the chassis are not obstructed (covered) by any objects.

To provide sufficient heat dissipation by the cooling of the device, do not cover the ventilation slots of the KBox F-210 Series. Do not place any objects on the device. When

---

installing the system, please keep clearance for air circulation.

---

## 4.1. System Expansion Capabilities

### 4.1.1. System Expansion via SATA Interface

The baseboard comes with a 15+7-pin SATA power / data socket. Users can expand the system with a 2.5" SATA HDD / SSD drive.

### 4.1.2. System Expansion via mPCIe / mSATA Card Interface

The baseboard comes with an onboard full-sized mPCIe interface connector and an half-sized mPCIe interface connector for the model with H110 chipset while an onboard full-sized mPCIe / mSATA combo interface connector and an half-sized mPCIe / mSATA combo interface connector are available for the model with Q170 chipset. The switch between mPCIe and mSATA can be taken via the DIP Switch SW2. The default setting is mSATA in case of no specific requirements. The half-sized connector is intended to be used to install an mPCIe WLAN (e.g. Wi-Fi) / Bluetooth / combo card and the full-sized connector for an mPCIe WWAN (e.g. 3G, 4G or 5G) modem card when mPCIe is enabled. Both are used to install mSATA SSDs when mSATA is enabled.

### 4.1.3. System Expansion via Mini SIM Socket

The baseboard comes with an onboard socket for a Mini SIM card.

In order to use the Mini SIM card reader functionality, a corresponding modem card must be installed to the full-sized mPCIe socket of your KBox F-210 Series.

## 4.2. Front I/O Panel

Figure 1: Front I/O Panel (Model with Q170 chipset)

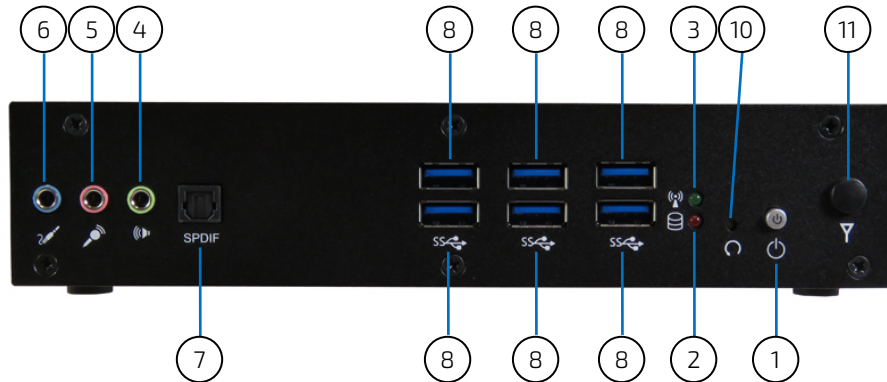
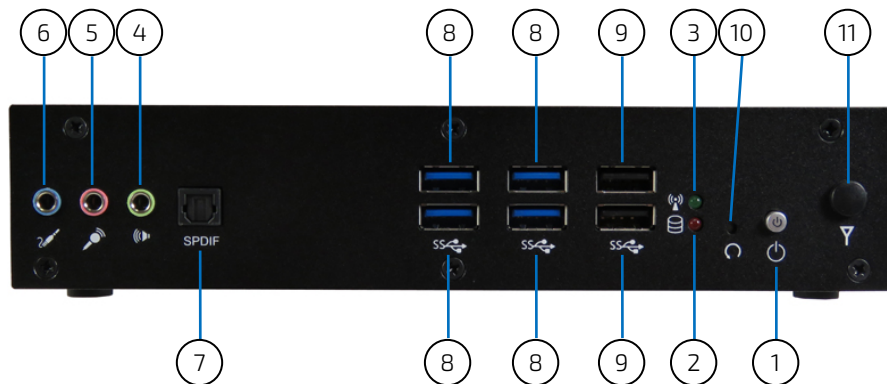

Figure 2: Front I/O Panel (Model with H110 chipset)



- 1 Power Button with LED (See Chapter 4.2.1)
- 2 Storage LED (see Chapter 4.2.2)
- 3 Wireless LED (see Chapter 4.2.3)
- 4 Line-Out (see Chapter 4.2.4)
- 5 Mic-In (see Chapter 4.2.5)
- 6 Line-In (see Chapter 4.2.6)
- 7 S/PDIF (see Chapter 4.2.7)
- 8 USB 3.0 (see Chapter 4.2.8)
- 9 USB 2.0 (see Chapter 4.2.9)
- 10 Reset Button (see Chapter 4.2.10)
- 11 WWAN Antenna Port (see Chapter 4.2.11)

### 4.2.1. Power Button with LED

Press this button to turn the system on or off.

The power LED lights up blue if the system powered on.

**Prerequisite:** The system must be attached by means of the power cord to an appropriate mains (DC).

**⚠WARNING**

Even when the system is turned off via the power button there is still a standby voltage on the baseboard. The unit is only completely disconnected from the DC mains, when the power is removed.

Table 1: Power LED Status

LED Status	Description
Blue LED On	S0 Power Status
Blue LED Blink	S1 Power Status
Red LED Blink	S3 Power Status
Red LED On	S4 / S5 Power Status
LED Off	EUP Power Status

#### 4.2.2. Storage LED

The storage LED blinks red when data is being written into or read from the SATA HDD / SSD and / or mSATA SSD(s).

#### 4.2.3. Wireless LED

The Wireless LED blinks green when the data is transferring over the mPCIe wireless card(s).

#### 4.2.4. Line-Out

The stereo headphone jack is used to connect the system's audio out signal to amplified speakers or headphones.

#### 4.2.5. Mic-In

The microphone jack is designed to connect the microphone used for video conferencing, voice narrations, or simple audio recordings.

#### 4.2.6. Line-In

The Line-in jack is designed to take input from a higher-powered sound source.

#### 4.2.7. S/PDIF

The S/PDIF output connector is designed to carry digital audio signals out to external speakers or deliver compressed AC3 signals to an external Dolby digital decoder.

#### 4.2.8. USB 3.0

The KBox F-210 Series provides six USB 3.0 / 2.0 interfaces for the model with Q170 chipset and four USB 3.0 / USB 2.0 interfaces for the model with H110 chipset. These connectors allow connection of USB 3.0 or USB 2.0 compatible devices to the system.

#### **4.2.9. USB 2.0**

The KBox F-210 Series provides two USB 2.0 / 1.1 interfaces for the model with H110 chipset. These connectors allow connection of USB-compatible devices to the system.

#### **4.2.10. Reset Button**

To clear the CMOS, use the tip of a pen or straightened-out paperclip to press the button briefly (for less than three seconds).

#### **4.2.11. WWAN Antenna Port**

The KBox F-210 Series reserves one covered cutout for the Reverse (RP) SMA connector of the WWAN antenna (mPCIe WWAN modem card with 1 antenna is an option).

## 4.3. Rear I/O Panel

Figure 3: Rear I/O Panel

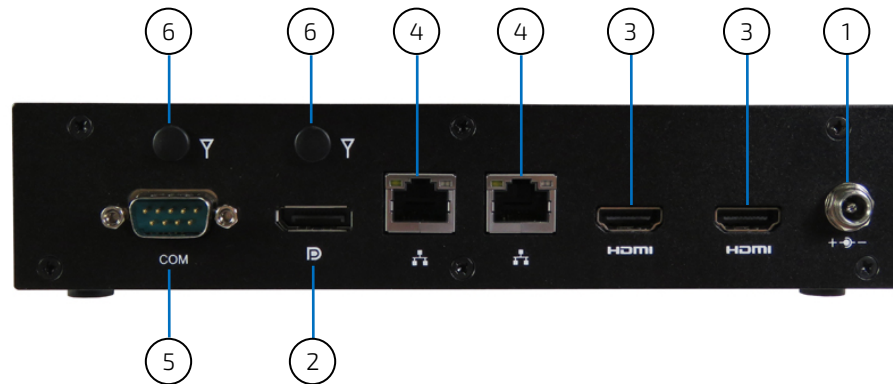

- 1 DC-In (See Chapter 4.3.1)
- 2 DP (see Chapter 4.3.2)
- 3 HDMI 2.0 (see Chapter 4.3.3)
- 4 GbE (see Chapter 4.3.4)
- 5 RS232/422/485 (see Chapter 4.3.5)
- 6 WLAN Antenna Port (see Chapter 4.3.6)

### 4.3.1. DC-In (Lockable DC Jack)

The supplied power adapter converts AC power to DC for use with this jack. Power supplied through this jack supplies power to the PC. To prevent damage to the PC, always use the supplied power adapter.

#### **▲WARNING**

Adapter's power cord shall connected to a socket-outlet with earthing connection

### 4.3.2. DP

An external (digital) display can be connected to this DP connector.

### 4.3.3. HDMI 2.0

An external (digital) display can be connected to this HDMI 2.0 connector.

### 4.3.4. GbE

These connectors are Gigabit Ethernet 10/100/1000 Mbit/s, IEEE 1588 capable interfaces. The connectors are standard 8-pin RJ45 type connectors with status LEDs:

Figure 4: Ethernet LED Status

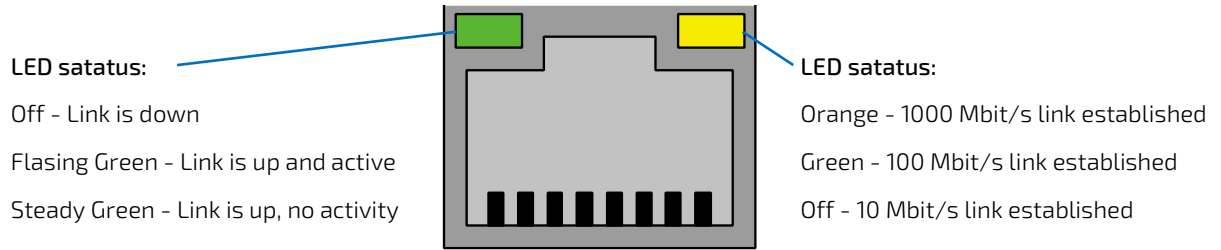

#### 4.3.5. RS232/422/485

COM 1 is provided as a 9-pin D-SUB connector and allows the connection of a serial peripheral. It is designed to support RS232/422/485 serial communication which can be configured via BIOS setup.

#### 4.3.6. WLAN Antenna Port

The KBox F-210 Series reserves two covered cutouts for the Reverse (RP) SMA connectors of the WLAN antennas (mPCIe WLAN card with 2 antennas is an option).

## 4.4. Internal View

Figure 5: Internal view (from bottom side)

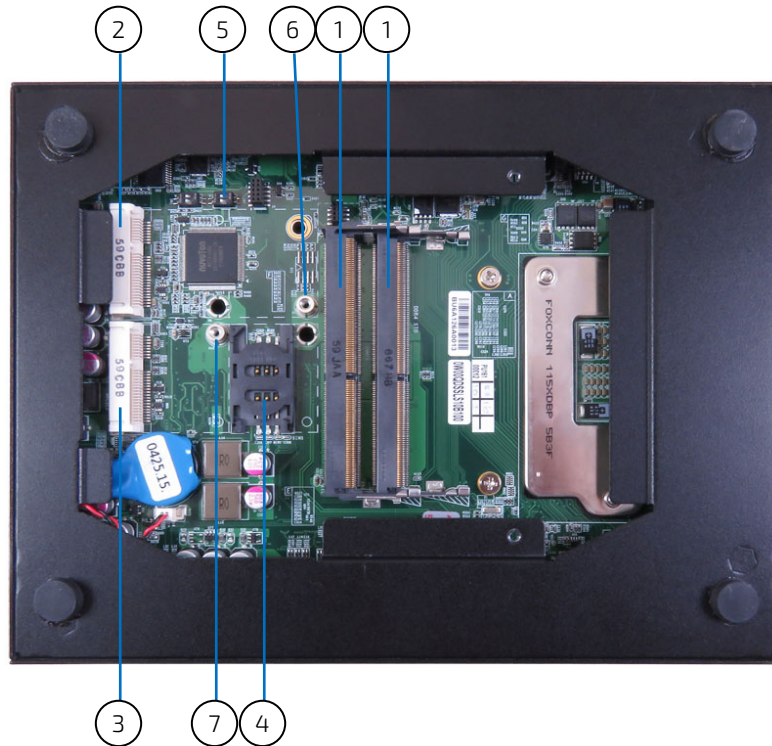

- 1 DDR4 SO-DIMM Memory Socket (DIMM1, see Chapter 4.4.1)
- 2 Full-sized mPCIe (mPCIe / mSATA) Socket (MPCIE1, see Chapter 4.4.3)
- 3 Half-sized mPCIe (mPCIe / mSATA) Socket (MPCIE2, see Chapter 4.4.4)
- 4 Mini SIM Card Socket (SIM1, see Chapter 4.4.5)
- 5 mPCIe / mSATA Selection Switch (SW2, see Chapter 4.4.6)
- 6 Full-sized mPCIe Fixing Bolt
- 7 Half-sized mPCIe Fixing Bolt

Figure 6: Internal view (from top side)

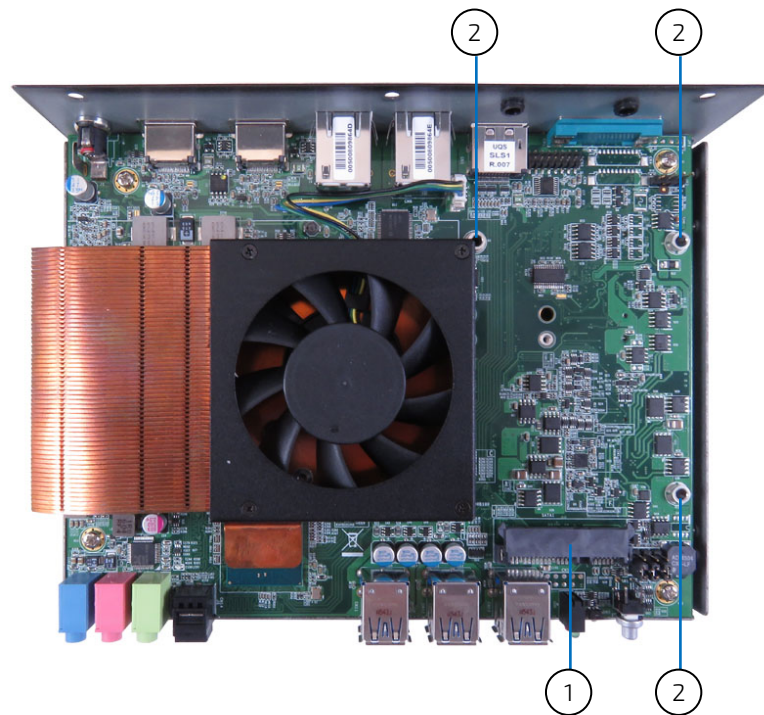

- 1 15+7-pin SATA Power / Data Connector (SATA1, see Chapter 4.4.2)
- 2 2.5" SATA HDD / SSD Fixing Bolt

#### 4.4.1. DDR4 SO-DIMM Memory Socket

The KBox F-210 Series provides two 260-pin DDR4 SO-DIMM socket to install memory RAM.

#### 4.4.2. SATA Power / Data Connector

The KBox F-210 Series provides one 15+7-pin SATA power / data connector to install a 2.5" SATA HDD / SSD.

#### 4.4.3. Full-sized mPCIe (mPCIe / mSATA) Socket

The KBox F-210 Series reserves one mPCIe socket for expansion with a full-sized mPCIe WWAN modem card. The socket is an mPCIe / mSATA combo type for the model with Q170 chipset. The default setting is mSATA for full-sized mSATA SSD installation in case of no specific requirements. To switch between mSATA and mPCIe, see DIP switch setting in Chapter 4.4.6.

#### 4.4.4. Half-sized mPCIe (mPCIe / mSATA) Socket

The KBox F-210 Series reserves another mPCIe socket for expansion with a half-sized mPCIe WLAN, Bluetooth or combo card. The socket is an mPCIe / mSATA combo type for the model with Q170 chipset. The default setting is mSATA for half-sized mSATA SSD installation. To switch between mSATA and mPCIe, see DIP switch setting in Chapter 4.4.6.

#### 4.4.5. Mini SIM Card Socket

The baseboard of the KBox F-210 Series is equipped with an mini SIM card socket. The mini SIM card socket is connected to the full-sized mPCIe socket.



---

**To avoid damage to the SIM card, insert the SIM card before you turn the power on and remove the SIM card after you turn the power off.**

---

#### 4.4.6. mPCIe / mSATA Selection Switch

This DIP Switch is available only for the model with Q170 chipset. It can select which function the mPCIe / mSATA combo socket will be active. The default setting is mSATA in case of no specific requirements.

Figure 7: mPCIe / mSATA Selection Switch (SW2)

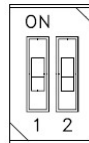

Table 2: Switch Assignment SW2

Switch 1 Status	Description
Off	mSATA enabled for MPCIE1
On	mPCIe enabled for MPCIE1
Switch 2 Status	Switch 1 Status
Off	mSATA enabled for MPCIE2
On	mPCIe enabled for MPCIE2

## 5/ Accessing Internal Components

This section contains important information that you must read before accessing the internal components. You must follow these procedures properly when installing, removing or handling any board.

It is recommended to expand your system with an additional mPCIe and / or mSATA card(s) before it is installed into an equipment, machine or cabinet. Please consider following instruction when you install (or remove) an expansion card.

Before installing/removing an add-on card, please pay attention to the following information:

### **CAUTION**

---

Please observe the "General Safety Instructions for IT-Equipment" provided with the system (refer to the chapter 1/) and the installation instructions in this manual.

Only personnel with appropriate qualifications, trainings and authorization are permitted to install and work with the device.

The installation/removal of HDD / SSD and/or expansion cards may only be performed by a qualified person, according to the description in this manual.

Before removing the cover of the device, make sure that the device is turned off and disconnected from the power supply.

Before you upgrade the device with add-on cards, pay attention to the power specifications in chapter 10/ "Technical Specifications" and make sure that the power consumption of the add-on cards does not exceed 5 W per card.

---



---

Please follow the safety instructions for components that are sensitive to electrostatic discharge (ESD). Failure to observe this warning notice may result in damage to the device or the latter's components.

---



---

Please pay attention to the manufacturer's instructions before installing/removing an add-on card.

---

## 5.1. Opening and Closing the KBox F-210 Series

### **CAUTION**

Before opening the KBox F-210 Series, the system must be switched off and disconnected from the main power supply. Also, disconnect all peripheral devices from the KBox F-210 Series. Before you begin, ensure that you have a clean, flat and ESD-safe surface to work on.

For opening and closing the KBox F-210 Series, please perform the following steps:

1. Close all applications. Shut down the system properly and disconnect the connection to the main power source. Disconnect all peripherals.

#### To access DDR4 SO-DIMM, mPCIe (mPCIe / mSATA) and mini SIM card slots / sockets

2. The KBox F-210 Series should lay on a flat, clean surface with the access cover facing upwards.
3. Loosen and remove the Phillips screws (two located on the bottom side), that secure the access cover to the chassis. Retain the screws for later use.

Figure 8: Descrewing the access cover of the KBox F-210 Series

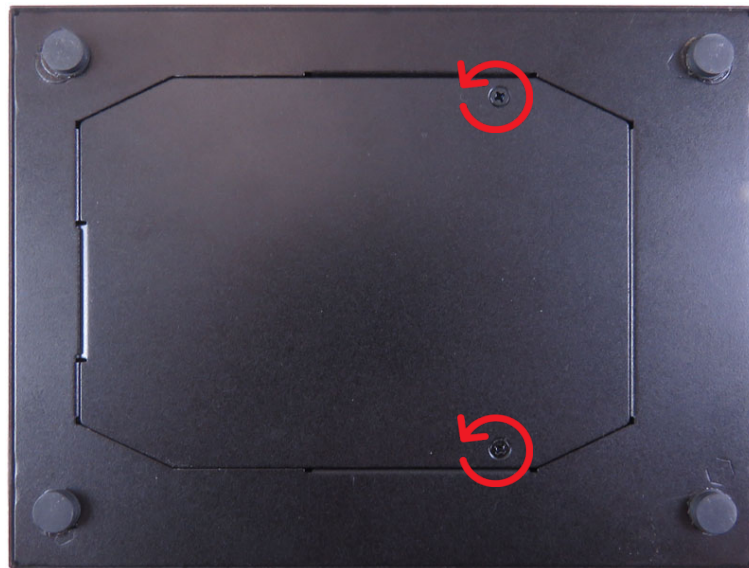

4. Lift the access cover up.
5. Now you have access to the internal DDR4 SO-DIMM, mPCIe (mPCIe / mSATA), mini SIM card slots / sockets respectively in order to remove or install hardware components.
6. For closing replace carefully the access cover to the system and screw it on with the retained screws.
7. Tighten the retained screws when the cover is firmly in place.

#### To access SATA power / data connector

8. The KBox F-210 Series should lay on a flat, clean surface with the top side facing upwards.
9. Loosen and remove the Phillips screws (three located on the front and rear side of the chassis, two on the left and right side respectively), that secure the upper and lower halves of the chassis together. Retain the screws for later use.

Figure 9: Descrewing two chassis halves of the KBox F-210 Series



10. Slide the upper half of the chassis rearward to disengage it from the lower half.

Figure 10: Disengaging the chassis of the KBox F-210 Series



11. Now you access to the SATA power / data connector in order to remove or install 2.5" SATA HDD / SSD.

- Loosen and remove the Phillips screws (four located at the corners of the baseboard), that secure the baseboard to the lower half of the chassis. Retain the screws for later use.

Figure 11: Descrewing the baseboard of the KBox F-210 Series

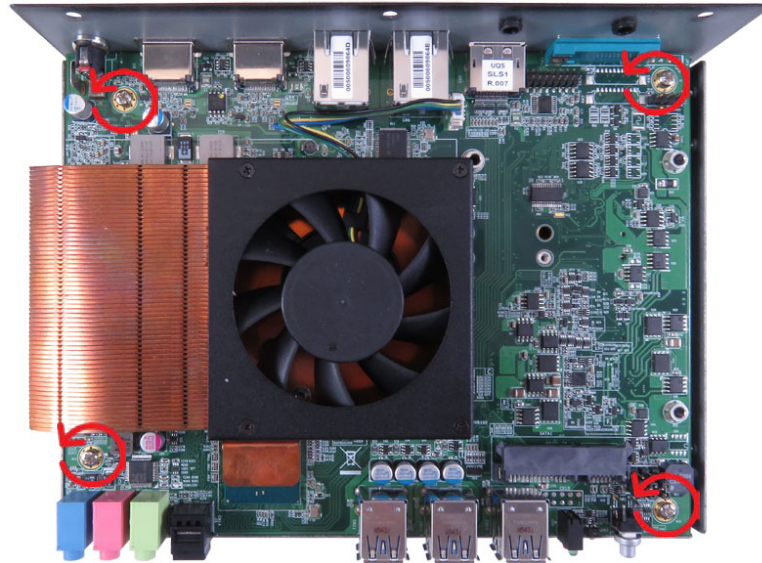

- Lift the baseboard up.
- Now you have access to the 2.5" SATA HDD / SSD fixing holes (Figure 12, pos. 1) on the opposite side of the 2.5" SATA HDD / SSD fixing bolt (Figure 6, pos. 2) in order to screw or descrew the HDD / SSD.

Figure 12: Fixing holes to screw or descrew the HDD / SSD

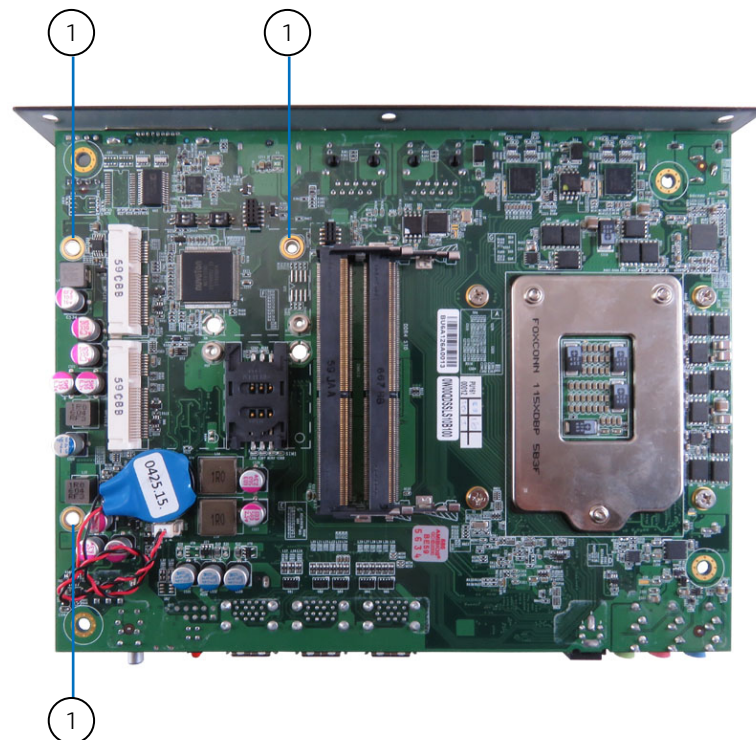

## 1 2.5" SATA HDD / SSD Fixing Hole

15. For re-fixing the baseboard replace it carefully to the lower half of the chassis and screw it on with retained screws.
16. For closing engage carefully two halves of the chassis and screw them together with the retained screws.
17. Tighten the retained screws when the chassis is firmly in place.

### **NOTICE**

When used as intended, the KBox F-210 Series is to operate only in closed condition. Only when the access cover is properly fixed with the screws and the front and / or side(s) with WWAN and / or WLAN antenna(s) are properly installed and secured with the screws, it is ensured that the user does not have access to the internal parts of the KBox F-210 Series.

### 5.1.1. Installing an HDD / SSD

To install a 2.5" HDD / SSD please proceed according to the steps described:

1. Open the device as described in the subsection 5.1 "Opening and Closing the KBox F-210 Series" (step 1 & 8-14).
2. Locate the SATA power / data socket (SATA1) (Figure 6, pos. 1) and the corresponding fixing bolts (Figure 6, pos. 2).
3. Align the notches on the HDD / SSD with the notches in the SATA power / data socket (SATA1, Figure 6, pos. 1). Insert the HDD / SSD into the corresponding socket. Make sure the holes of the fixing bolts (Figure 6, pos. 2) align with the holes of the HDD / SSD.
4. Secure the HDD / SSD with the supplied fastening screws (M3 x 7 mm) from the fixing holes (Figure 12, pos. 1) on the opposite side.
5. In order to close the KBox F-210 Series, proceed step 15 - 17 described in the subsection 5.1 "Opening and Closing the KBox F-210 Series".

### 5.1.2. Installing an mSATA SSD or an mPCIe expansion card

To have access the mPCIe or mSATA / mPCIe combo socket please proceed according to the steps described:

1. Open the device as described in the subsection 5.1 "Opening and Closing the KBox F-210 Series" (step 1-5).
2. Locate the mPCIe or mSATA / mPCIe combo socket (MPCIE1 & MPCIE2) (Figure 5, pos. 2 & 3) and the corresponding fixing bolt (Figure 5, pos. 6 & 7).
3. Align the notches on the mSATA SSD or mPCIe expansion card with the notches in the mPCIe or mSATA / mPCIe combo socket (MPCIE1 & MPCIE2). Insert the mSATA SSD or mPCIe expansion card into the corresponding socket (Figure 5, pos. 2 & 3) and rotate it down with the fixing hole of the card over the fixing bolt.
4. Press the mSATA SSD or mPCIe expansion card down on the side with the fixing hole and secure it with the available fastening screw (Figure 5, pos. 6 & 7).
5. In order to close the KBox F-210 Series, proceed step 6 & 7 described in the subsection 5.1 "Opening and Closing the KBox F-210 Series".

### 5.1.3. Installing the Mini SIM card

To have access the Mini SIM card socket please proceed according to the steps described:

1. Open the device as described in the subsection 5.1 "Opening and Closing the KBox F-210 Series" (step 1-5).
2. Locate the Mini SIM card socket (SIM1) (Figure 5, pos. 4).
3. To unlock the Mini SIM card socket slide the cover of the Mini SIM socket in the direction shown in Figure 13.
4. Lift gently the slot cover and open the slot cover as shown in Figure 13.
5. Slide the Mini SIM card into the left and right card guides of the socket cover and push down the cover in order to close the cover as shown in Figure 13.
6. After closing the cover, lock the cover by sliding the closed cover in the direction shown in Figure 13.

Figure 13: Installing the Mini SIM card

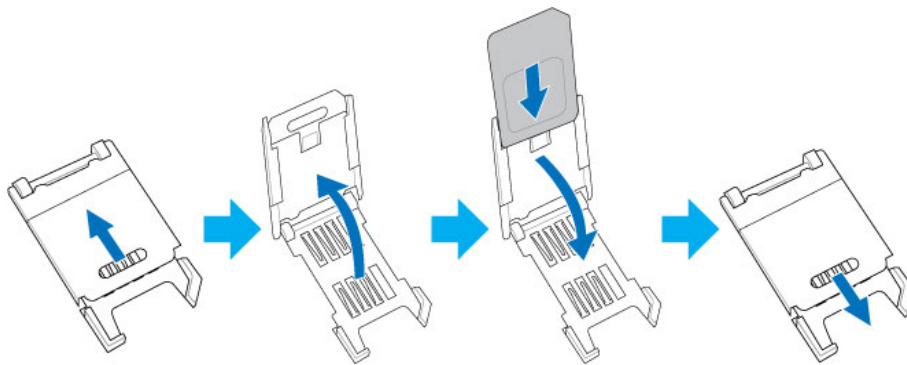

7. In order to close the KBox F-210 Series, proceed step 6 & 7 described in the subsection 5.1 "Opening and Closing the KBox F-210 Series".

## 6/ Thermal Considerations

### 6.1. Available Processors

Please refer to the chapter 10/ "Technical Specifications".



---

The list of processors may be extended over the product lifetime.

---

### 6.2. Convection Cooling

The applied cooling method provides adequate cooling of the device during operation and performs a one-way thermal transfer to the airflow. There are ventilation slots located on the three sides of the KBox F-210 Series. They provide heat dissipation during operation.



---

To provide sufficient heat dissipation for the cooling of the KBox F-210 Series, never cover the ventilation slots of the chassis. Do not place any objects on the device.

---

### 6.3. System Clearance

To provide a maximum of airflow through and around the box, proper distances to surrounding parts must be observed.

### 6.4. Maximum Temperatures



---

The maximum system ambient temperature depends mostly on the power consumption of the processor and the chipset.

---

For the temperature evaluation a specialised tool from Intel® was used to set the processor to a defined workload. Depending on the power consumption one or more cores were set to 75% workload. This includes the graphics core. The tool also handles the usage of the "Turbo Mode" of certain processor types.



---

The processor utilization depends highly on the software used. Software using multicore feature will run on several cores whereas standard software will only utilize one core. In this case the processor will use the "Turbo Mode" to increase the clock for the core with the highest workload, as long as the temperature is within limits.

---

### 6.5. Third Party Components

When the KBox F-210 Series is extended and configured with third party components like mPCIe expansion card and hard drives (HDD or SSD), it has to be taken into account that the air temperature inside the system is higher than the ambient temperature. An approximately internal temperature rise is given for assistance.

## 7/ Installation Instructions

The KBox F-210 Series system is designed for operating:

- ▶ within a control cabinet/ custom enclosure / machine or onto a wall / the back of a monitor by use of a VESA / keyhole mounting kit
- ▶ on a rack tray shelf inside a control cabinet by use of a pair of stand brackets
- ▶ as desktop unit.



---

Expansion card installation should be performed before installing the KBox F-210 Series into control cabinet.

---

### NOTICE

Whenever possible, unpack or pack this product only at EOS/ESD safe work stations. Where a safe work station is not guaranteed, it is important for the user to be electrically discharged before touching the product with his/her hands or tools. This is most easily done by touching a metal part of the system chassis.

Do not handle this product out of its protective enclosure while it is not used for operational purposes unless it is otherwise protected.

Prior any installation work, ensure that there are no live wires on the installation site.

Do not handle the device if there is any damage visible.

Do not operate the KBox F-210 Series with foreign objects inside the chassis.

Further do not insert any retrieval device into the device while it is connected to power.

Kontron rejects all liability for any and all damages resulting from operation of the unit with foreign objects inside the chassis.

The KBox F-210 Series has to be installed and operated only by trained and qualified personnel.

Only personnel with appropriate qualifications, trainings and authorization are permitted to install and work with the Kontron KBox F-210 Series.

This device shall only be installed in or connected to systems that fulfill all necessary technical and specific environmental requirements.

The unit must be placed such that there is sufficient space in front and rear of it for connecting the cables to the I/O interface connectors and for operating the power button.

Leave sufficient free space around the unit to prevent the device from possibly overheating!

Refer also to section 10.1.2 "Mechanical Specifications".

The KBox F-210 Series must be firmly attached to a clean flat and solid mounting surface. Use proper fastening materials suitable for the mounting surface. Ensure that the mounting surface type and the used mounting solution safely support the load of the KBox F-210 Series and the attached components.

Please follow the local / national regulations for grounding.

The voltage feeds must not be overloaded. Adjust the cabling and the overcurrent protection to correspond with the electrical figures indicated on the type label.

The type label is located next to the access cover of the system.

It is recommended that the last cable attached to the system should be the power cable! Refer to the section 7.2 "DC Power Connection" and chapter 8/ "Starting Up".

---

## 7.1. System Mounting

In order to adapt the KBox F-210 Series for mounting Kontron offers different mounting solution such as:

- ▶ KBox F-210 Series configuration with a VESA / keyhole mounting bracket for vertical installation into a control cabinet / custom enclosure / machine or onto a wall / the back of a monitor
- ▶ KBox F-210 Series configuration with a pair of stand brackets for vertical installation on a rack tray shelf inside a control cabinet
- ▶ KBox F-210 Series as desktop unit

### 7.1.1. System Mounting by Use of the VESA / Keyhole Mounting Bracket

Your system is supplied with a VESA / wall mounting bracket (Figure 14).

Figure 14: VESA / keyhole mounting bracket

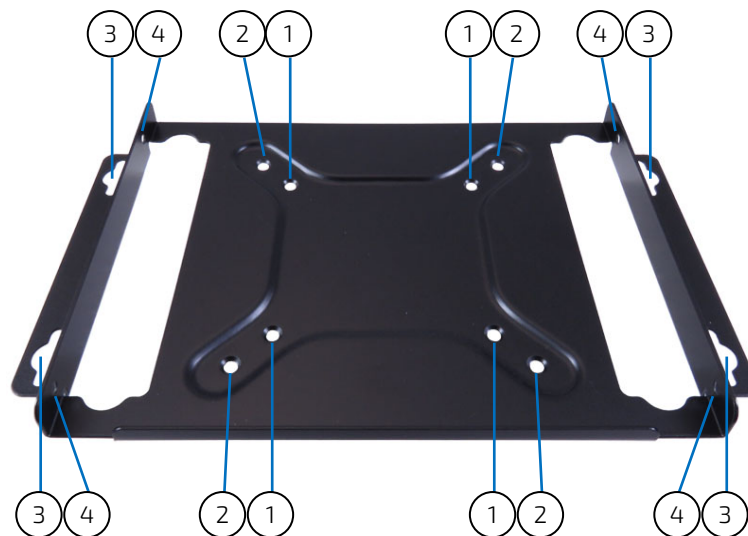

- 1 Mounting Hole for VESA 75 Mount
- 2 Mounting Hole for VESA 100 Mount
- 3 Mounting Hole for Keyhole Mount
- 4 Fixing Hole for Securing KBox F-210 Series

The mounting bracket provides three hole patterns: VESA 75, VESA 100 and another for keyhole mounting. To fasten the bracket, the control cabinet / custom enclosure / machine / monitor / wall must have VESA 75, VESA 100 or corresponding screw pattern for keyhole mounting shown as Figure 15 for mounting.

Figure 15: Hole patterns of VESA / keyhole mounting bracket for KBox F-210 Series

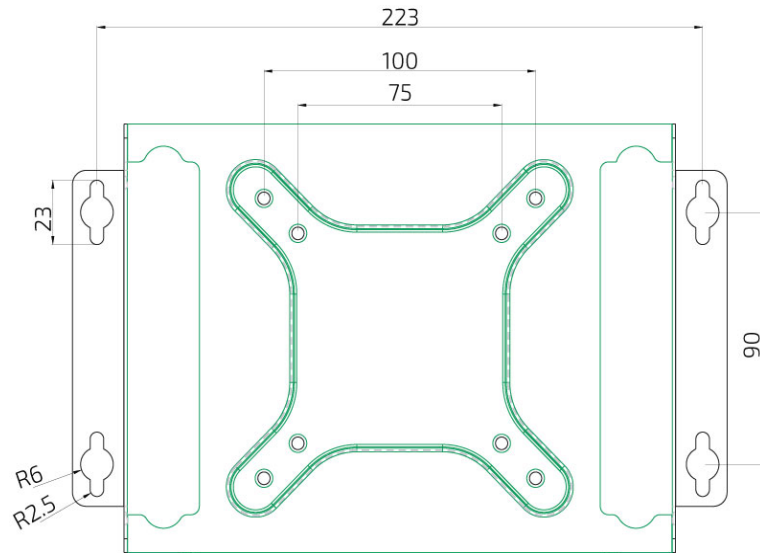

To mount the KBox F-210 Series please proceed according to the steps described:

1. Prepare the mounting surface and the four screw holes for mounting. The mounting bracket is supplied with four M4 x 8 mm screws for VESA mount. For keyhole mount prepare appropriate-sized screws suitable for keyhole slots (see Figure 15.) Screw anchors may be required corresponding to the mounting surface type if no screw holes are available.
2. Secure the mounting bracket to the mounting surface with supplied screws or self-prepared screws depending on mounting type (Figure 16). The following figure takes VESA mounting to a monitor as an example.

Figure 16: Securing the mounting bracket

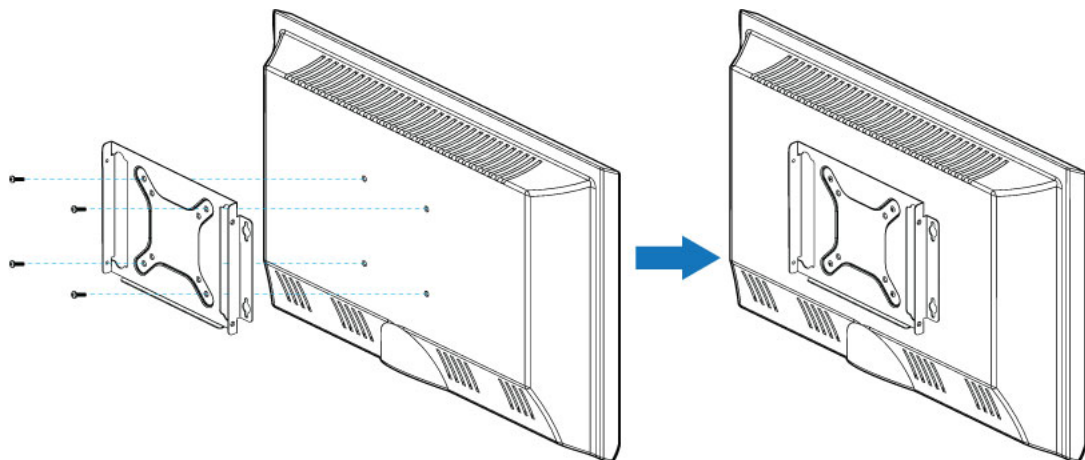

3. Place the KBox F-210 Series onto the VESA / keyhole mounting bracket (Figure 17).

Figure 17: Placing the KBox F-210 Series onto the mounting bracket

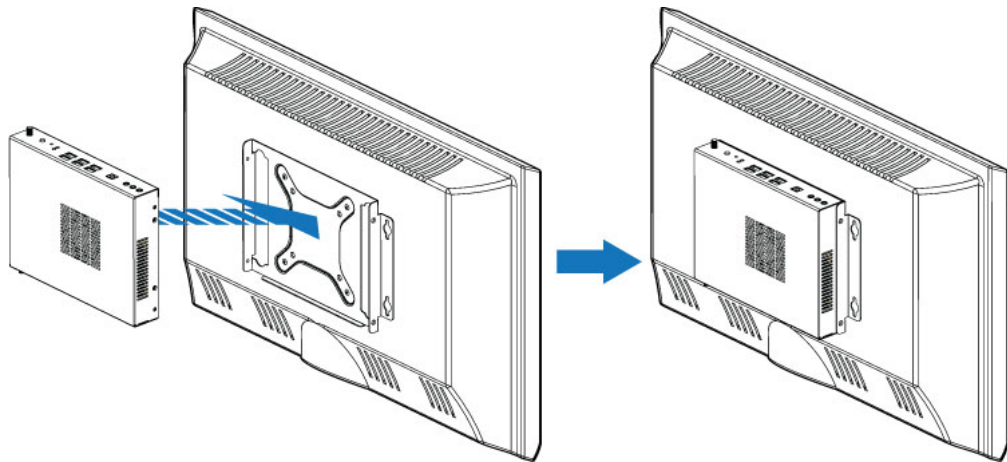

4. Secure the KBox F-210 Series and the mounting bracket together via the fixing holes (Figure 14, pos. 4) with four supplied M3 x 5 mm screws (Figure 18).

Figure 18: Securing the KBox F-210 Series and the mounting bracket together

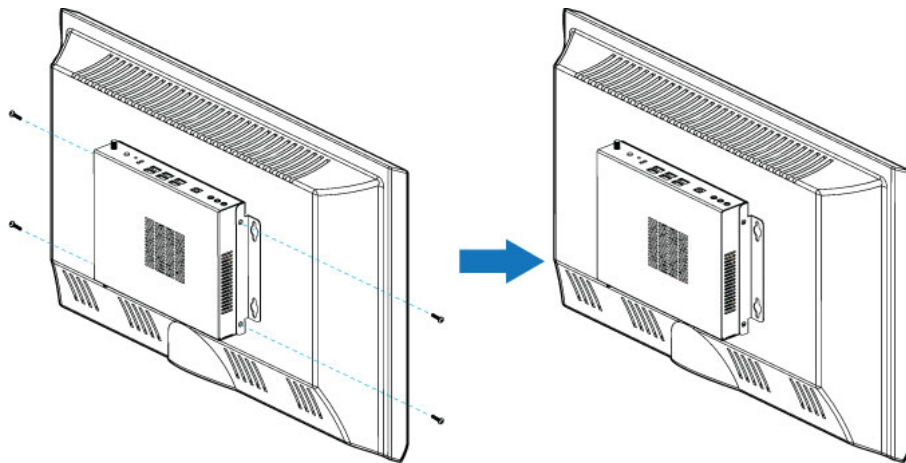

---

For a sufficient air circulation around the device, we recommend keep a proper clearance and not mount / operate any other devices within the clearance around the KBox F-210 Series.

---

## 7.1.2. System Mounting by Use of the Stand Bracket Pair

Depending on the ordered KBox F-210 Series configuration, your system is supplied with a stand bracket pair (Figure 19).

Figure 19: Stand bracket pair

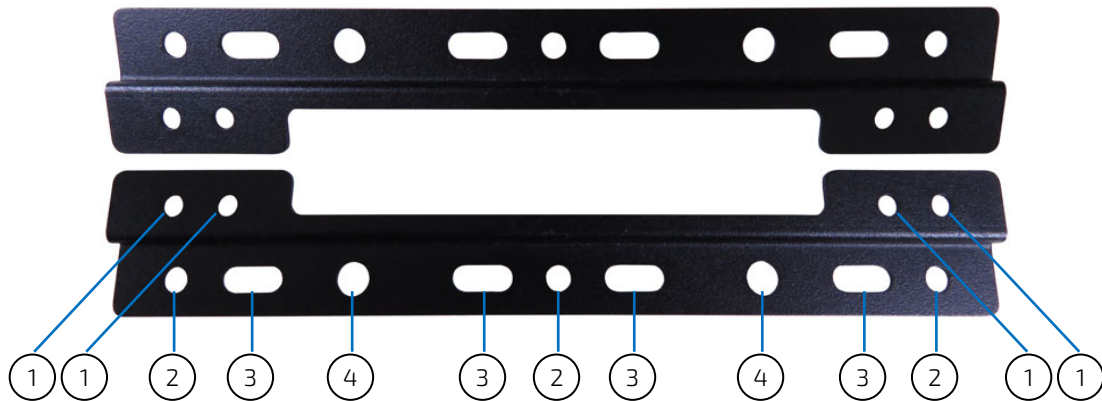

- 1 Fixing Hole for Securing KBox F-210 Series
- 2 4.2 mm Diameter Round Hole for Securing Stand Bracket onto Rack Tray Shelf
- 3 4.2 mm Diameter Slot Hole for Securing Stand Bracket onto Rack Tray Shelf
- 4 5.5 mm Diameter Round Hole for Securing Stand Bracket onto Rack Tray Shelf

To mount the KBox F-210 Series please proceed according to the steps described:

1. Secure the stand bracket pair to the KBox F-210 Series with four M3 x 6 mm screws (Screws are supplied if you order the stand bracket pair from Kontron.) (Figure 20).

Figure 20: Securing the stand bracket pair to the KBox F-210 Series

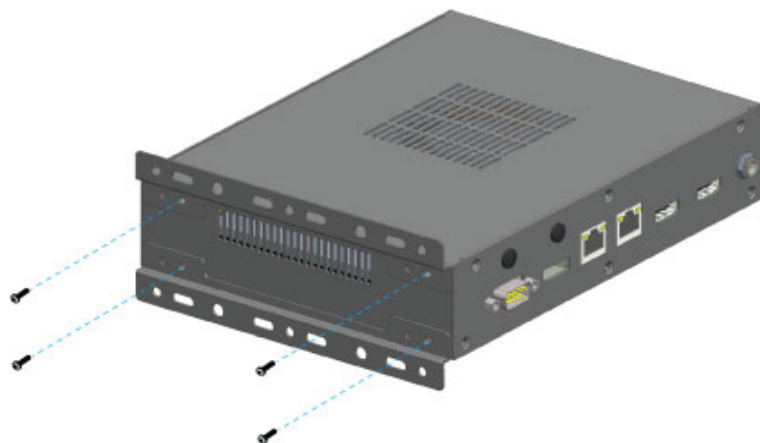

2. Secure the KBox F-210 Series on the rack tray shelf via appropriate holes of the stand bracket pair with appropriate screws (see Figure 19 for hole size) (Figure 21).

Figure 21: Securing the KBox F-210 Series on the rack tray shelf

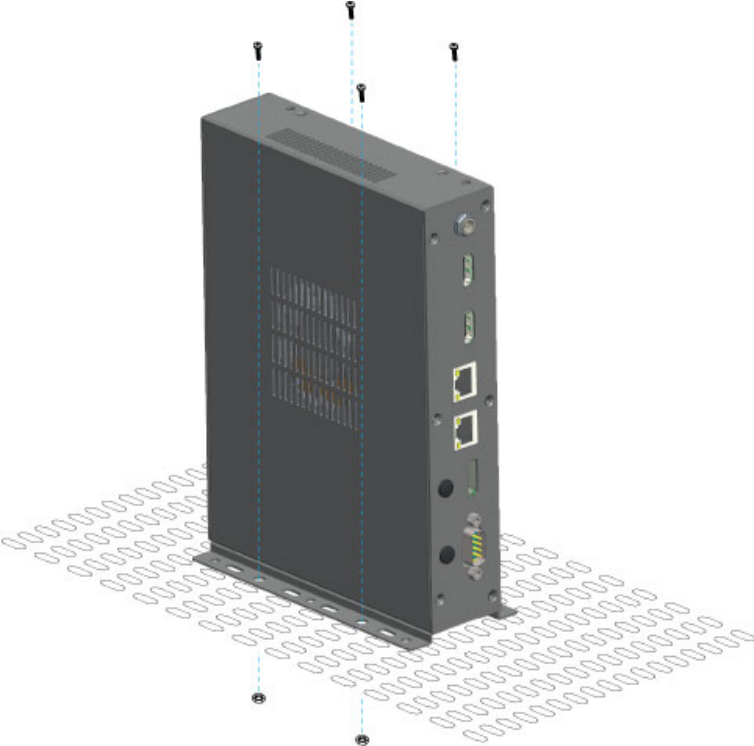

## 7.2. DC Power Connection

The KBox F-210 Series is connected by a DC power input jack (Figure 3, pos. 1) to a DC power source.

The KBox F-210 Series is delivered with a power adapter to convert AC voltage into DC 19V and a power cord to carry AC power to the power adapter.

## 8/ Starting Up



---

The KBox F-210 Series must be only operated with the nominal voltage of 19 V DC of type SELV. For details refer to the chapter 10/ "Technical Specifications".

---

### 8.1. Connecting to DC Power Supply

The DC power input jack (Figure 3, pos. 1) is located on the rear side of the KBox F-210 Series. The KBox F-210 Series will be connected to a AC-to-DC power adapter via the attached male DC power plug and corresponding power cable to couple together the adapter and the AC power outlet.



---

Before using your system, become familiar with the system components and check that everything is connected properly. Following a proper cabling procedure will prevent a false power-on condition, which could result in unit operational failure.

When you install/disconnect the unit, the functional earth connection must always be made first and disconnected last.

Also, it is recommended that the last connections attached to the system should be the power wires!

---

#### **NOTICE**

---

The KBox F-210 Series must be connected DC main power supply complying with the SELV (Safety Extra Low Voltage) requirements of EN 60950-1 standard. It must be observed that wiring and short-circuit/overcurrent protection is performed according to the applicable standards, regulations and respect to the electrical specification of the KBox F-210 Series.

Even when the system is turned off via the power switch (Figure 1, pos. 1 or Figure 2, pos. 1) parts of the system are still energized.

The disconnecting device (fuse/circuit breaker) rating must be in accordance with the wire cross-section and the rated current of the KBox F-210 Series.

---



---

The cables must have some form of support so as to minimize the strain on the unit's connectors.

---

To connect the KBox F-210 Series to a corresponding DC main power supply, please perform the following steps:

1. Connect the power adapter cable to the DC jack (DC IN, Figure 3, pos. 1) of the KBox F-210 Series.
2. Connect the power cable to the power adapter.
3. Connect the power cable to a power outlet.
4. Press the power button (Figure 1, pos. 1 or Figure 2, pos. 1) on the front panel to turn on the system.

## 8.2. Operating System and Hardware Component Drivers

Your system can be supplied optionally with a pre-installed operating system.

If you have ordered your KBox F-210 Series with a pre-installed operating system, all drivers are installed in accordance with the system configuration ordered (optional hardware components). Your system is fully operational when you switch it on for the first time.

If you have ordered the KBox F-210 Series without a pre-installed operating system, you will need to install the operating system and the appropriate drivers for the system configuration you have ordered (optional hardware components) yourself.



---

**You can download the relevant drivers for the installed hardware from our web site at [www.kontron.com](http://www.kontron.com) by selecting the product.**

**Pay attention to the manufacturer specifications of the operating system and the integrated hardware components.**

---

## 9/ Maintenance and Cleaning

Equipment from Kontron requires only minimum servicing and maintenance for proper operation.

- ▶ For light soiling, clean the KBox F-210 Series with a dry cloth. Carefully remove dust from the surface of the chassis using a clean, soft brush.
- ▶ Stubborn dirt should be removed using a mild detergent and a soft cloth.



---

**Do not use steel wool, metallic threads or solvents like abrasives, alcohol, acetone or benzene for cleaning the KBox F-210 Series.**

---

## 10/ Technical Specifications

Table 3: Technical Specifications

System	
Processor	▶ 6th Gen Intel® Core™ / Celeron® S-Series CPU (FCLGA1151 socket, TDP up to 45 W)
Chipset	▶ Intel® H110 / Q170 chipset
Memory	▶ 2x DDR4 SO-DIMM memory socket
Video	
Display Interface	▶ 1x DP (on rear) ▶ 2x HDMI 2.0 (on rear)
Multiple Display	▶ Dual (model with H110 chipset) ▶ Triple (model with Q170 chipset)
Audio	
Audio Codec	▶ Realtek ALC662
Audio Interface	▶ 1x Line-in (on front) ▶ 1x Line-out (on front) ▶ 1x Mic-in (on front) ▶ 1x S/PDIF (on front)
Network Connection	
Ethernet	▶ 2x GbE LAN (RJ45 on rear, Intel® I219-LM, Intel® I210-AT)
Peripheral Connection	
USB	▶ 4x USB 3.0 (Type A on front, model w/ H110 chipset) ▶ 6x USB 3.0 (Type A on front, model w/ Q170 chipset) ▶ 2x USB 2.0 (Type A on front, model w/ H110 chipset)
Serial Port	▶ 1x RS232/422/485 (DB9 on rear)
Storage & Expansion	
Storage & Expansion	▶ 1x 2.5" SATA 3.0 HDD / SSD ▶ 2x mSATA / mPCIe (1x full size, 1x half size, model w/ Q170 chipset) ▶ 2x mPCIe (1x full size, 1x half size, model w/ H110 chipset) ▶ 1x SIM Card Cage (Mini type)
Power	
Input Voltage	▶ DC 19 V
Connector	▶ Lockable DC Jack (on rear)
Firmware	
BIOS	▶ AMI uEFI BIOS w/ 128 Mb SPI Flash
Watchdog	▶ Programmable WDT to generate system reset event
H/W Monitor	▶ Input & Core Voltages, CPU & System Temperatures
Real Time Clock	▶ Chipset integrated RTC
TPM	▶ Supported for model w/ Q170 chipset (Infineon SLB 9660 TPM 1.2)
System Control & Monitoring	

<b>Button, Switch &amp; Indicator</b>	<ul style="list-style-type: none"> <li>▶ 1x Power Button w/ LED (on front)</li> <li>▶ 1x Reset Button (on front)</li> <li>▶ 1x Storage LED (on front)</li> <li>▶ 1x Wireless LED (on front)</li> </ul>
<b>Cooling</b>	
<b>Cooling Method</b>	▶ 1x CPU Smart Fan
<b>Software</b>	
<b>OS Support</b>	<ul style="list-style-type: none"> <li>▶ Windows 7</li> <li>▶ Windows 8</li> <li>▶ Windows 10</li> <li>▶ Linux</li> </ul>

## 10.1. Mechanical Specifications

Table 4: Mechanical Specifications

<b>Construction</b>	Metal Chassis
<b>Dimensions (W x D x H)</b>	200 mm x 152.8 mm x 41.5 mm / 7.87" x 6.02" x 1.63"
<b>Weight</b>	1000 g / 2.20 lb
<b>Mounting</b>	VESA Mount, Keyhole Mount, Stand Mount

### 10.1.1. Mechanical Drawing

Figure 22: Mechanical Drawing

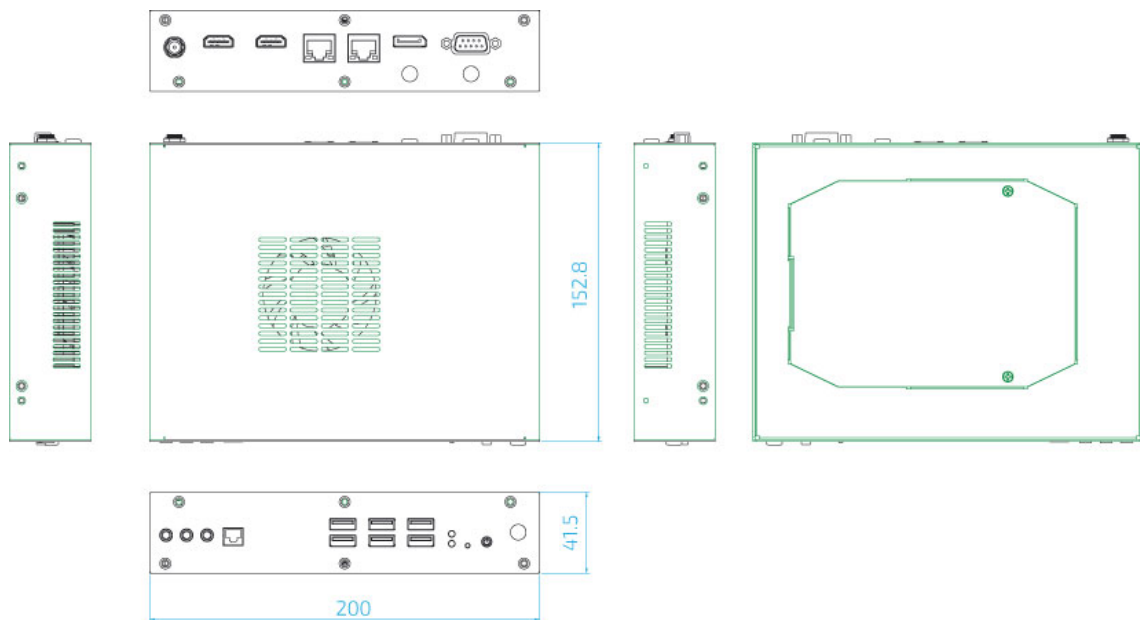

(unit: mm)

## 10.2. Environmental Conditions

Table 5: Environmental Conditions

Operating Temperature	0 °C ~ 50 °C / 32 °F ~ 122 °F
Storage Temperature	-20 °C ~ 80 °C / -4 °F ~ 176 °F
Humidity	0 % ~ 90 %

## 10.3. Standards and Certifications

Table 6: Standards and Certifications

CE Class A	<ul style="list-style-type: none"> <li>▶ EN 55032: 2015 + AC: 2016, CISPR 32: 2015 + COR1: 2016, AS/NZS CISPR 32: 2015</li> <li>▶ EN 61000-3-2: 2014 and IEC 61000-3-2: 2014</li> <li>▶ EN 61000-3-3: 2013 and IEC 61000-3-3: 2013</li> <li>▶ EN 55024: 2010 + A1: 2015 and CISPR 24: 2010 + A1: 2015</li> <li>▶ EN 61000-4-2: 2009 and IEC 61000-4-2: 2008</li> <li>▶ EN 61000-4-3: 2006 + A1: 2008 + A2: 2010 and IEC 61000-4-3: 2006 + A1: 2007 + A2: 2010</li> <li>▶ EN 61000-4-4: 2012 and IEC 61000-4-4: 2012</li> <li>▶ EN 61000-4-5: 2014 and IEC 61000-4-5: 2014</li> <li>▶ EN 61000-4-6: 2014 + AC: 2015 and IEC 61000-4-6: 2013</li> <li>▶ EN 61000-4-8: 2010 and IEC 61000-4-8: 2009</li> <li>▶ EN 61000-4-11: 2004 and IEC 61000-4-11: 2004</li> </ul>
FCC Class A	<ul style="list-style-type: none"> <li>▶ FCC CFR Title 47 Part 15 Subpart B: 2016 - Section 15.107 and 15.109</li> <li>▶ ANSI C63.4-2014</li> <li>▶ ICES-003 Issue 6: 2016</li> </ul>

## 11/Standard Interfaces – Pin Assignments

Low-active signals are indicated by a minus sign.

### 11.1.1. 19 V DC Power Input

Table 7: 19 V DC Power Input (see Figure 3, pos.1)

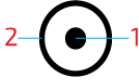
Pin	Signal Name	DC Jack (female)
1	+19V DC	
2	GND	

### 11.1.2. Ethernet Connectors

Table 8: Ethernet Connector (see Figure 3, pos. 4)

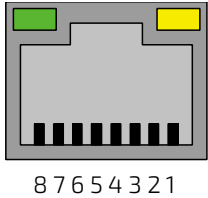
Pin	Signal Name	LAN1, LAN2 (RJ45)
1	TX1+	
2	TX1-	
3	TX2+	
4	TX3+	
5	TX3-	
6	TX2-	
7	TX4+	
8	TX4-	

### 11.1.3. USB 3.0 Port

Table 9: USB 3.0 Port (see Figure 1, pos. 8 & Figure 2, pos. 8)

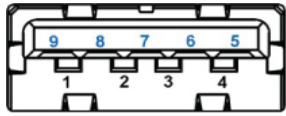
USB 2.0 Contact Pins		USB 3.0 Contact Pins		9-pin USB Connector Type A Version 3.0 / 2.0
Pin	Signal Name	Pin	Signal Name	
1	+USBVCC	5	USB_RX-	
2	USB_D-	6	USB_RX+	
3	USB_D+	7	GND	
4	GND	8	USB_TX-	
		9	USB_TX+	

### 11.1.4. USB 2.0 Port

Table 10: USB 2.0 Port (see Figure 2, pos. 9)

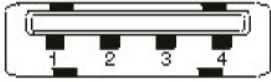
Pin	Signal Name	4-pin USB Connector Type A Version 2.0
1	+USBVCC	
2	USB_D-	
3	USB_D+	
4	GND	

### 11.1.5. DP Connector

Table 11: DP Connector (see Figure 3, pos. 2)

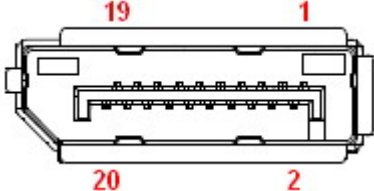
Pin	Signal Name	20-pin DP Connector
1	TX0+	
2	GND	
3	TX0-	
4	TX1+	
5	GND	
6	TX1-	
7	TX2+	
8	GND	
9	TX2-	
10	TX3+	
11	GND	
12	TX3-	
13	GND	
14	GND	
15	AUX+	
16	GND	
17	AUX-	
18	HPD	
19	GND	
20	PWR	

### 11.1.6. HDMI Connector

Table 12: HDMI Connector (see Figure 3, pos. 3)

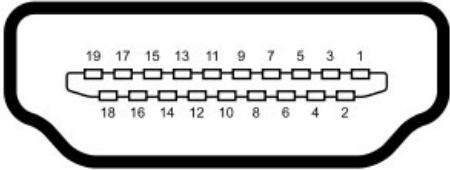
Pin	Signal Name	HDMI Connector Type A Version 2.0
1	TMD Data2+	
2	Ground	
3	TMD Data2-	
4	TMD Data1+	
5	Ground	
6	TMD Data1-	
7	TMD Data0+	
8	Ground	
9	TMD Data0-	
10	TMD Clock+	
11	Ground	
12	TMD Clock-	
13	CEC	
14	Reserved	
15	DDC_CLK	
16	DDC_DATA	
17	Ground	
18	+5 V Power	
19	Hot Plug Detect	

### 11.1.7. RS232/422/485 Serial Port

Table 13: RS232/422/485 Serial Port (see Figure 3, pos. 5)

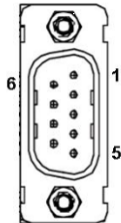
Pin	RS232	RS422	RS485 Half Duplex	RS485 Full Duplex	COM (9-pin D-SUB Male Connector)
1	DCD	TX-	DATA-	TX-	
2	RXD	TX+	DATA+	TX+	
3	TXD	RX+	N/A	RX+	
4	DTR	RX-	N/A	RX-	
5	GND	GND	GND	GND	
6	DSR	N/A	N/A	N/A	
7	RTS	N/A	N/A	N/A	
8	CTS	N/A	N/A	N/A	
9	RI	N/A	N/A	N/A	

### 11.1.8. Line-In Connector

Table 14: Line-In Connector (see Figure 1, pos. 6 & Figure 2, pos. 6)

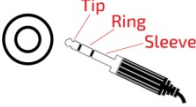
Pin	Signal Name	Line-in Connector & Corresponding Audio Jack Plug
Tip	Line-In_L	
Ring	Line_In_R	
Sleeve	GNG	

### 11.1.9. Line-Out Connector

Table 15: Line-Out Connector (see Figure 1, pos. 4 & Figure 2, pos. 4)

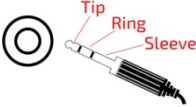
Pin	Signal Name	Line-out Connector & Corresponding Audio Jack Plug
Tip	Line-Out_L	
Ring	Line_Out_R	
Sleeve	GNG	

### 11.1.10. Mic-In Connector

Table 16: Mic-In Connector (see Figure 1, pos. 5 & Figure 2, pos. 5)

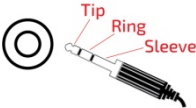
Pin	Signal Name	Mic-in Connector & Corresponding Audio Jack Plug
Tip	Mic-In_L	
Ring	Mic_In_R	
Sleeve	GNG	

## 12/ uEFI BIOS

### 12.1. Starting the uEFI BIOS

The KBox F-210 Series is provided with a Kontron-customized, pre-installed and configured version of AMI Aptio® V uEFI BIOS. AMI BIOS firmware is based on the Unified Extensible Firmware Interface (uEFI) specification and the Intel® Platform Innovation Framework for EFI. This uEFI BIOS provides a variety of new and enhanced functions specifically tailored to the hardware features of the KBox F-210 Series.



---

**The BIOS version covered in this document might not be the latest version. The latest version might have certain differences to the BIOS options and features described in this chapter.**

---

The uEFI BIOS comes with a setup program that provides quick and easy access to the individual function settings for control or modification of the uEFI BIOS configuration. The setup program allows the accessing of various menus that provide functions or access to sub-menus with more specific functions of their own.

To start the uEFI BIOS setup program, follow the steps below:

1. Power on the board.
2. Wait until the first characters appear on the screen (POST messages or splash screen).
3. Press the <DEL> key.
4. If the uEFI BIOS is password-protected, a request for password will appear. Enter either the User Password or the Supervisor Password (see Security menu), press <RETURN>, and proceed with step 5.
5. A setup menu will appear.

The KBox F-210 Series uEFI BIOS setup program uses a hot key-based navigation system. A hot key legend bar is located on the bottom of the setup screens.

The following table provides information concerning the usage of these hot keys.

**Table 17: Navigation Hot Keys Available in the Legend Bar**

Hotkeys	Description
<F1>	The <F1> key invokes the General Help window.
<->	The <Minus> key selects the next lower value within a field.
<+>	The <Plus> key selects the next higher value within a field.
<F2>	The <F2> key loads the previous values.
<F3>	The <F3> key loads the standard default values.
<F4>	The <F4> key saves the current settings and exit the uEFI BIOS setup.
<=> or <=<=>	The <Left/Right> arrows selects major setup menus on the menu bar. For example: Main, Advanced, Security, etc.
<↑> or <↓>	The <Up/Down> arrows selects fields in the current menu. For example: A setup function or a sub-screen.
<ESC>	The <ESC> key exits a major setup menu and enter the Exit setup menu. Pressing the <ESC> key in a sub-menu displays the next higher menu level.
<RERURN>	The <RETURN> key executes a command or select a submenu.

## 12.2. Setup Menus

The Setup utility features shows six menus in the selection bar at the top of the screen:

- ▶ Main
- ▶ Advanced
- ▶ Power
- ▶ Security
- ▶ Boot
- ▶ Save & Exit

The Setup menus are selected via the left and right arrow keys. The currently active menu and the currently active uEFI BIOS Setup item are highlighted in white. Each Setup menu provides two main frames. The left frame displays all available functions. Functions that can be configured are displayed in blue. Functions displayed in gray provide information about the status or the operational configuration. The right frame displays an Item Specific Help window providing an explanation of the respective function.

### 12.2.1. Main Setup Menu

Upon entering the uEFI BIOS Setup program, the Main Setup menu is displayed. This screen lists the Main Setup menu sub-screens and provides basic system information. Additionally functions for setting the system time and date are offered.

**Table 18: Main Setup Menu Sub-Screens and Functions**

Function	Description
BIOS Information	Read only field. Displays information about the system BIOS
Memory Information	Read only field. Displays information about total memory
ME Information	Read only field. Displays information about Intel Management Engine (ME) version
Firmware Information	Code version and firmware information
System Date	Set System Date
System Time	Set System Time

Figure 23: BIOS Main Menu Screen System Data and Time

BIOS SETUP UTILITY					
Main	Advanced	Power	Security	Boot	Save & Exit
Product Information					
Product Name		KBox F-210			
BIOS Version		R0.05 (x64)			
BIOS Build Date		07/11/2016			
ME FW Version		11.0.16.1000			
CPU Information					
Intel® Celeron® CPU G3930TE @ 2.70GHz					
Microcode Revision		39			
Processor Cores		2			
Memory Information					
Total Size		4096 MB			
Frequency		2133 MHz			
System Date		[Tue 07/12/2016]			
System Time		[13:33:28]			
Access Level		Administrator			
				→ ←: Select Screen	
				↑ ↓: Select Item	
				Enter: Select	
				+/-: Change Opt.	
				F1: General Help	
				F2: Previous Values	
				F3: Optimized Defaults	
				F4: Save & Exit	
				ESC: Exit	
Version 2.17.1254. Copyright (C) 2016, American Megatrends, Inc.					

Feature	Option	Description
System Date	[dd/mm/yyyy]	Set the Date. Use Tab to switch between Data elements.
System Time	[hh:mm:ss]	Set the Time. Use Tab to switch between Time elements.

## 12.2.2. Advanced Setup Menu

The Advanced setup menu provides sub-screens and functions for advanced configurations. The following sub-screen functions are included in the menu:

- ▶ LAN & Audio Configuration
- ▶ Display Configuration
- ▶ Super IO Configuration
- ▶ CPU Chipset Configuration
- ▶ SATA Configuration
- ▶ USB Configuration
- ▶ TPM Configuration
- ▶ H/W Monitor

### NOTICE

Setting items on this screen to incorrect values may cause the system to malfunction.

Figure 24: BIOS Advanced Menu

BIOS SETUP UTILITY					
Main	Advanced	Power	Security	Boot	Save & Exit
Onboard LAN1 Controller		[Enabled]			
Onboard LAN1 Boot		[Disabled]			
Onboard LAN2 Controller		[Enabled]			
Onboard LAN2 Boot		[Disabled]			
Audio Controller		[Enabled]			
> Display Configuration					→ ←: Select Screen
> Super IO Configuration					↑ ↓: Select Item
> CPU Chipset Configuration					Enter: Select
> SATA Configuration					+/-: Change Opt.
> USB Configuration					F1: General Help
> TPM Configuration					F2: Previous Values
> H/W Monitor					F3: Optimized Defaults
					F4: Save & Exit
					ESC: Exit
Version 2.17.1254. Copyright (C) 2016, American Megatrends, Inc.					

Feature	Option	Description
Onboard LAN1 Controller	[Disabled], [Enabled]	Select whether to enable or disable Onboard LAN1 Controller.
Onboard LAN1 Boot	[Disabled], [Enabled]	Select whether to enable or disable load onboard PXE (Preboot Execution Environment).
Onboard LAN2 Controller	[Disabled], [Enabled]	Select whether to enable or disable Onboard LAN2 Controller.
Onboard LAN2 Boot	[Disabled], [Enabled]	Select whether to enable or disable load onboard PXE (Preboot Execution Environment).
Audio Controller	[Disabled], [Enabled]	Select whether to enable or disable Audio Controller.

Figure 25: BIOS Advanced Menu - Display Configuration

BIOS SETUP UTILITY					
Main	Advanced	Power	Security	Boot	Save & Exit
Display Information					
Primary Display		[Auto]		→ ←: Select Screen	
UWA Frame Buffer Size		[256MB]		↑ ↓: Select Item	
DVMT Pre-Allocated		[64M]		Enter: Select	
DVMT Total Gfx Mem		[256M]		+/-: Change Opt.	
Primary IGFX Boot Display		[VBIOS Default]		F1: General Help	
				F2: Previous Values	
				F3: Optimized Defaults	
				F4: Save & Exit	
				ESC: Exit	
Version 2.17.1254. Copyright (C) 2016, American Megatrends, Inc.					

Feature	Option	Description
Primary Display	[Auto], [IGFX], [PEG], [PCIE]	Select which graphic controller to be used as the primary display device.
UWA Frame Buffer Size	[128MB], [256MB], [512MB]	Configure the memory size for internal graphic.
DVMT Pre-Allocated	[32M], [64M], [96M], [128M], [160M], [192M], [224M], [256M], [288M], [320M], [352M], [384M], [416M], [448M], [480M], [512M], [1024M]	Select DVMT 5.0 Pre-Allocated (Fixed) Graphics Memory size used by the Internal Graphics Device.
DVMT Total Gfx Mem	[128M], [256M], [MAX]	Select DVMT 5.0 Total Graphic Memory size used by the Internal Graphics Device.
Primary IGFX Boot Display	[VBIOS Default], [CRT], [HDMI], [DP], [HDMI2]	Select the Video Device which will be activated during POST. This has no effect if external graphics present. Secondary boot display selection will appear based on your selection. DOS modes will be supported only on primary display.

Figure 26: BIOS Advanced Menu - Super IO Configuration

BIOS SETUP UTILITY					
Main	Advanced	Power	Security	Boot	Save & Exit
Super IO Chip Parameters.					
> Serial Port 1 Configuration				→ ←: Select Screen ↑ ↓: Select Item Enter: Select +/-: Change Opt. F1: General Help F2: Previous Values F3: Optimized Defaults F4: Save & Exit ESC: Exit	
Version 2.17.1254. Copyright (C) 2016, American Megatrends, Inc.					

Figure 27: BIOS Advanced Menu - Super IO Configuration - Serial Port 1 Configuration

BIOS SETUP UTILITY					
Main	Advanced	Power	Security	Boot	Save & Exit
Serial Port 1 Configuration					
Serial Port		[Enabled]		→ ←: Select Screen ↑ ↓: Select Item Enter: Select +/-: Change Opt. F1: General Help F2: Previous Values F3: Optimized Defaults F4: Save & Exit ESC: Exit	
Device Settings		IO=3F8h; IRQ=4;			
Change Setting		[Auto]			
Serial Port 1 Type		[RS232]			
Version 2.17.1254. Copyright (C) 2016, American Megatrends, Inc.					

Feature	Option	Description
Serial Port	[Disabled], [Enabled]	Select whether to enable or disable Serial Port (COM).
Change Settings	[Auto], [IO=3F8h; IRQ=4;], [IO=3F8h; IRQ=3, 4, 5, 6, 7, 9, 10, 11, 12;], [IO=2F8h; IRQ=3, 4, 5, 6, 7, 9, 10, 11, 12;], [IO=3E8h; IRQ=3, 4, 5, 6, 7, 9, 10, 11, 12;], [IO=2E8h; IRQ=3, 4, 5, 6, 7, 9, 10, 11, 12;]	Select an optional setting for Super IO device.

Feature	Option	Description
Serial Port 1 Type	[RS232], [RS422], [RS485]	Select an appropriate type for Serial Port 1.

Figure 28: BIOS Advanced Menu - CPU Chipset Configuration

BIOS SETUP UTILITY					
Main	Advanced	Power	Security	Boot	Save & Exit
CPU Chipset Configuration					
EIST		[Enabled]		→ ←: Select Screen	
VT-d		[Enabled]		↑ ↓: Select Item	
Active Processor Cores		[All]		Enter: Select	
Limit CPUID Maximum		[Disabled]		+/-: Change Opt.	
Execute Disable Bit		[Enabled]		F1: General Help	
Intel Virtualization Technology		[Disabled]		F2: Previous Values	
				F3: Optimized Defaults	
				F4: Save & Exit	
				ESC: Exit	
Version 2.17.1254. Copyright (C) 2016, American Megatrends, Inc.					

Feature	Option	Description
EIST	[Disabled], [Enabled]	Select whether to enable or disable Enhanced Intel SpeedStep Technology.
VT-d	[Disabled], [Enabled]	Select whether to enable or disable CPU VT-d capability.
Active Processor Cores	[All], [1]	Select the number of cores to enable in each processor package.
Limit CPUID Maximum	[Disabled], [Enabled]	Select whether to limit CPUID maximum value.
Execute Disable Bit	[Disabled], [Enabled]	Select whether to enable or disable Execute Disable Bit functionality, which prevents malicious buffer overflow attacks.
Intel Virtualization Technology	[Disabled], [Enabled]	Select whether to enable or disable Intel Virtualization Technology. A VMM can utilize the additional hardware capabilities provided by Vanderpool Technology when selecting [Enabled].

Figure 29: BIOS Advanced Menu - SATA Configuration

BIOS SETUP UTILITY					
Main	Advanced	Power	Security	Boot	Save & Exit
SATA Configuration					
SATA Controller(s)		[Enabled]		→ ←: Select Screen ↑ ↓: Select Item Enter: Select +/-: Change Opt. F1: General Help F2: Previous Values F3: Optimized Defaults F4: Save & Exit ESC: Exit	
SATA Mode Selection		[AHCI]			
Serial ATA Port 1		Empty			
Port 1		[Enabled]			
mSATA Port 1		Empty			
Port 1		[Enabled]			
mSATA Port 1		Empty			
Port 2		[Enabled]			
Version 2.17.1254. Copyright (C) 2016, American Megatrends, Inc.					

Feature	Option	Description
SATA Controller(s)	[Enabled], [Disabled]	Select whether to enable or disable SATA controller.
SATA Mode Selection	[AHCI]	Determine how SATA controller(s) operate. Note: Device driver support is required for AHCI or RAID. Depending on how the hard disk image was installed, changing this setting may prevent the system from booting.
Port 1, 2	[Disabled], [Enabled]	Select whether to enable or disable SATA Port 1, mSATA Port 1 / 2.

Figure 30: BIOS Advanced Menu - USB Configuration

BIOS SETUP UTILITY					
Main	Advanced	Power	Security	Boot	Save & Exit
USB Configuration					
USB Devices: 1 Keyboard, 1 Mouse				→ ←: Select Screen ↑ ↓: Select Item Enter: Select +/-: Change Opt. F1: General Help F2: Previous Values F3: Optimized Defaults F4: Save & Exit ESC: Exit	
Legacy USB Support		[Enabled]			
XHCI Hand-off		[Disabled]			
USB Mass Storage Driver Support		[Enabled]			
Version 2.17.1254. Copyright (C) 2016, American Megatrends, Inc.					

Feature	Option	Description
Legacy USB Support	[Enabled], [Disabled]	Select whether to enable or disable Legacy USB support. If it is disabled, the USB keyboard and / or USB mouse may be not able to be used without device driver support.
XHCI Hand-off	[Enabled], [Disabled]	Select whether to enable or disable XHCI Hand-off function. This is a workaround for OSeS without XHCI hand-off support. The XHCI ownership change should be claimed by XHCI driver.
USB Mass Storage Driver Support	[Disabled], [Enabled]	Select whether to enable or disable USB Mass Storage Driver Support.

Figure 31: BIOS Advanced Menu - TPM Configuration

BIOS SETUP UTILITY					
Main	Advanced	Power	Security	Boot	Save & Exit
TPM Configuration					
Security Device Support		[Disabled]			
Current Status Information				→ ←: Select Screen ↑ ↓: Select Item Enter: Select +/-: Change Opt. F1: General Help F2: Previous Values F3: Optimized Defaults F4: Save & Exit ESC: Exit	
Version 2.17.1254. Copyright (C) 2016, American Megatrends, Inc.					

Feature	Option	Description
Security Device Support	[Disabled], [Enabled]	Select whether to enable or disable BIOS support for security device.

Figure 32: BIOS Advanced Menu - H/W Monitor

BIOS SETUP UTILITY					
Main	Advanced	Power	Security	Boot	Save & Exit
PC Health Status					
CPU Warning Temperature		[Disabled]			
CPU Temperature		: +36 C			
CPU Fan Speed		: 5075 RPM			
				→ ←: Select Screen	
				↑ ↓: Select Item	
				Enter: Select	
				+/-: Change Opt.	
				F1: General Help	
				F2: Previous Values	
				F3: Optimized Defaults	
				F4: Save & Exit	
				ESC: Exit	
Version 2.17.1254. Copyright (C) 2016, American Megatrends, Inc.					

Feature	Option	Description
CPU Warning Temperature	[Disabled], [80 C], [85 C], [90 C], [95 C]	Determine whether to enable or disable CPU Warning Temperature function and select a temperature that will sound an alarm.

### 12.2.3. Power Setup Menu

The Power setup menu provides functions and a sub-screen for power configurations. The following sub-screen function is included in the menu:

- ▶ WatchDog Timer Configuration

Figure 33: BIOS Power Setup Menu

BIOS SETUP UTILITY					
Main	Advanced	Power	Security	Boot	Save & Exit
Power Configuration					
ACPI Sleep State		[S3 (Suspend to RAM)]			
Restore AC Power Loss		[Power Off]		→ ←: Select Screen	
Power Saving Mode		[Disabled]		↑ ↓: Select Item	
Resume Event Control				Enter: Select	
Resume By LAN Device		[Disabled]		+/-: Change Opt.	
Resume By PCI-E Device		[Disabled]		F1: General Help	
Resume By Ring Device		[Disabled]		F2: Previous Values	
Resume By RTC Alarm		[Disabled]		F3: Optimized Defaults	
> WatchDog Timer Configuration				F4: Save & Exit	
				ESC: Exit	
Version 2.17.1254. Copyright (C) 2016, American Megatrends, Inc.					

Feature	Option	Description
ACPI Sleep State	[Suspend Disabled], [S3 (Suspend to RAM)]	Select whether to enable or disable suspend function and determine an appropriate suspend mode.
Restore AC Power Loss	[Power Off], [Power On], [Last State]	This field controls whether the system will stay on after AC power is removed and then restored. Select [Power Off] if you want the system to remain off after power restored. Select [Power On] if you use a power strip to turn the system on.
Power Saving Mode	[Disabled], [EUP Enabled]	Select whether to enable Power Saving Mode. [EUP Enabled]: The system will enter to EUP Power Saving Mode during power off. [Disabled]: Disables function of all Power Saving Mode.
Resume By LAN Device	[Disabled], [Enabled]	Select whether to enable or disable Wake from LAN Device.
Resume By PCI-E Device	[Disabled], [Enabled]	Select whether to enable or disable Wake from PCIE Device.
Resume By Ring Device	[Disabled], [Enabled]	Select whether to enable or disable Wake from Ring Device.
Resume By RTC Alarm	[Disabled], [Enabled]	Select whether to enable or disable Wake Up on Alarm, to turn on your system on a special day of the month.

Figure 34: BIOS Power Setup Menu - WatchDog Timer Configuration

BIOS SETUP UTILITY					
Main	Advanced	Power	Security	Boot	Save & Exit
WatchDog Timer Configuration					
WDT Function		[Disabled]		→ ←: Select Screen ↑ ↓: Select Item Enter: Select +/-: Change Opt. F1: General Help F2: Previous Values F3: Optimized Defaults F4: Save & Exit ESC: Exit	
Version 2.17.1254. Copyright (C) 2016, American Megatrends, Inc.					

Feature	Option	Description
WDT Function	[Disabled], [Enabled]	Select whether to enable or disable WatchDog Timer function.

### 12.2.4. Security Setup Menu

The Security setup menu provides information about the passwords and functions for specifying the security settings. The passwords are case-sensitive. The KBox F-210 Series provides no factory-set passwords.

**NOTICE**

If there is already a password installed, the system asks for this first. To clear a password, simply enter nothing and acknowledge by pressing <RETURN>. To set a password, enter it twice and acknowledge by pressing <RETURN>.

Figure 35: BIOS Security Setup Menu

BIOS SETUP UTILITY					
Main	Advanced	Power	Security	Boot	Save & Exit
Password Description					
If ONLY the Administrator's password is set, then this only limits access to Setup and is only asked for when entering Setup				→ ←: Select Screen	
If ONLY the User's password is set, then this is a power on password and must be entered to boot or enter Setup. In Setup the User will have Administrator rights					
The password length must be in the following range:					
Minimum Length		3		↑ ↓: Select Item	
Maximum length		20		Enter: Select	
Setup Administrator Password				+/-: Change Opt.	
User Password				F1: General Help	
				F2: Previous Values	
				F3: Optimized Defaults	
				F4: Save & Exit	
				ESC: Exit	
Version 2.17.1254. Copyright (C) 2016, American Megatrends, Inc.					

Feature	Description
Setup Administrator Password	Set administrator password
User Password	Set user password



If only the administrator's password is set, then only access to setup is limited. The password is only entered when entering setup.

If only the user's password is set, then the password is a power on password and must be entered to boot or enter setup. Within the setup menu the user has administrator rights.

Password length requirements are maximum 20 characters and minimum 3 characters.

### 12.2.4.1. Remember the password

It is highly recommended to keep a record of all passwords in a safe place. Forgotten passwords results in being locked out of the system.

If the system cannot be booted because the User Password or the Supervisor Password are not know, contact Kontron Support for further assistance.



---

**HDD security passwords cannot be cleared using the above method.**

---

### 12.2.5. Boot Setup Menu

The boot setup menu lists the for boot device priority order, that is generated dynamically.

Figure 36: BIOS Boot Setup Menu

BIOS SETUP UTILITY					
Main	Advanced	Power	Security	Boot	Save & Exit
Boot Configuration					
Full Screen LOGO Display		[Disabled]			
Setup Prompt Timeout		1		→ ←: Select Screen	
Bootup NumLock State		[On]		↑ ↓ : Select Item	
CSM Support		[Enabled]		Enter: Select	
Boot Option Filter		[Legacy Only]		+/-: Change Opt.	
Boot Option Priorities				F1: General Help	
				F2: Previous Values	
				F3: Optimized Defaults	
				F4: Save & Exit	
				ESC: Exit	
Version 2.17.1254. Copyright (C) 2016, American Megatrends, Inc.					

Feature	Option	Description
Full Screen LOGO Display	[Disabled], [Enabled]	Select whether to enable or disable to display logo screen.
Bootup NumLock State	[On], [Off]	Select the state of the NumLock feature of the keyboard after Startup. [On]: The keys on the keypad will act as numeric keys. [Off]: The keys on the keypad will act as cursor keys.
CSM Support	[Enabled], [Disabled]	Select whether to enable or disable CSM support.
Boot Option Filter	[UEFI and Legacy], [Legacy only], [UEFI only]	Control Legacy / UEFI ROMs priority.

## 12.2.6. Save & Exit Setup Menu

The exit setup menu provides functions for handling changes made to the UEFI BIOS settings and the exiting of the setup program.

Figure 37: BIOS Boot Setup Menu

BIOS SETUP UTILITY					
Main	Advanced	Power	Security	Boot	Save & Exit
Save Changes and Reset					
Discard Changes and Reset					
Save Options				→ ←: Select Screen	
Save Changes				↑ ↓: Select Item	
Discard Changes				Enter: Select	
Restore Defaults				+/-: Change Opt.	
				F1: General Help	
				F2: Previous Values	
				F3: Optimized Defaults	
				F4: Save & Exit	
				ESC: Exit	
Version 2.17.1254. Copyright (C) 2016, American Megatrends, Inc.					

Feature	Description
Save Changes and Exit	Exit system setup after saving the changes. Once you are finished making your selections, choose this option from the Exit menu to ensure the values you selected are saved to the CMOS RAM. The CMOS RAM is sustained by an onboard backup battery and stays on even when the PC is turned off. When you select this option, a confirmation window appears. Select [Yes] to save changes and exit.
Discard Changes and Exit	Exit system setup without saving any changes. Select this option only if you do not want to save the changes that you made to the Setup program. If you made changes to fields other than system date, system time, and password, the BIOS asks for a confirmation before exiting.
Save Changes	Save changes done so far to any of the setup values. This option allows you to save the selections you made. After selecting this option, a confirmation appears. Select [Yes] to save any changes.
Discard Changes	Discards changes done so far to any of the setup values. This option allows you to discard the selections you made and restore the previously saved values. After selecting this option, a confirmation appears. Select [Yes] to discard any changes and load the previously saved values.
Restore Defaults	Restore Default values for all the setup values. This option allows you to load optimal default values for each of the parameters on the Setup menus, which will provide the best performance settings for your system. The F9 key can be used for this operation.

## Appendix A: List of Acronyms



The following table does not contain the complete acronyms used in signal names, signal type definitions or similar. A description of the signals is included in the I/O Connector and Internal connector chapters within this user guide.

Table 19: List of Acronyms

<b>2D</b>	Two-Dimensional
<b>3D</b>	Three-Dimensional
<b>AT</b>	Advanced Technology
<b>ATX</b>	Advanced Technology eXtended
<b>BGA</b>	Ball Grid Array
<b>BIOS</b>	Basic Input / Output System
<b>BSP</b>	Board Support Package
<b>CMOS</b>	Complementary Metal Oxide Semiconductor
<b>CPU</b>	Central Processing Unit
<b>DC</b>	Direct Current
<b>DDC</b>	Display Data Channel
<b>DIO</b>	Digital Input / Output
<b>ECC</b>	Error-Correcting Code
<b>EEE</b>	Electrical and Electronic Equipment
<b>EOS</b>	Electrical OverStress
<b>ESD</b>	ElectroStatic Discharge
<b>GbE</b>	Gigabit Ethernet
<b>HDD</b>	Hard Disk Drive
<b>HDMI</b>	High Definition Multimedia Interface
<b>LAN</b>	Local Area Network
<b>LED</b>	Light Emitting Device
<b>LVDS</b>	Low-Voltage Differential Signaling
<b>ME F/W</b>	Management Engine Firmware
<b>mPCle</b>	mini Peripheral Component Interconnect express
<b>PC-AT</b>	Personal Computer - Advanced Technology
<b>PCB</b>	Printed Circuit Board
<b>PSU</b>	Power Supply Unit
<b>PVC</b>	PolyViny Chloride
<b>PWM</b>	Pulse Width Modulation

<b>RAM</b>	Random Access Memory
<b>ROM</b>	Read-Only Memory
<b>RTC</b>	Real-Time Clock
<b>SATA</b>	Serial Advanced Technology Attachment
<b>SDP</b>	Serial Download Protocol
<b>SELV</b>	Safety Extra-Low Voltage
<b>SIM</b>	Subscriber Identity Module
<b>SMBus</b>	System Management Bus
<b>SoC</b>	System on Chip
<b>SO-DIMM</b>	Small Outline Dual In-line Memory Module
<b>SPD</b>	Serial Presence Detect
<b>SPI</b>	Serial Peripheral Interface
<b>TDP</b>	Thermal Design Power
<b>TPM</b>	Trusted Platform Module
<b>UEFI</b>	Unified Extensible Firmware Interface
<b>USB</b>	Universal Serial Bus
<b>UTP</b>	Update Transfer Protocol
<b>VGA</b>	Video Graphics Array
<b>WDT</b>	WatchDog Timer
<b>WEEE</b>	Waste Electrical and Electronic Equipment



## About Kontron

Kontron is a global leader in Embedded Computing Technology (ECT). As a part of technology group S&T, Kontron offers a combined portfolio of secure hardware, middleware and services for Internet of Things (IoT) and Industry 4.0 applications. With its standard products and tailor-made solutions based on highly reliable state-of-the-art embedded technologies, Kontron provides secure and innovative applications for a variety of industries. As a result, customers benefit from accelerated time-to-market, reduced total cost of ownership, product longevity and the best fully integrated applications overall. For more information, please visit: [www.kontron.com](http://www.kontron.com) / [www.kontron-asia.com](http://www.kontron-asia.com)

---



### PRODUCT CONTACT POINT

#### **KONTRON ASIA INC.**

4F, No. 415, Ti-Ding Blvd.,  
Sec. 2, Neihu District,  
Taipei, Taiwan 11493  
Tel.: + 886 2 2799 2789  
Fax: + 886 2 2799 7399  
[SalesAsia@kontron.com](mailto:SalesAsia@kontron.com)