



# RuggedClient-SKL

Doc. User Guide, Rev. 1.3

Doc. ID: [To be Determined]

This page has been intentionally left blank

 RUGGEDCLIENT-SKL - USER GUIDE

## Disclaimer

Kontron would like to point out that the information contained in this user guide may be subject to alteration, particularly as a result of the constant upgrading of Kontron products. This document does not entail any guarantee on the part of Kontron with respect to technical processes described in the user guide or any product characteristics set out in the user guide. Kontron assumes no responsibility or liability for the use of the described product(s), conveys no license or title under any patent, copyright or mask work rights to these products and makes no representations or warranties that these products are free from patent, copyright or mask work right infringement unless otherwise specified. Applications that are described in this user guide are for illustration purposes only. Kontron makes no representation or warranty that such application will be suitable for the specified use without further testing or modification. Kontron expressly informs the user that this user guide only contains a general description of processes and instructions which may not be applicable in every individual case. In cases of doubt, please contact Kontron.

This user guide is protected by copyright. All rights are reserved by Kontron. No part of this document may be reproduced, transmitted, transcribed, stored in a retrieval system, or translated into any language or computer language, in any form or by any means (electronic, mechanical, photocopying, recording, or otherwise), without the express written permission of Kontron. Kontron points out that the information contained in this user guide is constantly being updated in line with the technical alterations and improvements made by Kontron to the products and thus this user guide only reflects the technical status of the products by Kontron at the time of publishing.

Brand and product names are trademarks or registered trademarks of their respective owners.

©2020 by Kontron AG

Kontron AG

Lise-Meitner-Str. 3-5  
86156 Augsburg  
Germany  
[www.kontron.com](http://www.kontron.com)

## High Risk Applications Hazard Notice

**THIS DEVICE AND ASSOCIATED SOFTWARE ARE NOT DESIGNED, MANUFACTURED OR INTENDED FOR USE OR RESALE FOR THE OPERATION OF NUCLEAR FACILITIES, THE NAVIGATION, CONTROL OR COMMUNICATION SYSTEMS FOR AIRCRAFT OR OTHER TRANSPORTATION, AIR TRAFFIC CONTROL, LIFE SUPPORT OR LIFE SUSTAINING APPLICATIONS, WEAPONS SYSTEMS, OR ANY OTHER APPLICATION IN A HAZARDOUS ENVIRONMENT, OR REQUIRING FAIL-SAFE PERFORMANCE, OR IN WHICH THE FAILURE OF PRODUCTS COULD LEAD DIRECTLY TO DEATH, PERSONAL INJURY, OR SEVERE PHYSICAL OR ENVIRONMENTAL DAMAGE (COLLECTIVELY, "HIGH RISK APPLICATIONS").**

You understand and agree that your use of Kontron devices as a component in High Risk Applications is entirely at your risk. To minimize the risks associated with your products and applications, you should provide adequate design and operating safeguards. You are solely responsible for compliance with all legal, regulatory, safety, and security related requirements concerning your products. You are responsible to ensure that your systems (and any Kontron hardware or software components incorporated in your systems) meet all applicable requirements. Unless otherwise stated in the product documentation, the Kontron device is not provided with error-tolerance capabilities and cannot therefore be deemed as being engineered, manufactured or setup to be compliant for implementation or for resale as device in High Risk Applications. All application and safety related information in this document (including application descriptions, suggested safety measures, suggested Kontron products, and other materials) is provided for reference only.

## Revision History

Revision	Brief Description of Changes	Date of Issue
1.0	Initial Issue	2018-Mar-05
1.1	Update multiple display	2018-Sep-18
1.2	Remove H110 model & update PCIe information	2019-Jul-24
1.3	Update supported type of PCIe card	2020-Jun-08

## Terms and Conditions

Kontron warrants products in accordance with defined regional warranty periods. For more information about warranty compliance and conformity, and the warranty period in your region, visit <http://www.kontron.com/terms-and-conditions>.

Kontron sells products worldwide and declares regional General Terms & Conditions of Sale, and Purchase Order Terms & Conditions. Visit <http://www.kontron.com/terms-and-conditions>.

For contact information, refer to the corporate offices contact information on the last page of this user guide or visit our website [CONTACT US](#).

## Customer Support

Find Kontron contacts by visiting: <http://www.kontron.com/support>.

## Customer Service

As a trusted technology innovator and global solutions provider, Kontron extends its embedded market strengths into a services portfolio allowing companies to break the barriers of traditional product lifecycles. Proven product expertise coupled with collaborative and highly-experienced support enables Kontron to provide exceptional peace of mind to build and maintain successful products.

For more details on Kontron's service offerings such as: enhanced repair services, extended warranty, Kontron training academy, and more visit <http://www.kontron.com/support-and-services/services>.

## Customer Comments

If you have any difficulties using this user guide, discover an error, or just want to provide some feedback, contact [Kontron support](#). Detail any errors you find. We will correct the errors or problems as soon as possible and post the revised user guide on our website.

## Symbols

The following symbols may be used in this user guide

### **⚠ DANGER**

DANGER indicates a hazardous situation which, if not avoided, will result in death or serious injury.

### **⚠ WARNING**

WARNING indicates a hazardous situation which, if not avoided, could result in death or serious injury.

### **NOTICE**

NOTICE indicates a property damage message.

### **⚠ CAUTION**

CAUTION indicates a hazardous situation which, if not avoided, may result in minor or moderate injury.



Electric Shock!

This symbol and title warn of hazards due to electrical shocks (> 60 V) when touching products or parts of products. Failure to observe the precautions indicated and/or prescribed by the law may endanger your life/health and/or result in damage to your material.



ESD Sensitive Device!

This symbol and title inform that the electronic boards and their components are sensitive to static electricity. Care must therefore be taken during all handling operations and inspections of this product in order to ensure product integrity at all times.



HOT Surface!

Do NOT touch! Allow to cool before servicing.



Laser!

This symbol inform of the risk of exposure to laser beam and light emitting devices (LEDs) from an electrical device. Eye protection per manufacturer notice shall review before servicing.



This symbol indicates general information about the product and the user guide.

This symbol also indicates detail information about the specific product configuration.



This symbol precedes helpful hints and tips for daily use.

## For Your Safety

Your new Kontron product was developed and tested carefully to provide all features necessary to ensure its compliance with electrical safety requirements. It was also designed for a long fault-free life. However, the life expectancy of your product can be drastically reduced by improper treatment during unpacking and installation. Therefore, in the interest of your own safety and of the correct operation of your new Kontron product, you are requested to conform with the following guidelines.

### High Voltage Safety Instructions

As a precaution and in case of danger, the power connector must be easily accessible. The power connector is the product's main disconnect device.

#### **CAUTION**

##### Warning

All operations on this product must be carried out by sufficiently skilled personnel only.

#### **CAUTION**



##### Electric Shock!

Before installing a non hot-swappable Kontron product into a system always ensure that your mains power is switched off. This also applies to the installation of piggybacks. Serious electrical shock hazards can exist during all installation, repair, and maintenance operations on this product. Therefore, always unplug the power cable and any other cables which provide external voltages before performing any work on this product.

Earth ground connection to vehicle's chassis or a central grounding point shall remain connected. The earth ground cable shall be the last cable to be disconnected or the first cable to be connected when performing installation or removal procedures on this product.

### Special Handling and Unpacking Instruction

#### **NOTICE**



##### ESD Sensitive Device!

Electronic boards and their components are sensitive to static electricity. Therefore, care must be taken during all handling operations and inspections of this product, in order to ensure product integrity at all times.

Do not handle this product out of its protective enclosure while it is not used for operational purposes unless it is otherwise protected.

Whenever possible, unpack or pack this product only at EOS/ESD safe work stations. Where a safe work station is not guaranteed, it is important for the user to be electrically discharged before touching the product with his/her hands or tools. This is most easily done by touching a metal part of your system housing.

It is particularly important to observe standard anti-static precautions when changing piggybacks, ROM devices, jumper settings etc. If the product contains batteries for RTC or memory backup, ensure that the product is not placed on conductive surfaces, including anti-static plastics or sponges. They can cause short circuits and damage the batteries or conductive circuits on the product.

## Lithium Battery Precautions

If your product is equipped with a lithium battery, take the following precautions when replacing the battery.

### **CAUTION**

**Danger of explosion if the battery is replaced incorrectly.**

- ▶ Replace only with same or equivalent battery type recommended by the manufacturer.
- ▶ Dispose of used batteries according to the manufacturer's instructions.

## General Instructions on Usage

In order to maintain Kontron's product warranty, this product must not be altered or modified in any way. Changes or modifications to the product, that are not explicitly approved by Kontron and described in this user guide or received from Kontron Support as a special handling instruction, will void your warranty.

This product should only be installed in or connected to systems that fulfill all necessary technical and specific environmental requirements. This also applies to the operational temperature range of the specific board version that must not be exceeded. If batteries are present, their temperature restrictions must be taken into account.

In performing all necessary installation and application operations, only follow the instructions supplied by the present user guide.

Keep all the original packaging material for future storage or warranty shipments. If it is necessary to store or ship the product then re-pack it in the same manner as it was delivered.

Special care is necessary when handling or unpacking the product. See Special Handling and Unpacking Instruction.

## Quality and Environmental Management

Kontron aims to deliver reliable high-end products designed and built for quality, and aims to complying with environmental laws, regulations, and other environmentally oriented requirements. For more information regarding Kontron's quality and environmental responsibilities, visit <http://www.kontron.com/about-kontron/corporate-responsibility/quality-management>.

## Disposal and Recycling

Kontron's products are manufactured to satisfy environmental protection requirements where possible. Many of the components used are capable of being recycled. Final disposal of this product after its service life must be accomplished in accordance with applicable country, state, or local laws or regulations.

## WEEE Compliance

The Waste Electrical and Electronic Equipment (WEEE) Directive aims to:

- ▶ Reduce waste arising from electrical and electronic equipment (EEE)
- ▶ Make producers of EEE responsible for the environmental impact of their products, especially when the product become waste
- ▶ Encourage separate collection and subsequent treatment, reuse, recovery, recycling and sound environmental disposal of EEE
- ▶ Improve the environmental performance of all those involved during the lifecycle of EEE



**Environmental protection is a high priority with Kontron.**

**Kontron follows the WEEE directive**

**You are encouraged to return our products for proper disposal.**

# Table of Contents

Symbols.....	6
<b>For Your Safety</b> .....	<b>7</b>
High Voltage Safety Instructions .....	7
Special Handling and Unpacking Instruction .....	7
Lithium Battery Precautions.....	8
<b>General Instructions on Usage</b> .....	<b>8</b>
<b>Quality and Environmental Management</b> .....	<b>8</b>
Disposal and Recycling.....	8
WEEE Compliance.....	8
<b>Table of Contents</b> .....	<b>9</b>
<b>List of Tables</b> .....	<b>11</b>
<b>List of Figures</b> .....	<b>11</b>
<b>1/ General Safety Instructions for IT Equipment</b> .....	<b>13</b>
1.1. Electrostatic Discharge (ESD).....	15
1.1.1. Grounding Methods .....	15
1.2. Lithium Battery Replacement .....	15
<b>2/ Electromagnetic Compatibility</b> .....	<b>16</b>
2.1. Electromagnetic Compatibility (EU).....	16
2.2. FCC Statement (USA).....	16
2.3. EMC Compliance (Canada) .....	16
<b>3/ Shipment and Unpacking</b> .....	<b>17</b>
3.1. Unpacking .....	17
3.2. Scope of Delivery .....	17
3.2.1. Standard .....	17
3.2.2. Optional Parts .....	17
<b>4/ System Overview</b> .....	<b>18</b>
4.1. System Expansion Capabilities .....	18
4.1.1. System Expansion via SATA Interface.....	18
4.1.2. System Expansion via mSATA / mPCIe Card Interface .....	19
4.1.3. System Expansion via PCIe x16 Slot .....	19
4.2. Rear I/O Panel .....	20
4.2.1. 2-pin Phoenix DC-In Power Connector.....	21
4.2.2. 2.5 mm Jack DC-In Power Connector.....	21
4.2.3. Power Switch .....	21
4.2.4. DP.....	21
4.2.5. DVI-D .....	21
4.2.6. Line-In.....	21
4.2.7. Line-Out.....	21
4.2.8. Mic-In.....	21
4.2.9. GbE.....	22
4.2.10. USB 3.0.....	22
4.2.11. USB 2.0 .....	22
4.2.12. RS232/422/485.....	22
4.2.13. RS232 .....	22
4.2.14. PCIe x16 Add-on Card Slot (Optionally) .....	22
4.3. Top I/O Panel.....	24

4.3.1. Antenna.....	24
<b>5/ Thermal Considerations .....</b>	<b>25</b>
5.1. Available Processors.....	25
5.2. Convection Cooling.....	25
5.3. System Clearance.....	25
5.4. Maximum Temperatures.....	25
5.5. Third Party Components .....	25
<b>6/ Installation Instructions.....</b>	<b>26</b>
6.1. System Mounting.....	27
6.1.1. System Mounting by Use of the Mounting Clamps.....	27
6.1.2. System Mounting by Use of a VESA Mounting Kit.....	29
6.2. DC Power Connection.....	32
6.2.1. Cabling.....	32
<b>7/ Starting Up.....</b>	<b>33</b>
7.1. Connecting to DC Power Supply.....	33
7.2. Operating System and Hardware Component Drivers.....	34
<b>8/ Maintenance and Cleaning .....</b>	<b>35</b>
8.1. Touch Screen Care and Cleaning .....	35
8.2. Replacing the Lithium Battery .....	35
<b>9/ Technical Specifications.....</b>	<b>36</b>
9.1. Mechanical Specifications.....	37
9.1.1. Mechanical Drawing.....	38
9.2. Environmental Conditions .....	38
9.3. Standards and Certifications.....	39
<b>10/ Standard Interfaces – Pin Assignments .....</b>	<b>40</b>
10.1.1. Phoenix Connector .....	40
10.1.2. DC Jack.....	40
10.1.3. Ethernet Connectors.....	40
10.1.4. USB 3.0 Port.....	40
10.1.5. USB 2.0 Port .....	41
10.1.6. DP Connector.....	41
10.1.7. DVI-D Connector.....	42
10.1.8. RS232/422/485 Serial Port .....	43
10.1.9. RS232 Serial Port .....	43
10.1.10. Line-In Connector .....	43
10.1.11. Line-Out Connector .....	44
10.1.12. Mic-In Connector.....	44
<b>11/ uEFI BIOS .....</b>	<b>45</b>
11.1. Starting the uEFI BIOS.....	45
11.2. Setup Menus .....	46
11.2.1. Main Setup Menu .....	46
11.2.2. Advanced Setup Menu.....	48
11.2.3. Power Setup Menu .....	64
11.2.4. Security Setup Menu.....	66
11.2.4.1. Remember the password.....	67
11.2.5. Boot Setup Menu .....	68
11.2.6. Save & Exit Setup Menu.....	69
<b>Appendix A: List of Acronyms.....</b>	<b>70</b>
About Kontron .....	71

## List of Tables

Table 1: Specification for mounting by use of the mounting clamps .....	27
Table 2: Technical Specifications .....	36
Table 3: Mechanical Specifications .....	37
Table 4: Environmental Conditions .....	38
Table 5: Standards and Certifications .....	39
Table 6: Phoenix Connector (see Figure 1, pos.1) .....	40
Table 7: DC Jack (see Figure 1, pos.2) .....	40
Table 8: Ethernet Connector (see Figure 1, pos. 9).....	40
Table 9: USB 3.0 Port (see Figure 1, pos. 10).....	40
Table 10: USB 2.0 Port (see Figure 1, pos. 11).....	41
Table 11: DP Connector (see Figure 1, pos. 4).....	41
Table 12: DVI-D Connector (see Figure 1, pos. 5).....	42
Table 13: RS232/422/485 Serial Port (see Figure 1, pos. 12).....	43
Table 14: RS232 Serial Port (see Figure 1, pos. 13).....	43
Table 15: Line-In Connector (see Figure 1, pos. 6).....	43
Table 16: Line-Out Connector (see Figure 1, pos. 7) .....	44
Table 17: Mic-In Connector (see Figure 1, pos. 8).....	44
Table 18: Navigation Hot Keys Available in the Legend Bar .....	45
Table 19: Main Setup Menu Sub-Screens and Functions .....	46
Table 20: List of Acronyms.....	70

## List of Figures

Figure 1: Rear I/O Panel .....	20
Figure 2: Ethernet LED Status.....	22
Figure 3: Maximum Length for PCIe Add-on Card .....	22
Figure 4: Top I/O Panel .....	24
Figure 5: Mounting clamp .....	27
Figure 6: Insert the system into the cutout .....	28
Figure 7: Hook mounting clamps into mounting openings .....	28
Figure 8: VESA mounting hole locations .....	29
Figure 9: Optional VESA mounting kit .....	30
Figure 10: Secure the base mounting bracket .....	30
Figure 11: Secure the hooked mounting bracket onto the RuggedClient-SKL .....	30
Figure 12: Secure the RuggedClient-SKL onto the mounting surface .....	31
Figure 13: Phoenix power plug terminal .....	32
Figure 14: Mechanical Drawing .....	38
Figure 15: BIOS Main Menu Screen System Data and Time .....	47
Figure 16: BIOS Advanced Menu.....	49
Figure 17: BIOS Advanced Menu - Display Configuration .....	50
Figure 18: BIOS Advanced Menu - Super IO Configuration.....	52
Figure 19: BIOS Advanced Menu - Super IO Configuration - Serial Port 1 Configuration .....	52
Figure 20: BIOS Advanced Menu - Super IO Configuration - Serial Port 2 Configuration.....	53
Figure 21: BIOS Advanced Menu - Super IO Configuration - Serial Port 3 Configuration* .....	54
Figure 22: BIOS Advanced Menu - Super IO Configuration - Serial Port 4 Configuration* .....	55
Figure 23: BIOS Advanced Menu - Super IO Configuration - Serial Port 5 Configuration* .....	56
Figure 24: BIOS Advanced Menu - Super IO Configuration - Serial Port 6 Configuration* .....	57
Figure 25: BIOS Advanced Menu - CPU Chipset Configuration .....	58
Figure 26: BIOS Advanced Menu - SATA Configuration .....	59
Figure 27: BIOS Advanced Menu - USB Configuration.....	60
Figure 28: BIOS Advanced Menu - AMT Configuration .....	61
Figure 29: BIOS Advanced Menu - Network Stack.....	62

Figure 30: BIOS Advanced Menu - H/W Monitor..... 63  
Figure 31: BIOS Power Setup Menu..... 64  
Figure 32: BIOS Power Setup Menu - WatchDog Timer Configuration..... 65  
Figure 33: BIOS Security Setup Menu..... 66  
Figure 34: BIOS Boot Setup Menu ..... 68  
Figure 35: BIOS Save & Exit Setup Menu..... 69

# 1/ General Safety Instructions for IT Equipment

## **⚠ WARNING**

Please read this chapter carefully and take careful note of the instructions, which have been compiled for your safety and to ensure to apply in accordance with intended regulations. If the following general safety instructions are not observed, it could lead to injuries to the operator and/or damage of the product; in cases of nonobservance of the instructions Kontron is exempt from accident liability, this also applies during the warranty period.

The product has been built and tested according to the basic safety requirements for low voltage (LVD) applications and has left the manufacturer in safety-related, flawless condition. To maintain this condition and also to ensure safe operation, the operator must not only observe the correct operating conditions for the product but also the following general safety instructions:

- ▶ The product must be used as specified in the product documentation, in which the instructions for safety for the product and for the operator are described. These contain guidelines for setting up, installation and assembly, maintenance, transport or storage.
- ▶ The on-site electrical installation must meet the requirements of the country's specific local regulations.
- ▶ If a power cable comes with the product, only this cable should be used. Do not use an extension cable to connect the product.
- ▶ To guarantee that sufficient air circulation is available to cool the product, please ensure that the ventilation openings are not covered or blocked. If an air filter is provided, this should be cleaned regularly. Do not place the system close to heat sources or damp places. Make sure the system is well ventilated.
- ▶ Only devices or parts which fulfill the requirements of SELV circuits (Safety Extra Low Voltage) as stipulated by IEC 60950-1 may be connected to the available interfaces.
- ▶ Before opening the device, make sure that the device is disconnected from the mains.
- ▶ Switching off the device by its power button does not disconnect it from the mains. Complete disconnection is only possible if the power cable is removed from the wall plug or from the device. Ensure that there is free and easy access to enable disconnection.
- ▶ The device may only be opened for the insertion or removal of add-on cards (depending on the configuration of the system). This may only be carried out by qualified operators.
- ▶ If extensions are being carried out, the following must be observed:
  - ▶ All effective legal regulations and all technical data are adhered to.
  - ▶ The power consumption of any add-on card does not exceed the specified limitations.
  - ▶ The current consumption of the system does not exceed the value stated on the product label.
- ▶ Only original accessories that have been approved by Kontron can be used.
- ▶ Please note: safe operation is no longer possible when any of the following applies:
  - ▶ The device has visible damages.
  - ▶ The device is no longer functioning.

In this case the device must be switched off and it must be ensured that the device can no longer be operated.

**Additional safety instructions for DC power supply circuits**

- ▶ To guarantee safe operation of devices with DC power supply voltages larger than 60 volts DC or a power consumption larger than 240 VA, please observe that:
  - ▶ the device is set up, installed and operated in a room or enclosure marked with "RESTRICTED ACCESS", if there are no safety messages on product as safety signs and labels on the device itself.
  - ▶ no cables or parts without insulation in electrical circuits with dangerous voltage or power should be touched directly or indirectly
  - ▶ a reliable protective earthing connection is provided
  - ▶ a suitable, easily accessible disconnecting device is used in the application (e.g. overcurrent protective device), if the device itself is not disconnectable
  - ▶ a disconnect device, if provided in or as part of the equipment, shall disconnect both poles simultaneously
  - ▶ interconnecting power circuits of different devices cause no electrical hazards
- ▶ A sufficient dimensioning of the power cable wires must be selected – according to the maximum electrical specifications on the product label – as stipulated by EN60950-1 or VDE0100 or EN60204 or UL508 regulations.
- ▶ The devices do not generally fulfill the requirements for "centralized DC power systems" (UL 60950-1, Annex NAB; D2) and therefore may not be connected to such devices!

## 1.1. Electrostatic Discharge (ESD)



---

A sudden discharge of electrostatic electricity can destroy static-sensitive devices or micro-circuitry.

---

Therefore proper packaging and grounding techniques are necessary precautions to prevent damage. Always take the following precautions:

1. Transport boards in ESD-safe containers such as boxes or bags.
2. Keep electrostatic sensitive parts in their containers until they arrive at the ESD-safe workplace.
3. Always be properly grounded when touching a sensitive board, component, or assembly.
4. Store electrostatic-sensitive boards in protective packaging or on antistatic mats.

### 1.1.1. Grounding Methods

By adhering to the guidelines below, electrostatic damage to the device can be avoided:

1. Cover workstations with approved antistatic material. Always wear a wrist strap connected to workplace. Always use properly grounded tools and equipment.
2. Use antistatic mats, heel straps, or air ionizers for more protection.
3. Always handle electrostatically sensitive components by their edge or by their casing.
4. Avoid contact with pins, leads, or circuitry.
5. Turn off power and input signals before inserting and removing connectors or connecting test equipment.
6. Keep work area free of non-conductive materials such as ordinary plastic assembly aids and Styrofoam.
7. Use only field service tools which are conductive, such as cutters, screwdrivers, and vacuum cleaners.
8. Always place drives and boards PCB-assembly-side down on the foam.

## 1.2. Lithium Battery Replacement

If replacing the lithium battery, follow the replacement precautions stated below.

### **▲WARNING**

---

Danger of explosion when replacing with wrong type of battery. Replace only with the same or equivalent type recommended by the manufacturer. The lithium battery type must be UL recognized.

---



---

Do not dispose of lithium batteries in general trash collection. Dispose of the battery according to the local regulations dealing with the disposal of these special materials, (e.g. to the collecting points for dispose of batteries).

---

## 2/ Electromagnetic Compatibility

For detailed information refer to section 9.3 "Standards and Certifications".

### 2.1. Electromagnetic Compatibility (EU)

This product is intended only for use in industrial areas. The most recent version of the EMC guidelines (EMC Directive 2004/108/EC) apply. If the user modifies and/or adds to the equipment (e.g. installation of add-on cards) the prerequisites for the CE conformity declaration (safety requirements) may no longer apply.

#### **▲ WARNING**

---

**This is a class A product. In domestic environment this product may cause radio interference in which case the user may be required to take adequate measures.**

---

### 2.2. FCC Statement (USA)

This equipment has been tested and found to comply with the limits for a Class A digital device, pursuant to Part 15 of the FCC Rules. These limits are designed to provide reasonable protection against harmful interference when the equipment is operated in commercial environment. This equipment generates, uses, and can radiate radio frequency energy and, if not installed and used in accordance with the instruction manual, may cause harmful interference to radio communications. Operation of this equipment in residential area is likely to cause harmful interference in which case the user will be required to correct the interference at his own expense.

### 2.3. EMC Compliance (Canada)

The method of compliance is self-declaration to Canadian standard ICES-003:

(English): This Class A digital apparatus complies with the Canadian ICES-003.

(French): Cet appareil numérique de la class A est conforme à la norme NMB-003 du Canada.

## 3/ Shipment and Unpacking

Please check that your package is complete, and contains the items below (according to the ordered unit configuration). If you discover damaged or missing items, please contact your dealer.

### 3.1. Unpacking

Proceed as follows to unpack the unit:

1. Remove packaging.
2. Do not discard the original packaging. Keep it for future relocation.
3. Check the delivery for completeness by comparing it with your order.
4. Please keep the associated paperwork. It contains important information for handling the unit.
5. Check the contents for visible shipping damage.
6. If you notice any shipping damage or inconsistencies between the contents and your order, please contact Kontron for help and information.

### 3.2. Scope of Delivery

#### 3.2.1. Standard

- ▶ 1x RuggedClient-SKL (corresponding to the ordered system configuration)
- ▶ 1x Power adapter (corresponding to the ordered system configuration)
- ▶ 1x Power cord (corresponding to the ordered system configuration)
- ▶ Mounting Clamps with Screws

#### 3.2.2. Optional Parts

- ▶ Memory module(s) (It may be pre-installed in the system depending on ordered configuration.)
- ▶ Internal 2.5" SATA HDD / SSD (It may be pre-installed in the system depending on ordered configuration.)
- ▶ mSATA card (It may be pre-installed in the system depending on ordered configuration.)
- ▶ mPCIe card(s) (It may be pre-installed in the system depending on ordered configuration.)
- ▶ Antenna(s)
- ▶ Riser Card (It may be pre-installed in the system depending on ordered configuration.)
- ▶ VESA mounting kit

## 4/ System Overview

Kontron RuggedClient-SKL integrates an industrial PC with an integrated touch screen display. The rugged design offers excellent mechanical stability for operation in harsh industrial environments.

It can be optionally factory-equipped with an mPCIe WLAN card or an mPCIe 3G / 4G card as well as antenna(s). Users may choose the implementation of a 2.5" SATA HDD / SSD and / or an mSATA SSD card as storage media depending on the ordered system configuration.

The following interfaces are available with the RuggedClient-SKL:

### Standard Rear Panel:

- ▶ 2x DP
- ▶ 1x DVI-D
- ▶ 1x Line-in
- ▶ 1x Line-out
- ▶ 1x Mic-in
- ▶ 2x GbE LAN
- ▶ 4x USB 3.0
- ▶ 2x USB 2.0
- ▶ 3x RS232/422/485
- ▶ 3x RS232
- ▶ 1x DC IN Power Jack or Phoenix Connector
- ▶ 1x Power Switch
- ▶ 2x PCIe x16 Slot (optional, full-length card type support)

### Standard Baseboard and System Expansion Capabilities:

- ▶ 2x 260-pin DDR4 SO-DIMM memory socket (DIMM1 & DIMM2 socket)
- ▶ 1x SATA 3.0 connector (SATA1, 2, 3 or 4 connector) for 2.5" SATA HDD / SSD
- ▶ 1x full-sized mSATA / mPCIe socket (MPCIE2 socket) for mSATA SSD or mPCIe expansion card
- ▶ 1x half-sized mPCIe socket (MPCIE1 socket) for mPCIe expansion card

### The device is designed to be operated in:

- ▶ Vertical position: mounted in an instrument / wall / other cabinet (with the corresponding supplied mounting clamps) or on the wall / VESA stand / VESA pole (with an optional VESA mounting kit)

#### **NOTICE**

When powering on the RuggedClient-SKL, make sure that the air intake and exhaust openings of the chassis are not obstructed (covered) by any objects.

To provide sufficient heat dissipation by the cooling of the device, do not cover the air intake and exhaust openings of the RuggedClient-SKL. When installing the system, please keep clearance for air circulation.

## 4.1. System Expansion Capabilities

### 4.1.1. System Expansion via SATA Interface

The system reserves space allowing users to expand the RuggedClient-SKL with a 2.5" SATA HDD / SSD drive via one of the onboard SATA 3.0 interface connectors.

## 4.1.2. System Expansion via mSATA / mPCIe Card Interface

The baseboard comes with an onboard full-sized mSATA / mPCIe interface connector and an onboard half-sized mPCIe interface connector. The mSATA / mPCIe interface connector can be switched to mSATA or mPCIe setting via the jumper JP4. The connectors are intended to be used to install an mSATA SSD drive and / or mPCIe WLAN card.



---

**If a customer requires 3G / 4G functionality, it must be so stipulated when ordering, as an optional SIM card slot must be installed at the factory.**

**3G / 4G modem adapter card (and SIM card) is functional only with the full-sized mPCIe interface connector.**

---

## 4.1.3. System Expansion via PCIe x16 Slot

The system can optionally come with two PCIe add-on card slots (Figure 1, pos. 14) accessible on the rear I/O panel via an optional riser card. The slots at maximum support full-length card type (312 mm long). Users can easily insert network card(s), SATA controller card(s), graphics card(s) or other functional expansion module(s) for advanced applications. Mechanically, both slots are x16 sized. Electrically, they support either x16 signal among one of the slots or x8 signal among each slot.



---

**If a customer requires PCIe expansion functionality, it must be so stipulated when ordering, as an optional riser card must be installed at the factory in order to adapt the onboard PCIe interface to these two slots.**

**Signal configuration must be stipulated as well when ordering, as it must be switched via the onboard jumper at the factory.**

---

## 4.2. Rear I/O Panel

Figure 1: Rear I/O Panel

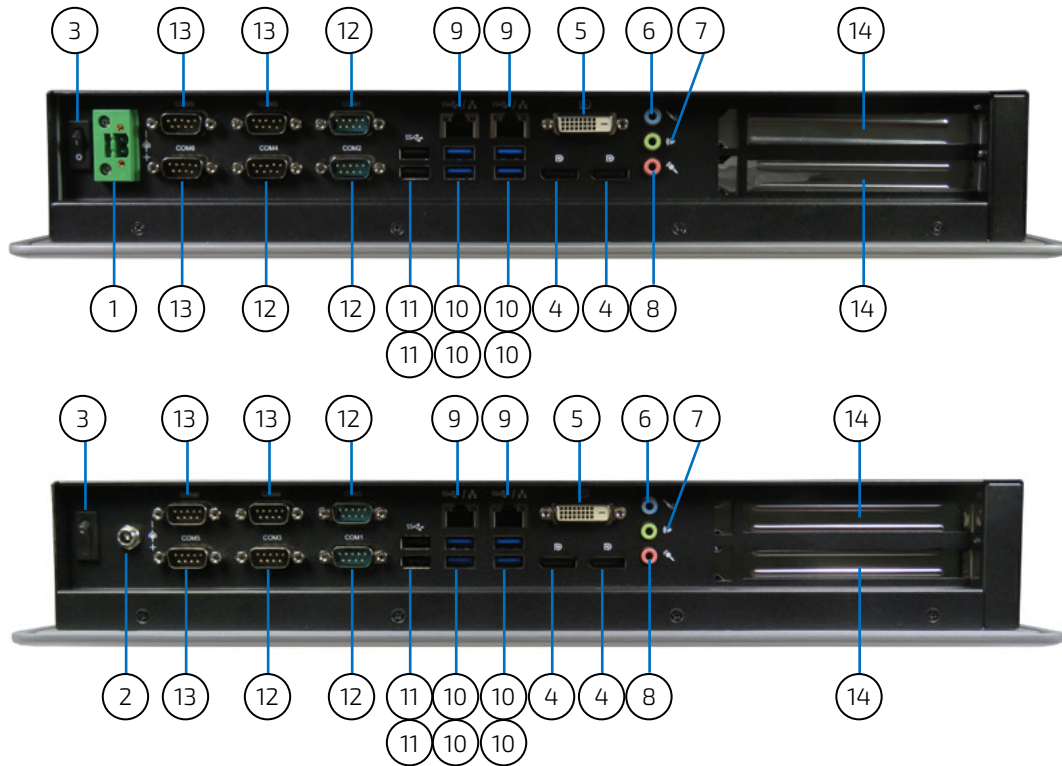

- 1 2-pin Phoenix DC-In Power Connector (see Chapter 4.2.1)
- 2 2.5 mm jack DC-In Power Connector (see Chapter 4.2.2)
- 3 Power Switch (see Chapter 4.2.3)
- 4 DP (see Chapter 4.2.4)
- 5 DVI-D (see Chapter 4.2.5)
- 6 Line-In (see Chapter 4.2.6)
- 7 Line-Out (see Chapter 4.2.7)
- 8 Mic-In (see Chapter 4.2.8)
- 9 GbE (see Chapter 4.2.9)
- 10 USB 3.0 (see Chapter 4.2.10)
- 11 USB 2.0 (see Chapter 4.2.11)
- 12 RS232/422/485 (see Chapter 4.2.12)
- 13 RS232 (see Chapter 4.2.13)
- 14 PCIe x16 Slot (see Chapter 4.2.14)

### 4.2.1. 2-pin Phoenix DC-In Power Connector

The supplied power adapter converts AC power to DC for use with this 2-pin Phoenix connector. Power supplied through this connector supplies power to the PC. To prevent damage to the PC, always use the supplied power adapter.

### 4.2.2. 2.5 mm Jack DC-In Power Connector

The supplied power adapter converts AC power to DC for use with this jack with 2.5 mm inside contact diameter. Power supplied through this jack supplies power to the PC. To prevent damage to the PC, always use the supplied power adapter.

### 4.2.3. Power Switch

Press this switch to turn the system on or off.

#### **⚠ WARNING**

---

Even when the system is turned off via the power switch there is still a standby voltage on the baseboard. The unit is only completely disconnected from the DC mains, when the power is removed.

---

### 4.2.4. DP

The RuggedClient-SKL provides two DP connectors. Two external (digital) display can be connected to these DP connectors.

### 4.2.5. DVI-D

The RuggedClient-SKL provides one DVI-D (Digital Video Interface Digital) connector. One external (digital) display can be connected to this DVI-D connector.

### 4.2.6. Line-In

The Line-in jack is designed to take input from a higher-powered sound source.

### 4.2.7. Line-Out

The stereo headphone jack is used to connect the system's audio out signal to amplified speakers or headphones.

### 4.2.8. Mic-In

The microphone jack is designed to connect the microphone used for video conferencing, voice narrations, or simple audio recordings.

### 4.2.9. GbE

These connectors are Gigabit Ethernet 10/100/1000 Mbit/s, IEEE 1588 capable interfaces. The connectors are standard 8-pin RJ45 type connectors with status LEDs:

Figure 2: Ethernet LED Status

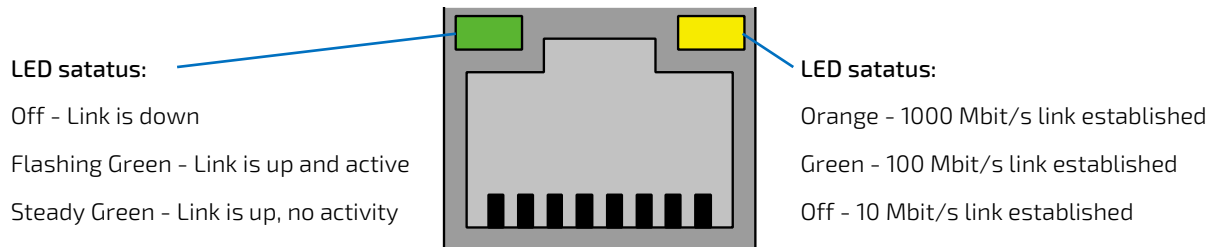

### 4.2.10. USB 3.0

The RuggedClient-SKL provides four USB 3.0 / 2.0 interface. These connectors allow connection of USB 3.0 or USB 2.0 compatible device to the system.

### 4.2.11. USB 2.0

The RuggedClient-SKL provides two USB 2.0 / 1.1 interfaces. These connectors allow connection of USB-compatible devices to the system.

### 4.2.12. RS232/422/485

COM 1, COM 2 and COM 3 are provided as a 9-pin D-SUB connector and allow the connection of a serial peripheral. They are designed to support RS232/422/485 serial communication which can be configured via BIOS setup.

### 4.2.13. RS232

COM 4, COM 5 and COM 6 are provided as a 9-pin D-SUB connector and allow the connection of a serial peripheral. They are designed to support RS232 serial communication.

### 4.2.14. PCIe x16 Add-on Card Slot (Optionally)

The RuggedClient-SKL optionally provides two PCIe x16 add-on card slots accessible on the rear I/O panel for network, storage, graphics, video or other functional expansion. Both slots have enough space to accommodate the full length (312 mm long) card. They supports either x16 signal among one of the slots or x8 signal among each slot.

Figure 3: Maximum Length for PCIe Add-on Card

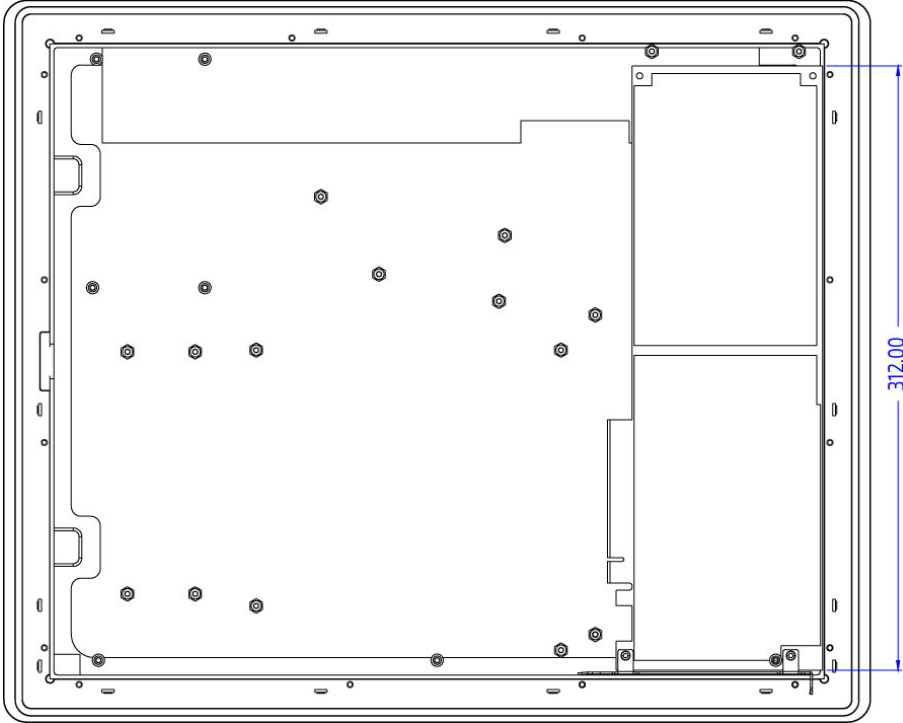

## 4.3. Top I/O Panel

Figure 4: Top I/O Panel

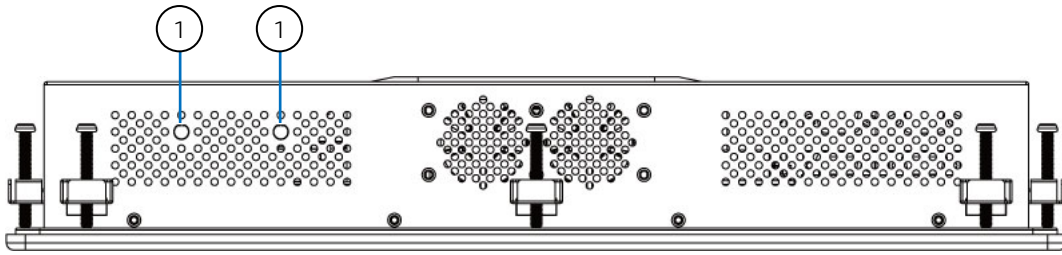

- 1 Antenna Port (see Chapter 4.3.1)

### 4.3.1. Antenna

The RuggedClient-SKL reserves two covered cutouts for the Reverse Polarity (RP) SMA connectors of two WLAN antennas (mPCIe WLAN card with two antennas is an option).

## 5/ Thermal Considerations

### 5.1. Available Processors

Please refer to the chapter 9/ "Technical Specifications".



---

The list of processors may be extended over the product lifetime.

---

### 5.2. Convection Cooling

The applied cooling method provides adequate cooling of the device during operation. The air intakes and exhaust openings located on the rear and three sides of the chassis provide air circulation for the system interior cooling, in order to prevent overheating.



---

To provide sufficient heat dissipation for the cooling of the RuggedClient-SKL, never cover the air openings of the chassis.

---

### 5.3. System Clearance

To provide a maximum of airflow through the rear side of the device, proper distances to the rear side must be observed.

### 5.4. Maximum Temperatures



---

The maximum system ambient temperature depends mostly on the power consumption of the processor and the chipset.

---

For the temperature evaluation a specialised tool from Intel® was used to set the processor to a defined workload. Depending on the power consumption one or more cores were set to 75% workload. This includes the graphics core. The tool also handles the usage of the "Turbo Mode" of certain processor types.



---

The processor utilization depends highly on the software used. Software using multicore feature will run on several cores whereas standard software will only utilize one core. In this case the processor will use the "Turbo Mode" to increase the clock for the core with the highest workload, as long as the temperature is within limits.

---

### 5.5. Third Party Components

When the RuggedClient-SKL is extended and configured with third party components like mPCIe expansion card and hard drives (HDD or SSD), it has to be taken into account that the air temperature inside the system is higher than the ambient temperature. An approximately internal temperature rise is given for assistance.

## 6/ Installation Instructions

The RuggedClient-SKL system is designed for operating:

- ▶ in an instrument / wall / other cabinet by use of the corresponding supplied mounting clamps
- ▶ onto a wall / VESA stand / VESA pole by use of a VESA mounting kit.

### **NOTICE**

---

Whenever possible, unpack or pack this product only at EOS/ESD safe work stations. Where a safe work station is not guaranteed, it is important for the user to be electrically discharged before touching the product with his/her hands or tools. This is most easily done by touching a metal part of the system chassis.

Do not handle this product out of its protective enclosure while it is not used for operational purposes unless it is otherwise protected.

Prior any installation work, ensure that there are no live wires on the installation site.

Do not handle the device if there is any damage visible.

Do not operate the RuggedClient-SKL with foreign objects inside the chassis.

Further do not insert any retrieval device into the device while it is connected to power.

Kontron rejects all liability for any and all damages resulting from operation of the unit with foreign objects inside the chassis.

The RuggedClient-SKL has to be installed and operated only by trained and qualified personnel.

Only personnel with appropriate qualifications, trainings and authorization are permitted to install and work with the Kontron RuggedClient-SKL.

This device shall only be installed in or connected to systems that fulfill all necessary technical and specific environmental requirements.

The unit must be placed such that there is sufficient space in rear of it for connecting the cables to the I/O interface connectors and for operating the power button.

Leave sufficient free space around the unit to prevent the device from possibly overheating!

The RuggedClient-SKL must be firmly attached to a clean flat and solid mounting surface. Use proper fastening materials suitable for the mounting surface. Ensure that the mounting surface type and the used mounting solution safely support the load of the RuggedClient-SKL and the attached components.

Please follow the local/national regulations for grounding.

The voltage feeds must not be overloaded. Adjust the cabling and the overcurrent protection to correspond with the electrical figures indicated on the type label.

The type label is located on the rear side of the system.

It is recommended that the last cable attached to the system should be the power cable! Refer to the section 6.2 "DC Power Connection" and chapter 7/ "Starting Up".

---

## 6.1. System Mounting

In order to adapt the RuggedClient-SKL for mounting Kontron offers different mounting solution such as:

- ▶ Panel mount: RuggedClient-SKL configuration with the corresponding supplied mounting clamps for vertical installation into an instrument / wall / other cabinet
- ▶ VESA mount: RuggedClient-SKL configuration with a VESA mounting kit for vertical installation onto a wall / VESA stand / VESA pole

### 6.1.1. System Mounting by Use of the Mounting Clamps

Depending on the ordered RuggedClient-SKL configuration, your system is supplied with a number of the corresponding mounting clamps (Figure 6) sufficient to mount the system into an instrument / wall / other cabinet.

Figure 5: Mounting clamp



Table 1: Specification for mounting by use of the mounting clamps

Model	19" Model
Cut-out for mounting to a wall / panel (W x H) [mm]	416 x 346 mm (16.38" x 13.62")
Thickness for the mounting wall / panel for proper mounting [mm]	1.5 ~ 6
Number of the clamps with screws for mounting to a wall / panel	9 (3 for top /right / left side respectively)
Required tool	Phillips screwdriver

#### NOTICE

In order to ensure IP65 front sealing against dust and water, *mount the system on a non-textured surface.*

Before you install the RuggedClient-SKL into a panel or a wall, verify the perfect condition of the gasket at the rear of the front bezel.

The gasket has to be in place without surface imperfections / defects and dirt.

Ensure the vertical and horizontal alignment of the system.

#### WARNING

The screen of the RuggedClient-SKL is fragile. Handle with care to prevent personal injury or material damage. Always use two hands when carrying the device.

The screen of the RuggedClient-SKL is provided with a protective film. Only remove this protective material after the installation of the RuggedClient-SKL.

To mount the system to a wall or to a panel, please proceed according to the steps described:

1. Depending on the dimension of your RuggedClient-SKL, prepare a cutout in the wall / panel. The maximum thickness of the wall / panel is 6 mm. Refer to Table 1 and Figure 5 for the wall / panel cutout dimensions or to Figure 12 for the corresponding mechanical drawings of your RuggedClient-SKL.
2. The system must be properly powered down and disconnected from the power source and peripherals.
3. The wall / panel where you intend to install the system must be accessible from both sides (front as well as rear). The material strength and stiffness must be sufficient to hold the system unit.
4. Insert the system into the wall / panel cutout front the front as shown in Figure 5.

Figure 6: Insert the system into the cutout

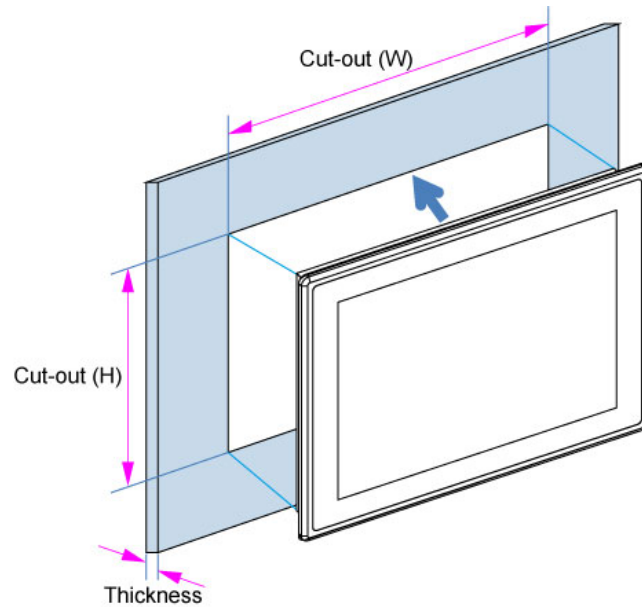

5. In order to ensure the protection class IP65 on the front side in the installed condition, the contact surface with the gasket must be clean and flush.
6. Remove the mounting opening covers from the chassis with Phillips screwdriver. The number of mounting openings (Table 1) varies depending on the ordered RuggedClient-SKL configuration.
7. Hook the mounting clamps with screws (Figure 4) from the rear side of the wall / panel into the corresponding mounting openings as shown in Figure 6.

Figure 7: Hook mounting clamps into mounting openings

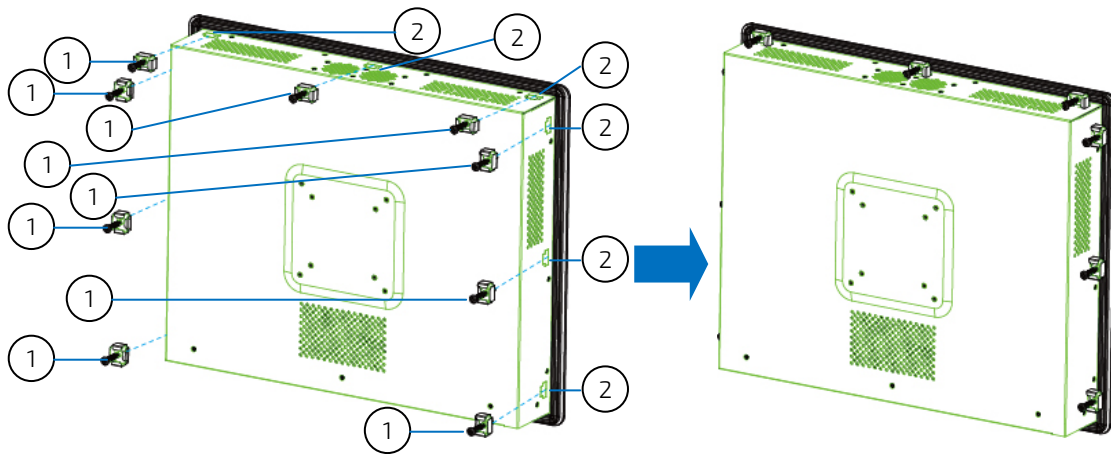

- 1 Mounting Clamp with Screw
- 2 Mounting Opening with Cover (Remove the cover before hooking the mounting clamp into it.)

8. The system must be attached firmly by tightening the screws. Always tighten screws on the opposite side of the front panel.

### 6.1.2. System Mounting by Use of a VESA Mounting Kit

The RuggedClient-SKL comes with VESA FDMI 75 / 100 standard mounting holes (Figure 7).

Figure 8: VESA mounting hole locations

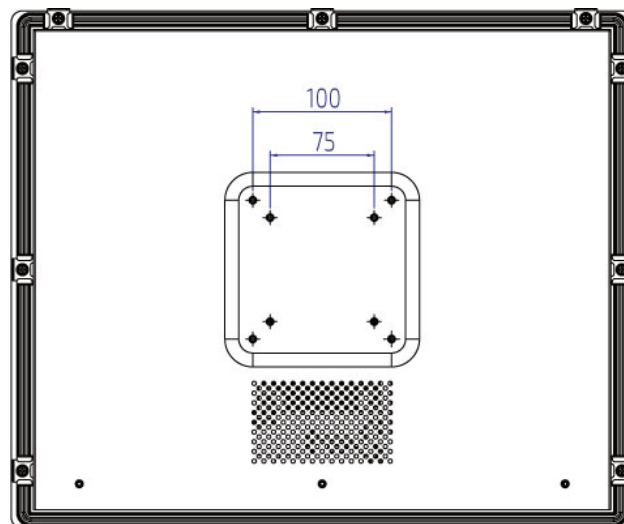

Depending on the ordered RuggedClient-SKL configuration, your system may be supplied with a VESA mounting kit (Figure 8). The kit consists of two parts: a base bracket (Figure 8, pos. 1) to be fixed permanently on the mounting surface and another hooked bracket to hold the RuggedClient-SKL with a hand-screw knob (Figure 8, pos. 2) to secure two brackets.

Figure 9: Optional VESA mounting kit



- 1 Base mounting bracket
- 2 Hooked mounting bracket with a hand-screw knob

To mount the RuggedClient-SKL please proceed according to the steps described:

1. Prepare the mounting surface with sufficient screws (six screws for base mounting bracket) and if necessary anchors corresponding to the mounting surface type if no screw holes are available.
2. Secure the base mounting bracket to the mounting surface with screws (Figure 9).

Figure 10: Secure the base mounting bracket

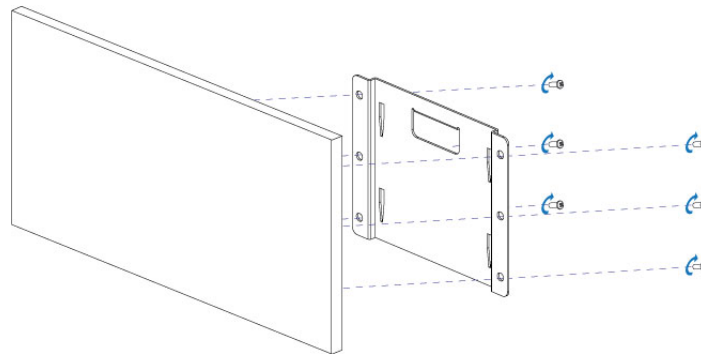

3. Secure the hooked mounting bracket onto the rear side of the RuggedClient-SKL (Figure 10).

Figure 11: Secure the hooked mounting bracket onto the RuggedClient-SKL

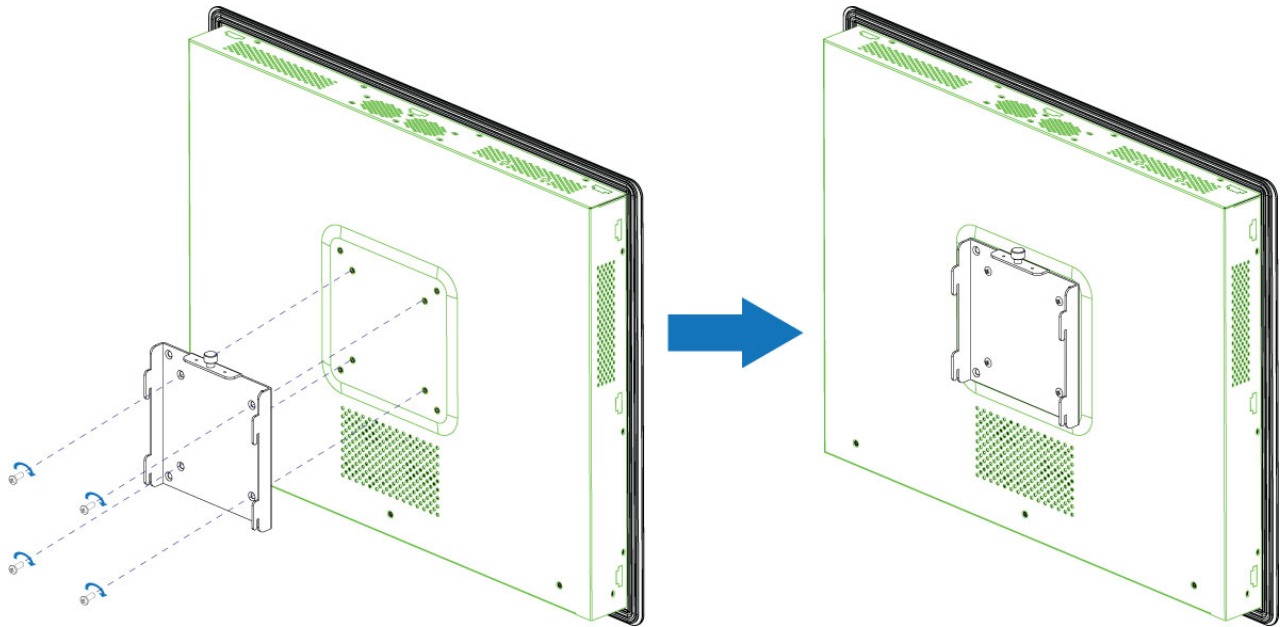

4. Place the RuggedClient-SKL onto the mounting surface by sliding the hooked mounting bracket into the based mounting bracket (Figure 11).
5. Secure the hand-screw knob located on the hooked mounting bracket to fix two brackets (Figure 11).

Figure 12: Secure the RuggedClient-SKL onto the mounting surface

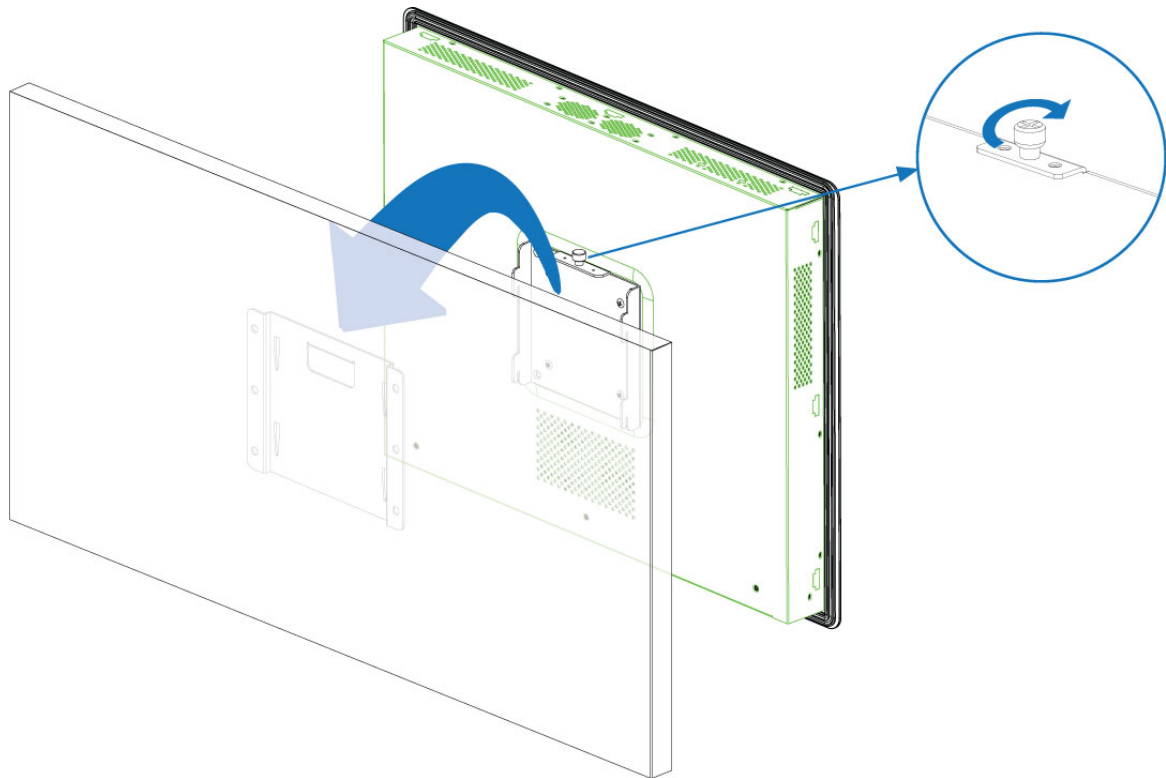

## 6.2. DC Power Connection

Depending on the ordered configuration, the RuggedClient-SKL is connected by a Phoenix connector via a DC power supply wiring (Figure 1, pos. 1, only the Phoenix power plug terminal is included) or a DC power input jack (Figure 1, pos. 2) to a DC power source.

The RuggedClient-SKL with DC power input jack is delivered with a power adapter to convert AC voltage into DC 19 V, 24 V or other voltage option depending on the ordered configuration and a power cord to carry AC power to the power adapter.

The model with Phoenix connector is delivered with a DC power plug terminal (2-pin Phoenix connector). For DC connection, prepare the connecting wires using the supplied Phoenix plug terminal.

Figure 13: Phoenix power plug terminal

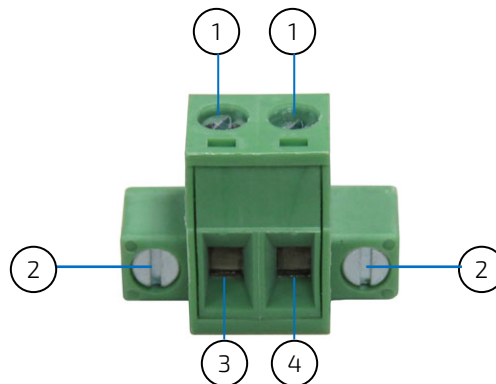

- 1 Slotted pan head screw for securing the wire
- 2 Slotted pan head screw for securing the Phoenix plug terminal to the Phoenix connector
- 3 Location for inserting the positive (+) input wire
- 4 Location for inserting the negative (-) input wire

### 6.2.1. Cabling

For the pin assignment Phoenix power plug terminal refer to the subsection 10.1.1 "Power Input Connector".

1. Cut the required length two isolated wires ( 1mm<sup>2</sup>) AWG 18 and strip each end 5 ~ 7 mm.
2. Twist the striped wire-ends and provide them with ferrules.
3. Loosen the two slotted pan head screws of the DC plug terminal far enough so that you can insert the end of the prepared wires.
4. Insert the wires into the corresponding clamp of the Phoenix plug terminal. Make sure that you have the right polarity of the connection [refer to Figure 12 or subsection 10.1.1 "Power Input Connector"].
5. Fasten the screws to secure the wires into the clamps of the plug terminal.

## 7/ Starting Up



---

The RuggedClient-SKL must be only operated with the nominal voltage of 19V DC, 24V DC or other voltage option of type SELV depending on the ordered configuration. For details refer to the chapter 9/ "Technical Specifications".

---

### 7.1. Connecting to DC Power Supply

The Phoenix connector (Figure 1, pos. 1) or DC power input jack (Figure 1, pos. 2) is located on the rear side of the RuggedClient-SKL. The RuggedClient-SKL will be connected to a AC-to-DC power adapter via the supplied Phoenix power plug terminal or male DC power plug as well as corresponding power cable attached to the adapter.



---

Before using your system, become familiar with the system components and check that everything is connected properly. Following a proper cabling procedure will prevent a false power-on condition, which could result in unit operational failure.

When you install/disconnect the unit, the functional earth connection must always be made first and disconnected last.

Also, it is recommended that the last connections attached to the system should be the power wires!

---

#### NOTICE

---

The RuggedClient-SKL must be connected DC power supply complying with the SELV (Safety Extra Low Voltage) requirements of EN 60950-1 standard. It must be observed that wiring and short-circuit/overcurrent protection is performed according to the applicable standards, regulations and respect to the electrical specification of the RuggedClient-SKL.

Even when the system is turned off via the power switch (Figure 1, pos. 3) parts of the system are still energized.

The disconnecting device (fuse/circuit breaker) rating must be in accordance with the wire cross-section and the rated current of the RuggedClient-SKL.

---



---

The cables must have some form of support so as to minimize the strain on the unit's connectors.

---

To connect the RuggedClient-SKL to a corresponding DC power supply, please perform the following steps:

1. Connect the power adapter cable to DC IN via the Phoenix connector (Figure 1, pos. 1) or the DC power input jack (Figure 1, pos. 2) of the RuggedClient-SKL.
2. Connect the power cable to the power adapter.
3. Connect the power cable to a power outlet.
4. Press the power switch (Figure 1, pos. 3) on the rear panel to turn on the system.

## 7.2. Operating System and Hardware Component Drivers

Your system can be supplied optionally with a pre-installed operating system.

If you have ordered your RuggedClient-SKL with a pre-installed operating system, all drivers are installed in accordance with the system configuration ordered (optional hardware components). Your system is fully operational when you switch it on for the first time. Please pay attention to the following note.



---

**Important information on the use of the pre-installed "WINDOWS 7 ULTIMATE FOR EMBEDDED SYSTEMS" or "WINDOWS 7 PROFESSIONAL FOR EMBEDDED SYSTEMS" operating systems:**

The terms and conditions for the use of the pre-installed operating systems are specified in the document "MICROSOFT SOFTWARE LICENSE TERMS".

You can download this document from our web site [www.kontron.com](http://www.kontron.com) by selecting **Product/ Downloads tab/Windows**.

---

If you have ordered the RuggedClient-SKL without a pre-installed operating system, you will need to install the operating system and the appropriate drivers for the system configuration you have ordered (optional hardware components) yourself.



---

You can download the relevant drivers for the installed hardware from our web site at [www.kontron.com](http://www.kontron.com) by selecting the product.

Pay attention to the manufacturer specifications of the operating system and the integrated hardware components.

---



---

Latest Linux Distribution and Kernel shall be used in order to properly support the Skylake graphics engine.

---

## 8/ Maintenance and Cleaning

Kontron systems require minimal maintenance and care to keep operation correctly.

- ▶ Occasionally wipe the RuggedClient with a soft dry microfiber cloth.
- ▶ You should only remove persistent dirt by use of a soft, slightly damp cloth and mild detergent.

### 8.1. Touch Screen Care and Cleaning

**NOTICE**

---

The touch screen is covered by an anti-glare surface finish and care should be taken when cleaning it. The front side of the touch display unit is sealed against dust and liquids.

---

The touch screen is protected by an anti-glare surface finish. Care should be taken to avoid using sharp objects such as knife, pen or pencil tips. Sharp objects may permanently damage the surface of the anti-glare surface finish.

Mild detergent and water is recommended for cleaning the touch screen. Use of strong solvents must be avoided. Wet the display surface with a microfiber cloth lightly moistened with warm water and mild glass cleaner.

### 8.2. Replacing the Lithium Battery

**NOTICE**

---

The lithium battery is located on the baseboard and is not a serviceable part. Please contact Kontron support if the lithium battery needs to be replaced.

---

## 9/ Technical Specifications

Table 2: Technical Specifications

<b>System</b>		
<b>Processor</b>	6th Gen Intel® Core™ / Celeron® S-Series Processors (FCLGA1151 Socket, up to 35 W TDP)	
<b>Chipset</b>	Intel® Q170	
<b>Memory</b>	2x DDR4 SO-DIMM memory socket	
<b>Video</b>		
<b>Display</b>	<b>Size</b>	19"
	<b>Ratio</b>	5:4
	<b>Backlight</b>	LED
	<b>Resolution</b>	1280 x 1024 SXGA
	<b>Touch</b>	5-wire Resistive
<b>Display Interface</b>	2x DP (on rear) 1x DVI-D (on rear)	
<b>Multiple Display</b>	▶ Triple	
<b>Audio</b>		
<b>Audio Codec</b>	Realtek ALC662	
<b>Audio Interface</b>	▶ 1x Line-in (on rear) ▶ 1x Line-out (on rear) ▶ 1x Mic-in (on rear)	
<b>Network Connection</b>		
<b>Ethernet</b>	2x GbE LAN (RJ45 on rear, 1x Intel® I219-LM, 1x Intel® I210-AT)	
<b>Peripheral Connection</b>		
<b>USB</b>	▶ 4x USB 3.0 (Type A on rear) ▶ 2x USB 2.0 (Type A on rear)	
<b>Serial Port</b>	▶ 3x RS232/422/485 (DB9 on rear) ▶ 3x RS232 (DB9 on rear)	
<b>Storage &amp; Expansion</b>		
<b>Storage &amp; Expansion</b>	▶ 1x 2.5" SATA HDD / SSD ▶ 1x mSATA / mPCIe (full size) ▶ 1x mPCIe (half size) ▶ 2x PCIe x16 slot (on rear, full length, optional, one x16 (default) or two x8 signal support) ▶ 1x SIM Card Cage (optional)	
<b>Power</b>		
<b>Input Voltage</b>	DC 19 V (default), 24 V or other options (by request)	
<b>Connector</b>	Phoenix Connector (on rear) or Lockable DC Jack (on rear)	
<b>Power Adapter</b>	AC 100 V ~ 240 V	
<b>Firmware</b>		
<b>BIOS</b>	AMI uEFI BIOS w/ 128 Mb SPI Flash	
<b>Watchdog</b>	Programmable WDT to generate system reset event	
<b>H/W Monitor</b>	Input & Core Voltages, CPU & System Temperatures	

<b>Real Time Clock</b>	Chipset integrated RTC
<b>TPM</b>	Supported (Infineon SLB 9660 TPM 1.2)
<b>iAMT</b>	Depending on processor
<b>System Control &amp; Monitoring</b>	
<b>Button, Switch &amp; Indicator</b>	1x Power Switch (on rear)
<b>Cooling</b>	
<b>Cooling Method</b>	Active
<b>Software</b>	
<b>OS Support</b>	Windows 7, Windows 8, Windows 10, Linux

## 9.1. Mechanical Specifications

Table 3: Mechanical Specifications

<b>Construction</b>	Metal Chassis + Aluminum Front Bezel
<b>Dimensions (W x H x D)</b>	448 mm x 373 mm x 72.5 mm (17.64" x 14.69" x 2.85")
<b>Weight</b>	7650 g (16.87 lb)
<b>Mounting</b>	Panel Mount, VESA Mount

### 9.1.1. Mechanical Drawing

Figure 14: Mechanical Drawing

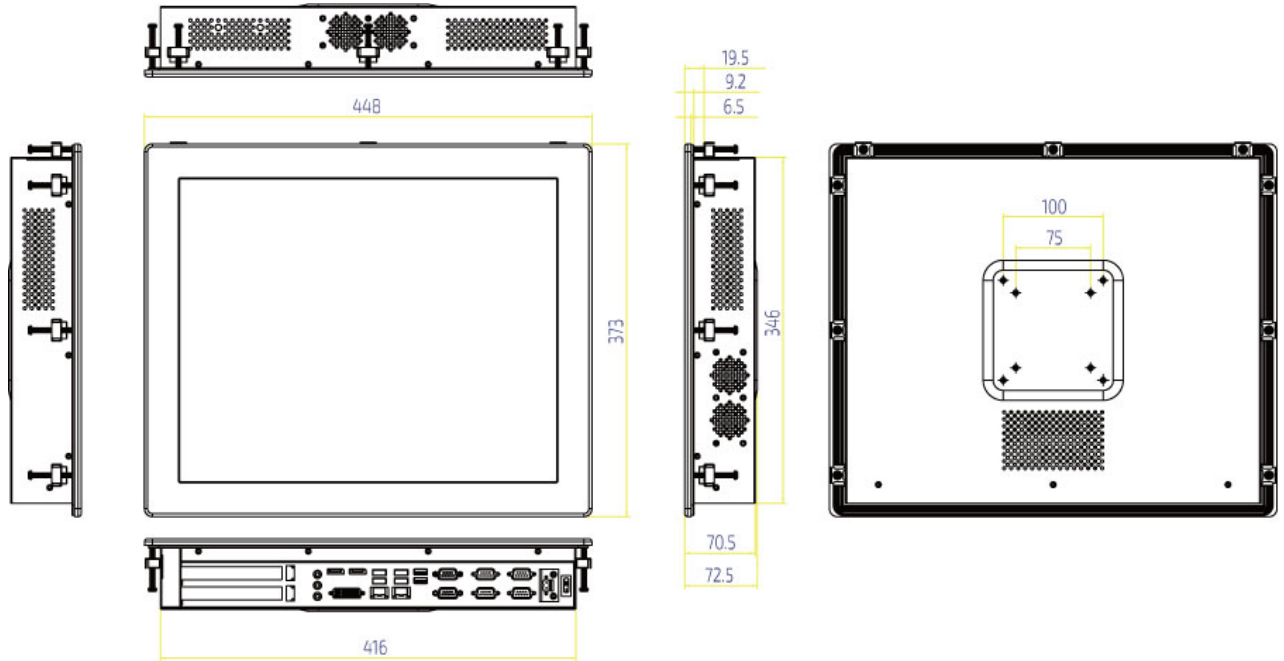

(unit: mm)

### 9.2. Environmental Conditions

Table 4: Environmental Conditions

Operating Temperature	0 °C ~ 50 °C / 32 °F ~ 122 °F
Storage Temperature	-20 °C ~ 70 °C / -4 °F ~ 158 °F
Humidity	0 % ~ 95 %

### 9.3. Standards and Certifications

Table 5: Standards and Certifications

CE	<ul style="list-style-type: none"> <li>▶ EN 55022: 2010 + AC: 2011 and CISPR 22: 2008 (modified)</li> <li>▶ AS/NZS CISPR 22: 2009 with Amdt 1 (2010) (CISPR 22 Ed. 6.0)</li> <li>▶ EN 61000-3-2: 2014 and IEC 61000-3-2: 2014</li> <li>▶ EN 61000-3-3: 2013 and IEC 61000-3-3: 2013</li> <li>▶ EN 55024: 2010 + A1: 2015 and CISPR 24: 2010 + A1: 2015</li> <li>▶ EN 61000-4-2: 2009 and IEC 61000-4-2: 2008</li> <li>▶ EN 61000-4-3: 2006 + A1: 2008 + A2: 2010 and IEC 61000-4-3: 2006 + A1: 2007 + A2: 2010</li> <li>▶ EN 61000-4-4: 2012 and IEC 61000-4-4: 2012</li> <li>▶ EN 61000-4-5: 2014 and IEC 61000-4-5: 2014</li> <li>▶ EN 61000-4-6: 2014 + AC: 2015 and IEC 61000-4-6: 2013</li> <li>▶ EN 61000-4-8: 2010 and IEC 61000-4-8: 2009</li> <li>▶ EN 61000-4-11: 2004 and IEC 61000-4-11: 2004</li> </ul>
FCC	<ul style="list-style-type: none"> <li>▶ FCC CFR Title 47 Part 15 Subpart B: 2015 - Section 15.107 and 15.109</li> <li>▶ ANSI C63.4-2014</li> <li>▶ ICES-003 Issue 6: 2016 Class A</li> </ul>

## 10/ Standard Interfaces – Pin Assignments

Low-active signals are indicated by a minus sign.

### 10.1.1. Phoenix Connector

Table 6: Phoenix Connector (see Figure 1, pos.1)

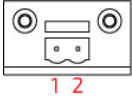
Pin	Signal Name	2-pin Phoenix Connector (female)
1	12VDC (input) (24VDC optional)	
2	0V (input)	

### 10.1.2. DC Jack

Table 7: DC Jack (see Figure 1, pos.2)

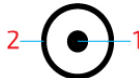
Pin	Signal Name	DC Jack (female)
1	+12Vin (+24Vin optional)	
2	GND	

### 10.1.3. Ethernet Connectors

Table 8: Ethernet Connector (see Figure 1, pos. 9)

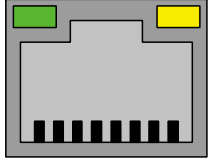
Pin	Signal Name	LAN1, LAN2 (RJ45)
1	TX1+	
2	TX1-	
3	TX2+	
4	TX3+	
5	TX3-	
6	TX2-	
7	TX4+	
8	TX4-	

### 10.1.4. USB 3.0 Port

Table 9: USB 3.0 Port (see Figure 1, pos. 10)

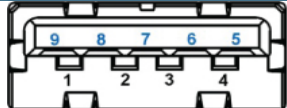
USB 2.0 Contact Pins		USB 3.0 Contact Pins		9-pin USB Connector Type A Version 3.0 / 2.0
Pin	Signal Name	Pin	Signal Name	
1	+USBVCC	5	USB_RX-	
2	USB_D-	6	USB_RX+	
3	USB_D+	7	GND	

USB 2.0 Contact Pins		USB 3.0 Contact Pins		9-pin USB Connector Type A Version 3.0 / 2.0
Pin	Signal Name	Pin	Signal Name	
4	GND	8	USB_TX-	
		9	USB_TX+	

### 10.1.5. USB 2.0 Port

Table 10: USB 2.0 Port (see Figure 1, pos. 11)

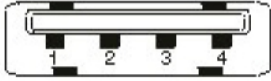
Pin	Signal Name	4-pin USB Connector Type A Version 2.0
1	+USBVCC	
2	USB_D-	
3	USB_D+	
4	GND	

### 10.1.6. DP Connector

Table 11: DP Connector (see Figure 1, pos. 4)

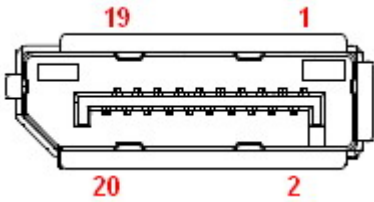
Pin	Signal Name	20-pin DP Connector
1	TX0+	
2	GND	
3	TX0-	
4	TX1+	
5	GND	
6	TX1-	
7	TX2+	
8	GND	
9	TX2-	
10	TX3+	
11	GND	
12	TX3-	
13	GND	
14	GND	
15	AUX+	
16	GND	
17	AUX-	
18	HPD	
19	GND	
20	PWR	

### 10.1.7. DVI-D Connector

Table 12: DVI-D Connector (see Figure 1, pos. 5)

Pin	Signal Name	DVI-D Connector 24+1-pin Female Connector
1	TX2-	
2	TX2+	
3	GND	
4	NC	
5	NC	
6	DDC_CLK	
7	DDC_DATA	
8	NC	
9	TX1-	
10	TX1+	
11	GND	
12	NC	
13	NC	
14	+5V	
15	GND	
16	HT PLG	
17	TX0-	
18	TX0+	
19	GND	
20	NC	
21	NC	
22	GND	
23	TXC+	
24	TXC-	
C	GND	

### 10.1.8. RS232/422/485 Serial Port

Table 13: RS232/422/485 Serial Port (see Figure 1, pos. 12)

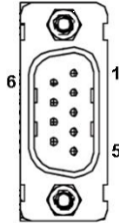
Pin	RS232	RS422	RS485 Half Duplex	RS485 Full Duplex	COM1, COM2, COM3 (9-pin D-SUB Male Connector)
1	DCD	TX-	DATA-	TX-	
2	RXD	TX+	DATA+	TX+	
3	TXD	RX+	N/A	RX+	
4	DTR	RX-	N/A	RX-	
5	GND	GND	GND	GND	
6	DSR	N/A	N/A	N/A	
7	RTS	N/A	N/A	N/A	
8	CTS	N/A	N/A	N/A	
9	RI	N/A	N/A	N/A	

### 10.1.9. RS232 Serial Port

Table 14: RS232 Serial Port (see Figure 1, pos. 13)

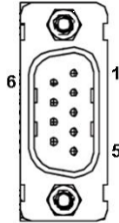
Pin	Signal Name	COM4, COM5, COM6 (9-pin D-SUB Male Connector)
1	DCD	
2	RXD	
3	TXD	
4	DTR	
5	GND	
6	DSR	
7	RTS	
8	CTS	
9	RI	

### 10.1.10. Line-In Connector

Table 15: Line-In Connector (see Figure 1, pos. 6)

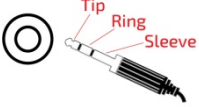
Pin	Signal Name	Line-In Connector & Corresponding Audio Jack
Tip	Line-In_L	
Ring	Line-In_R	
Sleeve	GND	

### 10.1.11. Line-Out Connector

Table 16: Line-Out Connector (see Figure 1, pos. 7)

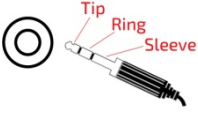
Pin	Signal Name	Line-Out Connector & Corresponding Audio Jack
Tip	Line-Out_L	
Ring	Line-Out_R	
Sleeve	GND	

### 10.1.12. Mic-In Connector

Table 17: Mic-In Connector (see Figure 1, pos. 8)

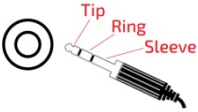
Pin	Signal Name	Mic-In Connector & Corresponding Audio Jack
Tip	Mic-In_L	
Ring	Mic-In_R	
Sleeve	GND	

## 11/ uEFI BIOS

### 11.1. Starting the uEFI BIOS

The RuggedClient-SKL is provided with a Kontron-customized, pre-installed and configured version of AMI Aptio® V uEFI BIOS. AMI BIOS firmware is based on the Unified Extensible Firmware Interface (uEFI) specification and the Intel® Platform Innovation Framework for EFI. This uEFI BIOS provides a variety of new and enhanced functions specifically tailored to the hardware features of the RuggedClient-SKL.



**The BIOS version covered in this document might not be the latest version. The latest version might have certain differences to the BIOS options and features described in this chapter.**

The uEFI BIOS comes with a setup program that provides quick and easy access to the individual function settings for control or modification of the uEFI BIOS configuration. The setup program allows the accessing of various menus that provide functions or access to sub-menus with more specific functions of their own.

To start the uEFI BIOS setup program, follow the steps below:

1. Power on the board.
2. Wait until the first characters appear on the screen (POST messages or splash screen).
3. Press the <DEL> key.
4. If the uEFI BIOS is password-protected, a request for password will appear. Enter either the User Password or the Supervisor Password (see Security menu), press <RETURN>, and proceed with step 5.
5. A setup menu will appear.

The RuggedClient-SKL uEFI BIOS setup program uses a hot key-based navigation system. A hot key legend bar is located on the bottom of the setup screens.

The following table provides information concerning the usage of these hot keys.

**Table 18: Navigation Hot Keys Available in the Legend Bar**

Hotkeys	Description
<F1>	The <F1> key invokes the General Help window.
<->	The <Minus> key selects the next lower value within a field.
<+>	The <Plus> key selects the next higher value within a field.
<F2>	The <F2> key loads the previous values.
<F3>	The <F3> key loads the standard default values.
<F4>	The <F4> key saves the current settings and exit the uEFI BIOS setup.
<=> or <=<=>	The <Left/Right> arrows selects major setup menus on the menu bar. For example: Main, Advanced, Security, etc.
<↑> or <↓>	The <Up/Down> arrows selects fields in the current menu. For example: A setup function or a sub-screen.
<ESC>	The <ESC> key exits a major setup menu and enter the Exit setup menu. Pressing the <ESC> key in a sub-menu displays the next higher menu level.
<RERURN>	The <RETURN> key executes a command or select a submenu.

## 11.2. Setup Menus

The Setup utility features shows six menus in the selection bar at the top of the screen:

- ▶ Main
- ▶ Advanced
- ▶ Power
- ▶ Security
- ▶ Boot
- ▶ Save & Exit

The Setup menus are selected via the left and right arrow keys. The currently active menu and the currently active uEFI BIOS Setup item are highlighted in white. Each Setup menu provides two main frames. The left frame displays all available functions. Functions that can be configured are displayed in blue. Functions displayed in gray provide information about the status or the operational configuration. The right frame displays an Item Specific Help window providing an explanation of the respective function.

### 11.2.1. Main Setup Menu

Upon entering the uEFI BIOS Setup program, the Main Setup menu is displayed. This screen lists the Main Setup menu sub-screens and provides basic system information. Additionally functions for setting the system time and date are offered.

**Table 19: Main Setup Menu Sub-Screens and Functions**

Function	Description
BIOS Information	Read only field. Displays information about the system BIOS
Memory Information	Read only field. Displays information about total memory
ME Information	Read only field. Displays information about Intel Management Engine (ME) version
Firmware Information	Code version and firmware information
System Date	Set System Date
System Time	Set System Time

Figure 15: BIOS Main Menu Screen System Data and Time

BIOS SETUP UTILITY					
Main	Advanced	Power	Security	Boot	Save & Exit
Product Information					
Product Name		RuggedClient-SKLQ-190-R			
BIOS Version		R 0.01 (x64)			
BIOS Build Date		11/29/2016			
ME FW Version		11.0.0.1178			
CPU Information					
Intel® Core™ i7-6700TE CPU @ 2.40GHz					
Microcode Revision		39			
Processor Cores		4			
Memory Information					
Total Size		8192 MB			
Frequency		2133 MHz			
System Date		[Fri 11/25/2016]			
System Time		[14:17:17]			
Access Level		Administrator			
→ ←: Select Screen ↑ ↓: Select Item Enter: Select +/-: Change Opt. F1: General Help F2: Previous Values F3: Optimized Defaults F4: Save & Exit ESC: Exit					
Version 2.17.1254. Copyright (C) 2016, American Megatrends, Inc.					

Feature	Option	Description
System Date	[dd/mm/yyyy]	Set the Date. Use Tab to switch between Data elements.
System Time	[hh:mm:ss]	Set the Time. Use Tab to switch between Time elements.

## 11.2.2. Advanced Setup Menu

The Advanced setup menu provides sub-screens and functions for advanced configurations. The following sub-screen functions are included in the menu:

- ▶ LAN & Audio Configuration
- ▶ Display Configuration
- ▶ Super IO Configuration
- ▶ CPU Chipset Configuration
- ▶ SATA Configuration
- ▶ USB Configuration
- ▶ AMT Configuration
- ▶ Network Stack
- ▶ H/W Monitor

---

**NOTICE**

Setting items on this screen to incorrect values may cause the system to malfunction.

---

Figure 16: BIOS Advanced Menu

BIOS SETUP UTILITY					
Main	Advanced	Power	Security	Boot	Save & Exit
Onboard LAN1 Controller		[Enabled]			
Onboard LAN2 Controller		[Enabled]			
Audio Controller		[Enabled]			
> Display Configuration				→ ←: Select Screen	
> Super IO Configuration				↑ ↓: Select Item	
> CPU Chipset Configuration				Enter: Select	
> SATA Configuration				+/-: Change Opt.	
> USB Configuration				F1: General Help	
> AMT Configuration				F2: Previous Values	
> Network Stack				F3: Optimized Defaults	
> H/W Monitor				F4: Save & Exit	
				ESC: Exit	
Version 2.17.1254. Copyright (C) 2016, American Megatrends, Inc.					

Feature	Option	Description
Onboard LAN1 Controller	[Disabled], [Enabled]	Select whether to enable or disable Onboard LAN1 Controller.
Onboard LAN2 Controller	[Disabled], [Enabled]	Select whether to enable or disable Onboard LAN2 Controller.
Audio Controller	[Disabled], [Enabled]	Select whether to enable or disable Audio Controller.

Figure 17: BIOS Advanced Menu - Display Configuration

BIOS SETUP UTILITY					
Main	Advanced	Power	Security	Boot	Save & Exit
Display Configuration					
Primary Display		[Auto]		→ ←: Select Screen	
UWA Frame Buffer Size		[256MB]		↑ ↓: Select Item	
DVMT Pre-Allocated		[64MB]		Enter: Select	
DVMT Total Gfx Mem		[256MB]		+/-: Change Opt.	
Active LVDS		[Enabled]		F1: General Help	
LVDS Panel Type		[1280x1024 24Bit 2CH]		F2: Previous Values	
LVDS Backlight Control - PWM		127		F3: Optimized Defaults	
				F4: Save & Exit	
				ESC: Exit	
Version 2.17.1254. Copyright (C) 2016, American Megatrends, Inc.					

Feature	Option	Description
Primary Display	[Auto], [IGFX], [PEG], [PCIE]	Select which graphic controller to be used as the primary display device.
UWA Frame Buffer Size	[128MB], [256MB], [512MB]	Select the Aperture Size.
DVMT Pre-Allocated	[32M], [64M], [96M], [128M], [160M], [192M], [224M], [256M], [288M], [320M], [352M], [384M], [416M], [448M], [480M], [512M], [1024M]	Select DVMT Pre-Allocated (Fixed) Graphics Memory size used by the Internal Graphics Device.
DVMT Total Gfx Mem	[128M], [256M], [MAX]	Select DVMT Total Graphic Memory size used by the Internal Graphics Device.
Active LVDS	[Disabled], [Enabled]	Select Active LVDS Configuration. [Disabled]: VBIOS does not enable LVDS. [Enabled]: VBIOS will enable LVDS.
LVDS Panel Type	[640x480 18Bit 1CH], [800x480 18Bit 1CH], [800x600 18Bit 1CH], [1024x768 18Bit 1CH], [1440x900 18Bit 2CH], [1600x900 18Bit 2CH], [1024x600 18Bit 1CH], [1366x768 18Bit 1CH], [1024x768 24Bit 1CH], [1280x1024 24Bit 2CH], [1366x768 24Bit 1CH], [1366x768 24Bit 2CH], [1440x900 24Bit 2CH], [1600x1200 24Bit	Select the appropriate setup item for LVDS panel.

Feature	Option	Description
	2CH, [1920x1080 24Bit 2CH], [1920x1200 24Bit 2CH]	

Figure 18: BIOS Advanced Menu - Super IO Configuration

BIOS SETUP UTILITY					
Main	Advanced	Power	Security	Boot	Save & Exit
Super IO Configuration					
> Serial Port 1 Configuration > Serial Port 2 Configuration > Serial Port 3 Configuration > Serial Port 4 Configuration > Serial Port 5 Configuration > Serial Port 6 Configuration				→ ←: Select Screen ↑ ↓: Select Item Enter: Select +/-: Change Opt. F1: General Help F2: Previous Values F3: Optimized Defaults F4: Save & Exit ESC: Exit	
Version 2.17.1254. Copyright (C) 2016, American Megatrends, Inc.					

Figure 19: BIOS Advanced Menu - Super IO Configuration - Serial Port 1 Configuration

BIOS SETUP UTILITY					
Main	Advanced	Power	Security	Boot	Save & Exit
Serial Port 1 Configuration					
Serial Port		[Enabled]		→ ←: Select Screen ↑ ↓: Select Item Enter: Select +/-: Change Opt. F1: General Help F2: Previous Values F3: Optimized Defaults F4: Save & Exit ESC: Exit	
Device Settings		IO=3F8h; IRQ=4;			
Change Setting		[Auto]			
Serial Port 1 Type		[RS232]			
RS485 Deplx Mode*		[Half Duplex]			
RS485 Auto Flow Control*		[Disabled]			
Version 2.17.1254. Copyright (C) 2016, American Megatrends, Inc.					

\* These items appear only when selecting RS485 for the Serial Port 1 Type.

Feature	Option	Description
Serial Port	[Disabled], [Enabled]	Select whether to enable or disable Serial Port (COM).
Change Settings	[Auto], [IO=3F8h; IRQ=4;], [IO=3F8h; IRQ=3, 4, 5, 6, 7, 9, 10, 11, 12;], [IO=2F8h; IRQ=3, 4, 5, 6, 7, 9, 10, 11, 12;], [IO=3E8h; IRQ=3, 4, 5, 6, 7, 9, 10, 11, 12;], [IO=2E8h; IRQ=3, 4, 5, 6, 7, 9, 10, 11, 12;]	Select an optional setting for Super IO device.

Feature	Option	Description
Serial Port 1 Type	[RS232], [RS422], [RS485]	Select an appropriate type for Serial Port 1.
RS485 Duplex Mode	[Half Duplex], [Full Duplex]	Select an appropriate RS485 Duplex Mode.
RS485 Auto Flow Control	[Disabled], [Enabled]	Select whether to enable or disable RS485 Auto Flow Control

Figure 20: BIOS Advanced Menu - Super IO Configuration - Serial Port 2 Configuration

BIOS SETUP UTILITY					
Main	Advanced	Power	Security	Boot	Save & Exit
Serial Port 2 Configuration					
Serial Port		[Enabled]		→ ←: Select Screen	
Device Settings		IO=2F8h; IRQ=3;		↑ ↓: Select Item	
Change Setting		[Auto]		Enter: Select	
Serial Port 2 Type		[RS232]		+/-: Change Opt.	
RS485 Deplx Mode*		[Half Duplex]		F1: General Help	
RS485 Auto Flow Control*		[Disabled]		F2: Previous Values	
				F3: Optimized Defaults	
				F4: Save & Exit	
				ESC: Exit	
Version 2.17.1254. Copyright (C) 2016, American Megatrends, Inc.					

\* These items appear only when selecting RS485 for the Serial Port 2 Type.

Feature	Option	Description
Serial Port	[Disabled], [Enabled]	Select whether to enable or disable Serial Port (COM).
Change Settings	[Auto], [IO=2F8h; IRQ=3;], [IO=3F8h; IRQ=3, 4, 5, 6, 7, 9, 10, 11, 12;], [IO=2F8h; IRQ=3, 4, 5, 6, 7, 9, 10, 11, 12;], [IO=3E8h; IRQ=3, 4, 5, 6, 7, 9, 10, 11, 12;], [IO=2E8h; IRQ=3, 4, 5, 6, 7, 9, 10, 11, 12;]	Select an optional setting for Super IO device.
Serial Port 2 Type	[RS232], [RS422], [RS485]	Select an appropriate type for Serial Port 2.
RS485 Duplex Mode	[Half Duplex], [Full Duplex]	Select an appropriate RS485 Duplex Mode.
RS485 Auto Flow Control	[Disabled], [Enabled]	Select whether to enable or disable RS485 Auto Flow Control

Figure 21: BIOS Advanced Menu - Super IO Configuration - Serial Port 3 Configuration\*

BIOS SETUP UTILITY					
Main	Advanced	Power	Security	Boot	Save & Exit
Serial Port 3 Configuration					
Serial Port		[Enabled]		→ ←: Select Screen	
Device Settings		IO=3E8h; IRQ=5;		↑ ↓: Select Item	
Change Setting		[Auto]		Enter: Select	
Serial Port 3 Type		[RS232]		+/-: Change Opt.	
RS485 Duplex Mode*		[Half Duplex]		F1: General Help	
RS485 Auto Flow Control*		[Disabled]		F2: Previous Values	
				F3: Optimized Defaults	
				F4: Save & Exit	
				ESC: Exit	
Version 2.17.1254. Copyright (C) 2016, American Megatrends, Inc.					

\* These items appear only when selecting RS485 for the Serial Port 3 Type.

Feature	Option	Description
Serial Port	[Disabled], [Enabled]	Select whether to enable or disable Serial Port (COM).
Change Settings	[Auto], [IO=3E8h; IRQ=7;], [IO=3E8h; IRQ=3, 4, 5, 6, 7, 9, 10, 11, 12;], [IO=2E8h; IRQ=3, 4, 5, 6, 7, 9, 10, 11, 12;], [IO=2F0h; IRQ=3, 4, 5, 6, 7, 9, 10, 11, 12;], [IO=2E0h; IRQ=3, 4, 5, 6, 7, 9, 10, 11, 12;]	Select an optional setting for Super IO device.
Serial Port 3 Type	[RS232], [RS422], [RS485]	Select an appropriate type for Serial Port 3.
RS485 Duplex Mode	[Half Duplex], [Full Duplex]	Select an appropriate RS485 Duplex Mode.
RS485 Auto Flow Control	[Disabled], [Enabled]	Select whether to enable or disable RS485 Auto Flow Control

Figure 22: BIOS Advanced Menu - Super IO Configuration - Serial Port 4 Configuration\*

BIOS SETUP UTILITY					
Main	Advanced	Power	Security	Boot	Save & Exit
Serial Port 4 Configuration					
Serial Port		[Enabled]		→ ←: Select Screen ↑ ↓: Select Item Enter: Select +/-: Change Opt. F1: General Help F2: Previous Values F3: Optimized Defaults F4: Save & Exit ESC: Exit	
Device Settings		IO=2E8h; IRQ=5;			
Change Setting		[Auto]			
Version 2.17.1254. Copyright (C) 2016, American Megatrends, Inc.					

Feature	Option	Description
Serial Port	[Disabled], [Enabled]	Select whether to enable or disable Serial Port (COM).
Change Settings	[Auto], [IO=2E8h; IRQ=7;], [IO=3E8h; IRQ=3, 4, 5, 6, 7, 9, 10, 11, 12;], [IO=2E8h; IRQ=3, 4, 5, 6, 7, 9, 10, 11, 12;], [IO=2F0h; IRQ=3, 4, 5, 6, 7, 9, 10, 11, 12;], [IO=2E0h; IRQ=3, 4, 5, 6, 7, 9, 10, 11, 12;]	Select an optional setting for Super IO device.

Figure 23: BIOS Advanced Menu - Super IO Configuration - Serial Port 5 Configuration\*

BIOS SETUP UTILITY					
Main	Advanced	Power	Security	Boot	Save & Exit
Serial Port 5 Configuration					
Serial Port		[Enabled]		→ ←: Select Screen ↑ ↓: Select Item Enter: Select +/-: Change Opt. F1: General Help F2: Previous Values F3: Optimized Defaults F4: Save & Exit ESC: Exit	
Device Settings		IO=2F0h; IRQ=5;			
Change Setting		[Auto]			
Version 2.17.1254. Copyright (C) 2016, American Megatrends, Inc.					

Feature	Option	Description
Serial Port	[Disabled], [Enabled]	Select whether to enable or disable Serial Port (COM).
Change Settings	[Auto], [IO=2F0h; IRQ=5;], [IO=3E8h; IRQ=3, 4, 5, 6, 7, 9, 10, 11, 12;], [IO=2E8h; IRQ=3, 4, 5, 6, 7, 9, 10, 11, 12;], [IO=2F0h; IRQ=3, 4, 5, 6, 7, 9, 10, 11, 12;], [IO=2E0h; IRQ=3, 4, 5, 6, 7, 9, 10, 11, 12;]	Select an optional setting for Super IO device.

Figure 24: BIOS Advanced Menu - Super IO Configuration - Serial Port 6 Configuration\*

BIOS SETUP UTILITY					
Main	Advanced	Power	Security	Boot	Save & Exit
Serial Port 6 Configuration					
Serial Port		[Enabled]		→ ←: Select Screen ↑ ↓: Select Item Enter: Select +/-: Change Opt. F1: General Help F2: Previous Values F3: Optimized Defaults F4: Save & Exit ESC: Exit	
Device Settings		IO=2E0h; IRQ=5;			
Change Setting		[Auto]			
Version 2.17.1254. Copyright (C) 2016, American Megatrends, Inc.					

Feature	Option	Description
Serial Port	[Disabled], [Enabled]	Select whether to enable or disable Serial Port (COM).
Change Settings	[Auto], [IO=2E0h; IRQ=5;], [IO=3E8h; IRQ=3, 4, 5, 6, 7, 9, 10, 11, 12;], [IO=2E8h; IRQ=3, 4, 5, 6, 7, 9, 10, 11, 12;], [IO=2F0h; IRQ=3, 4, 5, 6, 7, 9, 10, 11, 12;], [IO=2E0h; IRQ=3, 4, 5, 6, 7, 9, 10, 11, 12;]	Select an optional setting for Super IO device.

Figure 25: BIOS Advanced Menu - CPU Chipset Configuration

BIOS SETUP UTILITY					
Main	Advanced	Power	Security	Boot	Save & Exit
CPU Chipset Configuration					
EIST		[Enabled]		→ ←: Select Screen	
Turbo Mode		[Enabled]		↑ ↓: Select Item	
Hyper-threading		[Enabled]		Enter: Select	
VT-d		[Enabled]		+/-: Change Opt.	
Active Processor Cores		[All]		F1: General Help	
Limit CPUID Maximum		[Disabled]		F2: Previous Values	
Execute Disable Bit		[Enabled]		F3: Optimized Defaults	
Intel Virtualization Technology		[Disabled]		F4: Save & Exit	
Intel TXT(LT) Support		[Disabled]		ESC: Exit	
Version 2.17.1254. Copyright (C) 2016, American Megatrends, Inc.					

Feature	Option	Description
EIST	[Disabled], [Enabled]	Select whether to enable or disable Enhanced Intel SpeedStep Technology.
Turbo Mode	[Disabled], [Enabled]	Select whether to enable or disable turbo mode.
Hyper-threading	[Disabled], [Enabled]	Select whether to enable or disable Hyper-threading technology. [Enabled] for Windows XP and Linux (OS optimized for Hyper-Threading Technology). [Disabled] for other OS (OS not optimized for Hyper-Threading Technology).
VT-d	[Disabled], [Enabled]	Select whether to enable or disable VT-d capability.
Active Processor Cores	[All], [1], [2], [3]	Select the number of cores to enable in each processor package.
Limit CPUID Maximum	[Disabled], [Enabled]	Select whether to limit CPUID maximum value.
Execute Disable Bit	[Disabled], [Enabled]	Select whether to enable or disable Execute Disable Bit functionality, which prevents malicious buffer overflow attacks..
Intel Virtualization Technology	[Disabled], [Enabled]	Select whether to enable or disable Intel Virtualization Technology.
Intel TXT(LT) Support	[Disabled], [Enabled]	Select whether to enable or disable Intel TXT(LT) support.

Figure 26: BIOS Advanced Menu - SATA Configuration

BIOS SETUP UTILITY					
Main	Advanced	Power	Security	Boot	Save & Exit
SATA Configuration					
SATA Controller(s)		[Enabled]			
SATA Mode Selection		[AHCI]			
Serial ATA Port 1		Empty			
Port 1		[Enabled]			
Serial ATA Port 2		Empty			
Port 2		[Enabled]		→ ←: Select Screen	
Serial ATA Port 3		Empty		↑ ↓: Select Item	
Port 3		[Enabled]		Enter: Select	
Serial ATA Port 4		Empty		+/-: Change Opt.	
Port 5		[Enabled]		F1: General Help	
mSATA Port 1		Empty		F2: Previous Values	
Port 1		[Enabled]		F3: Optimized Defaults	
mSATA Port 2		Empty		F4: Save & Exit	
Port 2		[Enabled]		ESC: Exit	
Version 2.17.1254. Copyright (C) 2016, American Megatrends, Inc.					

Feature	Option	Description
SATA Controller(s)	[Enabled], [Disabled]	Select whether to enable or disable SATA Device.
SATA Mode Selection	[AHCI], [RAID]	Determine how SATA controller(s) operate.
Port 1..4	[Disabled], [Enabled]	Select whether to enable or disable SATA Port 1..4 / mSATA 1..2.

Figure 27: BIOS Advanced Menu - USB Configuration

BIOS SETUP UTILITY					
Main	Advanced	Power	Security	Boot	Save & Exit
USB Configuration					
USB Devices: 1 Keyboard, 1 Mouse, 1 Point				→ ←: Select Screen ↑ ↓: Select Item Enter: Select	
Legacy USB Support		[Enabled]		+/-: Change Opt.	
XHCI Hand-off		[Disabled]		F1: General Help	
USB Mass Storage Driver Support		[Enabled]		F2: Previous Values	
				F3: Optimized Defaults	
				F4: Save & Exit	
				ESC: Exit	
Version 2.17.1254. Copyright (C) 2016, American Megatrends, Inc.					

Feature	Option	Description
Legacy USB Support	[Enabled], [Disabled]	Select whether to enable or disable Legacy USB support. AUTO option disables legacy support if no USB devices are connected.
XHCI Hand-off	[Enabled], [Disabled]	Select whether to enable or disable XHCI Hand-off function. This is a workaround for OSeS without XHCI hand-off support. The XHCI ownership change should be claimed by XHCI driver.
USB Mass Storage Driver Support	[Disabled], [Enabled]	Select whether to enable or disable USB Mass Storage Driver Support.

Figure 28: BIOS Advanced Menu - AMT Configuration

BIOS SETUP UTILITY					
Main	Advanced	Power	Security	Boot	Save & Exit
AMT Configuration					
Intel AMT		[Enabled]		→ ←: Select Screen ↑ ↓: Select Item Enter: Select +/-: Change Opt. F1: General Help F2: Previous Values F3: Optimized Defaults F4: Save & Exit ESC: Exit	
Un-Configure ME		[Disabled]			
Version 2.17.1254. Copyright (C) 2016, American Megatrends, Inc.					

Feature	Option	Description
Intel AMT	[Disabled], [Enabled]	Select whether to enable or disable Intel AMT (Active Management Technology).
Un-Configure ME	[Disabled], [Enabled]	Select whether to enable or disable un-configure ME (Management Engine).

Figure 29: BIOS Advanced Menu - Network Stack

BIOS SETUP UTILITY					
Main	Advanced	Power	Security	Boot	Save & Exit
Network Stack		[Disabled]			
Ipv4 PXE Support*		[Disabled]			
Ipv6 PXE Support*		[Disabled]			
				→ ←: Select Screen	
				↑ ↓: Select Item	
				Enter: Select	
				+/-: Change Opt.	
				F1: General Help	
				F2: Previous Values	
				F3: Optimized Defaults	
				F4: Save & Exit	
				ESC: Exit	
Version 2.17.1254. Copyright (C) 2016, American Megatrends, Inc.					

\* These items appear only when enabling Network Stack.

Feature	Option	Description
Network Stack	[Disabled], [Enabled]	Select whether to enable or disable network stack.
Ipv4 PXE Support	[Disabled], [Enabled]	Select whether to enable or disable Ipv4 PXE Support.
Ipv6 PXE Support	[Disabled], [Enabled]	Select whether to enable or disable Ipv6 PXE Support.

Figure 30: BIOS Advanced Menu - H/W Monitor

BIOS SETUP UTILITY					
Main	Advanced	Power	Security	Boot	Save & Exit
PC Health Status					
CPU Warning Temperature		[Disabled]			
CPU Temperature		: +56 C			
System Temperature		: +47 C			
CPU Fan Speed		: 1323 RPM			
SYS Fan Speed		: N/A			
+V CORE		: +0.957 V			
+VIN		: +18.432 V			
+5V		: +5.106 V			
+VMEN		: +1.221 V			
+3.3VSB		: +3.296 V			
+3.3V		: +3.360 V			
+VRTC		: +3.216 V			
+1.05V		: +1.080 V			
				→ ←: Select Screen ↑ ↓: Select Item Enter: Select +/-: Change Opt. F1: General Help F2: Previous Values F3: Optimized Defaults F4: Save & Exit ESC: Exit	
Version 2.17.1254. Copyright (C) 2016, American Megatrends, Inc.					

Feature	Option	Description
CPU Warning Temperature	[Disabled], [80 C], [85 C], [90 C], [95 C]	Determine whether to enable or disable CPU Warning Temperature function and select a temperature that will sound an alarm.

### 11.2.3. Power Setup Menu

The Power setup menu provides functions and a sub-screen for power configurations. The following sub-screen function is included in the menu:

- ▶ WatchDog Timer Configuration

Figure 31: BIOS Power Setup Menu

BIOS SETUP UTILITY					
Main	Advanced	Power	Security	Boot	Save & Exit
Power Configuration					
ACPI Sleep State		[S3 (Suspend to RAM)]			
Restore AC Power Loss		[Power Off]			
Power Saving Mode		[Disabled]			
Resume Event Control				→ ←: Select Screen	
Resume from S3 By PS/2 Keyboard		[Disabled]		↑ ↓: Select Item	
Resume from S3 By PS/2 Mouse		[Disabled]		Enter: Select	
Resume By LAN Device		[Disabled]		+/-: Change Opt.	
Resume By PCI-E Device		[Disabled]		F1: General Help	
Resume By Ring Device		[Disabled]		F2: Previous Values	
Resume By RTC Alarm		[Disabled]		F3: Optimized Defaults	
> WatchDog Timer Configuration				F4: Save & Exit	
				ESC: Exit	
Version 2.17.1254. Copyright (C) 2016, American Megatrends, Inc.					

Feature	Option	Description
ACPI Sleep State	[Suspend Disabled], [S3 (Suspend to RAM)]	Select whether to enable or disable suspend function and determine an appropriate suspend mode.
Restore AC Power Loss	[Power Off], [Power On], [Last State]	Control whether the system will stay on after AC power is removed and then restored. Select [Power Off] if you want the system to remain off after power restored. Select [Power On] if you use a power strip to turn the system on.
Power Saving Mode	[Disabled], [EUP Enabled]	Select whether to enable Power Saving Mode.
Resume from S3 By PS/2 Keyboard	[Disabled], [Enabled]	Select whether to allow waking the system up from the S3 sleep state by PS/2 keyboard.
Resume from S3 By PS/2 Mouse	[Disabled], [Enabled]	Select whether to allow waking the system up from the S3 sleep state by PS/2 mouse.
Resume By LAN Device	[Disabled], [Enabled]	Select whether to enable or disable Wake from LAN Device.
Resume By PCI-E Device	[Disabled], [Enabled]	Select whether to enable or disable Wake from PCIe Device.
Resume By Ring	[Disabled], [Enabled]	Select whether to enable or disable Wake from Ring Device.

Feature	Option	Description
Device		
Resume By RTC Alarm	[Disabled], [Enabled]	Select whether to enable or disable Wake Up on Alarm, to turn on your system on a special day of the month.

Figure 32: BIOS Power Setup Menu - WatchDog Timer Configuration

BIOS SETUP UTILITY					
Main	Advanced	Power	Security	Boot	Save & Exit
WatchDog Timer Configuration					
WDT Function			[Disabled]	→ ←: Select Screen ↑ ↓: Select Item Enter: Select +/-: Change Opt. F1: General Help F2: Previous Values F3: Optimized Defaults F4: Save & Exit ESC: Exit	
Version 2.17.1254. Copyright (C) 2016, American Megatrends, Inc.					

Feature	Option	Description
WDT Function	[Disabled], [Enabled]	Select whether to enable or disable WatchDog Timer function.

## 11.2.4. Security Setup Menu

The Security setup menu provides information about the passwords and functions for specifying the security settings. The passwords are case-sensitive. The RuggedClient-SKL provides no factory-set passwords.

### NOTICE

If there is already a password installed, the system asks for this first. To clear a password, simply enter nothing and acknowledge by pressing <RETURN>. To set a password, enter it twice and acknowledge by pressing <RETURN>.

Figure 33: BIOS Security Setup Menu

BIOS SETUP UTILITY					
Main	Advanced	Power	Security	Boot	Save & Exit
Password Description					
If ONLY the Administrator's password is set, then this only limits access to Setup and is only asked for when entering Setup					
If ONLY the User's password is set, then this is a power on password and must be entered to boot or enter Setup. In Setup the User will have Administrator rights					
The password length must be in the following range:				→ ←: Select Screen	
Minimum Length		3		↑ ↓: Select Item	
Maximum length		20		Enter: Select	
Administrator Password				+/-: Change Opt.	
User Password				F1: General Help	
				F2: Previous Values	
				F3: Optimized Defaults	
				F4: Save & Exit	
				ESC: Exit	
Version 2.17.1254. Copyright (C) 2016, American Megatrends, Inc.					

Feature	Description
Administrator Password	Set administrator password
User Password	Set user password



If only the administrator's password is set, then only access to setup is limited. The password is only entered when entering setup.

If only the user's password is set, then the password is a power on password and must be entered to boot or enter setup. Within the setup menu the user has administrator rights.

Password length requirements are maximum 20 characters and minimum 3 characters.

### 11.2.4.1. Remember the password

It is highly recommended to keep a record of all passwords in a safe place. Forgotten passwords results in being locked out of the system.

If the system cannot be booted because the User Password or the Supervisor Password are not know, contact Kontron Support for further assistance.



---

**HDD security passwords cannot be cleared using the above method.**

---

## 11.2.5. Boot Setup Menu

The boot setup menu lists the for boot device priority order, that is generated dynamically.

Figure 34: BIOS Boot Setup Menu

BIOS SETUP UTILITY					
Main	Advanced	Power	Security	Boot	Save & Exit
Boot Configuration					
Full Screen LOGO Display		[Disabled]			
Setup Prompt Timeout		1		→ ←: Select Screen	
Bootup NumLock State		[On]		↑ ↓: Select Item	
CSM Support		[Enabled]		Enter: Select	
Boot Option Filter		[UEFI only]		+/-: Change Opt.	
Boot Option Priorities				F1: General Help	
				F2: Previous Values	
				F3: Optimized Defaults	
				F4: Save & Exit	
				ESC: Exit	
Version 2.17.1254. Copyright (C) 2016, American Megatrends, Inc.					

Feature	Option	Description
Full Screen LOGO Display	[Disabled], [Enabled]	Select whether to enable or disable to display logo screen.
Bootup NumLock State	[On], [Off]	Select the state of the NumLock feature of the keyboard after Startup. [On]: The keys on the keypad will act as numeric keys. [Off]: The keys on the keypad will act as cursor keys.
CSM Support	[Enabled], [Disabled]	Select whether to enable or disable CSM support.
Boot Option Filter	[UEFI and Legacy], [Legacy only], [UEFI only]	Control Legacy / UEFI ROMs priority.

## 11.2.6. Save & Exit Setup Menu

The exit setup menu provides functions for handling changes made to the UEFI BIOS settings and the exiting of the setup program.

Figure 35: BIOS Save & Exit Setup Menu

BIOS SETUP UTILITY					
Main	Advanced	Power	Security	Boot	Save & Exit
Save Changes and Reset					
Discard Changes and Reset					
Save Options				→ ←: Select Screen	
Save Changes				↑ ↓: Select Item	
Discard Changes				Enter: Select	
Restore Defaults				+/-: Change Opt.	
				F1: General Help	
				F2: Previous Values	
				F3: Optimized Defaults	
				F4: Save & Exit	
				ESC: Exit	
Version 2.17.1254. Copyright (C) 2016, American Megatrends, Inc.					

Feature	Description
Save Changes and Exit	Exit system setup after saving the changes. Once you are finished making your selections, choose this option from the Exit menu to ensure the values you selected are saved to the CMOS RAM. The CMOS RAM is sustained by an onboard backup battery and stays on even when the PC is turned off. When you select this option, a confirmation window appears. Select [Yes] to save changes and exit.
Discard Changes and Exit	Exit system setup without saving any changes. Select this option only if you do not want to save the changes that you made to the Setup program. If you made changes to fields other than system date, system time, and password, the BIOS asks for a confirmation before exiting.
Save Changes	Save changes done so far to any of the setup values. This option allows you to save the selections you made. After selecting this option, a confirmation appears. Select [Yes] to save any changes.
Discard Changes	Discards changes done so far to any of the setup values. This option allows you to discard the selections you made and restore the previously saved values. After selecting this option, a confirmation appears. Select [Yes] to discard any changes and load the previously saved values.
Restore Defaults	Restore Default values for all the setup values. This option allows you to load optimal default values for each of the parameters on the Setup menus, which will provide the best performance settings for your system. The F9 key can be used for this operation.





## About Kontron

Kontron is a global leader in embedded computing technology (ECT). As a part of technology group S&T, Kontron offers a combined portfolio of secure hardware, middleware and services for Internet of Things (IoT) and Industry 4.0 applications. With its standard products and tailor-made solutions based on highly reliable state-of-the-art embedded technologies, Kontron provides secure and innovative applications for a variety of industries. As a result, customers benefit from accelerated time-to-market, reduced total cost of ownership, product longevity and the best fully integrated applications overall. Kontron is a listed company. Its shares are traded in the Prime Standard segment of the Frankfurt Stock Exchange and on other exchanges under the symbol "KBC". For more information, please visit: [www.kontron.com](http://www.kontron.com) / [www.kontron-asia.com](http://www.kontron-asia.com)

---

▼

PRODUCT CONTACT  
POINT

### **KONTRON ASIA INC.**

4F, No. 415, Ti-Ding Blvd.,  
Sec. 2, Neihu District,  
Taipei, Taiwan 114741  
Tel.: + 886 2 2799 2789  
Fax: + 886 2 2799 7399  
[SalesAsia@kontron.com](mailto:SalesAsia@kontron.com)