



KPanel S-RPL-15.6"/21.5"

User Guide Rev. 1.0

Doc. ID 1075-5852

This page has been intentionally left blank

KPanel S-RPL-15.6"/21.5" – User Guide

Disclaimer

Kontron would like to point out that the information contained in this user guide may be subject to alteration, particularly as a result of the constant upgrading of Kontron products. This document does not entail any guarantee on the part of Kontron with respect to technical processes described in the user guide or any product characteristics set out in the user guide. Kontron assumes no responsibility or liability for the use of the described product(s), conveys no license or title under any patent, copyright or mask work rights to these products and makes no representations or warranties that these products are free from patent, copyright or mask work right infringement unless otherwise specified. Applications that are described in this user guide are for illustration purposes only. Kontron makes no representation or warranty that such application will be suitable for the specified use without further testing or modification. Kontron expressly informs the user that this user guide only contains a general description of processes and instructions which may not be applicable in every individual case. In cases of doubt, please contact Kontron.

This user guide is protected by copyright. All rights are reserved by Kontron. No part of this document may be reproduced, transmitted, transcribed, stored in a retrieval system, or translated into any language or computer language, in any form or by any means (electronic, mechanical, photocopying, recording, or otherwise), without the express written permission of Kontron. Kontron points out that the information contained in this user guide is constantly being updated in line with the technical alterations and improvements made by Kontron to the products and thus this user guide only reflects the technical status of the products by Kontron at the time of publishing.

Brand and product names are trademarks or registered trademarks of their respective owners.

©2026 by Kontron Europe GmbH

Kontron Europe GmbH
Gutenbergstraße 2
85737 Ismaning
Germany
www.kontron.com

Intended Use

This device and associated software are not designed, manufactured or intended for use or resale for the operation of nuclear facilities, the navigation, control or communication systems for aircraft or other transportation, air traffic control, life support or life sustaining applications, weapons systems, or any other application in a hazardous environment, or requiring fail-safe performance, or in which the failure of products could lead directly to death, personal injury, or severe physical or environmental damage (collectively, "high risk applications").

You understand and agree that your use of Kontron devices as a component in High Risk Applications is entirely at your own risk. To minimize the risks associated with your products and applications, you should provide adequate design and operating safeguards. You are solely responsible for compliance with all legal, regulatory, safety, and security related requirements concerning your products. You are responsible for ensuring that your systems (and any Kontron hardware or software components incorporated in your systems) meet all applicable requirements. Unless otherwise stated in the product documentation, the Kontron device is not provided with error-tolerance capabilities and cannot therefore be deemed as being engineered, manufactured or set up to be compliant for implementation or for resale as device in High Risk Applications. All application and safety related information in this document (including application descriptions, suggested safety measures, suggested Kontron products, and other materials) is provided for reference only.

NOTICE

You find the most recent version of the "General Safety Instructions" online in the download area of this product.

NOTICE

This product is not intended for use or suited for storage or operation in corrosive environments, in particular under exposure to sulfur and chlorine and their compounds. For information on how to harden electronics and mechanics against these stress conditions, contact Kontron Support.

Revision History

Revision	Brief Description of Changes	Date of Issue	Author
1.0	Initial version	20-Apr-2026	CW

Terms and Conditions

Kontron warrants products in accordance with defined regional warranty periods. For more information about warranty compliance and conformity, and the warranty period in your region, visit www.kontron.com/terms-and-conditions.

Kontron sells products worldwide and declares regional General Terms & Conditions of Sale, and Purchase Order Terms & Conditions. Visit www.kontron.com/terms-and-conditions.

For contact information, refer to the corporate offices contact information on the last page of this user guide or visit our website [CONTACT US](#).

Customer Support

Find Kontron contacts by visiting www.kontron.com/support-and-services.

Customer Service

As a trusted technology innovator and global solutions provider, Kontron extends its embedded market strengths into a services portfolio allowing companies to break the barriers of traditional product lifecycles. Proven product expertise coupled with collaborative and highly-experienced support enables Kontron to provide exceptional peace of mind to build and maintain successful products.

For more details on Kontron's service offerings such as: enhanced repair services, extended warranty, Kontron training academy, and more visit www.kontron.com/support-and-services.

Customer Comments

If you have any difficulties using this user guide, discover an error, or just want to provide some feedback, contact [Kontron support](#). Detail any errors you find. We will correct the errors or problems as soon as possible and post the revised user guide on our website.

Symbols

The following symbols may be used in this user guide



DANGER indicates a hazardous situation which, if not avoided, will result in death or serious injury.



WARNING indicates a hazardous situation which, if not avoided, could result in death or serious injury.



CAUTION indicates a hazardous situation which, if not avoided, may result in minor or moderate injury

ATTENTION indique une situation dangereuse qui, si elle n'est pas évitée, peut entraîner des blessures mineures ou modérées.



NOTICE indicates a property damage message.



Electric Shock!

This symbol and title warn of hazards due to electrical shocks (> 60 V) when touching products or parts of products. Failure to observe the precautions indicated and/or prescribed by the law may endanger your life/health and/or result in damage to your material.



ESD Sensitive Device!

This symbol and title inform that the electronic boards and their components are sensitive to static electricity. Care must therefore be taken during all handling operations and inspections of this product in order to ensure product integrity at all times.



Caution: HOT Surface!

This symbol and title indicate a hot surface that must not be touched until cool.

Attention : Surface CHAUDE !

Ce symbole et ce titre indiquent une surface chaude qui ne doit pas être touchée avant d'avoir refroidi.



Caution: Laser!

This symbol and title inform of the risk of exposure to laser beam and light emitting devices (LEDs) from an electrical device. Eye protection per manufacturer notice shall review before servicing.



High sound pressure!

This symbol and title inform of high sound pressure possible with headphones. There is a risk of hearing damage. Do not listen at high volume levels for long periods of time.



Security

This symbol and title indicate general information and guidelines regarding the product's cyber security to ensure secure installation, operation, maintenance and disposal of the product within the user's end environment.



This symbol indicates general information about the product and the user guide.



This symbol precedes helpful hints and tips for daily use.

For Your Safety

Your new Kontron product was developed and tested carefully to provide all features necessary to ensure its compliance with electrical safety requirements. It was also designed for a long fault-free life. However, the life expectancy of your product can be drastically reduced by improper treatment during unpacking and installation. Therefore, in the interest of your own safety and of the correct operation of your new Kontron product, you are requested to conform with the following guidelines.

High Voltage Safety Instructions

As a precaution and in case of danger, the power connector must be easily accessible. The power connector is the product's main disconnect device.

⚠ CAUTION

Warning

All operations on this product must be carried out by sufficiently skilled personnel only.

⚠ CAUTION



Electric Shock!

Before installing a non hot-swappable Kontron product into a system always ensure that your mains power is switched off. This also applies to the installation of piggybacks. Serious electrical shock hazards can exist during all installation, repair, and maintenance operations on this product. Therefore, always unplug the power cable and any other cables which provide external voltages before performing any work on this product.

Earth ground connection to vehicle's chassis or a central grounding point shall remain connected. The earth ground cable shall be the last cable to be disconnected or the first cable to be connected when performing installation or removal procedures on this product.

Special Handling and Unpacking Instruction

NOTICE



ESD Sensitive Device!

Electronic boards and their components are sensitive to static electricity. Therefore, care must be taken during all handling operations and inspections of this product, in order to ensure product integrity at all times.

⚠ CAUTION

Handling and operation of the product is permitted only for skilled personnel within a work place that is access controlled. Follow the "General Safety Instructions" supplied with the product.

Do not handle this product out of its protective enclosure while it is not used for operational purposes unless it is otherwise protected.

Whenever possible, unpack or pack this product only at EOS/ESD safe work stations. Where a safe work station is not guaranteed, it is important for the user to be electrically discharged before touching the product with his/her hands or tools. This is most easily done by touching a metal part of your system housing.

It is particularly important to observe standard anti-static precautions when changing piggybacks, ROM devices, jumper settings etc. If the product contains batteries for RTC or memory backup, ensure that the product is not placed on conductive surfaces, including anti-static plastics or sponges. They can cause short circuits and damage the batteries or conductive circuits on the product.

Lithium Battery Precautions

If your product is equipped with a lithium battery, take the following precautions when replacing the lithium battery.

⚠ CAUTION

Risk of Explosion if the lithium Battery is replaced by an incorrect Type. Dispose of used lithium batteries according to the instructions.

Risque d'explosion si la pile au lithium est remplacée par une pile de type incorrect.
Éliminez les piles au lithium usagées conformément aux instructions.

General Instructions on Usage

In order to maintain Kontron's product warranty, this product must not be altered or modified in any way. Changes or modifications to the product, that are not explicitly approved by Kontron and described in this user guide or received from Kontron Support as a special handling instruction, will void your warranty.

This product should only be installed in or connected to systems that fulfill all necessary technical and specific environmental requirements. This also applies to the operational temperature range of the specific board version that must not be exceeded. If batteries are present, their temperature restrictions must be taken into account.

In performing all necessary installation and application operations, only follow the instructions supplied by the present user guide.

Keep all the original packaging material for future storage or warranty shipments. If it is necessary to store or ship the product then re-pack it in the same manner as it was delivered.

Special care is necessary when handling or unpacking the product. See Special Handling and Unpacking Instruction.

Quality and Environmental Management

Kontron aims to deliver reliable high-end products designed and built for quality, and aims to comply with environmental laws, regulations, and other environmentally oriented requirements. For more information regarding Kontron's quality and environmental responsibilities, visit [Quality | Kontron](#) and [Material Compliance | Kontron](#).

Table of Contents

Revision History.....	5
Symbols	6
For Your Safety.....	8
High Voltage Safety Instructions	8
Special Handling and Unpacking Instruction	8
Lithium Battery Precautions	9
General Instructions on Usage	9
Quality and Environmental Management	9
Table of Contents	10
List of Tables.....	12
List of Figures	13
1/ Introduction.....	14
2/ General Safety Instructions	15
2.1. Additional Safety Instructions for DC Power Supply Circuits	16
2.2. Instructions générales de sécurité	16
2.3. Electrostatic Discharge (ESD).....	17
2.4. Grounding Methods	18
2.5. Instructions for Lithium Battery	18
3/ Shipment and Unpacking	19
3.1. Packaging.....	19
3.2. Unpacking.....	19
3.3. Scope of Delivery.....	19
3.4. Accessories and Spare Parts	19
3.5. Type Label and Product Identification.....	21
4/ Product Features	22
4.1. Front Features	22
4.1.1. Touch Screen	22
4.1.2. Seal	23
4.2. Rear Cover Features	24
4.2.1. Cable Entry Point	25
4.2.2. USB Ports (option)	25
4.2.3. Power Button (option).....	25
4.2.4. Wi-Fi/BT® and Cellular LTE Antenna (on request)	25
4.3. Internal Components.....	27
4.3.1. Interface Panel.....	28
4.3.2. Ground Stud.....	28
4.3.3. Ethernet Ports (X102, X103)	28
4.3.4. USB 3.2 Gen 2 Ports (X104, X105, X106, X107)	29
4.3.5. DisplayPorts (X108, X109).....	29
4.3.6. Power IN (X101).....	29
4.3.7. Power Button.....	29
4.3.8. Power LED and State LED.....	29
4.4. Expansion Plate	30
4.4.1. Automotive RTC Lithium Battery (option)	30
4.4.2. Dual Serial Port (RS232) (option).....	30
4.4.3. CF Memory Card (option)	30
4.4.4. 2.5" SSD Drive (option)	31
4.4.5. 2.5" SSD Dual M.2 RAID Module (option).....	31
4.4.6. Expansion Plate Options (on request)	31
4.5. Peripheral Devices	32
5/ Order Information	33
6/ Product Specification	34
6.1. Block Diagram.....	34
6.2. Display Specification.....	34
6.3. Hardware Specification	35

6.4. Software Specification	36
6.5. Environmental Specification.....	36
6.6. Power Specification	37
6.6.1. Power Supply Protection Requirements.....	38
6.6.2. Functional Earth Ground Stud	38
6.7. Compliance.....	38
7/ Thermal and Power Management.....	40
7.1. Passive Cooling	40
7.2. Mount Orientation	40
7.3. Minimum Clearance	41
7.4. Maximum Processor Power and Temperature	41
7.5. Power Consumption and Thermal Monitoring.....	41
7.6. Derating TDP Curve	42
7.7. Configuring the Processor TDP.....	42
7.8. Third Party Components.....	42
8/ Mechanical Specification.....	43
8.1. 15.6" Mechanical Dimension.....	44
8.2. 21.5" Mechanical Dimensions	45
9/ Installation.....	46
9.1. Before Installing	46
9.2. Installation Support Arm	47
9.3. Installing VESA (100/75 mm) Stand or Pole	49
10/ Assembly	51
10.1. Before Assembling.....	51
10.2. Opening and Closing for Initial Assembly.....	52
10.3. Assembling the CPU Module Cables.....	53
10.4. Assembling the Removable Expansion Plate Options	54
10.5. Wiring the Mating Power Connector	54
11/ Starting Up.....	56
11.1. Before Starting Up	56
11.2. Starting Up.....	56
12/ Connector Pin Assignment	57
12.1. Power IN Connector (X101).....	57
12.2. 2.5 GbE Ethernet Ports (X102, X103).....	57
12.3. USB 3.2 Gen 2 Ports (X104 - X107)	58
12.4. DisplayPorts (X108, X109)	59
12.5. Rear Cover Connectors.....	60
12.5.1. USB 3.2 Gen 2 Type A Port (option).....	60
12.6. Antenna (on request)	60
12.6.1. Wi-Fi/BT® Antenna (on request).....	61
12.6.2. Cellular LTE Antenna (on request).....	61
12.7. Removable Expansion Plate Connector.....	62
12.7.1. RTC Lithium Battery Connector	62
12.7.2. Automotive RTC Lithium Battery Connector	62
12.7.3. Serial Port Connector.....	62
13/ BIOS	63
13.1. Starting the uEFI BIOS.....	63
13.2. BIOS Update	64
13.3. Setup Menus	64
13.4. Main Setup Menu	65
13.5. Advanced Setup Menu	67
13.6. ChipSet Setup Menu.....	76
13.7. Security Setup Menu	83
13.8. Boot Setup Menu	85
13.9. Save and Exit Setup Menu	86
14/ Maintenance and Prevention.....	87
14.1. Cleaning the KPanel S.....	87

14.1.1. Cleaning the Front	87
14.1.2. Cleaning the Rear Cover	88
14.2. Maintaining the KPanel S	88
14.2.1. Replacing the Standard RTC Lithium Battery.....	90
14.2.2. Replacing the Automotive RTC Battery	91
14.2.3. Replacing the 2.5" SSD.....	92
14.2.4. Replacing the M.2 SSD on the 2.5" SSD Dual M.2 RAID Module	93
15/ Technical Support.....	96
15.1. Returning Defective Merchandise.....	96
16/ Storage and Transportation	97
16.1. Storage	97
16.2. Transportation.....	97
17/ Warranty	98
18/ Disposal	99
18.1. Disposal	99
18.2. WEEE Compliance.....	99
18.3. Data Sanitation	99
18.4. Statement of Memory Volatility.....	101
19/ Cyber Security	103
19.1. Security Defense Strategy	103
Appendix: List of Acronyms.....	104

List of Tables

Table 1: Scope of Delivery	19
Table 2: List of Accessories and Spare Parts	19
Table 3: Glove Type Performance	23
Table 4: STAT and PWR LED Description	29
Table 5: Order Number Information	33
Table 6: Display Specification	34
Table 7: Hardware Specification	35
Table 8: Software Specification.....	36
Table 9: Environmental Specification.....	36
Table 10: Electrical Specification.....	37
Table 11: Compliance	38
Table 12: Processor TDP and Maximum Temperature Values.....	41
Table 13: Mechanical Specification.....	43
Table 14: Power IN Connector Pin Assignment.....	57
Table 15: 2.5 GbE Ethernet Port Pin Assignment.....	57
Table 16: USB 3.2 Gen 2 Type A Port Pin Assignment.....	58
Table 17: DisplayPort Pin Assignment.....	59
Table 18: USB 3.2 Gen 2 Type A Port Pin Assignment.....	60
Table 19: Wi-Fi/BT® Antenna Pin Assignment	61
Table 20: LTE Antenna Pin Assignment	61
Table 21: Standard RTC Lithium Battery Connector Pin Assignment.....	62
Table 22: Automotive RTC Lithium Battery Connector Pin Assignment	62
Table 23: Serial Port (RS232) Connector Pin Assignment	62
Table 24: Navigation Hot Keys	63
Table 25: Advanced Setup Menu Sub-screens	68
Table 26: Chipset Setup Menu Sub-screens.....	76
Table 27: Security Setup Menu Sub-screen	83
Table 28: Boot Setup Menu Sub-screens	85

Table 29: Save and Exit Setup Menu Sub-screens.....	86
Table 30: RAID Jumper Setting.....	93
Table 31: Statement of Memory Volatility for KPanel S-RPL	101

List of Figures

Figure 1: KPanel S-RPL.....	14
Figure 2: Type Label Examples (KPanel S-RPL-15.6" & KPanel S-RPL-21.5")	21
Figure 3: Front Features	22
Figure 4: Rear Cover Features	24
Figure 5: Wi-Fi/BT® and Cellular LTE Connectors and Antenna Type (on request).....	26
Figure 6: Internal Components	27
Figure 7: Interface Panel – KPanel S-RPL.....	28
Figure 8: Peripheral Devices (keyboard, mouse and handle).....	32
Figure 9: Block Diagram KPanel S-RPL.....	34
Figure 10 Vertical Mount Orientation (permitted)	40
Figure 11: TDPs vs Temperature	42
Figure 12: 15.6" Dimension Diagram (mm/inch)	44
Figure 13: 21.5" Dimension Diagram (mm/inch)	45
Figure 14: Support Arm Installation (landscape and portrait)	47
Figure 15: Portrait Adapter and Gasket	48
Figure 16: VESA Arm Installation (landscape and portrait).....	49
Figure 17: VESA Adapter and Gasket	50
Figure 18: Opening and Closing the KPanel S-RPL.....	52
Figure 19: Power IN and Mating Power Connector	54
Figure 20: Main Setup Menu Example	65
Figure 21: Advanced Setup Menu Example	67
Figure 22: Chipset Setup Menu Example	76
Figure 23: Security Setup Menu Example	83
Figure 24: Boot Setup Menu Example.....	85
Figure 25: Save and Exit Setup Menu Example	86
Figure 26: Accessing Internal Components for Maintenance	89
Figure 27: Expansion Plates (standard and with dual COM)	89
Figure 28: Standard RTC Lithium Battery and Battery Extension Cable.....	90
Figure 29: Automotive Battery with Battery Extension Cable and Expansion Plate (standard).....	91
Figure 30: 2.5" SSD and Expansion Plate.....	92
Figure 31: 2.5" SSD Dual M.2 RAID Module and Expansion Plate.....	93
Figure 32: RAID Configuration.....	94

1/Introduction

This user guide describes the KPanel S-RPL series of on-machine industrial HMI monitors known as KPanel S or product within this user guide. This user guide focuses on describing the special features of the KPanel S and how to assemble, install, operate, maintain and dispose of the product properly. New users are recommended to study the instructions within this user guide before switching on the KPanel S.

The KPanel S-RPL with the Intel® Core-I Raptor-Lake (RPL) processor family offers high mechanical flexibility with respect to design with display sizes 15.6" and 21.5". The KPanel S-series is optimized for mounting on support arms or poles and provides Web panel operation with the QIWI Web browser that enables users to display, monitor, and control their applications.

The KPanel S-series is dust and waterproof with IP65 protection, and service-friendly with an easy-clean, anti-glare and scratch-proof front glass. The KPanel S-series is designed for a long life-cycle thanks to carefully selected components from renowned manufacturers.

Figure 1: KPanel S-RPL



2/General Safety Instructions

Please read this passage carefully and take careful note of the instructions, which have been compiled for your safety and to ensure to apply in accordance with intended regulations. If the following general safety instructions are not observed, it could lead to injuries to the operator and/or damage of the product; in cases of non-observance of the instructions Kontron Europe is exempt from accident liability, this also applies during the warranty period.

The product has been built and tested according to the basic safety requirements for low voltage (LVD) applications and has left the manufacturer in safety-related, flawless condition. To maintain this condition and to also ensure safe operation, the operator must not only observe the correct operating conditions for the product but also the following general safety instructions:

- The product must be used as specified in the product documentation, in which the instructions for safety for the product and for the operator are described. These contain guidelines for setting up, installation and assembly, maintenance, transport or storage.
- The on-site electrical installation must meet the requirements of the country's specific local regulations.
- If a power cable comes with the product, only this cable should be used. Do not use an extension cable to connect the product.
- To guarantee that sufficient air circulation is available to cool the product, please ensure that the ventilation openings are not covered or blocked. If a filter mat is provided, this should be cleaned regularly. Do not place the product close to heat sources or damp places. Make sure the product is well ventilated.
- Only connect the product to an external power supply providing the voltage type (AC or DC) and the input power (max. current) specified on the Kontron Product Label and meeting the requirements of the Limited Power Source (LPS) and Power Source (PS2) of UL/IEC 62368-1.
- Only products or parts that meet the requirements for Power Source (PS1) of UL/IEC 62368-1 may be connected to the product's available interfaces (I/O).
- Before opening the product, make sure that the product is disconnected from the mains.
- Switching off the product by its power button does not disconnect it from the mains. Complete disconnection is only possible if the power cable is removed from the wall plug or from the product. Ensure that there is free and easy access to enable disconnection.
- The product may only be opened for the insertion or removal of add-on cards (depending on the configuration of the product). This may only be carried out by qualified operators.
- If extensions are being carried out, the following must be observed:
 - all effective legal regulations and all technical data are adhered to
 - the power consumption of any add-on card does not exceed the specified limitations
 - the current consumption of the product does not exceed the value stated on the product label
- Only original accessories that have been approved by Kontron Europe can be used.
- Please note: safe operation is no longer possible when any of the following applies:
 - the product has visible damages or
 - the product is no longer functioning
 In this case the product must be switched off and it must be ensured that the product can no longer be operated.
- Handling and operation of the product is permitted only for trained personnel within a work place that is access controlled.
- CAUTION: Risk of explosion if the lithium battery is replaced incorrectly (short-circuited, reverse-poled, wrong lithium battery type). Dispose of used lithium batteries according to the manufacturer's instructions.
- This product is not suitable for use in locations where children are likely to be present

2.1. Additional Safety Instructions for DC Power Supply Circuits

- › To guarantee safe operation, please observe that:
 - › the external DC power supply must meet the criteria for LPS and PS2 (UL/IEC 62368-1)
 - › no cables or parts without insulation in electrical circuits with dangerous voltage or power should be touched directly or indirectly
 - › a reliable functional earth connection is provided
 - › a suitable, easily accessible disconnecting device is used in the application (e.g. overcurrent protective device), if the product itself is not disconnect able
 - › a disconnect device, if provided in or as part of the product, shall disconnect both poles simultaneously
 - › interconnecting power circuits of different products cause no electrical hazards
- › A sufficient dimensioning of the power cable wires must be selected – according to the maximum electrical specifications on the product label – as stipulated by EN62368-1 or VDE0100 or EN60204 or UL61010-1 regulations.

For the General Safety Instruction in German or French, visit Kontron's product web page> Downloads> Manuals> General Safety Instructions.

2.2. Instructions générales de sécurité

Veillez lire attentivement ce passage et prendre bonne note des instructions, qui ont été compilées pour votre sécurité et pour assurer une application conforme aux réglementations prévues. Le non-respect des consignes de sécurité générales suivantes peut entraîner des blessures pour l'utilisateur et/ou des dommages pour le produit. En cas de non-respect des consignes, Kontron Europe est exonéré de la responsabilité en cas d'accident, ceci s'applique également pendant la période de garantie.

Le produit a été construit et testé conformément aux exigences de sécurité de base pour les applications basse tension (DBT) et a quitté le fabricant dans un état impeccable en matière de sécurité. Pour maintenir cet état et pour garantir également un fonctionnement sûr, l'opérateur doit non seulement respecter les conditions d'utilisation correctes du produit, mais aussi les consignes de sécurité générales suivantes :

- › Le produit doit être utilisé conformément à la documentation du produit, dans laquelle sont décrites les instructions de sécurité pour le produit et pour l'opérateur. Celles-ci contiennent des directives pour la mise en place, l'installation et le montage, la maintenance, le transport ou le stockage.
- › L'installation électrique sur place doit répondre aux exigences des réglementations locales spécifiques du pays.
- › Si un câble d'alimentation est fourni avec le produit, seul ce câble doit être utilisé. N'utilisez pas de rallonge pour connecter le produit.
- › Afin de garantir une circulation d'air suffisante pour refroidir le produit, veuillez vous assurer que les ouvertures de ventilation ne sont pas couvertes ou obstruées. Si un élément filtrant est fourni, celui-ci doit être nettoyé régulièrement. Ne placez pas le produit à proximité de sources de chaleur ou d'endroits humides. Veillez à ce que le produit soit bien ventilé.
- › Ne connectez le produit qu'à une alimentation externe fournissant le type de tension (AC ou DC) et la puissance d'entrée (courant max.) spécifiés sur le Label Produit Kontron et répondant aux exigences de la source d'alimentation limitée (LPS) et de la source d'alimentation (PS2) de la norme UL/IEC 62368-1 .
- › Seuls les produits ou les pièces qui répondent aux exigences de la source d'alimentation (PS1) de la norme UL/IEC 62368-1 peuvent être connectés aux interfaces (E/S) disponibles du produit.
- › Avant d'ouvrir le produit, assurez-vous qu'il est bien débranché du secteur.
- › Le fait d'éteindre le produit par son bouton de mise en marche ne le déconnecte pas du secteur. Une déconnexion complète n'est possible que si le câble d'alimentation est retiré de la prise murale ou du produit. Veillez à ce que l'accès soit libre et facile pour permettre la déconnexion.
- › Le produit ne peut être ouvert que pour l'insertion ou le retrait de cartes supplémentaires (selon la configuration du produit). Cette opération ne peut être effectuée que par des opérateurs qualifiés.

- Si des extensions sont effectuées, les points suivants doivent être respectés :
 - toutes les réglementations légales en vigueur et toutes les données techniques sont respectées
 - la consommation électrique d'une carte supplémentaire ne dépasse pas les limites spécifiées
 - la consommation actuelle du produit ne dépasse pas la valeur indiquée sur l'étiquette du produit.
- Seuls les accessoires d'origine approuvés par Kontron Europe peuvent être utilisés.
- Veuillez noter que la sécurité des opérations n'est plus possible lorsque l'une des conditions suivantes s'applique.
 - le produit présente des dommages visibles ou
 - le produit ne fonctionne plus. Dans ce cas, le produit doit être éteint et il faut s'assurer que le produit ne puisse plus être utilisé.
- La manipulation et le fonctionnement du produit ne sont autorisés que pour le personnel formé dans un lieu de travail dont l'accès est contrôlé.
- ATTENTION: Risque d'explosion en cas de remplacement incorrect de la pile au lithium (court-circuit, inversion de polarité, mauvais type de pile au lithium). Éliminez les piles au lithium usagées conformément aux instructions du fabricant.
- Ce produit n'est pas adapté à une utilisation dans des endroits où des enfants sont susceptibles d'être présents
- Instructions de sécurité supplémentaires pour les circuits d'alimentation en courant continu
- Pour garantir un fonctionnement sûr, veuillez observer ce qui suit:
 - l'alimentation électrique externe en courant continu doit répondre aux critères des LPS et PS2 (UL/IEC 62368-1)
 - aucun câble ou pièce non isolée dans les circuits électriques ayant une tension ou une puissance dangereuse ne doit être touché directement ou indirectement
 - une connexion à la terre fonctionnelle fiable est fournie
 - un dispositif de déconnexion approprié et facilement accessible est utilisé dans l'application (par exemple, un dispositif de protection contre les surintensités), si le produit lui-même n'est pas en mesure d'être déconnecté.
 - un dispositif de déconnexion, s'il est prévu dans le produit ou s'il en fait partie, doit déconnecter les deux pôles simultanément
 - l'interconnexion des circuits électriques de différents produits ne présente aucun risque électrique
- Un dimensionnement suffisant des fils du câble d'alimentation doit être choisi - en fonction des spécifications électriques maximales figurant sur l'étiquette du produit - comme stipulé par les réglementations EN62368-1 ou VDE0100 ou EN60204 ou UL61010-1.

2.3. Electrostatic Discharge (ESD)

A sudden discharge of electrostatic electricity can destroy static-sensitive devices or micro-circuitry. Therefore, proper packaging and grounding techniques are necessary precautions to prevent damage.

Always take the following precautions:



ESD Sensitive Device!

Keep electrostatic sensitive parts in their containers until they arrive at the ESD-safe workplace. Always be properly grounded when touching a sensitive board, component, or assembly.

For more Information, see the Special Handling and Unpacking Instruction within this user guide and Chapter 2.4: Grounding Methods.

2.4. Grounding Methods

The following measures help to avoid electrostatic damage to the device:

- › Cover workstations with approved antistatic material. Always wear a wrist strap connected to the workplace, as well as properly grounded tools and equipment.
- › Use antistatic mats, heel straps, or air ionizers for more protection.
- › Always handle electrostatically sensitive components by their edge or by their casing.
- › Avoid contact with pins, leads, or circuitry.
- › Switch off power and input signals before inserting and removing connectors or connecting test equipment.
- › Keep the work area free of non-conductive materials such as ordinary plastic assembly aids and styrofoam.
- › Use field service tools such as cutters, screwdrivers, and vacuum cleaners that are conductive.
- › Always place drives and boards with the PCB-assembly-side down on the foam.

2.5. Instructions for Lithium Battery

The KPanel S is equipped with an RTC lithium battery or optional automotive RTC battery. The RTC lithium battery may over time need to be replaced. There is a risk of explosion if the RTC lithium battery or automotive RTC battery is replaced incorrectly (short-circuited, reverse-poled, wrong lithium battery type).

Replace the RTC lithium battery, only with the same type of RTC lithium battery or with a Kontron recommended RTC lithium battery type, see Table 2: List of Accessories.

For instructions on how to replace the RTC Lithium battery, see Chapter 14/: Maintenance and Prevention. After removing the RTC lithium battery, dispose of the RTC lithium battery according to the regulations within your region.

⚠ CAUTION

Danger of Explosion if the lithium battery is incorrectly placed!

- › Replace only with the same or equivalent type recommended by the manufacturer
- › Dispose of used batteries according to the manufacturer's instructions

ATTENTION- Risque d'explosion avec l'échange inadéquat de la batterie!

- › Remplacement seulement par le même ou un type équivalent recommandé par le producteur
- › L'évacuation des batteries usagées conformément à des indications du fabricant

VORSICHT- Explosionsgefahr bei unsachgemäßem Austausch der Batterie!

- › Ersatz nur durch denselben oder einen vom Hersteller empfohlenen gleichwertigen Typ
- › Entsorgung gebrauchter Batterien nach Angaben des Herstellers



An empty RTC lithium battery BIOS does not affect the BIOS settings. However, the system time and date are affected when the RTC lithium battery is empty and must be reconfigured after replacing the battery.



Do not dispose of lithium batteries in general trash collection. Dispose of the lithium battery according to the local regulations dealing with the disposal of these special materials, (e.g. to the collecting points for disposal of batteries).

3/ Shipment and Unpacking

3.1. Packaging

The KPanel S-RPL is packaged together with all parts, in a product specific cardboard package designed to provide adequate protection and absorb shock.

3.2. Unpacking

To unpack the KPanel S perform the following:



1. Remove packaging.
2. Do not discard the original packaging. Keep the original packaging for future transportation or storage.
3. Check the delivery for completeness by comparing the delivery with the original order.
4. Keep the associated paperwork. It contains important information for handling the product.
5. Check the product for visible shipping damage.

If you notice shipping damage or inconsistencies between the contents and the original order, contact your dealer.

3.3. Scope of Delivery

This scope of delivery describes the parts included in your delivery. Check that the delivery is complete and contains the items listed. If damaged or missing items are discovered, contact your dealer.





Table 1: Scope of Delivery

Part	Quantity	Part Description
	1	KPanel S-RPL hardware configured
	1	Mating Power Connector 3-pin Phoenix (PSC 1.5/ 3-F)

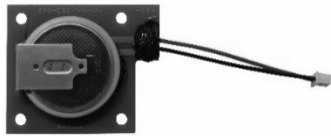
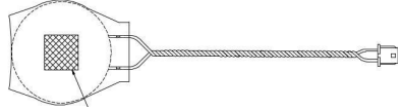
3.4. Accessories and Spare Parts

Table 2: List of Accessories and Spare Parts

Part Number	Part	Part Description
0-0062-3268		3-pin Phoenix power connector (PSC 1.5/ 3-F)
PN01-100006-02		Automotive Battery: Panasonic: BR-2450 A/GAN Nominal Voltage: 3 V Operating Temperature: -40°C up to +125°C
1068-4995		Standard Lithium Battery: Panasonic: BR-2032 Nominal Voltage: 3 V Operating Temperature: -30°C up to +85°C

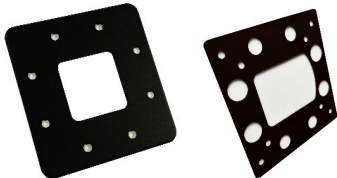
Part Number	Part	Part Description
1080-1485	SET_VK-KIT_KPanel-S- Keyboard_Holder 	Keyboard holder kits including: <ul style="list-style-type: none"> › One keyboard holder › Two L brackets › Four M5x8 Tx screws (bracket to keyboard holder) › Four M3x5 Tx screws (bracket to rear cover) Prerequisite: only installable if the handle (1080-1488) is not installed.
1080-1486	SET_VK-KIT_KPanel-S- Keyboard_Mouse_Holder 	Keyboard and Mouse holder kit including: <ul style="list-style-type: none"> › One keyboard holder › Two L brackets › One mouse holder › Six M5x8 Tx screws (4x bracket to keyboard holder & 2x mouse holder to keyboard holder) › Four M3x5 Tx screws (bracket to rear cover) Prerequisite: Keyboard holder must be installed
1080-1488	SET_VK-KIT_KPanel-S- Handling_Extension 	Handle kit including: <ul style="list-style-type: none"> › One handle › Two brackets (left and right) › Two M8x16MM TX screws (handle to bracket) › Four M5x8 TX screws (bracket to rear cover) Prerequisite: Only installable if the keyboard holder is not installed.
1080-1506	SET_VK-KIT_KPanel-S- Adap._ARM_TO_VESA VESA Adapter Gasket 	VESA Adapter kit including: <ul style="list-style-type: none"> › One VESA adapter (100/75 mm) › One adapter gasket › Four M6 nuts › Four M5x8 Tx screws For VESA (100/75 mm) mounting.
1080-1507	SET_VK-KIT_KPanel-S- Adap._ARM_TO_90° Portrait Adapter Gasket 	Portrait Adapter kit including: <ul style="list-style-type: none"> › One adapter support arm to 90° › One adapter gasket › Four M6 nuts › Four M5x8 Tx screws For Rittal support arm (or compatible support arm), changes the display orientation by 90° (landscape to portrait)

3.5. Type Label and Product Identification

The type label contains specific product identification information and technical information.

Figure 2: Type Label Examples (KPanel S-RPL-15.6" & KPanel S-RPL-21.5")

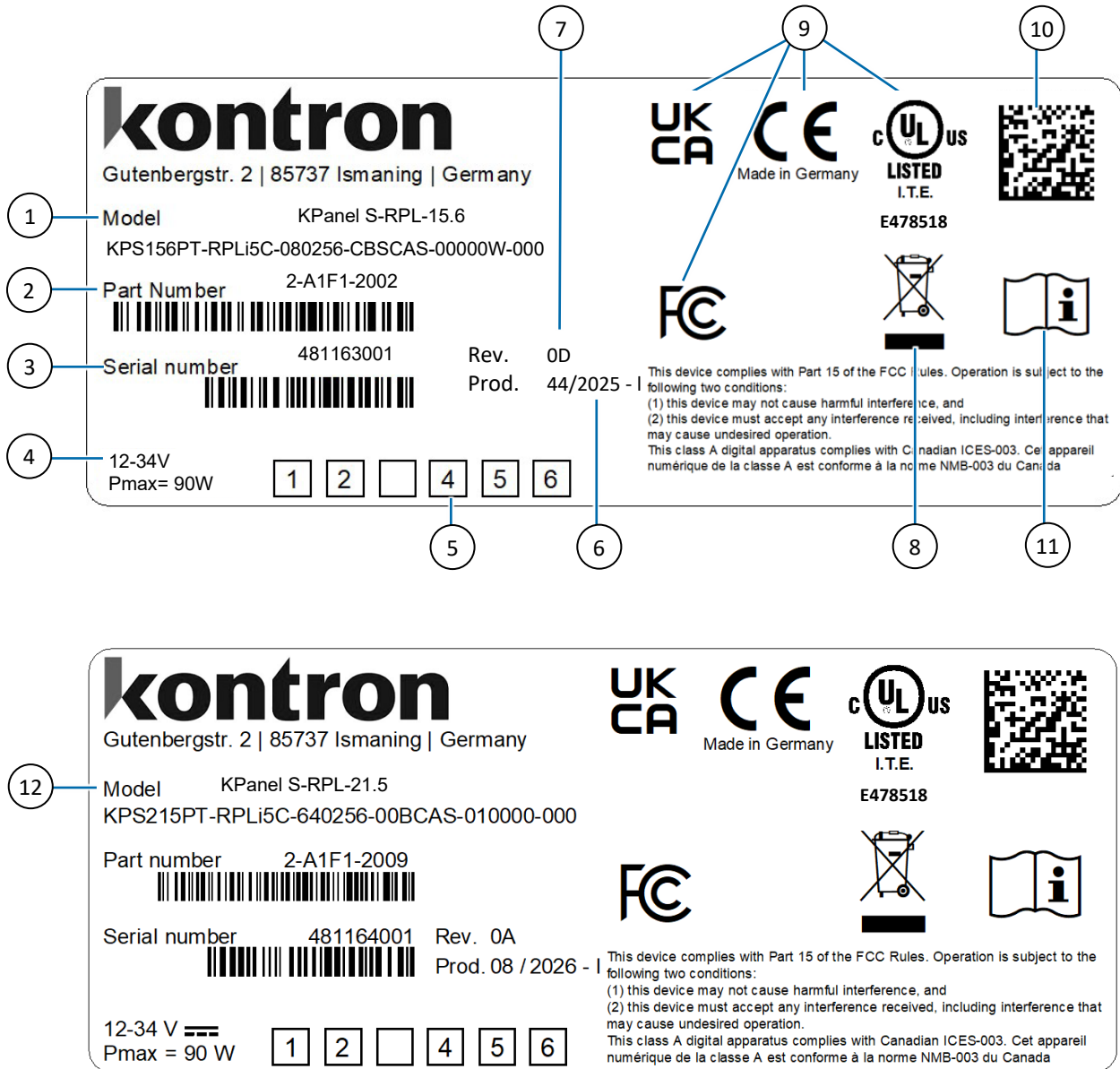

- | | |
|---|--|
| 1. Product family, with RPL processor family and display size 15.6" | 7. Revision |
| 2. Part number | 8. Disposal information |
| 3. Serial Number and bar code | 9. Compliance (CE, UK CA, UL & FCC) |
| 4. Electrical specification | 10. QR-Code |
| 5. For Internal use [1 to 6] | 11. Read and observe |
| 6. Production date | 12. Product family, with RPL processor family and display size 21.5" |

4/Product Features

Before implementing the KPanel S-RPL, Kontron recommends new users to take a few minutes to learn about the various features of the KPanel S-series of industrial HMI monitors.

4.1. Front Features

The front features an aluminum frame, with seal and a display with 2.8 mm front glass. The touch screen display supports glove operation with assembly gloves and two layers of latex gloves. To ensure that unintended touch input is disregarded the touch screen display supports glove operation, palm rejection and drop rejection.

Figure 3: Front Features

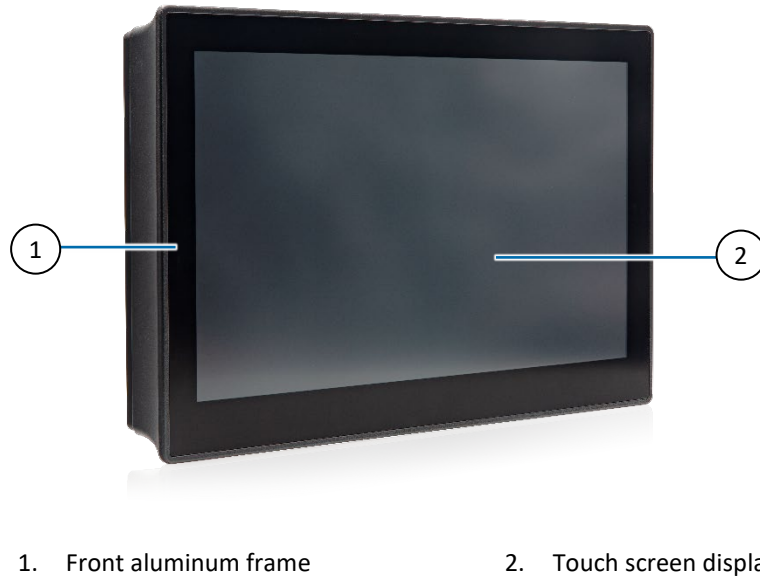

4.1.1. Touch Screen

The touch screen utilizes projected capacitive (PCAP) multi-touch technology and is positioned behind a durable tempered front glass for reliable touch performance and mechanical protection.

The glass surface of the touch area is practically wear-free and features:

- › Impact-protection
- › Scratch-resistance
- › Resistant to common liquids including petrol, alcohol and standard cleaning solutions.

The standard calibration of the touch screen includes the following functions:

- › 10 finger touch
- › Glove usage
- › Palm detection and rejection
 - › For touch surfaces larger than a normal touch finger; the touch is recognized as a palm and not reported.
- › Water detection
 - › Detecting liquids (water condition) a ghost touch will be protected by reducing sensitivity and allowing only two finger touch.
- › Immediate response time (touch controller response time < 25 ms)

When touching the touch screen with gloves, users must consider the glove type, material and thickness. Kontron recommends users to first perform an application test with gloves. The following table provides typical glove performance information.

Table 3: Glove Type Performance

Glove Type	Material	Thickness
Disposable and Hygienic gloves	Latex Nitril Vinyl/PVC	Single layer: 0.5 mm Dual layer: 0.2 mm each
Assembly gloves	Cotton	1.5 mm
Work gloves	Leather Polyester with Nitril coating	Up to 2 mm

If required special customer requirements that are available on request are:

- › Sensitivity (for the use of special working gloves)
- › Implementation of a touch detection filter
- › Attention to special liquids

4.1.2. Seal

The seal located on the front provides IP65 protection. When securing the front on the rear cover take care to ensure that the seal is clean and not damaged.

NOTICE

Seal

Take care not to damage the seal when opening and refastening the front as this may invalidate IP65 protection. Always ensure that the seal is clean with no visible damage.

4.2. Rear Cover Features

The rear cover is available in three variants. Each variant includes a designated cable entry point (Figure 4, pos. 3) that supports secure cable routing of internal cables while preserving IP protection with Kontron's installation adapters. Optional features are a power button with two USB ports and on request four antenna connectors for two Wi-Fi and two LTE antennas.

Figure 4: Rear Cover Features

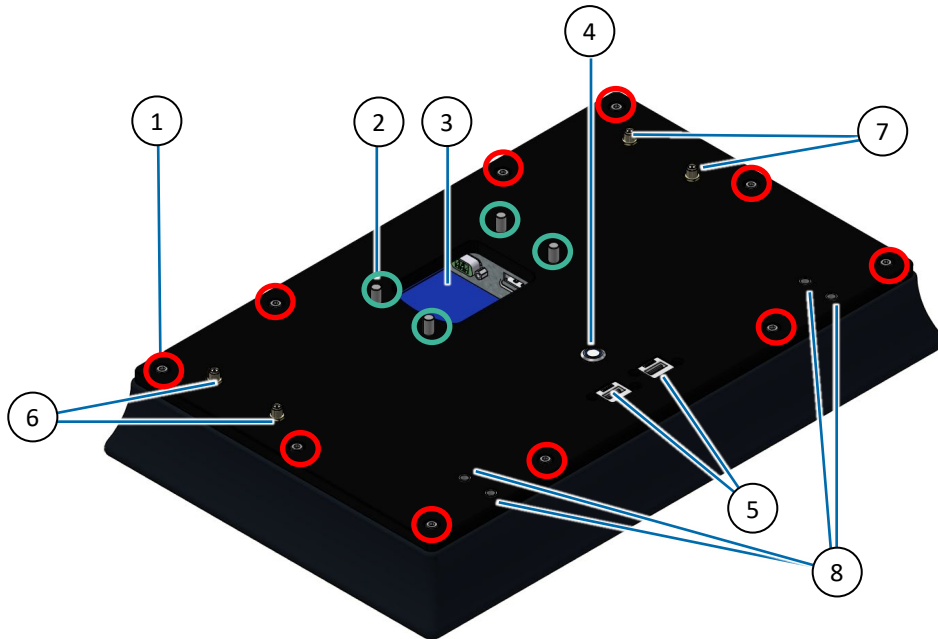

- | | | |
|---|--|----|
| 1. 10x Captive screws (shown in red) | 5. 2x USB 3.2 ports (option) | 9. |
| 2. 4 x Threaded bolts for Rittal support arm or compatible (shown in green) | 6. 2x LTE Antenna (on request) | |
| 3. 1x Cable entry point | 7. 2x Wi-Fi Antenna (on request) | |
| 4. 1x Power button (option) | 8. 4x Threaded screw openings for peripherals (handle or keyboard/mouse) | |

The rear cover is aluminum and serves as a heat sink for passive cooling. Operate only in a well-ventilated environment that does not obstruct the airflow over the rear cover and obstruct the product from dissipating heat.

When installed on a support arm or pole, loosening the rear cover's ten captive screws enables the front to hang at an angle on the two internal rear cover hinge brackets (Figure 6, pos. 6). This provides user access for the connection of internal cables.



Hot Surface

The rear cover can get very hot. To avoid burns and personal injury when handling:

- Do not touch while in operation
- Allow to cool before handling
- Wear protective gloves

NOTICE**Clearance**

Ensure proper operation by observing a minimum rear cover clearance of 20 mm (0.79 inch).

NOTICE**Ensure Sufficient Airflow**

To ensure sufficient heat dissipation, operate only in a well-ventilated environment and do not obstruct the airflow over the rear cover.

4.2.1. Cable Entry Point

The internal cables are led through the cable entry point (Figure 4, pos. 3) and routed internally to the connectors on the internal CPU module's interface panel. The user is responsible for using cables that meet the power and interface cabling requirements of the KPanel.

The four threaded bolts (Figure 4, pos. 2) around the cable entry point enable direct installation on a Rittal support arm (or compatible support arm). Installation using a VESA (100/75 mm) stand or pole is possible using Kontron's VESA adapter installed on the four threaded bolts.

4.2.2. USB Ports (option)

For easy access two USB 3.2 Gen 2 ports (Figure 4, pos. 5) are led out from the interface panel and are factory installed with IP65 protection on the rear cover. The USB ports are no longer available for connections on the interface panel.



The two USB ports implemented on the rear cover are not available on the internal interface panel.



The two USB ports are available together with the power button and on request up to four antennas.

4.2.3. Power Button (option)

For an easy start up and power down a power button (Figure 4, pos. 4) is factory installed with IP65 protection on the rear cover. The power button switches on or switches off with an orderly shutdown after the button has been pressed shortly. Pressing the power button for more than four seconds triggers a system shutdown.



The power button option is available together with two USB ports and on request up to four antennas.

4.2.4. Wi-Fi/BT® and Cellular LTE Antenna (on request)

The Wi-Fi/BT® and cellular LTE functionality is available on request only. For more information regarding Wi-Fi/BT® and Cellular LTE features, contact your local Kontron sales representative.

If Wi-Fi/BT® and/or cellular LTE are implemented, the required antennas are included in the delivery. To avoid damage, users must ensure that the correct antenna type is connected to the rear cover's antenna connectors. The Wi-Fi (RP-SMA) and Cellular LTE (SMA) connector and antenna types are not interchangeable, and incorrect connection may result in an insufficient connection or destroy the center pin.

Figure 5: Wi-Fi/BT® and Cellular LTE Connectors and Antenna Type (on request)

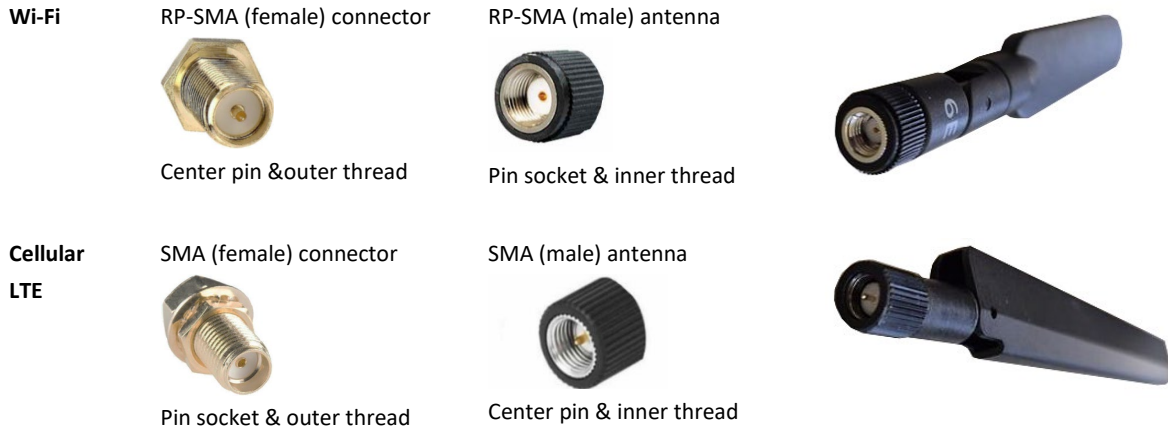

Avoid Antenna RF Exposure by:

CAUTION

- Avoid placing the antenna near people, minimum distance 20 cm.
- Avoid pointing the antenna at people.
- Keep a safe distance from the antenna especially when transmitting.

NOTICE

RP-SMA and SMA Antenna are not Interchangeable!

RP-SMA and SMA connectors and antenna are not electrically compatible. Incorrect connection may result in an insufficient connection or destroy the center pin.



Kontron recommends the use of Kontron’s reference antenna chosen to meet RF performance requirements and with a nominal impedance of 50 ohms. The reference antennas are included in the delivery. For more information, see Table 2: List of Accessories and Spare Parts.



Cellular LTE requires a Cellular network SIM card to be provided by the user. The SIM card inserts into a SIM card slot located internally on top of the CPU module.

4.3. Internal Components

The internal cables connect to the CPU module's interface panel. The user is responsible for providing and installing all internal cables. All internal cables must be secured on the internal cable relief bracket. The cables must be chosen to meet the requirements specified within this user guide and on the type label.

The internal cables include a ground cable, interface cables (Ethernet, USB, DisplayPort) and a power cable.

Figure 6: Internal Components

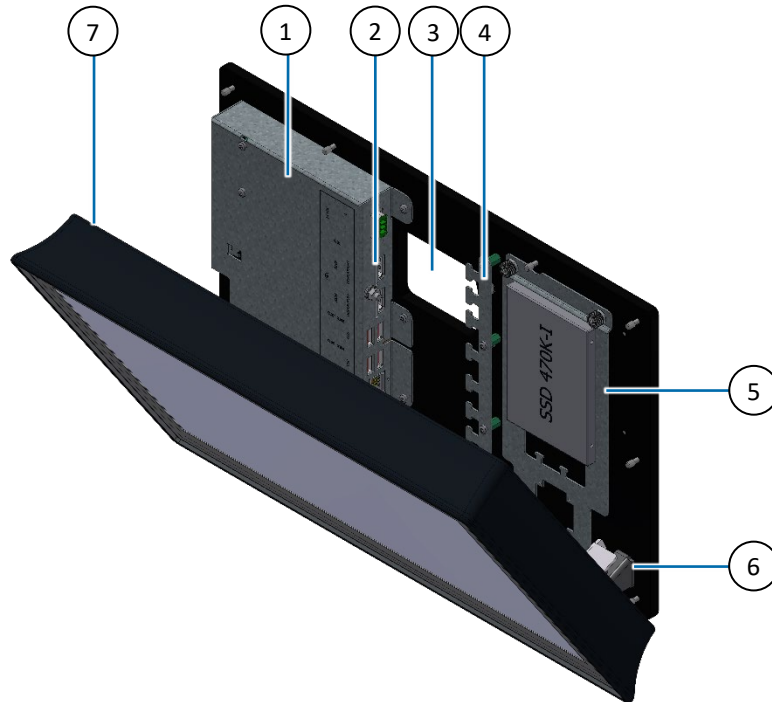

- | | |
|-------------------------|---------------------------------------|
| 1. 1x CPU module | 4. 1x Cable relief bracket |
| 2. 1x Interface panel | 5. 1x Removeable expansion plate |
| 3. 1x Cable entry point | 6. 2x Hinge brackets (left and right) |
| | 7. 1x Seal on the front |

Proper Cabling Procedure

NOTICE

When installing or disconnecting internal cables to the interface panel ensure that:

- The first cable connection and last to be disconnected is to the Ground stud.
- The last cable connection and first to be disconnected is to the Power IN connector.

Cable Reliefs

NOTICE

Connect all internal cables to the cable relief bracket with cable ties to minimize connector strain. The cable relief bracket supports second level strain relief for all connected interfaces.

4.3.1. Interface Panel

When installing or disconnecting internal cables to the interface panel ensure that the first cable connection and last to be disconnected is to the Ground stud. After the ground connection had been made connect the required interface cables (X102 to X109) to the interface panel. The last cable connection and first to be disconnected is to the Power IN connector (X101).

Figure 7: Interface Panel – KPanel S-RPL

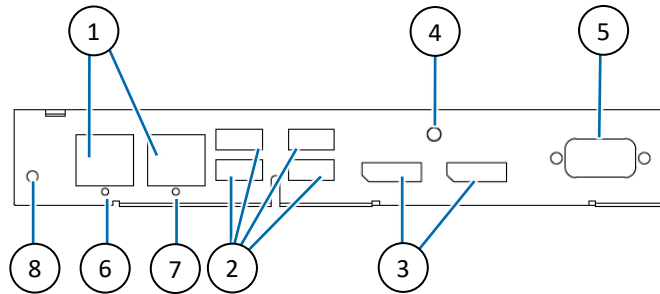

- | | |
|-------------------------------------|------------------------------|
| 1. 2x Ethernet 2.5 GbE (X102, X103) | 5. 1x Power IN 24 VDC (X101) |
| 2. 4x USB 3.2 Gen 2 (X104 to x107) | 6. 1x STAT LED (green) |
| 3. 2x DP (X108, X109) | 7. 1x PWR LED (yellow) |
| 4. 1x Ground Stud | 8. 1x Power Button |

4.3.2. Ground Stud

The ground stud connects to shield. The user is responsible for connecting the internal CPU module's ground stud to an external ground that meets the local, national and international grounding requirements, using a suitably wired cable with ground ring. The ground cable must be secured with cable ties to eliminate pull on the ground cable.

To avoid damage, observe proper grounding methods when assembling the KPanel S and ensure that the cable to the ground stud is the first cable to be connected and the last cable to be removed.

Ground Properly

⚠ CAUTION

The installation sites applied ground must meet all local, national and international regional grounding requirements.

4.3.3. Ethernet Ports (X102, X103)

The Ethernet ports (X102 and X103) each support one channel of 10/100/1000/2500 Mbit Ethernet.

For the pin assignment of the Ethernet ports, see Chapter 12.2: 2.5 GbE Ethernet Port (X102, X103).



To achieve the specified Ethernet port performance, Category 5 twisted pair cables must be used with 10/100 MByte and Category 5E, 6 or 6E with 1 GbE/2.5 GbE Ethernet networks.



Connected only to internal Ethernet networks located within the facility and not classified as TNV circuits.

4.3.4. USB 3.2 Gen 2 Ports (X104, X105, X106, X107)

The four USB ports (X104, X105, X106 and X107) support USB 3.2 Gen 2 compatible device using a USB Type A connector and are backwards compatible with USB 3.2 Gen 1 and later, and USB 2.0. To achieve the specified performance for USB 3.2 Gen 2 performance use cables that comply with the USB 3.2 standard.

For the pin assignment of the USB 3.2 Gen 2 ports, see Chapter 12.3: USB Type A 3.2 Gen 2 Port (X104- X107).



The four USB 3.2 Gen 2 ports are backwards compatible with earlier USB 3.0 and USB 2.0.

4.3.5. DisplayPorts (X108, X109)

The two DisplayPorts (DP) (X108, X109) are standard DP++ ports and support the use of passive adapters to connect to HDMI or DVI. The maximum resolution is 7680 x 4230 at 60 Hz.

For the DisplayPort pin assignment, see Chapter 12.4: DisplayPort (X108, X109).



DisplayPort ++ supports the use of passive adapters to connect to HDMI or DVI.

4.3.6. Power IN (X101)

The 3-pin Power IN connector (PSC 1.5/ 3-M) connects to an appropriate DC power supply using the mating power connector (PSC 1.5/ 3-F) included in the delivery. To wire the mating power connector, see Chapter 10.5: Wiring the Mating Power Connector. The power cable must be secured internally with cable ties to eliminate pull on the power cable. The user is responsible for connecting the Power IN connector to an external power source that meets the requirements specified in this user guide and on the type label. For the power supply specification, For more information, see Chapter 6.6: Power Specification.

The KPanel S automatically switches on when the Power IN connector is connected to a power source or after a power fail when power is recovered. For KPanel S variant including a power button the KPanel S switches on after connecting to a power source and then pressing the power button.

For the pin assignment of the Power IN connector, see Chapter 12.1: Power IN Connector (X101).

4.3.7. Power Button

The power button switches on or switches off the product. Pressing the power button for more than four seconds switches the product from the 'on' to 'off' state.

4.3.8. Power LED and State LED

The STAT LED indicates the product's power status and the PWR LED indicates the product's power-good status.

Table 4: STAT and PWR LED Description

STAT LED (green)	PWR LED (yellow)	Description
On	On	Power on (Fully operational)
Flashing	On	Sleeping
Off	On	Soft off
Off	Off	Power off

4.4. Expansion Plate

The removable expansion plate accommodates up to two expansion plate options. The bottom part of the expansion plate is permanently reserved for the automotive RTC Lithium battery option. The remaining part of the expansion plate supports the expansion plate options described in this chapter.

The removable expansion plate is only included as part of the delivery if an expansion plate option is ordered. Without an expansion plate the standard lithium battery is attached to the inner side of the rear cover.

⚠ CAUTION

Switch off Completely before Opening

To switch off completely use the power button (If provided) and remove the power cable from the external power source or disconnection device (fuse/circuit breaker) rated in accordance with the product's wire cross-section and electrical specification.



The expansion plate options are factory installed with all cables connected.

4.4.1. Automotive RTC Lithium Battery (option)

The optional automotive RTC lithium battery may be implemented if a longer lifetime is required that the standard RTC lithium battery., see Table 7: Hardware Specification.

The automotive RTC battery lifetime is > 3700 days min. at <=25°C. The automotive RTC lithium battery is located at the bottom of the expansion plate and can be accessed for replacement by removing the expansion plate.



An empty RTC lithium battery BIOS does not affect the BIOS settings. However, the system time and date are affected when the RTC lithium battery is empty and must be reconfigured after replacing the battery.



If the Automotive battery option is implemented, the dual Serial Port, CF memory card, 2.5" SDD drive or 2.5" SDD Dual M.2 RAID module options are available.

4.4.2. Dual Serial Port (RS232) (option)

The optional serial port expansion option is factory installed and supports two RS232 serial ports.



If the dual Serial Port option is implemented the 2.5" SDD drive, 2.5" SDD Dual M.2 RAID module and CF memory card options are not available.

4.4.3. CF Memory Card (option)

The optional CF memory card slot enables reading and writing to a CF Type I/II memory card, with support for memory features such as S.M.A.R.T, TRIM and DevSleep.



If the CF memory card slot option is implemented the 2.5" SDD drive, 2.5" SDD Dual M.2 RAID module and dual Serial Port options are not available.

4.4.4. 2.5" SSD Drive (option)

The optional 2.5" SSD drive (SATA III 6 Gb/s) supports densities of 256 GByte, 512 GByte or 1 TByte.



If the 2.5" SDD is implemented the 2.5" SDD Dual M.2 RAID module, CF memory card and dual Serial Port options are not available.

4.4.5. 2.5" SSD Dual M.2 RAID Module (option)

The optional 2.5" SSD (SATA III 6 Gb/s) dual M.2 RAID module with two M.2 2280 Key M SSDs (256 GByte, 512 GByte, 1 TByte) and supports RAID 1/RAID 0.



If 2.5" SSD Dual M.2 RAID module option is implemented the 2.5" SDD, CF memory card and dual Serial Port options are not available.

4.4.6. Expansion Plate Options (on request)

Further expansion plate options are available on request only. These options include:

- › Serial Port RS232 and Audio
- › Serial Port RS232 and Speaker
- › Dual CAN

For more information regarding these options, contact your local Kontron sales representative.



If an on request expansion plate option is implemented the 2.5" SSD dual M.2 RAID, 2.5" SDD, CF memory card and dual Serial Port options are not available.

4.5. Peripheral Devices

The featured external peripheral devices are the keyboard-holder, with or without a mouse holder, and a handle.



The keyboard holder and the handle both utilize the same mounting openings, allowing only one to be installed at a time.



Prerequisite for the mouse holder is the installation of the Keyboard holder. The mouse holder may be installed on to the left or the right sides of the keyboard holder

Figure 8: Peripheral Devices (keyboard, mouse and handle)

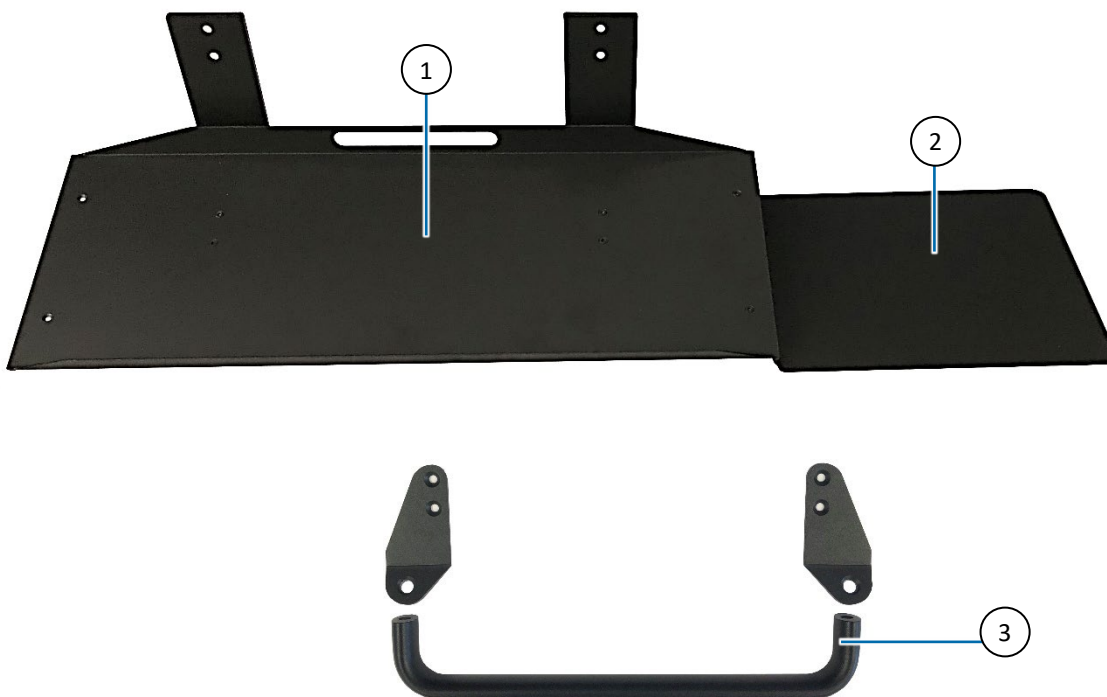

1. Keyboard holder
2. Mouse holder
3. Handle with brackets

5/Order Information

Table 5: Order Number Information

Product Name	Description
2-A1F1-yxxx	2-A1F: KPanel S product family
2-A1F1-yxxx 2-A1F2-yxxx	1: KPanel S-RPL 2: KPanel S-AML/ADN
2-A1F1- 2 xxx 2-A1F1- 0 xxx	2: Standard 0: Customer specific product (MOST)
2-A1F1-2 xxx	xxx: Configuration number

6/Product Specification

6.1. Block Diagram

Figure 9: Block Diagram KPanel S-RPL

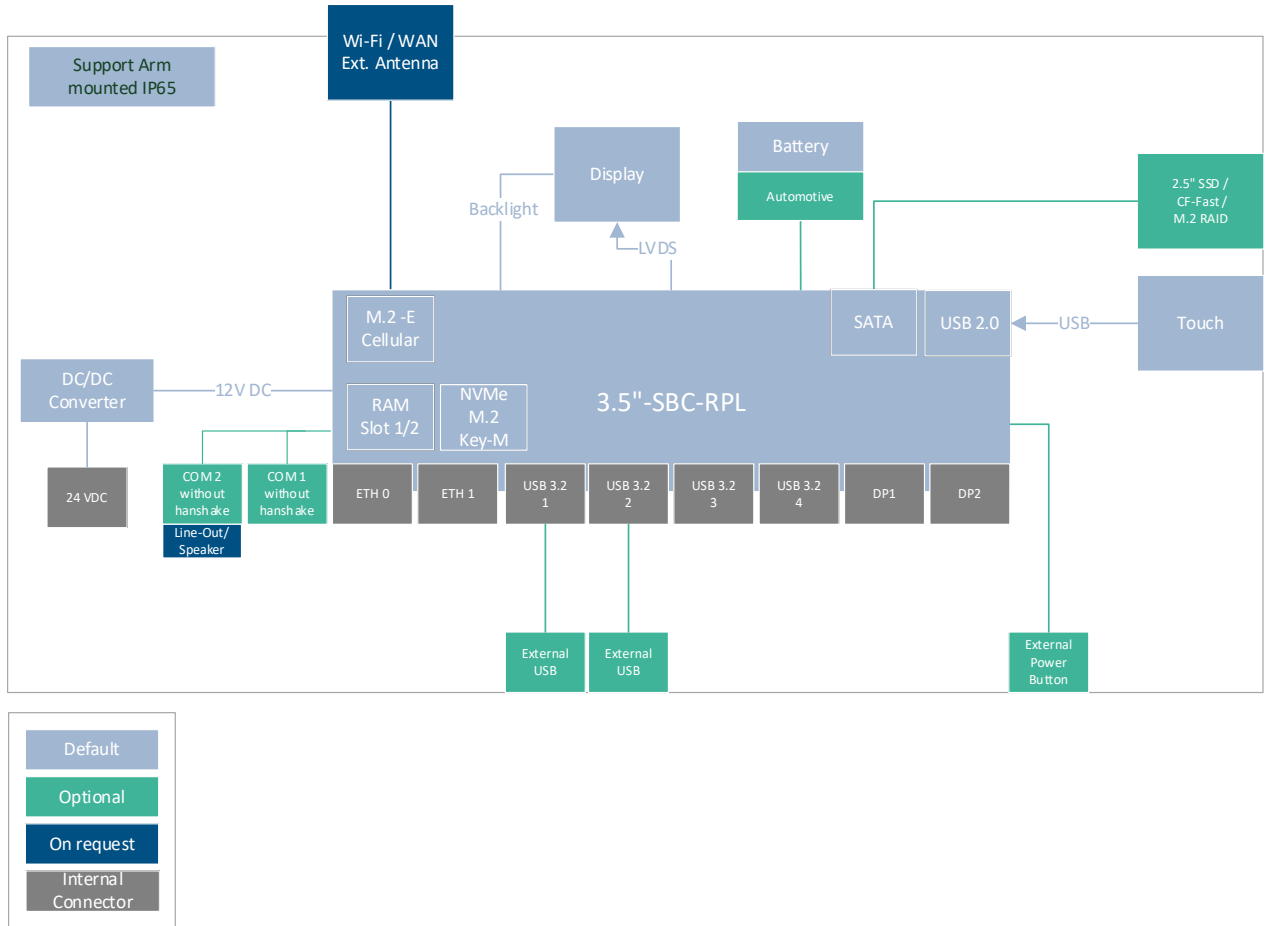

6.2. Display Specification

Table 6: Display Specification

Display Size	15.6" (G156HCE-E01)	21.5" (G215HCJ-L01)
Resolution (pixel)	1920x1080	1920x1080
Screen Size	15.6 Inch	21.5 Inch
Contrast Ratio	1000:1 typ.	1000:1 typ.
Brightness	450 cd/m2	400 cd/m2
Angle View (H/V)	178°/178° typ.	178°/178° typ.
Colors	16.7 million	16.7 million
LED Lifetime (> 50%, 25°C)	> 50.000 hr	> 50.000 hr
Protection Glass	✓	✓
PCT (touch screens)	✓	✓

6.3. Hardware Specification

Table 7: Hardware Specification

KPanel S-RPL	Description			
SBC	3.5" SBC RPL			
CPU	Intel® Core™ i7-1365UE	Intel® Core™ i5-1345UE	Intel® Core™ i3-1315UE	Intel® U300
System Memory	SODIMM DDR5 Up to 64 GByte max. (options: 8 GByte, 16 GByte, 32 GByte, 64 GByte) 2x SODIMM per Channel			
Storage	M.2 2280 NVMe Up to 1 TByte max. (options: 128 GByte, 256 GByte, 512 GByte and 1 TByte)			
Interface Panel	2x 2.5 GbE 4x USB 3.2 Gen 2 2x DP++			
RTC	System clock standard RTC lithium battery 1000 days min. backup time at <=25°C			
Options	<p>Expansion plate options:</p> <ul style="list-style-type: none"> ➤ Automotive Battery (lifetime > 3700 days min. at <=25°C) ➤ 2.5" SSD drive SATA III up to 1 TByte max. <ul style="list-style-type: none"> ➤ Options: 256 GByte, 512 Gbyte and 1 TByte ➤ 2.5" SSD dual M.2 RAID module with 2x M.2 2280 SSDs SATA III up to 1 TByte <ul style="list-style-type: none"> ➤ Options: 256 GByte, 512 Gbyte and 1 TByte ➤ CFast slot for Type I/II memory card ➤ Dual Serial Ports RS232 <p>Peripheral options:</p> <ul style="list-style-type: none"> ➤ Keyboard-holder ➤ Keyboard and mouse holder ➤ Handle ➤ VESA adapter ➤ Portrait adapter for support arm <p>For more information, contact your local Kontron sales representative.</p>			
On Request	<p>The following are available on request only:</p> <ul style="list-style-type: none"> ➤ Wi-Fi 6E M.2 Key E 2230 module ➤ Cellular LTE M.2 Key B 3042 module ➤ Serial Port RS232 and Audio (on the expansion plate) ➤ Serial Port RS232 and Speaker (on the expansion plate) ➤ Dual CAN (on the expansion plate) <p>For more information, contact your local Kontron sales representative.</p>			

6.4. Software Specification

Table 8: Software Specification

KPanel S-RPL	Description
BIOS	AMI uEFI BIOS
Operating System	Windows 10/11 IoT, Linux Debian or QIWI



The product comes with pre-installed Operating System (OS) and all necessary drivers. For BIOS updates and Board Support Packages (BSP), visit Kontron's [Customer Section](#).



The QIWI toolkit enables the fast and fluent configuration of web-based visualization without requiring programming and OS knowledge. Just set up the pre-installed QIWI toolkit browser.



QIWI toolkit can be set up on multiple monitors (not limited).

6.5. Environmental Specification

Table 9: Environmental Specification

KPanel S- RPL		Description
Temperature	operating	0°C to 50°C (32°F to 122°F)
	non-operating	-20°C to 70°C (-4°F to 158°F)
Relative Humidity		10% to 90% @ 39°C, non-condensing
Altitude		Up to 5000 m (9900 ft. approx.)
Shock (according to EN 60068-2-27)	operating	15 G, 11 ms (half sine), shock count 3/direction
	non-operating	30 G, 11 ms (half sine) shock count 3/direction
Vibration (according to: EN 60068-2-6)	operating	10-500 Hz: 1 G
	non-operating	10-500 Hz: 2 G
MTBF		67630.39 hours @ 40°C, GB KPanel S-RPL, Intel® i5 Processor, 8 GByte DDR5 SODIMM and 256 GByte M.2 NVMe 2280 SSD.

Indoor Use Only

The product is intended for indoor use only. To avoid product damage do not use the product in a sheltered outdoor, outdoor or sunlit environment.

Observe that the product is not exposed to direct sunlight (UV radiation):

NOTICE

- Prolonged exposure shortens field life and invalidates the warranty
- Short exposure may lead to higher temperatures inside the product and cause permanent damage
- Direct exposure accelerates long-term aging

For intend use in an outdoor environment or a sunlit environment, contact your Kontron representative.

6.6. Power Specification

Before connecting the KPanel S to an external 24 VDC power supply, ensure that the external 24 VDC power supply meets the electrical specification as specified in this user guide and documented on the type label, and that protection and supply limitation have been taken into consideration.

The external 24 VDC power supply must automatically recover from AC power loss and start up under peak loading. Connect the KPanel S only to an external 24 VDC power supply designed to achieve NEC Class-2 and Limited Power Source (LPS) and used according to the manufacturer's instructions.

External Power Source

⚠ CAUTION

Only connect the product to an external power source providing the voltage type (AC or DC) and the input power (max. current) specified on the Kontron Type Label.

The external power source must meet the requirements of ES1/PS2 according to IEC/UL 62368-1.

Disconnection Device and Power Protection

⚠ CAUTION

Observe that wiring and short-circuit/overcurrent protection is performed according to the applicable standards, regulations and in respect to the product's electrical specification. The disconnecting device (fuse/circuit breaker) rating must be in accordance with the product's wire cross-section.

Avoid Forced Shutdown

NOTICE

Do not disconnect the power while the product is operating!

Performing a forced shut down can lead to loss of data or other undesirable effects!

Minimum Immunity

NOTICE

Ensure the external DC power supply has been fully tested to meet the minimum immunity of AC inputs requirements, as stipulated in IEC 55024. Including power supplies marketed with a separate AC/DC power converter.

Power Cables

NOTICE

To protect the product and any connected peripherals, make sure that the power cables have the right diameter to withstand the maximum available current.

Table 10: Electrical Specification

KPanel S-RPL	Description
Input Voltage (range)	12 VDC to 34 VDC (max. 36 VDC)
Power max (Pmax)	90 W

6.6.1. Power Supply Protection Requirements

The external DC power supply must incorporate protection and supply features such as over current, over temperature, over voltage and brownout protection, to protect the product against fluctuations and interruptions and ensure operation without loss of data or product damage.

Brownout

If there is an unintentional voltage drop in the mains power supply for longer than the specified holdup time (brownout), all supply voltages should be shut down and remain in the off state long enough to allow internal voltages to discharge sufficiently. During the off-state time do not disconnect or add cables to/from the I/O connectors. Failure to observe the off-state time means that parts of the product or attached peripherals may work incorrectly or suffer a reduction of MTBF.

NOTICE

The minimum off state time, to allow internal voltages to discharge, depends on the power supply used and additional electrical factors. To determine the required off state time, each case must be considered individually. For more information, contact [Kontron Support](#).

6.6.2. Functional Earth Ground Stud

The ground stud connects to shield. The user is responsible for connecting the internal CPU module's ground stud to an external ground that meets the local, national and international grounding requirements, using a suitably wired cable with ground ring. The ground cable must be secured with cable ties to eliminate pull on the ground cable.

Ground Properly

CAUTION

The installation sites applied ground must meet all local, national and international regional grounding requirements.

Include a Functional Earth

CAUTION

No isolation between Power IN, GND and the KPanel S display housing. Users must include a functional earth.

To avoid damage to the product, observe proper grounding methods:

1. Connect the product to ground before switching on the product.
2. When assembling, connect the first cable to the functional earth ground stud and when disassembling, the last cable to be removed is the ground cable.

6.7. Compliance

The KPanel S-RPL plans to comply with the relevant requirements and the approximation of the laws relating to 'CE' and the standards that are constitutional parts of the declarations and later thereof.

Table 11: Compliance

KPanel S-RPL	Description
Compliance	CE, UK CA, UL, FCC



For the product Declaration of Conformity (DOC), visit Kontron's [Customer Section](#).



If the product is modified, the prerequisites for specific approvals may no longer apply!



Kontron is not responsible for any radio television interference caused by unauthorized modifications of the delivered product or the substitution or attachment of connecting cables and equipment other than those specified by Kontron. The correction of interference caused by unauthorized modification, substitution or attachment is the user's responsibility.

7/Thermal and Power Management

7.1. Passive Cooling

The KPanel S-RPL is designed with a flat aluminum rear cover that serves as a heatsink and dissipates heat into the environment for passive cooling. The rear cover surface can get very hot and precautions must be taken before handling or touching.

Do not obstruct the airflow around the rear cover as this may cause a build-up of heat. Observe a minimum clearance around the product.



Hot Surface

The rear cover can get very hot. To avoid burns and personal injury when handling:

- Do not touch while in operation
- Allow to cool before handling
- Wear protective gloves

NOTICE

Ensure Sufficient Airflow

To ensure sufficient heat dissipation, operate only in a well-ventilated environment and do not obstruct the airflow over the rear cover.

NOTICE

Clearance

Ensure proper operation by observing a minimum rear cover clearance of 20 mm (0.79 inch).

7.2. Mount Orientation

The KPanel S is designed for vertical operation ($\pm 25^\circ$) on a Support arm or VESA stand/pole in landscape and portrait. When mounting the KPanel S ensure the mount orientation does not obstruct the airflow over the rear cover, as this may hinder the heat dissipation.

For more Information on how to install the KPanel S on a support are or VESA Stand or pole using the adapters required, see Chapter 9/: Installation.

Figure 10 Vertical Mount Orientation (permitted)

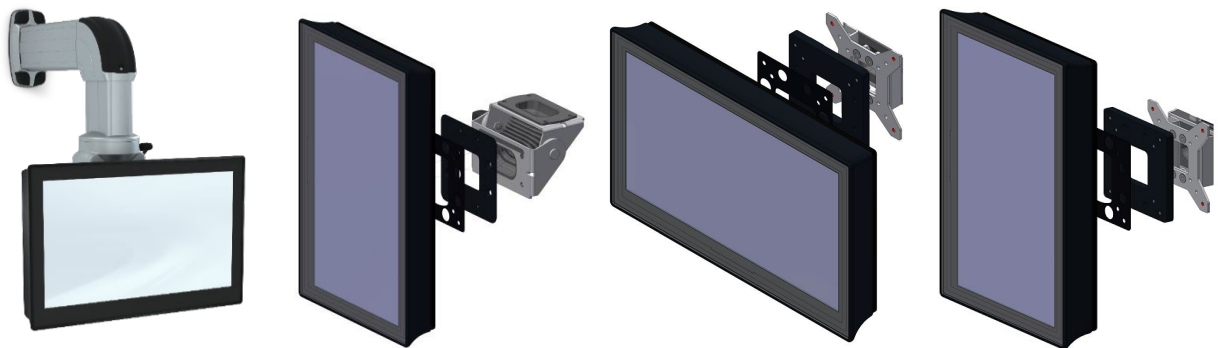

NOTICE

Mount Vertically

Mounted in the vertical position (portrait or landscape) $\pm 25^\circ$.

7.3. Minimum Clearance

To provide maximum airflow away from the rear cover, observe a minimum clearance distance (keep out area) of 20 mm (0.79 inch) to the surrounding environment.

NOTICE

Clearance

Ensure proper operation by observing a minimum rear cover clearance of 20 mm (0.79 inch).

7.4. Maximum Processor Power and Temperature

The Intel® Core-I Raptor-Lake (RPL) family of processors provides internal thermal monitoring with a temperature sensor. To allow for optimal operation and long-term reliability, the processor must operate in the specified temperature range. To avoid overheating the processor performs automatic thermal management, to keep the processor temperature below the highest value of the temperature range.

Table 12: Processor TDP and Maximum Temperature Values

Processor		Power	Temperature	
Intel® Core U-Series	(Core, Cache, Frequency)	TDP ^[1]	DTR	T-Junction
Intel® U300E	5 Cores, 8 MB Cache, up to 4.3 GHz	28 W	+/-70°C (158°F)	100°C (212°F)
Intel® Core™ i3-1315UE	6 Cores, 10 MB Cache, up to 4.5 GHz	28 W	+/-70°C (158°F)	100°C (212°F)
Intel® Core™ i5- 1345UE	10 Core, 12 MB Cache, up to 4.6 GHz	28 W	+/-70°C (158°F)	100°C (212°F)
Intel® Core™ i7- 1365UE	10 Core, 12 MB Cache, up to 4.9 GHz	28 W	+/-70°C (158°F)	100°C (212°F)

^[1] TDP High power



Dynamic Temperature Range (DTR) defines the maximum temperature range during operation starting from boot time temperature and within the T-Junction limits. For further DTR information for your processor or a higher DTR-value, contact [Kontron Support](#).



T-Junction is the maximum junction temperature allowed at the processor die.

7.5. Power Consumption and Thermal Monitoring

The implemented Intel® processor series provides settings for maximal power consumption to help limit the thermal load. Changing these settings influences the performance of the application. The maximum ambient temperature around the KPanel S depends mainly on the power consumption of the processor, chipset, and installed M.2 modules and connected USB devices.



The maximum system ambient temperature depends mostly on the power consumption of the processor, chipset and third-party components such as M.2 modules and USB devices.



For the KPanel S-RPL electrical specification, see Chapter 6.6: Power Specification.

7.6. Derating TDP Curve

The derating TDP curve shows how the maximum allowable performance (such as current, power, or load) of a device decreases as the ambient temperature increases. At lower temperatures, the KPanel S can operate at full capacity and as the ambient temperature rises, the KPanel S must operate at reduced capacity to avoid overheating. The derating TDP curve acts as a guideline to help users set TDP power limits to maintain safe operating conditions for the various KPanel S load configurations.

The operating range of the KPanel S-RPL is 0°C to 50°C (32°F to 122°F). However, when operated at temperatures above 35°C (95°F) to protect the processor, the performance of the processor reduces. For full performance over the operating temperature range users must observe that airflow over the rear cover is not obstructed to enable sufficient heat to be dissipated into the environment.

The following derating curve is for the high level TDP of 28 W.

Figure 11: TDPs vs Temperature

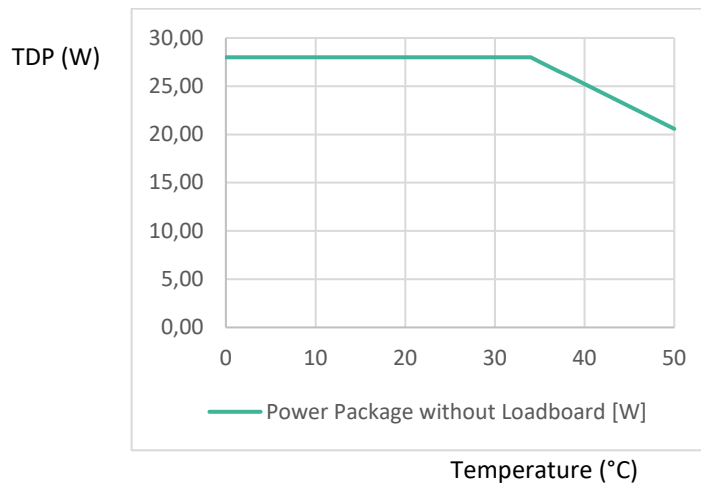

The specified operating temperature range is 0°C to 50°C (32°F to 122°F). However, when operated at temperatures above 35°C (95°F) to protect the processor, the performance of the processor reduces. For full performance over the operating temperature range users must observe that airflow over the rear cover is not obstructed to enable sufficient heat to be dissipated into the environment.

7.7. Configuring the Processor TDP

The TDP configuration is performed in the BIOS Advanced setup menu, using the Configurable TDP Boot Mode. The BIOS default setting is [nominal] and possible BIOS settings are [Nominal, Low Level, High Level].

7.8. Third Party Components

The KPanel S is factory configured as ordered and requires no further hardware configuration with third party components by the user.

NOTICE

Protection Label

Opening the product may damage internal components and invalidate the warranty.



If the product is modified with a third party product, the prerequisites for specific approvals may no longer apply!

8/Mechanical Specification

The KPanel S-RPL is available with display sizes 15.6" and 21.5". This chapter provides an overview of the mechanical dimension for each display size.

Table 13: Mechanical Specification

KPanel S-RPL		Description
15.6" Display	Width, Height, Depth	392.57 x 252.07 x 55 mm (15.456 x 9.924 x 2.165 inch)
	Weight	4.7 Kg (10.36 lb)
21.5" Display	Width, Height, Depth	525.67 x 328.67 x 60 mm (20.696 x 12.940 x 2.362 inch)
	Weight	7.6 Kg (16.76 lb)
Front		Protected tempered front glass
Outer Case		Aluminum
Mounting		Rittal support arm (or compatible support arm) VESA (100/75 mm) stand or pole, with Kontron VESA Adapter
Protection Class		IP65 Front IP65 Rittal support arm or IP65 VESA stand or pole IK06 Shock rating (strike with a 500 g hammer from a distance of 20 cm)
Cooling		Passive cooling

For mechanical drawings and 3D files and panel cutout dimensions for each display size, visit Kontron's [Customer Section](#).



For KPanel S-RPL mechanical information including mechanical drawings and 3D files, visit Kontron's [Customer Section](#).

8.1. 15.6" Mechanical Dimension

Figure 12: 15.6" Dimension Diagram (mm/inch)

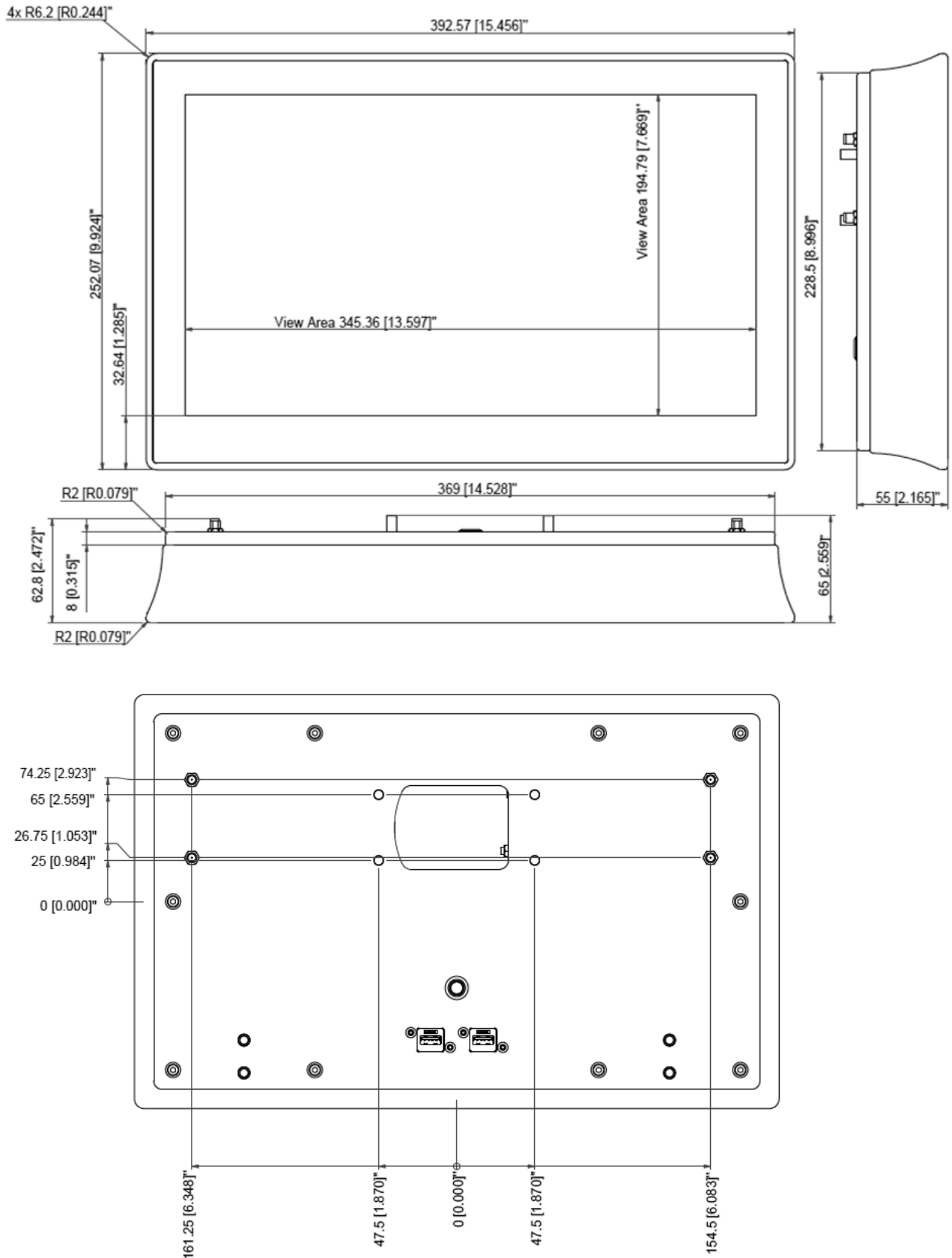

9/Installation

The KPanel S-RPL is designed for direct installation on a Rittal support arm (or compatible support arm), or on a VESA (100/75 mm) stand or pole using an additional VESA Adapter.

9.1. Before Installing

Before installing the KPanel S on a Rittal support arm (or compatible support arm) or VESA (100/75 mm) stand or pole, read and observe the instructions in this user guide and observe the safety instructions in Chapter 2/: General Safety Instructions.

Ensure the load capacity of the Rittal support arm (or compatible support arm) or VESA stand or pole is high enough to support the weight of the product.

CAUTION

Do Not Install Alone

Due to the product's weight, installing the product alone may result in damage to the product or personal injury.

NOTICE

Load Capacity

The Rittal support arm (or compatible support arm) or the VESA stand or pole's load capacity must be high enough to support the weight of the product.

NOTICE

Clearance

Ensure proper operation by observing a minimum rear cover clearance of 20 mm (0.79 inch).

NOTICE

Ensure Sufficient Airflow

To ensure sufficient heat dissipation, operate only in a well-ventilated environment and do not obstruct the airflow over the rear cover. Make sure other devices do not heat up the product.

NOTICE

Mount Vertically

Mounted in the vertical position $\pm 25^\circ$.

NOTICE

Indoor Use Only

The product is intended for indoor use only. To avoid product damage do not use the product in a sheltered outdoor, outdoor or sunlit environment.

Observe that the product is not exposed to direct sunlight (UV radiation):

- › Prolonged exposure shortens field life and invalidates the warranty
- › Short exposure may lead to higher temperatures inside the product and cause permanent damage
- › Direct exposure accelerates long-term aging

For intend use in an outdoor environment or a sunlit environment, contact your Kontron representative.

Mounting Screws**NOTICE**

Mount using the screws provided in the VESA Adapter kit and Portrait Adapter kit, selected with the correct length and size to securely mount the product without damage.

9.2. Installation Support Arm

Install directly on a Rittal support arm (or compatible support arm). The support arm is not included in the delivery and must be provided by the user. Install the product on the support arm as specified by the support arm's manufacturer and always use all four threaded bolts on the rear cover to secure the KPanel S.

To change the orientation of the KPanel S on the support arm from landscape (default) to portrait, users are required to install the portrait adapter between the rear cover and the support arm. The portrait adapter kit is available as a spare part.

Cable Protection**NOTICE**

Use cable protection elements to protect the cables within the arm from sharp profiles or to prevent cables from kinking in rotating arm components.

Attach Support Arm**NOTICE**

Always secure using all four screws when attaching a support arm to the rear cover.



For the Portrait Adapter Kit, see Table 2: List of Accessories and Spare Parts.

Figure 14: Support Arm Installation (landscape and portrait)

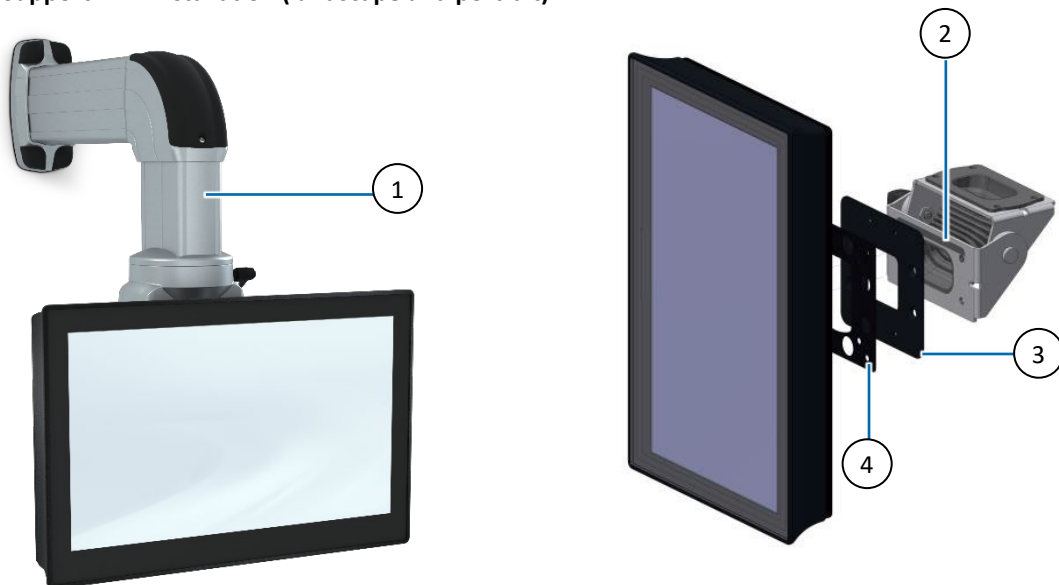

- | | |
|---------------------------------|----------------------------|
| 1. Support arm | 3. Portrait adapter |
| 2. Support arm mounting fixture | 4. Portrait adapter gasket |

To install the KPanel S on a Rittal support arm (or compatible) in landscape, perform the following

1. Following the support arm manufacturer's instructions and place the support arm's foot over the four threaded M6 bolts on the rear cover.
2. Fasten the support arm's foot to the rear cover using four M6 nuts. Do not exceed the maximum allowed torque for the nuts.

The portrait adapter changes the display orientation by 90° (landscape to portrait) for a Rittal support arm (or compatible support arm).

Figure 15: Portrait Adapter and Gasket

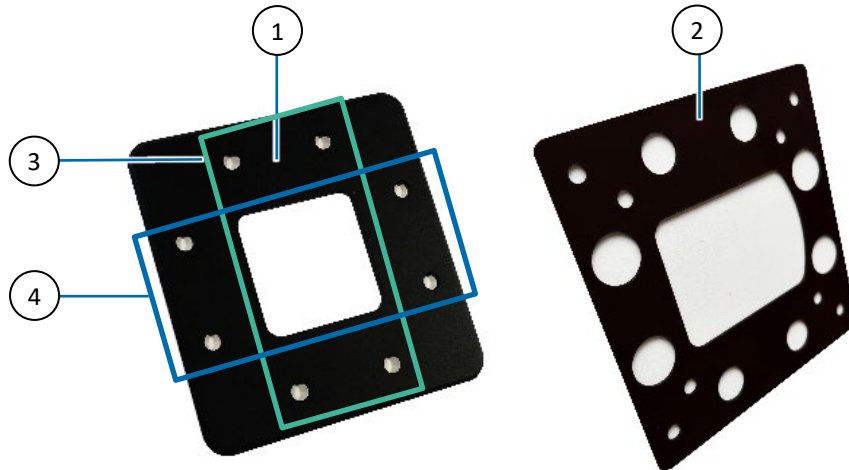

- | | |
|--|---|
| <ol style="list-style-type: none"> 1. Portrait adapter 2. Gasket | <ol style="list-style-type: none"> 3. 4x M6 nuts openings for the rear cover threaded bolts (green) 4. 4x M5x8 Tx screws openings for the support arm foot (blue) |
|--|---|

To install the KPanel S on a Rittal support arm (or compatible) in portrait, perform the following:

1. Place the gasket and then portrait adapter over the four threaded bolts on the rear cover.
2. Fasten the portrait adapter to the rear cover using the four M6 nuts provided in the Portrait Adapter Kit, do not exceed the maximum allowed torque for the nuts.
3. Secure the KPanel-S with portrait adapter to the support arm's foot using the four M5x8 Tx screws provided in the Portrait Adapter Kit.

9.3. Installing VESA (100/75 mm) Stand or Pole

To install the product on a user supplied VESA compatible (100/75 mm) stand or pole, use the VESA adapter kit. The VESA mounting interface has a square pattern and as such enables the KPanel S to be installed as landscape or portrait. The VESA adapter kit is available as an accessory.

Cable Protection

NOTICE

Use cable protection to protect cables within the pole from sharp profiles or to prevent cables from kinking.

Attach to VESA Stand or Pole

NOTICE

The four screws must meet the requirements of the VESA stand or pole's manufacturer. The four screws must not exceed the specified maximum penetration length 9 mm (0.35"). Always install using all four screws and do not exceed the screw's maximum torque.



For the VESA Adapter Kit, see Table 2: List of Accessories and Spare Parts.

Figure 16: VESA Arm Installation (landscape and portrait)

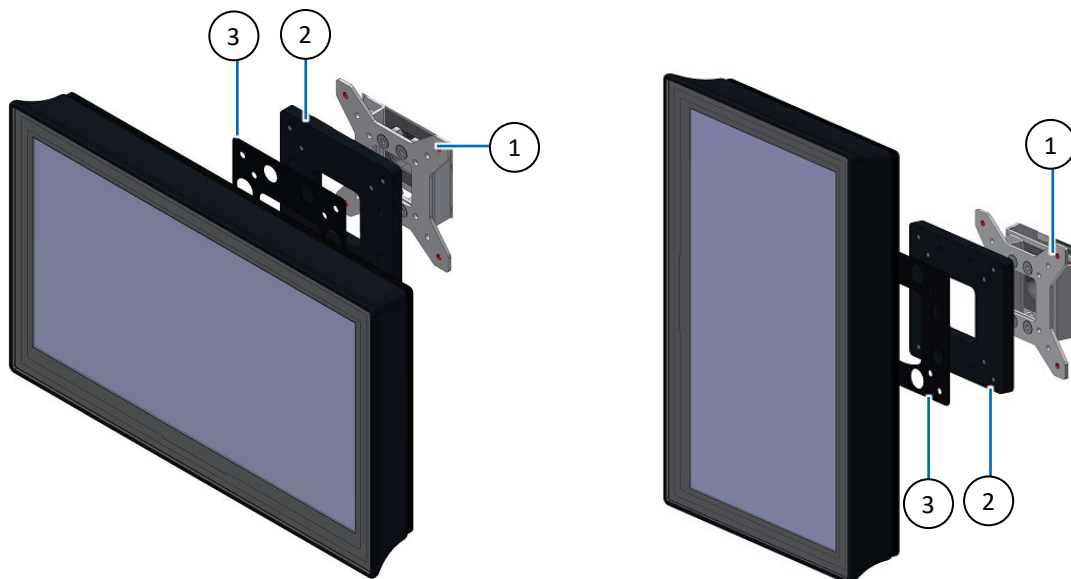

- | | |
|-------------------------------|-----------|
| 1. VESA stand or pole fixture | 3. Gasket |
| 2. VESA adapter | |

Figure 17: VESA Adapter and Gasket

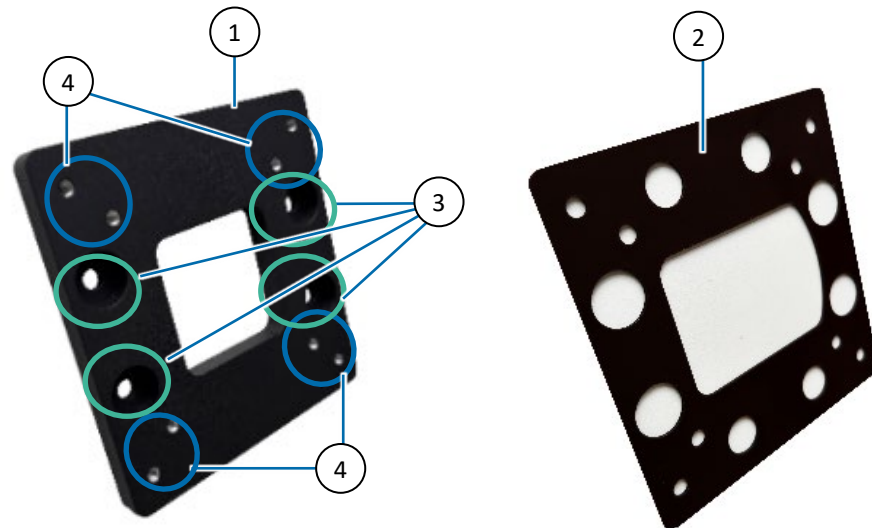

- | | |
|--|--|
| <ol style="list-style-type: none"> 1. VESA adapter (100/75 mm) 2. Gasket | <ol style="list-style-type: none"> 3. 4x M6 nut openings for rear cover threaded bolts (shown green) 4. 4x M5x8 Tx screw threaded openings for VESA (100/75 mm) (shown blue) |
|--|--|

To install the KPanel-S on a VESA stand or pole, perform the following

1. Place the gasket and then VESA adapter over the four threaded bolts on the rear cover.
2. Fasten the VESA adapter to the rear cover using four M6 nuts provided in the VESA Adapter kit, do not exceed the maximum allowed torque for the nuts.
3. Secured the KPanel S with VESA adapter to a VESA compatible stand or pole using the four M5x8 Tx screws provided in the VESA Adapter kit.

10/ Assembly

The KPanel S-RPL is factory installed with the ordered hardware configuration to enable direct assembly in the field on a Rittal support arm (or compatible support arm) or VESA (100/75 mm) stand or pole. Users are responsible for the assembly of the internal cables.

10.1. Before Assembling

Before assembling the internal cables, read the instructions in this user guide and observe the safety instructions in Chapter 2/ General Safety Instructions.

Handling and Operation

⚠ CAUTION

Handling and operation of the product is permitted only for skilled personnel aware of the associated dangers within an access-controlled workplace that fulfills all necessary technical and environmental requirements.



ESD Sensitive Device!

Follow the safety instructions for components that are sensitive to electrostatic discharge (ESD). Failure to observe this warning notice may result in damage to the product or/and internal components.

Closed Product

⚠ CAUTION

The product is only properly closed when the rear cover is fastened to the front using all ten captured screws.

Ground Properly

⚠ CAUTION

The installation sites applied ground must meet all local, national and international regional grounding requirements, using a suitable cable with ground ring. Always connect the ground cable first and the power cable last.

External Power Source

⚠ CAUTION

Only connect the product to an external power source providing the voltage type (AC or DC) and the input power (max. current) specified on the Kontron Type Label.

The external power source must meet the requirements of ES1/PS2 according to IEC/UL 62368-1.

Power Disconnection Device or Circuit Breaker

⚠ CAUTION

Before connecting any cables ensure that the external power cable is disconnected from the external power source physically or using a disconnection device (fuse or circuit breaker) rated in accordance with the product's wire cross-section and meeting the product's electrical specification!

Cable Reliefs

NOTICE

Connect all cables to the cable relief bracket with cable ties to minimize connector strain. The cable relief bracket supports second level strain relief for all connected interfaces.

NOTICE**Damage**

Handle with care to avoid damage to the front display screen.

10.2. Opening and Closing for Initial Assembly

To open the KPanel S for internal assembly, follow the instructions within this chapter. When open, the product's hinge brackets have a wide angle to support easy access to internal components.

Figure 18: Opening and Closing the KPanel S-RPL

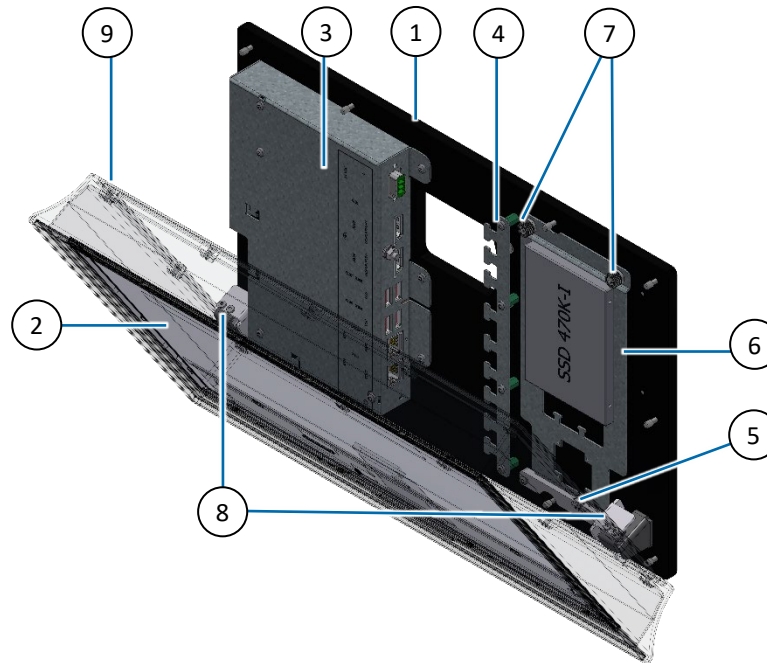

- | | |
|-----------------------------------|---------------------------------------|
| 1. Rear cover | 6. Expansion plate (removable) |
| 2. Front (shown here transparent) | 7. 2x Expansion plate knurled screws |
| 3. CPU module | 8. 2x Hinge brackets (left and right) |
| 4. Cable relief bracket | 9. Seal |
| 5. Retaining bracket | |

NOTICE**Captive Screws**

To ensure IP65 compliance, always fasten the front to the rear cover using all ten captive screws and the required torque of 1.3 NM.

NOTICE**Seal**

Take care not to damage the seal when opening and securing the front as this may invalidate IP65 protection. Always ensure that the seal is clean with no visible damage.



The product's hinge brackets include a cover to stop cable or other items from entering the hinge.

To open and close the KPanel S for internal assembly, perform the following:

1. Install the KPanel S on the user supplied Rittal support arm (or compatible support arm) or VESA (100/75 mm) stand or pole, see Chapter 9/: Installation.
2. Open by loosening the ten captive (M4) screws on the rear cover using an Allen key (size: 3) and carefully moving the front away from the rear cover, while taking care not to damage the front's seal, until the front hangs at an angle on the two hinge brackets.
3. Close by ensuring the seal on the front is clean and not damaged before moving the front carefully on to the rear cover. Fasten the ten captive (M4) screws by hand and then fasten the ten captive screws crosswise using an Allen key (size 3) while applying a torque of 1.3 NM.

10.3. Assembling the CPU Module Cables

The user is responsible for connecting the power, ground and interface cables to the CPU module and must ensure the internal ground stud connects to an external ground that meets the local, national and international grounding using a suitable cable with ground ring.

To connect the cables to the internal CPU module, perform the following:

1. Open the KPanel S as described in Chapter 10.2: Opening and Closing for Initial Assembly, step 2.
2. Insert the cable through the cable entry point on the rear cover.
3. Remove the nut and washer from the ground stud
4. Insert the ground cables ring over the ground stud and fasten using the nut and washers removed in step 3.
5. Secure the ground cable using the cable relief bracket and cable ties to eliminate cable strain.
6. Connect interface cables to the CPU module's Interface connectors:
KPanel S-RPL CPU Module: x 2.5 GbE, 4x USB 3.2 Gen 2 and 2x DP.
7. Secure the interface cables using the cable relief bracket and cable ties to eliminate cable strain.
8. Assembly the cables to the expansion plate as described in Chapter 10.4: Assembling the Expansion Plate Options
9. Before connecting the power cable, ensure disconnection from the external power source physically or by using a disconnection device (fuse or circuit breaker rated in to meet the wire cross-section and electrical specification of the KPanel S).
10. Wiring the power cable with the delivered mating power connector as described in Chapter 10.5: Wiring the Mating Power Connector. Connect the wired mating connector to the Power IN connector (X101) and secure the wired mating connector using the two connector screws.
11. Secure the power cable using the cable relief bracket and cable ties to eliminate cable strain.
12. Close the KPanel S as described in Chapter 10.2: Opening and Closing for Initial Assembly, step 3.

10.4. Assembling the Removable Expansion Plate Options

The KPanel S is delivered with all ordered expansion plate options assembled and internally connected. Users are only required to connect any cables accessing the expansion plate devices through the cable entry point. The expansion plate is designed and positioned to enable users to access the devices on the expansion plate without having to remove the expansion plate. However, in some situations it may be easier to release the expansion plate and move it upwards slightly to gain better access to the expansion plate option. This can be performed without removing any cables attached to the expansion plate.



The expansion plate is only installed if the user's hardware configuration includes an expansion plate option.

To release the expansion plate to gain better access to the expansion plate option, perform the following:

1. Open the KPanel S as described in Chapter 10.2: Opening and Closing for Initial Assembly, step 2.
2. Unscrew the two knurled screws, lift the expansion plate slightly out of the retaining bracket to connect the cable and then reinsert the expansion plate into the retaining bracket and fasten the two knurled screws.
3. Close the KPanel S as described in Chapter 10.2: Opening and Closing for Initial Assembly, step 3.

10.5. Wiring the Mating Power Connector

The power cable is not part of the delivery and must be provided by the user. Use copper wire only. The user is responsible for wiring the mating power connector included in the delivery.

NOTICE

Wire the mating power connector clearly by marking the supply wires (+/-) to ensure a safe connection.



The power cable is not part of the delivery and must be provided by the user. Use copper wire only.

Figure 19: Power IN and Mating Power Connector

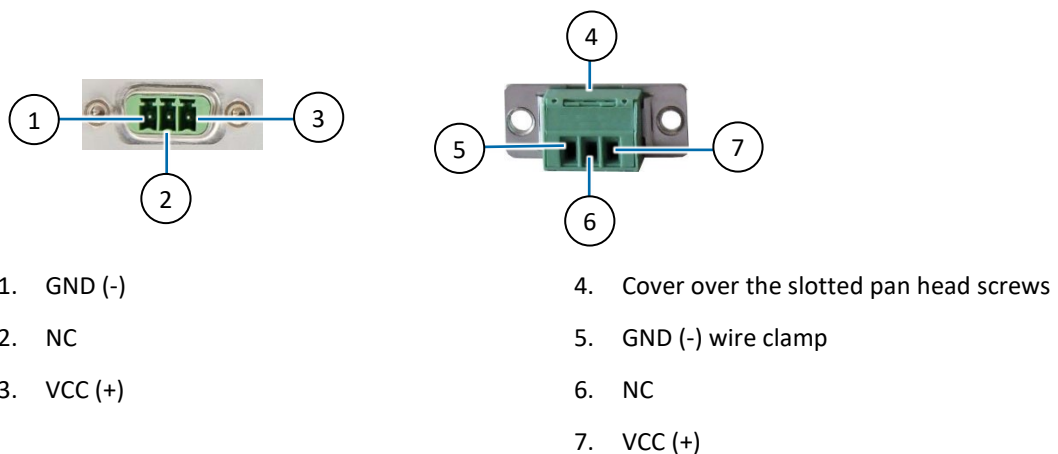

To wire the supplied 3-pin mating power connector (PSC 1.5/ 3-F) perform the following:

1. Cut three (1 mm²) AWG18 isolated wires to the required length and strip each end 5 mm to 7 mm.

2. Twist the striped wire-ends and provide them with ferrules.
3. Opening the mating power connector's cover to access the slotted pan head screws
4. Loosen the slotted pan head screws far enough to insert the end of the prepared wires. Make sure that you insert the wires with the right polarity (+/-).
5. Fasten the screws to secure the wires and close the cover.

11/ Starting Up

11.1. Before Starting Up

Before connecting the KPanel S-RPL to an external power source, read the instructions in this user guide and observe the safety instructions in Chapter 2/ General Safety Instructions.

Operated Closed

⚠ CAUTION

It is only ensured that operators do not have access to internal components during operation if the product is closed and the rear cover fastened using all ten captures screws.

External Power Source

⚠ CAUTION

Only connect the product to an external power source providing the voltage type (AC or DC) and the input power (max. current) specified on the Kontron Type Label.

The external power source must meet the requirements of ES1/PS2 according to IEC/UL 62368-1.

Disconnection Device

⚠ CAUTION

Connect the external power cable to an external power source meeting the product's electrical specification and using a disconnection device (fuse or circuit breaker) rated in accordance with the product's wire cross-section.

Damage

⚠ CAUTION

Do not switch on or handle the product if there is any visible damage.
Ensure that the ground and power cable have no visible damage.

11.2. Starting Up

The KPanel S comes factory configured including a pre-installed Operating System (OS) and all the necessary drivers, enabling full operation after assembly and installation.

The KPanel S switches on automatically when connected to a power source. KPanel S variants that include a power button only switch on after the power button is pressed.

12/ Connector Pin Assignment

The KPanel S-RPL internal connectors on the CPU module are described in the chapter.

12.1. Power IN Connector (X101)

Table 14: Power IN Connector Pin Assignment

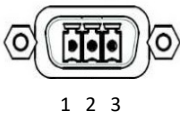
3-Pin Phoenix PSC 1.5/3-M	Pin	Signal Name	Description
	1	GND (-)	0 VDC
	2		
	3	VCC (+)	12 VDC to 34 VDC
Mating Connector	3-pin Phoenix PSC 1.5/ 3-F		

Include a Functional Earth

⚠ CAUTION

No isolation between Power IN, GND and the KPanel S display housing. Users must include a functional earth.



The KPanel S switches on automatically when the POWER IN connector (X101) is connected to a 12 VDC to 34 VDC (max. 36 VDC) power source that meets the product's safety requirements.

Note: KPanel S variants that include a power button only switch on after the power button is pressed.

12.2. 2.5 GbE Ethernet Ports (X102, X103)

Table 15: 2.5 GbE Ethernet Port Pin Assignment

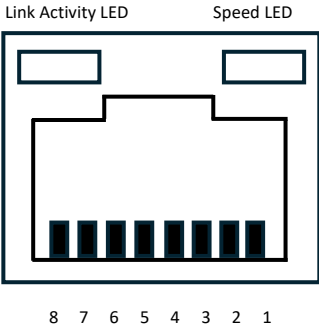
RJ45 (female) X102	Pin	Signal Name
	1	TX1+
	2	TX1-
	3	TX 2+
	4	TX 3+
	5	TX 3-
	6	TX 2-
	7	TX 4+
	8	TX 4-

Left LED: Link Activity		Right LED: Speed	
Off	Link down	Off	10/100 Mbps
Yellow Flashing	Link up and active	Orange	1000 Mbps
Yellow	Link up and no activity	Green	2500 Mbps

Signal	Description
TX1+ / TX1-	In MDI mode, this is the first pair in 2.5GBase-T and 1000Base-T, i.e. the BI_DA+/- pair, and is the transmit pair in 10Base-T and 100Base-TX. In MDI crossover mode, this pair acts as the BI_DB+/- pair, and is the receive pair in 10Base-T and 100Base-TX.
TX2+ / TX2-	In MDI mode, this is the second pair in 2.5GBase-T and 1000Base-T, i.e. the BI_DB+/- pair, and is the receive pair in 10Base-T and 100Base-TX. In MDI crossover mode, this pair acts as the BI_DA+/- pair, and is the transmit pair in 10Base-T and 100Base-TX.
TX3+ / TX3-	In MDI mode, this is the third pair in 2.5GBase-T and 1000Base-T, i.e. the BI_DC+/- pair. In MDI crossover mode, this pair acts as the BI_DD+/- pair.
TX4+ / TX4-	In MDI mode, this is the fourth pair in 2.5GBase-T and 1000Base-T, i.e. the BI_DD+/- pair. In MDI crossover mode, this pair acts as the BI_DC+/- pair.



To achieve the specified performance, Category 5 twisted pair cables must be used with 10/100 MByte and Category 5E, 6 or 6E with 1 Gbit/2.5 Gbit Ethernet networks.



Connected only to internal Ethernet networks located within the facility and not classified as TNV circuits.

12.3. USB 3.2 Gen 2 Ports (X104 - X107)

Table 16: USB 3.2 Gen 2 Type A Port Pin Assignment

USB Type A	Pin	Signal Name	Description
	1	+USB_VCC	+5 V power supply for USB device
	2	USB_D-	USB 2.0 differential pair (-)
	3	USB_D+	USB 2.0 differential pair (+)
	4	GND	Ground
	5	USB_RX-	USB 3.2 receiver differential pair (-)
	6	USB_RX+	USB 3.2 receiver differential pair (+)
	7	GND	Ground
	8	USB_TX-	USB 3.2 transmitter differential pair (-)
	9	USB_TX+	USB 3.2 transmitter differential pair (+)



Use only HiSpeed USB cable specified in the USB 3.2 Gen 2 standard.



The four USB 3.2 Gen 2 ports are backwards compatible with earlier USB 3.0 and USB 2.0 version-

12.4. DisplayPorts (X108, X109)

Table 17: DisplayPort Pin Assignment

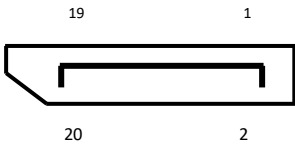
20-pin Standard DP (female)	Pin	Signal Name	Pin	Signal Name
	1	ML_Lane0+	11	GND
	2	GND	12	ML_Lane3-
	3	ML_Lane0-	13	Config1
	4	ML_Lane1+	14	Config2
	5	GND	15	AUX_CH+
	6	ML_Lane1-	16	GND
	7	ML_Lane2+	17	AUX_CH-
	8	GND	18	Hot_Plug
	9	ML_Lane2-	19	GND
	10	ML_Lane3+	20	DP_PWR

Signal Name	Description
ML_Lane# +/-	DisplayPort Lane # transmitter differential pair (+/-)
Aux CH +/-	DisplayPort Auxiliary channel differential pair (+)
Hot Plug	DisplayPort hot plug detect (HPD)
Config#	Connect to Ground directly or via a pulldown device
GND	Ground signal
PWR	Power supply signal for connector



DisplayPort ++ supports the use of passive adapters to connect to HDMI or DVI.

12.5. Rear Cover Connectors

12.5.1. USB 3.2 Gen 2 Type A Port (option)

Table 18: USB 3.2 Gen 2 Type A Port Pin Assignment

USB Type A	Pin	Signal Name	Description
	1	+USB_VCC	+5 V power supply for USB device
	2	USB_D-	USB 2.0 differential pair (-)
	3	USB_D+	USB 2.0 differential pair (+)
	4	GND	Ground
	5	USB_RX-	USB 3.2 receiver differential pair (-)
	6	USB_RX+	USB 3.2 receiver differential pair (+)
	7	GND	Ground
	8	USB_TX-	USB 3.2 transmitter differential pair (-)
	9	USB_TX+	USB 3.2 transmitter differential pair (+)



USB 3.2 ports led to the rear cover, are no longer available on the interface panel.



Use only HiSpeed USB cable specified in the USB 3.2 Gen 2 standard.

12.6. Antenna (on request)

Avoid Antenna RF Exposure by:

⚠ CAUTION

- Avoid placing the antenna near people, minimum distance 20 cm.
- Avoid pointing the antenna at people.
- Keep a safe distance from the antenna especially when transmitting.

NOTICE

RP-SMA and SMA Antenna are not Interchangeable!

RP-SMA and SMA connectors and antenna are not electrically compatible. Incorrect connection may result in an insufficient connection or destroy the center pin.





Kontron recommends using Kontron's reference antenna chosen to meet RF performance requirements and with a nominal impedance of 50 ohms.



The reference antennas included in the delivery are available in Table 2: List of Accessories and Spare Parts.



12.6.1. Wi-Fi/BT® Antenna (on request)

Table 19: Wi-Fi/BT® Antenna Pin Assignment

Antenna Connector	Antenna Description	
<p>Wi-Fi/BT® Connector</p>  <p>RP-SMA (female) with center pin and outer thread.</p>	<p>Wi-Fi Antenna</p>  <p>RP-SMA (male) antenna with pin socket and inner thread.</p>	

12.6.2. Cellular LTE Antenna (on request)

Table 20: LTE Antenna Pin Assignment

Antenna Connector	Antenna Description	
<p>LTE Cellular connector</p>  <p>SMA (female) connector with pin socket & outer thread</p>	<p>LTE Cellular Antenna</p>  <p>SMA (male) antenna with Center pin & inner thread</p>	



Cellular LTE requires a Cellular network SIM card to be provided by the user. The SIM card inserts into a SIM card slot located internally on top of the CPU module.

12.7. Removable Expansion Plate Connector



Not all expansion options are available simultaneously.

12.7.1. RTC Lithium Battery Connector

Table 21: Standard RTC Lithium Battery Connector Pin Assignment

2-pin, Connector	Pin	Signal Name	Description
	1	+VRTC	Real-time clock backup lithium battery input
	2	GND	Ground

12.7.2. Automotive RTC Lithium Battery Connector

Table 22: Automotive RTC Lithium Battery Connector Pin Assignment

2-pin, Connector	Pin	Signal Name	Description
	1	+VRTC	Real-time clock backup lithium battery input
	2	GND	Ground

12.7.3. Serial Port Connector

Table 23: Serial Port (RS232) Connector Pin Assignment

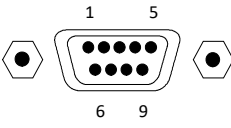
9-pin D-SUB (male)	Pin	RS232	Description
	1	DCD	Data Carrier Detect signal
	2	RxD	Received Data, receives data from the communications link.
	3	TxD	Transmitted Data, sends data to the communications link.
	4	DTR	Data Terminal Ready indicates UART is ready to establish a link.
	5	GND	GND signal
	6	-	-
	7	-	-
	8	-	-
	9	-	-

13/ BIOS

The KPanel S-RPL uses the AMI Aptio V uEFI BIOS based on the Unified Extensible Firmware Interface (uEFI) specification and the Intel® Platform Innovation Framework for EFI. The uEFI BIOS preferences are preset and do not require further adjustment for operation.

The UEFI BIOS Setup menus and available selections are open to change. For specific information on the BIOS for your , visit Kontron's [Customer Section](#). and access the FlatClient PRO RPL information.



UEFI only! No legacy support and no Master Boot Record (MBR) installation.



For the latest uEFI BIOS Information, visit Kontron's [Customer Section](#) to download the BIOS. If the information you require is not available within the Customer Section, contact [Kontron Support](#).

13.1. Starting the uEFI BIOS

The uEFI BIOS's Setup program provides quick and easy access to the individual function settings for control or modification of the uEFI BIOS configuration

Use the navigation hot keys, to navigate the BIOS. The hot key legend bar is located at the bottom right of each Setup screen. For a list of navigation hot keys, see Table 24: Navigation Hot Keys.

Table 24: Navigation Hot Keys

Sub-screen	Description
<F1>	<F1> key invokes the General Help window
<->	<Minus> key selects the next lower value within a field
<+>	<Plus> key selects the next higher value within a field
<F2>	<F2> key loads previous values
<F3>	<F3> key loads optimized defaults
<F4>	<F4> key Saves and Exits
<←> or <→>	<Left/Right> arrows select major Setup menus on menu bar, for example, Main or Advanced
<↑> or <↓>	<Up/Down> arrows select fields in the current menu, for example, Setup function or sub-screen
<ESC>	<ESC> key exits a major Setup menu and enters the Exit Setup menu Pressing the <ESC> key in a sub-menu displays the next higher menu level
<RETURN>	<RETURN> key executes a command or selects a submenu

To start the uEFI BIOS Setup program, follow the steps below:

1. Switch on the KPanel S.
2. Wait until the first characters appear on the screen (POST messages or splash screen).
3. Press the key.
4. If the uEFI BIOS is password-protected, a request for password will appear. Enter either the User Password or the Supervisor Password, press <RETURN>, and proceed with step 5.
5. The BIOS setup utility appears in the Main menu.

6. Use the Navigation Hot Keys arrow keys to navigate to the required Setup menu to “change,” or “reset,” settings.
7. Navigate using Navigation Hot Key arrow keys to the “Save & Exit” Setup menu and select “Save Changes”.

13.2. BIOS Update

To ensure compatibility with new OS, hardware, software or to integrate new BIOS functions Kontron recommends performing regular BIOS updates. Additionally, if a problem cannot be solved using a new driver, Kontron recommends updating the BIOS.

For the latest BIOS downloads and release information, visit Kontron’s [Customer Section](#). Select the latest version of the BIOS Update and the preferred method to update the BIOS with instructions.



To discover your current BIOS version, refer to the Kontron BIOS Version number within the Main menu.

13.3. Setup Menus

The Setup menus listed in the selection bar at the top of the screen are:

- › Main
- › Advanced
- › Chipset
- › Security
- › Boot
- › Save & Exit

The current active menu and active BIOS Setup item are highlighted in white. Use the left and right arrow keys to select the Setup menus.

Each Setup menu is made up of two main frames. The left frame displays all available functions. Configurable functions are displayed in blue. Functions displayed in grey provide information about the status or the operational configuration. The right frame displays an explanation of the respective function in a help window.

Advanced Setup Menu – Caution when Changing

NOTICE

Making changes within the Advanced Setup menu without understanding the full implications may cause system malfunction.

Kontron recommends users to make changes only when the user is sure of the impact.



Functions displayed in “grey” in the following setup menus and tables provide information about the status or the operational configuration of the product but are not selectable and not changeable.

13.4. Main Setup Menu

The Main Setup menu provides basic system information and functions for setting the system time and date.

Figure 20: Main Setup Menu Example

Aptio Setup - AMI					
Main	Advanced	Chipset	Security	Boot	Save & Exit
Product Information					
Product Name		3.5-SBC-RPL			
BIOS Information					
BIOS Vendor		American Megatrends			
Core Version		5.32			
Compliance		UEFI 2.9 ; PI 1.7			
Kontron BIOS Version (FLATCRPL100)		RPLUVEXR.140 (x64)			
Access Level		Administrator			
FPS Information					
FSP version		0C.01.DE.40			
RC version		0C.00.DE.40			
Build Date					
FSP Mode		Dispatch Mode			
Processor Information					
Name		RaptorLake ULT			
Type		13 th Gen Intel® Core™ i3-1315UE			
Speed		1200 MHz			
ID		0xB06A3			
Stepping		Q0			
Package		Not Implemented Yet			
Number of Efficient-cores		4Core(s) / 4Thread(s)			
Microcode Revision		4121			
GT Info		0xA7A9			
IGFX GOP Version		21.0.1065			
Memory RC Version		0.0.4.224			
Total Memory		16384 MB			
Memory Frequency		5200 MHz			
PCH Information					
Name		PCH-P			
PCH SKU		RPL-P: Premium			
Stepping		A1			
ChipsetInit Base Revision		2			

Aptio Setup - AMI					
Main	Advanced	Chipset	Security	Boot	Save & Exit
ChipsetInit OEM Revision		0			
Package		Not Implemented Yet			
TXT Capability of Plattform/PCH		Unsupported			
Production Type		Production			
Dual Output Fast Read support		Supported			
Read ID/Status Clock Freq		50 MHz			
Write and Erase Clock Freq		50 MHz			
Fast Read Clock Freq		50 MHz			
Fast Read support		Supported			
Number of Components		1 Component			
SPI Component 0 Density		32 MB			
eSPI Flash Sharing Mode		G3			
EC PECI Mode		Legacy PECI mode			
ME FW Version		16.1.30.2307			
ME Firmware SKU		Consumer SKU			
PMC FW Version		160.1.0.1030			
System Language		[English]			
▶ Platform Information					
Board Information					
Product Name		3.5-SBC-RPL			
Serial#		XXXXXXXX			
UUID		XXXXXXXX-XXXX-XXXX-XXXX-XXXXXXXXXXXX			
KSC Information					
Controller		KSC Main Controller			
Operating Mode		Normal			
Board Name		3.5-RPL			
Platform ID		000C			
KSC Spec. Version		1.20			
BIOS Protocol Version		2.3.1			
BIOS SW Spec. Version		1.18			→ ←: Select Screen
Core Firmware Version		1.4.1 Release			↑ ↓: Select Item
Board Firmware Version		1.1.0 Release			Enter: Select
SCM Info		30-F4-D1-45			+/-: Change Opt.
Boot counter		N/A			F2: Previous Values
					F3: Optimized Defaults
System Date		xxx xx/xx/xxxx			F4: Save & Reset
System Time		xx:xx:xx			ESC: Exit

13.5. Advanced Setup Menu

Figure 21: Advanced Setup Menu Example

Aptio Setup - AMI					
Main	Advanced	Chipset	Security	Boot	Save & Exit
Configurable TDP Mode			[Nominal]		
In-Band ECC Support			[Disabled]		
Compliance Test Mode			[Disabled]		
HD Audio			[Enabled]		
Power Mode Selection			AT Mode		
Resore AC Power Loss			Power Off		
Power Saving Mode			[Disabled]		
ME FW Image Re-Flash			[Disabled]		
Unconfigure ME			[Disabled]		
AMT BIOS Feature			[Disabled]		
▶ Display Configuration					
▶ Trusted Computing					
▶ ACPI Settings					
▶ Miscellaneous					
▶ MEBx					
▶ H/W Monitor					
▶ S5 RTC Wake Settings					
▶ Serial Port Console Redirection					
▶ SIO Configuration					
▶ USB Configuration					
▶ Network Stack Configuration					
▶ NVME Configuration					
▶ CH7513A Configuration					
▶ F81435 Configurations					
▶ Intel® Ethernet Controller I226-LM – XX:XX:XX:XX:XX:XX					
▶ Intel® Ethernet Controller I226LM – XX:XX:XX:XX:XX:XX					
▶ Driver Health					
				→ ←: Select Screen	
				↑ ↓: Select Item	
				Enter: Select	
				+/-: Change Opt.	
				F1: General Help	
				F2: Previous Values	
				F3: Optimized Defaults	
				F4: Save & Reset	
				ESC: Exit	

Table 25: Advanced Setup Menu Sub-screens

Sub-screen	BIOS Default	Possible Settings
Configurable TDP Boot Mode	Nominal	Nominal, Low Level, High Level
In-Band ECC Support	Disabled	Disabled, Enabled
Compliance Test Mode	Disabled	Disabled, Enabled
HD Audio	Enabled	Disabled, Enabled
Power Mode Selection	ATX Mode	
Resore AC Power Loss	Power Off	Power Off, Last State
Power Saving Mode	Disabled	Disabled, Enabled
ME FW Image Re-Flash	Disabled	Disabled, Enabled
Unconfigure ME	Disabled	Disabled, Enabled
AMT BIOS Features	Disabled	Disabled, Enabled

Display Configuration

Sub-screen	BIOS Default	Possible Settings
Display Configuration		
VBT Select	DP	DP, HDMI
Primary Display	IGFX	Auto, IGFX, PEG Slot; PCH PCI
Internal Graphics	Enabled	
Aperture Size	256MB	128MB, 256MB, 512MB, 1024MB

Trusted Computing

Sub-screen	BIOS Default	Possible Settings
TPM 2.0 Device Found		
Firmware Version	16.13	
Vendor	IFX	
Security Device Support	Enable	Disabled, Enable
Active PCR banks	SHA256	
Available PCR banks	SHA256,SHA384	
SHA256 PCR Bank	Enabled	Disabled, Enabled
SHA384 PCR Bank	Disabled	Disabled, Enabled
Pending Operation	None	None, TPM Clear
Platform Hierarchy	Enabled	Disabled, Enabled

Sub-screen	BIOS Default	Possible Settings
Storage Hierarchy	Enabled	Disabled, Enabled
Endorsement Hierarchy	Enabled	Disabled, Enabled
Physical Presence Spec Version	1.3	1.2, 1.3
TPM 2.0 InterfaceType	TIS	
Device Select	Auto	TPM 1.2, TPM 2.0, Auto

ACPI Settings

Sub-screen	BIOS Default	Possible Settings
ACPI Settings		
Enable ACPI Auto Configuration	Disabled	Disabled, Enabled
Enable Hibernation	Enabled	Disabled, Enabled
ACPI Sleep State	S3 (Suspend to RAM)	Suspend Disabled, S3 (Suspend to RAM)

Miscellaneous

Sub-screen	BIOS Default	Possible Settings
Miscellaneous Configuration		
▶ Present DIO in BIOS		
GPIO OS usable	GPIO 0 – GPIO 7	All available GPIO, GPIO 0 – GPIO 7
Control DIO in BIOS	Disabled	Disabled, Enabled
▶ Control KSC firmware		
Lock FW update access	Enabled	Disabled, Enabled
▶ KSC OTP area control		
KSC OTP access lock	Enabled	Disabled, Enabled
▶ Update KSC firmware		
Auto update KSC FW	Enabled	Disabled, Enabled
▶ Generic eSPI Decode Rangers		
Generic LPC via eSPI Decode 1	Disabled	Disabled, Enabled
▶ Watchdog		
Auto-reload	Disabled	Disabled, Enabled
Global Lock	Disabled	Disabled, Enabled
WDT Strobe	Disabled	Disabled, Enabled
Stage 1 Mode	Disabled	Disabled, Reset, Delay, WDT Signal only
Reset Button Behavior	Chipreset	Chipset Reset, Power Cycle

Sub-screen	BIOS Default	Possible Settings
I2C Speed	100 KHz	100 KHz, 400 KHz, 1 MHz
On-board I2C Mode	Multimaster	Multimaster, Busclear
Manufacturing Mode	Disabled	
BIOS Test Mode	Disabled	
Last system reset through	Power-on reset	
PCIe Wake	Enabled	Disabled, Enabled
On-board EEPROM Write Protect	WP Enabled	WP Disabled, WP Enabled

MEBX

Sub-screen	BIOS Default	Possible Settings
Intel® ME Password ^[1]		

^[1] Submenu is only accessible when “AMT BIOS Features” is enable

H/W Monitor

Sub-screen	BIOS Default	Possible Settings
KSC based H/W Monitor		
Temperature sensors:		
#1: CPU Temp	x xxx.x C	
#2: PCH Temp	x xxx.x C	
#3: System Temp	x xxx.x C	
Voltage sensors:		
#1: V_IN	xx.x V	
#1: 12V_S0	xx.x V	
#1: 5V_S0	xx.x V	
#1: 3V3_S0	xx.x V	
#1: 3V_BAT	xx.x V	
Fan speed & control:		
#1: CPU FAN	x RPM	
Fan Control	Auto	Disabled, Manual, Auto
Signal Filter Control	Auto	Disabled, Manual, Auto
Signal Filer	Enabled	
Fan Pulse	Auto	Auto, 1, 2, 3, 4, 5, 6, 7, 8

Sub-screen	BIOS Default	Possible Settings
Fan Pulse	2	
Fan Speed Control	Auto	Auto, 1, 2, 3, 4, 5, 6, 7, 8
Fan Speed Control	Normal	
Reference Temperature	All Temperatures	#1: CPU Temp, #2: PCH Temp, #3: System Temp, All Temperatures
▶ Fan Trip Point Table		
Fan 1 Automode	Internal table	Internal table, User table

S5 RTC Wake Settings

Sub-screen	BIOS Default	Possible Settings
Wake system from S5	Disabled	Disabled, Fixed Time, Dynamic Time

Serial Port Console Redirection (COM0, COM1, EMS)

Sub-screen	BIOS Default	Possible Settings
COM0		
Console Redirection	Disabled	Disabled, Enabled
▶ Console Redirection Settings		
Terminal Type	ANSI	VT100, VT100Plus, VT-UTF8, ANSI
Bits per second	115200	9600, 19200, 38400, 57600, 115200
Data Bits	8	7, 8
Parity	None	None, Even, Odd, Mark, Space
Stop Bits	1	1, 2
Flow Control	None	None, Hardware RTS/CTS
CT-UTF8 Combo Key Support	Enabled	Disabled, Enabled
Recorder Mode	Disabled	Disabled, Enabled
Resolution 100x31	Disabled	Disabled, Enabled
Putty KeyPad	VT100	VT100, LINUX, XTERMR6, SCO, ESCN, VT400
COM1		
Console Redirection	Disabled	Disabled, Enabled
▶ Console Redirection Settings		
Terminal Type	ANSI	VT100, VT100Plus, VT-UTF8, ANSI
Bits per second	115200	9600, 19200, 38400, 57600, 115200
Data Bits	8	7, 8

Sub-screen	BIOS Default	Possible Settings
Parity	None	None, Even, Odd, Mark, Space
Stop Bits	1	1, 2
Flow Control	None	None, Hardware RTS/CTS
CT-UTF8 Combo Key Support	Enabled	Disabled, Enabled
Recorder Mode	Disabled	Disabled, Enabled
Resolution 100x31	Disabled	Disabled, Enabled
Putty KeyPad	VT100	VT100, LINUX, XTERMR6, SCO, ESCN, VT400
Legacy Control Redirection		
▶ Legacy Console Redirection Settings		
Serial Port for Out-of-Band Management / Windows Emergency Management Services (EMS)		
Console Redirection EMS	Disabled	Disabled, Enabled
▶ Console Redirection Settings		
Out-of-Band Mgmt Port	COM0	COM0 COM1
Terminal Type EMS	VT-UTF8	VT100, VT100Plus, VT-UTF8, ANSI
Bits per second EMS	115200	9600, 19200, 57600, 115200
Flow Control EMS	None	None, Hardware RTS/CTS
Data Bits EMS	8	
Parity EMS	None	
Stop Bits EMS	1	

SIO Configuration (Serial Port 0, Serial Port 1)

Sub-screen	BIOS Default	Possible Settings
AMI SIO Driver Version: A5.19.00		
WARNING: Logical Device state on the left side of the control reflects the current Logical Device state. Changes made during Setup Session will be shown after you restart the system.		
Super IO Chip Logical Device(s) Configuration		
▶ [*Active*] Serial Port 0		
Serial Port 0 Configuration		
Use This Device	Enabled	Disabled, Enabled
Logical Device Settings:		
Current: IO=3F8h; IRQ=4;		

Sub-screen	BIOS Default	Possible Settings
Possible:	Use Automatic Settings	Use Automatic Settings IO=3F8h; IRQ=4; IO=3F8h; IRQ=4; IO=2F8h; IRQ=3
Warning: Disabling SIO Logical Device may have unwanted side effects. PROCEED WITH CAUTION.		
▶ [*Active*] Serial Port 1		
Serial Port 1 Configuration		
Use This Device	Enabled	Disabled, Enabled
Logical Device Settings:		
Current: IO=2F8h; IRQ=3;		
Possible:	Use Automatic Settings	Use Automatic Settings IO=2F8h; IRQ=3; IO=2F8h; IRQ=3; IO=3F8h; IRQ=4
Warning: Disabling SIO Logical Device may have unwanted side effects. PROCEED WITH CAUTION.		

USB Configuration

Sub-screen	BIOS Default	Possible Settings
USB configuration		
USB Module Version 34		
USB Controllers:		
2 XHCIs		
USB Devices:		
xxxxxxxx		
Legacy USB Support	Enabled	Disabled, Enabled, Auto
XHCI Hand-off	Disabled	Disabled, Enabled
USB Mass Storage Driver Support	Enabled	Disabled, Enabled
USB hardware delays and time-outs:		
USB transfer time-out	20 sec	1 sec, 5 sec, 10 sec, 20 sec

Sub-screen	BIOS Default	Possible Settings
Device reset time-out	20 sec	10 sec, 20 sec, 30 sec, 40 sec
Device power-up delay	Auto	Auto, Manuel

Network Stack Configuration

Sub-screen	BIOS Default	Possible Settings
Network Stack	Disabled	Disabled, Enabled
IPv4 PXE Support	Disabled	Disabled, Enabled
IPv4 HTTP Support	Disabled	Disabled, Enabled
IPv6 PXE Support	Disabled	Disabled, Enabled
IPv6 HTTP Support	Disabled	Disabled, Enabled
PXE boot wait time	0	0-5
Media detect count	1	1-50

NVME Configuration

Sub-screen	BIOS Default	Possible Settings
NVMe Configuration		
No NVME Device Found		

CH7513A Configuration

Sub-screen	BIOS Default	Possible Settings
CH7513A Configuration (DP/eDP to LVDS Converter)		
LFP Selection	edp	Disabled, LVDS, eDP

F81435 Configurations

Sub-screen	BIOS Default	Possible Settings
F81435 Configurations (Multiprotocol RS232/RS422/RS485 Transceiver)		
COM1 Mode Selection	RS232	RS422 Single Master, RS232, RS485 with Auto Flow Control, RS422 Multi Master
COM1 Transceiver	Normal mode	Shut down mode, Normal mode
COM1 Internal Terminator Switch Control	Terminator switch is disabled.	Terminator switch is disabled.

Sub-screen	BIOS Default	Possible Settings
		Terminator switch is enabled.
COM1 External Terminator Switch Control	Terminator switch is disabled.	Terminator switch is disabled. Terminator switch is enabled.
COM2 Mode Selection	RS232	RS422 Single Master, RS232, RS485 with Auto Flow Control, RS422 Multi Master
COM2 Transceiver	Normal mode	Shut down mode, Normal mode
COM2 Internal Terminator Switch Control	Terminator switch is disabled.	Terminator switch is disabled. Terminator switch is enabled.
COM2 External Terminator Switch Control	Terminator switch is disabled.	Terminator switch is disabled. Terminator switch is enabled.

Intel Ethernet Controller

Sub-screen	BIOS Defaults	Possible Setting
Intel Ethernet Controller I226LM-XX:XX:XX:XX:XX		

Intel Ethernet Controller

Sub-screen	BIOS Defaults	Possible Setting
Intel Ethernet Controller I226LM-XX:XX:XX:XX:XX		

Drive Health

Sub-screen	BIOS Defaults	Possible Setting
▶ Intel® 2.5G Ethernet Controller 0.10.06 Healthy		
▶ Intel® Ethernet Controller 0.10.06 Healthy		
▶ Intel® 2.5G Ethernet Controller 0.10.06 Healthy		
▶ Intel® Ethernet Controller 0.10.06 Healthy		

13.6. ChipSet Setup Menu

Figure 22: Chipset Setup Menu Example

Aptio Setup - AMI					
Main	Advanced	Chipset	Security	Boot	Save & Exit
<ul style="list-style-type: none"> ▶ System Agent (SA) Configurations ▶ PCH-IO Configuration 					
				→ ←: Select Screen ↑ ↓: Select Item Enter: Select +/-: Change Opt. F1: General Help F2: Previous Values F3: Optimized Defaults F4: Save & Reset ESC: Exit F4: Save & Reset	

The following table gives more information about important setup options within the Chipset Menu.

Table 26: Chipset Setup Menu Sub-screens

System Agent (SA) Configuration

Sub-screen	BIOS Defaults	Possible Setting
System Agent (SA) Configuration		
VT-D	Supported	
▶ Graphics Configuration		
Graphics Turbo IMON Current	31	14-31
Skip Scanning of External Gfx Card	Disabled	Disabled, Enabled
Select PCIE Card	Auto	Auto, Elk Creek 4, PEG Eval
HG Delay After Power Enable	300	300
HG Delay After Hold Reset	100	100
▶ External Gfx Card Primary Display Configuration		
External Gfx Card Primary Display Configuration		

Sub-screen	BIOS Defaults	Possible Setting
GTT Size	8MB	2MB, 4MB, 8MB
PSMI SUPPORT	Disabled	Disabled, Enabled
DVMT Total Gfx Mem	256M	128M, 256M, MAX
Igfx Gsm2	0GB	0GB, 2GB, 4GB, 6GB, 8GB, 10GB, 12GB, 14GB, 16GB, 18GB, 20GB, 22GB, 24GB, 26GB, 28GB, 30GB, 32GB
Intel Graphics Pei Display Peim	Disabled	Disabled, Enabled
VDD Enable	Enabled	Disabled, Enabled
Configure GT for use	Enabled	Disabled, Enabled
RC1p Support	Disabled	Disabled, Enabled
PAVP Enable	Enabled	Disabled, Enabled
Cdynmax Clamping Enable	Disabled	Disabled, Enabled
Cd Clock Frequency	Max CdClock freq based on Reference Clk	192 Mhz, 307.2 Mhz, 556.8 Mhz, 652.8 Mhz, Max CdClock freq based on Ref. Clk
Enable Display Audio Link in Pre-OS	Disabled	Disabled, Enabled
IUER Button Enable	Disabled	Disabled, Enabled
▶ LCD Control		
LCD Panel Type	VBIOS Default	VBIOS Default 640x480 LVDS 800x600 LVDS 1024x768 LVDS 1280x1024 LVDS 1400x1050 LVDS 1400x1050 LVDS 1600x1200 LVDS 1280x768 LVDS 1280x1050 LVDS 1680x1050 LVDS 1920x1200 LVDS 1600x900 LVDS 1280x800 LVDS 1280x600 LVDS 2048x1536 LVDS 1366x768 LVDS
Panel Scaling	Auto	Auto, Off, Force Scaling
Backlight Control	PWM Normal	PWM Inverted, PWM Normal
Active LFP	eDP Port-A	No eDP, eDP Port-A
Panel Color Depth	18 Bit	18 Bit, 24 Bit

Sub-screen	BIOS Defaults	Possible Setting
Backlight Brightness	255	255
▶ Intel® Ultrabook Event Support		
IUER Slate Enable	Disable	Disabled, Enabled
IUER Dock Enable	Disable	Disabled, Enabled
VT-d	Enabled	Disabled, Enabled
Above 4GB MMIO BIOS assignment	Enabled	Disabled, Enabled

PCH-IO Configuration

Sub-screen	BIOS Defaults	Possible Setting
PCH-IO Configuration		
▶ PCI Express Configuration		
DMI Link ASPM Control	Auto	Disabled, L0s, L1, L0L1, Auto
Port8xh Decode	Disabled	Disabled, Enabled
PCIe function swap	Enabled	Disabled, Enabled
PCH PCIE Clock Gating	Disabled	Disabled, L0s, L1, L0L1, Auto
PCH PCIE Power Gating	Disabled	Disabled, L0s, L1, L0L1, Auto
▶ PCIe EQ settings		
PCIe EQ override	Disabled	Disabled, Enabled
PCI Express Root Port 1	Lane configured as USV/SATA/UFS	
PCI Express Root Port 2	Lane configured as USV/SATA/UFS	
PCI Express Root Port 3	Lane configured as USV/SATA/UFS	
PCI Express Root Port 4	Lane configured as USV/SATA/UFS	
▶ PCI Express Root Port 5		
PCI Express Root Port 5	Enabled	Disabled, Enabled
Connection Type	Slot	Built-in, Slot
ASPM	Auto	Disabled, L1, Auto
L1 Substates	L1.1 & L1.2	Disabled, L1.1, L1.1 & L1.2
L1 Low	Enabled	Disabled, Enabled
ACS	Enabled	Disabled, Enabled

Sub-screen	BIOS Defaults	Possible Setting
PTM	Enabled	Disabled, Enabled
DPC	Disabled	Disabled, Enabled
EDPC	Enabled	Disabled, Enabled
URR	Disabled	Disabled, Enabled
FER	Disabled	Disabled, Enabled
NFER	Disabled	Disabled, Enabled
CER	Disabled	Disabled, Enabled
SEFE	Disabled	Disabled, Enabled
SENF	Disabled	Disabled, Enabled
SECE	Disabled	Disabled, Enabled
PME SCI	Enabled	Disabled, Enabled
Hot Plug	Disabled	Disabled, Enabled
Advanced Error Reporting	Enabled	Disabled, Enabled
PCIe Speed	Auto	Auto, Gen1, Gen2, Gen3
Transmitter Half Swing	Disabled	Disabled, Enabled
Detect Timeout	0	0-65535
Extra Bus Reserved	0	0-7
Reserved Memory	10	1-20
Reserved I/O	4	4-20
PCH PCIe LTR Configuration		
LTR	Enabled	Disabled, Enabled
Snoop Latency Override	Auto	Disabled, Manual, Auto
Non Snoop Latency Override	Auto	Disabled, Manual, Auto
LTR Lock	Disabled	Disabled, Enabled
Peer Memory Write Enable	Disabled	Disabled, Enabled
PCI Express Root Port 6	Shadowed by x2/x4 port	
▶ PCI Express Root Port 7	(refer to PCI Express Port 5)	
▶ PCI Express Root Port 8	(refer to PCI Express Port 5)	
▶ PCI Express Root Port 9	(refer to PCI Express Port 5)	
▶ PCI Express Root Port 10	(refer to PCI Express Port 5)	
PCI Express Root Port 11	Lane configured as USV/SATA/UFS	
PCI Express Root Port 12	Lane configured as USV/SATA/UFS	

Sub-screen	BIOS Defaults	Possible Setting
▶ PCIe Clocks		
Clock0 assignment	Enabled	Platform-POR, Enabled, Disabled
ClkReq for Clock0	Platform-POR	Platform-POR, Disabled
Clock1 assignment	Enabled	Platform-POR, Enabled, Disabled
ClkReq for Clock1	Platform-POR	Platform-POR, Disabled
Clock2 assignment	Enabled	Platform-POR, Enabled, Disabled
ClkReq for Clock2	Platform-POR	Platform-POR, Disabled
Clock3 assignment	Enabled	Platform-POR, Enabled, Disabled
ClkReq for Clock3	Platform-POR	Platform-POR, Disabled
Clock4 assignment	Enabled	Platform-POR, Enabled, Disabled
ClkReq for Clock4	Platform-POR	Platform-POR, Disabled
Clock5 assignment	Enabled	Platform-POR, Enabled, Disabled
ClkReq for Clock5	Platform-POR	Platform-POR, Disabled
Clock6 assignment	Enabled	Platform-POR, Enabled, Disabled
ClkReq for Clock6	Platform-POR	Platform-POR, Disabled
Clock7 assignment	Enabled	Platform-POR, Enabled, Disabled
ClkReq for Clock7	Platform-POR	Platform-POR, Disabled
Clock8 assignment	Enabled	Platform-POR, Enabled, Disabled
ClkReq for Clock8	Platform-POR	Platform-POR, Disabled
Clock9 assignment	Enabled	Platform-POR, Enabled, Disabled
ClkReq for Clock9	Platform-POR	Platform-POR, Disabled
▶ SATA Configuration		
SATA Controller(s)	Enabled	Disabled, Enabled
SATA Mode Selection	AHCI	AHCI
SATA Test Mode	Disabled	Disabled, Enabled
Aggressive LPM Support	Enabled	Disabled, Enabled
Serial ATA Port 0	Empty	
Software Preserve	Unknown	
Port 0	Enabled	Disabled, Enabled
Hot Plug	Disabled	Disabled, Enabled
Configure as eSATA	Hot Plug supported	

Sub-screen	BIOS Defaults	Possible Setting
External	Disabled	Disabled, Enabled
Spin Up Device	Disabled	Disabled, Enabled
SATA Device Type	Hard Disk Drive	Hard Disk Drive, Solid State Drive
Topology	Unknown	Unknown, ISATA, Direct connect, Flex, M2
SATA Port 0 DevSlp	Disabled	Disabled, Enabled
DITO Configuration	Disabled	Disabled, Enabled
DITO Value	625	
DM Value	15	
Serial ATA Port 1	Empty	
Software Preserve	Unknown	
Port 1	Enabled	Disabled, Enabled
Hot Plug	Disabled	Disabled, Enabled
Configure as eSATA	Hot Plug supported	
External	Disabled	Disabled, Enabled
Spin Up Device	Disabled	Disabled, Enabled
SATA Device Type	Hard Disk Drive	Hard Disk Drive, Solid State Drive
Topology	Unknown	Unknown, ISATA, Direct connect, Flex, M2
SATA Port 1 DevSlp	Disabled	Disabled, Enabled
DITO Configuration	Disabled	Disabled, Enabled
DITO Value	625	
DM Value	15	
Serial ATA Port 2	Empty	
Software Preserve	Unknown	
Port 2	Enabled	Disabled, Enabled
Hot Plug	Disabled	Disabled, Enabled
Configure as eSATA	Hot Plug supported	
External	Disabled	Disabled, Enabled
Spin Up Device	Disabled	Disabled, Enabled
SATA Device Type	Hard Disk Drive	Hard Disk Drive, Solid State Drive
Topology	Unknown	Unknown, ISATA, Direct connect, Flex, M2
SATA Port 2 DevSlp	Disabled	Disabled, Enabled
DITO Configuration	Disabled	Disabled, Enabled

Sub-screen	BIOS Defaults	Possible Setting
DITO Value	625	
DM Value	15	
▶ USB Configuration		
xDCI Support	Disabled	Disabled, Enabled
USB2 PHY Sus Well Power Gating	Enabled	Disabled, Enabled
USB PDO Programming	Enabled	Disabled, Enabled
USB Overcurrent	Enabled	Disabled, Enabled
USB Overcurrent Lock	Enabled	Disabled, Enabled
USB Audio Offload	Enabled	Disabled, Enabled
USB Enable HSII on xHCI	Enabled	Disabled, Enabled
USB3.1 Portx Speed Selection	0	0-15
USB Port Disable Override	Disable link	Disable link, Select Per-Pin
▶ TSN GBE Configuration		
PCH LAN Controller	No GbE Region	
Port 80h Redirection	LPC Bus	LPC Bus, PCIE Bus
Enhance Port 80h LPC Decoding	Enabled	Disabled, Enabled
PCH LAN Controller	Disabled	

13.7. Security Setup Menu

Figure 23: Security Setup Menu Example

Aptio Setup - AMI					
Main	Advanced	Power	Boot	Security	Save & Exit
Password Description If ONLY the Administrator's password is set, then this only limits access to Setup and is only asked for when entering Setup If ONLY the User's password is set, then this is a power on password and must be entered to boot or enter Setup. In Setup the User will have Administrator rights. The password length must be in the following range: Minimum Length 3 Maximum length 20 Administrator Password User Password ► Secure Boot					
				→ ←: Select Screen ↑ ↓: Select Item Enter: Select +/-: Change Opt. F1: General Help F2: Previous Values F3: Optimized Defaults F4: Save & Reset ESC: Exit	

The following table gives more information about important setup options within the Security Menu.

Table 27: Security Setup Menu Sub-screen

Sub-screen	BIOS Default	Possible Settings
System Mode	Setup	
Secure Boot	Disabled	Disabled, Enabled
	Not Active	
Secure Boot Mode	Standard	Standard, Custom
► Restore Factory Keys		
► Reset to Setup Mode		
► Key Management		

Sub-screen	BIOS Default	Possible Settings
Vendor Keys	Valid	
Factory Key Provision	Disabled	Disabled, Enabled
▶ Restore Factory Keys		
▶ Reset to Setup Mode		
▶ Enroll Efi Image		
▶ Export Secure Boot variables		
Secure Boot variable		
▶ Platform Key (PK)		
▶ Key Exchange Keys		
▶ Authorized Signatures		
▶ Forbidden Signatures		
▶ Authorized TimeStamps		
▶ OsRecovery Signatures		



UEFI only! No legacy support and no Master Boot Record (MBR) installation.

13.8. Boot Setup Menu

Figure 24: Boot Setup Menu Example

Aptio Setup - AMI					
Main	Advanced	Power	Boot	Security	Save & Exit
Boot Configuration					
Setup Prompt Timeout		[1]			
Bootup NumLock State		[Off]			
Quiet Boot		[Disabled]			
Fixed Boot order		[Enabled]			
Boot Option Priorities				→ ←: Select Screen ↑ ↓: Select Item Enter: Select +/-: Change Opt. F1: General Help F2: Previous Values F3: Optimized Defaults F4: Save & Reset ESC: Exit	
Boot Option #1		[xxxxx]			
▶ UEFI Hard Disk Drive BBS Priorities					
▶ UEFI Application Boot Priorities					

The following table gives more information about important setup options within the Boot menu.

Table 28: Boot Setup Menu Sub-screens

Sub-screen	BIOS Default	Possible Settings
Boot Configuration		
Setup Prompt Timeout	1	1-65535 Displays number of seconds the firmware waits for setup activation key. (65535 (0xFFFF) means an indefinite wait)
Bootup NumLock State	Off	On, Off
Quiet Boot	Disable	Disabled, Enabled
Fixed Boot Order	Enabled	Disabled, Enabled
Boot Option Priorities		
Boot Option #1	XXXXXX	
▶ UEFI Hard Disk Drive BBS Priorities		
Boot Option #1	XXXXXX	
▶ UEFI Application Boot Priorities		
Boot Option #1	UEFI: Built-in EFI Shell	UEFI: Built-in EFI Shell, Disabled

13.9. Save and Exit Setup Menu

Figure 25: Save and Exit Setup Menu Example

Aptio Setup - AMI					
Main	Advanced	Power	Boot	Security	Save & Exit
Save Options					
Save Changes and Exit					
Discard Changes and Exit					
Save Changes and Reset					
Discard Changes and Reset					
Save Changes					
Discard Changes					
Default Options				→ ←: Select Screen	
Restore Defaults				↑ ↓: Select Item	
Save as User Default				Enter: Select	
Restore User Defaults				+/-: Change Opt.	
Boot Override				F1: General Help	
UEFI: Built-in EF Shell				F2: Previous Values	
XXXXX				F3: Optimized Defaults	
				F4: Save & Reset	
				ESC: Exit	

The following table gives more information about important setup options within the Save and Exit Menu.

Table 29: Save and Exit Setup Menu Sub-screens

Sub-screen	Description
Save Changes and Exit>	Exits system after saving changes
Discard Changes and Exit>	Exits system setup without saving changes
Save Changes and Reset>	Reset system after saving changes
Discard Changes and Reset>	Resets system setup without saving changes
Save Changes>	Saves changes made so far for any setup options
Discard Changes>	Discards changes made so far to the setup values and restore the previously saved values.
Restore Defaults>	Restores/loads standard default values for all setup options
Save as User Defaults>	Saves changes made so far as user defaults
Restore User Defaults>	Restores user defaults to all setup options
UEFI Built-in EFI shell>	Attempts to launch the built in EFI Shell

14/ Maintenance and Prevention

Before cleaning or performing maintenance on the KPanel S-RPL, read and observe the instructions in this user guide. Maintenance or repair on the KPanel S may only be carried out by skilled personnel authorized by Kontron.

Handling and Operation

⚠ CAUTION

Handling and operation of the product is permitted only for skilled personnel aware of the associated dangers within an access-controlled workplace that fulfills all necessary technical and environmental requirements.

Switch off Completely before Opening

⚠ CAUTION

To switch off completely use the power button (if provided) and remove the power cable from the external power source or disconnection device (fuse/circuit breaker) rated in accordance with the product's wire cross-section and electrical specification.

Hot Surface



The rear cover can get very hot. To avoid burns and personal injury when handling:

- › Do not touch while in operation
- › Allow to cool before handling
- › Wear protective gloves



ESD Sensitive Device!

Follow the safety instructions for components that are sensitive to electrostatic discharge (ESD). Failure to observe this warning notice may result in damage to the product or/and internal components.

Return to Kontron

NOTICE

If a problem of a technical nature occurs, Kontron recommends users to return the product to Kontron to avoid damage during maintenance. For more information, see Chapter 15.1: Returning Defective Merchandise.

14.1. Cleaning the KPanel S

Before cleaning the KPanel S, read and observe the instructions within this chapter.

14.1.1. Cleaning the Front

NOTICE

Penetration of Liquids

The display is IP65 protected and may be cleaned with a liquid cleaner.

NOTICE

Damage to Display

When cleaning the display, do not apply pressure or use an abrasive substance/cloth that might scratch or damage the display's surface.

When cleaning the front:

- › Use a clean, soft microfiber cloth.
- › Use a commercially available glass cleaner or Ethanol Alcohol.
- › Gently wipe the display with a cloth dampened with the glass cleaner.
- › Do not press on the display when cleaning.

14.1.2. Cleaning the Rear Cover

The rear cover is IP65 protected; and is dust tight and offers protection from water jets.

NOTICE

Chemical Substances

Do not use a chemical substance on the rear cover, this may damage the finish.

NOTICE

Penetration of Liquids

The display is IP65 protected and may be cleaned with a liquid cleaner.



Hot Surface

The rear cover can get very hot. To avoid burns and personal injury when handling:

- › Do not touch while in operation
- › Allow to cool before handling
- › Wear protective gloves

When cleaning the rear cover:

- › Ensure the KPanel S is not in operation and has cooled sufficiently.
- › Use a clean, soft microfiber cloth.
- › Use warm soapy water only.
- › Do not use a chemical substance when cleaning the rear cover, this may damage the lettering and varnish finish.
- › Gently wipe the rear cover with a cloth dampened with warm soapy water.
- › By persistent dirt spray water directly onto the rear cover to clean

14.2. Maintaining the KPanel S

Before Maintaining the KPanel S, read and observe the instructions within this chapter.

The removable expansion plate accommodates up to two expansion plate options that can be maintained by the user. The expansion plate is only included as part of the delivery if this option is ordered in the original hardware configuration.

The expansion plate is split into two parts whereby the bottom part is permanently reserved for the automotive RTC Lithium battery. The remaining space on the expansion plate supports all other expansion options. For Information on how to maintain the expansion plate options, refer to the relevant information within this chapter.

Figure 26: Accessing Internal Components for Maintenance

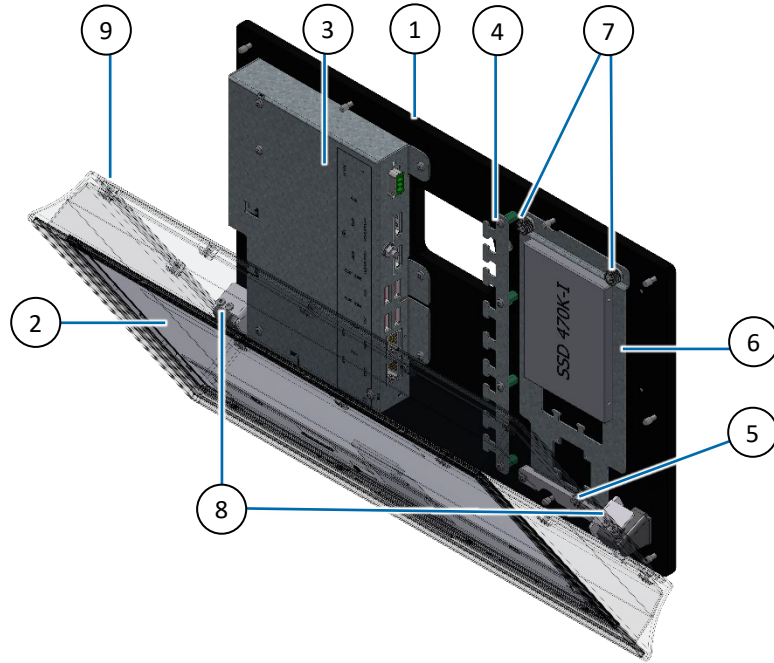

- | | |
|-----------------------------------|--------------------------------------|
| 1. Rear cover | 6. Expansion plate (removable) |
| 2. Front (shown here transparent) | 7. 2x Expansion plate knurled screws |
| 3. CPU module | 8. 2x Hinge brackets (left & right) |
| 4. Cable relief bracket | 9. Seal |
| 5. Retaining bracket | |

Figure 27: Expansion Plates (standard and with dual COM)

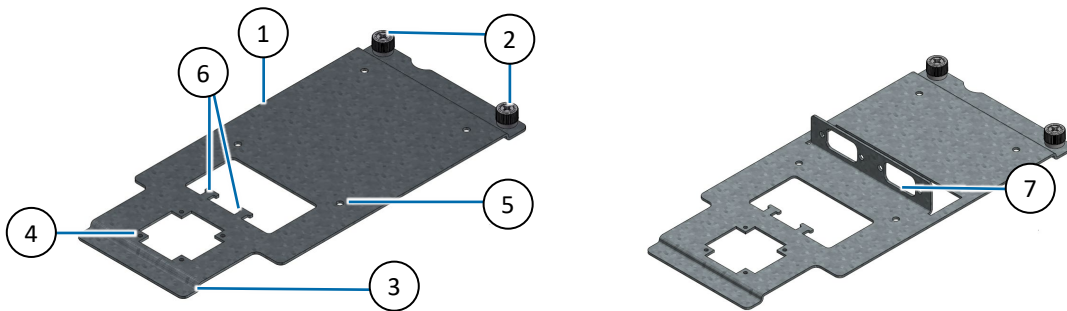

- | | |
|---|--|
| 1. Expansion plate (standard) | 5. 4x Mounting openings (for expansion options) |
| 2. 2x Knurled screws | 6. Cable relief brackets (for expansion options) |
| 3. Hinge for the retaining bracket | 7. Expansion plate (dual COM) |
| 4. 4x mounting openings (reserved for Automotive battery) | |

14.2.1. Replacing the Standard RTC Lithium Battery

The RTC lithium battery will need to be replaced after a period of time. If the expansion plate is included in the hardware configuration, the standard RTC lithium battery is located on the expansion plate; otherwise, the standard RTC Lithium battery is located inside the rear cover.

CAUTION

Danger of Explosion if the lithium battery is incorrectly placed!

- Replace only with the same or equivalent type recommended by the manufacturer
- Dispose of used batteries according to the manufacturer's instructions



An empty RTC lithium battery BIOS does not affect the BIOS settings. However, the system time and date are affected when the RTC lithium battery is empty and must be reconfigured after replacing the battery.



When booting after replacing the RTC lithium battery, the boot time is longer, as the 3.5"-SBC-board performs several reboots before startup.



Do not dispose of lithium batteries in general trash collection. Dispose of the lithium battery according to the local regulations dealing with the disposal of these special materials, (e.g. to the collecting points for disposal of batteries).

Figure 28: Standard RTC Lithium Battery and Battery Extension Cable

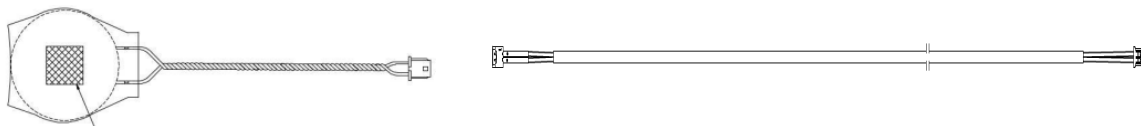

To replace the standard RTC lithium battery, perform the following:

1. Switched off completely using the power button (If provided on the rear cover) and disconnect the external power source using a disconnection device (fuse/circuit breaker) rated in accordance with the wire cross-section and electrical specification of the KPanel S or disconnecting the power cable.
2. Open by loosening the ten captive (M4) screws on the rear cover using an Allen key (size: 3) and carefully moving the front away from the rear cover while taking care not to damage the front's seal, until the front hangs at an angle on the two hinge brackets.
3. Remove the lithium battery by pulling it away from either the rear cover or expansion plate and disconnect the lithium battery cable from the battery extension cable's connector. Connect the new lithium battery to the battery extension cable's header, while ensuring correct polarity and attach the new lithium battery with an adhesive pad to either the rear cover or expansion plate.
4. Close by ensuring the seal on the front is clean and not damaged before moving the front carefully on to the rear cover. Fasten the ten captive (M4) screws by hand and then fasten the ten captive screws crosswise using an Allen key (size 3) while applying a torque of 1.3 NM.

14.2.2. Replacing the Automotive RTC Battery

The automotive RTC Lithium battery located on the removable expansion plate will need to be replaced after a period of time.

⚠ CAUTION

Danger of Explosion if the lithium battery is incorrectly placed!

- Replace only with the same or equivalent type recommended by the manufacturer
- Dispose of used batteries according to the manufacturer's instructions



An empty RTC lithium battery BIOS does not affect the BIOS settings. However, the system time and date are affected when the RTC lithium battery is empty and must be reconfigured after replacing the battery.



When booting after replacing the RTC lithium battery, the boot time is longer, as the 3.5"-SBC-board performs several reboots before startup.



Do not dispose of lithium batteries in general trash collection. Dispose of the lithium battery according to the local regulations dealing with the disposal of these special materials, (e.g. to the collecting points for disposal of batteries).



To replace the automotive battery, the expansion plate must be removed. If an additional expansion option is installed on the expansion plate cables, attached to this option may need to be removed.

Figure 29: Automotive Battery with Battery Extension Cable and Expansion Plate (standard)

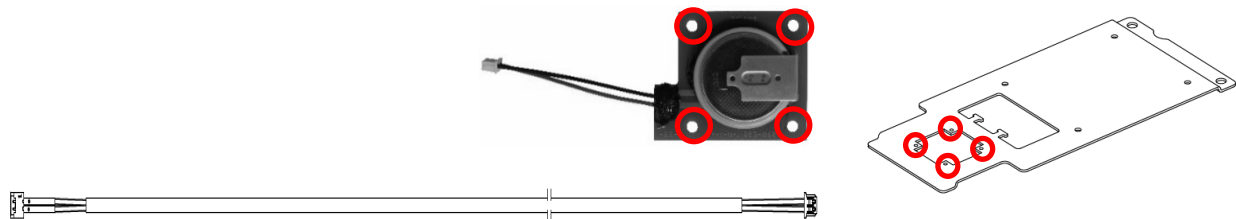

1. Automotive battery module with cable
2. Battery extension cable
3. 4x Mounting openings (automotive battery module)

To replace the automotive battery, perform the following:

1. Switched off completely use the power button (If provided on the rear cover) and disconnect the external power source using a disconnection device (fuse/circuit breaker) rated in accordance with the wire cross-section and electrical specification of the KPanel S or disconnecting the power cable.
2. Open by loosening the ten captive (M4) screws on the rear cover using an Allen key (size: 3) and carefully moving the front away from the rear cover while taking care not to damage the front's seal, until the front hangs at an angle on the two hinge brackets.

3. Release the two knurled screws (Figure 27, pos. 2) on the expansion plate and slide the expansion plate upwards and out of the retaining bracket (Figure 26, pos. 5) and out of the KPanel S
4. Place the expansion plate on an ESD safe surface. Disconnect the automotive battery cable from the battery extension cable's connector and remove the four M2.5 screws that attach the automotive battery to the removable expansion plate. Retain the screws for later use. Connect the new automotive battery to the expansion plate, using the four M2.5 screws removed in step 4 and connect the automotive battery's cable to the battery extension cable's connector while ensuring correct polarity.
5. Slot the expansion plate into the retaining bracket and attach the expansion plate using the two knurled screws.
6. Close by ensuring the seal on the front is clean and not damaged before moving the front carefully on to the rear cover. Fasten the ten captive (M4) screws by hand and then fasten the ten captive screws crosswise using an Allen key (size 3) while applying a torque of 1.3 NM.

14.2.3. Replacing the 2.5" SSD

The 2.5" SSD is located on the expansion plate.

Figure 30: 2.5" SSD and Expansion Plate

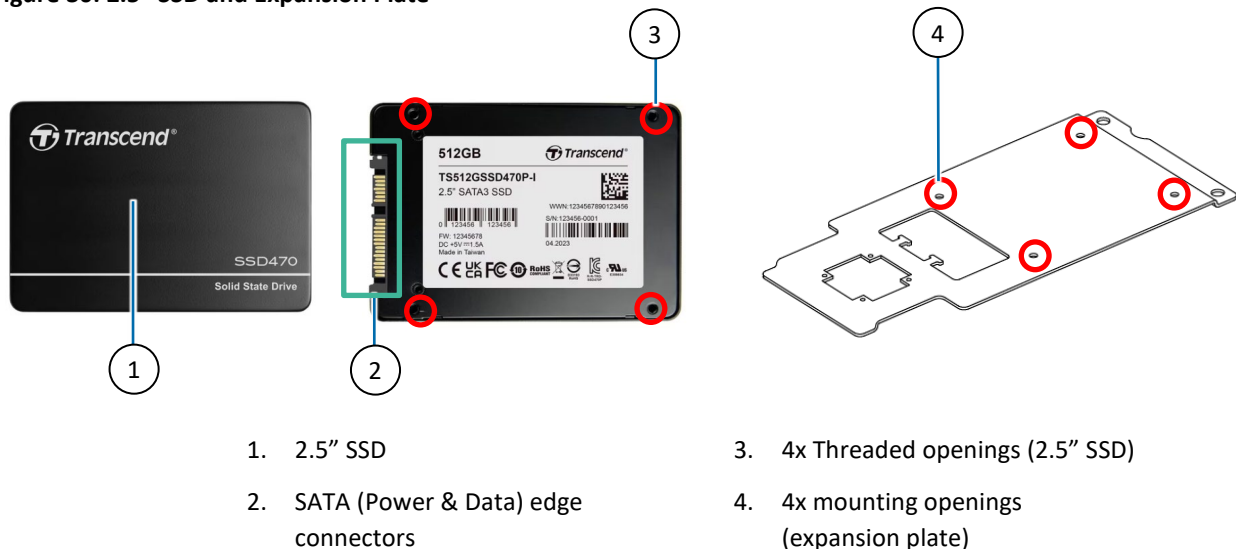

To replace the internal 2.5" SSD on the removable expansion plate, perform the following:

1. Switched off completely use the power button (If provided on the rear cover) and disconnect the external power source using a disconnection device (fuse/circuit breaker) rated in accordance with the wire cross-section and electrical specification of the KPanel S or disconnecting the power cable.
2. Open by loosening the ten captive (M4) screws on the rear cover using an Allen key (size: 3) and carefully moving the front away from the rear cover while taking care not to damage the front's seal, until the front hangs at an angle on the two hinge brackets.
3. Release the two knurled screws (Figure 27, pos. 2) on the expansion plate and slide the expansion plate upwards and out of the retaining bracket (Figure 26, pos. 5).
4. Disconnect the SATA (Power and Data) cables from the 2.5" SDD's edge connectors (Figure 30, pos. 2) and remove the four screws that fasten the underside of the 2.5" SSD (Figure 30, pos. 3) to the expansion plate bracket (Figure 30, pos. 4). Retain the four screws for later use.
5. Position a new 2.5" SDD in the expansion plate brackets and fasten using the four screws removed in step 4. Reconnect the SATA (Power and Data) cables, disconnected in step 4.

6. Slot the expansion plate in the retaining bracket and attach the expansion plate using the two knurled screws.
7. Close by ensuring the seal on the front is clean and not damaged before moving the front carefully on to the rear cover. Fasten the ten captive (M4) screws by hand and then fasten the ten captive screws crosswise using an Allen key (size 3) while applying a torque of 1.3 NM.

14.2.4. Replacing the M.2 SSD on the 2.5" SSD Dual M.2 RAID Module

The 2.5" SSD dual M.2 RAID module with dual M.2 SSDs is located on the expansion plate. Observe the M.2 SSD's manufacturer's instructions and the information and warnings within this chapter.

NOTICE

Do Not Press the Reset Button on the 2.5" SSD Dual M.2 RAID Module

After replacing one of the M.2 SSD(s) on the 2.5" SSD dual M.2 RAID module, do not reset the 2.5" SSD dual M.2 RAID module! When powered on for the first time, the previous RAID configuration will be copied to the new M.2 SSD(s) automatically.

NOTICE

Avoid Data Loss

To avoid loss of data, before removing an M.2 SSD from the 2.5" SSD Dual M.2 RAID module, observe the M.2 SSD drive's manufacturer's instructions and observe the information and warnings within this chapter.

Consider the RAID type and the correct Jumper setting. For more information see Table 30: RAID Jumper Setting.

Table 30: RAID Jumper Setting

Raid Type	J1 Setting	J2 Setting
RAID 0	2	2
RAID 1	1	2

Figure 31: 2.5" SSD Dual M.2 RAID Module and Expansion Plate

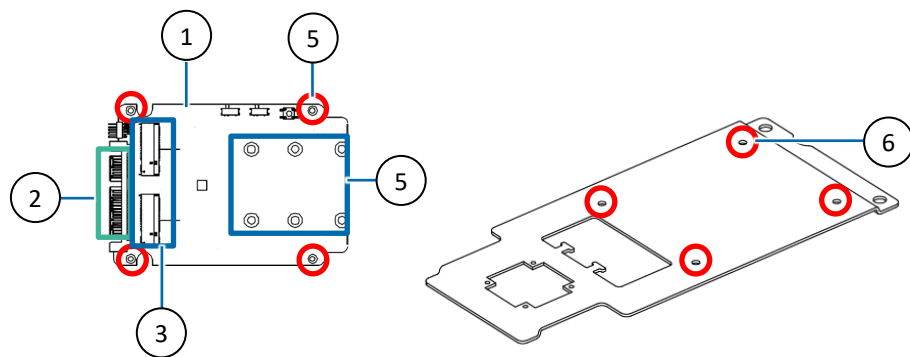

1. 2.5" SSD dual M.2 RAID module
2. SATA (Power & Data) edge connectors
3. 2x M.2 Sockets
4. Screw opening for 2242/2260 and 2280 M.2 SSD modules
5. 4x Mounting openings (2.5" SSD dual M.2 RAID module)
6. 4x Mounting opening (expansion plate)

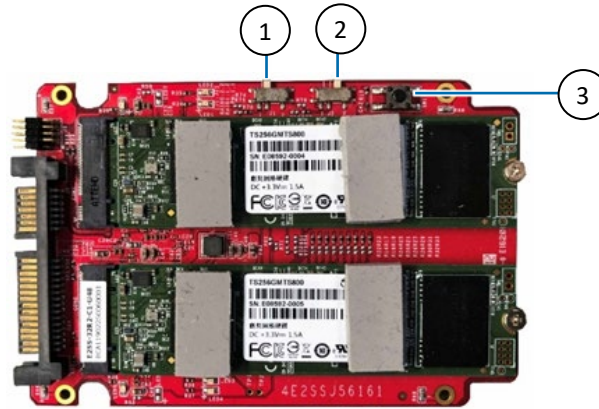
Figure 32: RAID Configuration

1. Jumper 1 (in default position 1)
2. Jumper 2 (In default position 2)
3. Reset Switch



When replacing the M.2 SSD Module

Do not press the reset switch. When powered on for the first time, the previous RAID configuration will be copied to the new M.2 SSD module automatically.

To replace the 2.5" SSD Dual M.2 dual RAID module's M.2 SSD(s), perform the following:

1. Switched off completely use the power button (If provided on the rear cover) and disconnect the external power source using a disconnection device (fuse/circuit breaker) rated in accordance with the wire cross-section and electrical specification of the KPanel S or disconnecting the power cable.
2. Open by loosening the ten captive (M4) screws on the rear cover using an Allen key (size: 3) and carefully moving the front away from the rear cover while taking care not to damage the front's seal, until the front hangs at an angle on the two hinge brackets.
3. Release the two knurled screws (Figure 27, pos. 2) on the expansion plate and slide the expansion plate upwards and out of the retaining bracket (Figure 26, pos. 5). Disconnect the SATA (Power and Data) Cables from the 2.5" SSD Dual M.2 RAID module's edge connectors and remove the expansion plate with 2.5" SSD Dual M.2 RAID module attached.
4. Place the expansion plate with 2.5" SSD Dual M.2 RAID module on an ESD safe surface. Remove the screw attaching the M.2 2280 SSD module to be removed to the 2.5" SSD dual M.2 RAID module. The M.2 2280 SSD module springs up on the free end. Pulling the M.2 2280 SSD module out of the M.2 socket.
5. Insert the new M.2 2280 SSD module at a slight angle gently into the two M.2 socket on the 2.5" SSD dual M.2 RAID module. Press down on the free end to align the screw holes and secure the M.2 SSD module with the screw removed in step 4.
6. Reconnect the SATA (Power and Data) cables removed in step 3 to the 2.5" SSD Dual M.2 RAID module's edge connectors.
7. Set the jumpers J1 and J2 (Figure 32, pos. 1 and 2) to the setting required for the required RAID type, see Table 30: RAID Jumper Setting. The default factory setting is RAID 1.
8. Do not press the reset switch (Figure 32, pos. 3). When powered on for the first time, the previous RAID configuration will be copied to the new M.2 2280 SSD module automatically.

9. Slot the expansion plate in the retaining bracket and attach the expansion plate using the two knurled screws.
10. Close by ensuring the seal on the front is clean and not damaged before moving the front carefully on to the rear cover. Fasten the ten captive (M4) screws by hand and then fasten the ten captive screws crosswise using an Allen key (size 3) while applying a torque of 1.3 NM.

15/ Technical Support

For technical support contact our Support Department:

- › E-mail: support@kontron.com
- › Phone: +49-821-4086-888

Make sure you have the following information available when you call:

- › Product ID Number (PN),
- › Serial Number (SN)



The serial number can be found on the Type Label, located on the product's rear cover.

Be ready to explain the nature of your problem to the service technician.

15.1. Returning Defective Merchandise

All equipment returned to Kontron must have a Return of Material Authorization (RMA) number assigned exclusively by Kontron. Kontron cannot be held responsible for any loss or damage caused to the equipment received without an RMA number. The buyer accepts responsibility for all freight charges for the return of goods to Kontron's designated facility. Kontron will pay the return freight charges back to the buyer's location in the event that the equipment is repaired or replaced within the stipulated warranty period. Follow these steps before returning any product to Kontron.

1. Visit the RMA Information website: <https://www.kontron.com/en/support/rma-information>
2. Download the RMA Request sheet for Kontron Europe GmbH and fill out the form. Take care to include a short detailed description of the observed problem or failure and to include the product identification Information (Name of product, Product number and Serial number). If a delivery includes more than one product, fill out the above information in the RMA Request form for each product. Send the completed RMA-Request form to the fax or email address given below at Kontron Europe GmbH. Kontron will provide an RMA-Number.
3. Kontron Europe GmbH
RMA Support
Phone: +49 (0) 821 4086-0
Fax: +49 (0) 821 4086 111
Email: service@kontron.com
4. The goods for repair must be packed properly for shipping, considering shock and ESD protection.



Goods returned to Kontron Europe GmbH in non-proper packaging will be considered as customer caused faults and cannot be accepted as warranty repairs

5. Include the RMA-Number with the shipping paperwork and send the product to the delivery address provided in the RMA form or received from Kontron RMA Support.

16/ Storage and Transportation

16.1. Storage

If the product is not in use for an extended period time, disconnect the power plug from the power supply. If it is necessary to store the product then re-pack the product as originally delivered to avoid damage. The storage facility must meet the product's environmental storage requirements as stated within this user guide. Kontron recommends keeping the original packaging material for future storage or warranty shipments.

16.2. Transportation

To ship the product, use the original packaging, designed to withstand impact and adequately protect the product. When packing or unpacking products, always take shock and ESD protection into consideration and use an ESD safe working area.

17/ Warranty

Due to their limited service-life, parts that by their nature are subject to a particularly high degree of wear (wearing parts) are excluded from the warranty beyond that provided by law. This applies to the lithium battery, for example.



If there is a protection label on your product, then the warranty is lost if the product is opened.

18/ Disposal

18.1. Disposal

Disposal of the product in accordance with country, state, or local regulations and requirements as part of your disposition and decommissioning policies or recycle the product or parts of the product for re-use after performing data sanitation to erase the data stored on the product.

When disposing of the product

- › Remove any product labels from the product that could indicate ownership and provide a clue to the type of data stored on the memory device.
- › Consider your company's environmental requirements and the requirements of Waste Electrical and Electronic Equipment (WEEE) directive.
- › Before removing the product from the operating environment, consider if there is data stored on the product that can only be removed securely when the product is connected to power.
- › Use data sanitation guidelines to ensure that data sensitive to your business and/or confidential or proprietary data and software is removed from the product using a data sanitation method that stops the data from being retrieved or reconstructed after deletion or by destruction of the part, see Chapter 18.3: Data Sanitation.

18.2. WEEE Compliance

The Waste Electrical and Electronic Equipment (WEEE) Directive aims to:

- › Reduce waste arising from electrical and electronic equipment (EEE)
- › Make producers of EEE responsible for the environmental impact of their products, especially when the product becomes waste
- › Encourage separate collection and subsequent treatment, reuse, recovery, recycling and sound environmental disposal of EEE
- › Improve the environmental performance of all those involved during the lifecycle of EEE



Environmental protection is a high priority with Kontron.
Kontron follows the WEEE directive
You are encouraged to return our products for proper disposal.

18.3. Data Sanitation

Data sanitization is the process of permanently erasing or destroying sensitive data on the product's memory devices to prevent unauthorized access to data sensitive to your business and/or confidential/proprietary data stored on the memory devices.

When designing a product, the user must plan for data sanitization and designing in memory devices that are easier to sanitize, memory devices from manufactures that provide an effective data erasure tool or memory devices from manufactures that support a return to factory default command.

When performing data sanitation, the user must consider if the product's memory devices contain sensitive data and develop a data sanitation plan to erase all sensitive data in accordance with country, state, or local data sanitization regulations and requirements or as part of your disposal and decommissioning policies.



Data Sanitation

Users are responsible for erasing memory devices in accordance with country, state, or local data sanitization regulations and requirements or as part of your disposition and decommissioning policies.

Kontron recommends performing data sanitation when reusing the product in a different user environment, sending the product in for repair and disposing or decommissioning the product.

General guidelines when performing data sanitation on the product:

- › Before powering down, consider if power is required to perform data sanitation on the product's memory devices. When disconnected from the power source, dismantle all removable memory devices from the product.
- › For memory devices containing data sensitive to your business and/or confidential/proprietary data, use the data sanitation method most suitable for memory device type to be erased. Consider the memory device's volatility. Volatile memory devices only store data temporarily and their data can be erased easily by disconnecting the power/removing the battery for approximately 24 hours. However, non-volatile memory devices store data permanently and retain information when disconnected to power and must be actively erased using an accredited third-party software tool or manufacture's data erasure tool or return to factor default command or destructed.
 - › Use an accredited third-party software tool on memory devices. The accredited third-party software tool must provide an audit trail, be capable of performing a complete data clean including areas such as hidden data and bad blocks not accessed by general service-based utilities.
 - › Use physical destruction methods on memory devices that cannot be securely software erased. The aim of the destruction is to break the silicon die within the chips package into two or more parts to prevent reading data from the die. Fragments should be no longer than 6 mm. If this service is performed by a third party obtain destruction certificates for confirmation.
 - › Use the manufacture's data erasure tool for sanitization or return to factor default command (if provided by the manufacturer). The manufactures tools and commands have been designed to fulfil the data sanitation requirement of the manufacture's specific memory device(s).
- › Verify that all sensitive data has been effectively sanitized.



Dismantle Removable Memory

Dismantle all removable memory devices from the product. For reuse, erase the data using:

- › An accredited third-party software tool.
- › Manufacture's data erasure tool' or 'return to factor default command'. (if provided)

If not reused physically destruct the memory device according to data sanitation guidelines.



Erase Data

To ensure that forensic tools cannot be used to recover data:

- › Use an accredited third-party software tool, with an audit trail, capable of performing a complete data clean including areas such as hidden data and bad blocks not accessed by general service- based utilities.
- › Use the manufacture's data erasure tool or return to factor default command designed to fulfil the data sanitation requirement of the manufacture's specific memory device(s).

Physical Destruction



When physically destructing the memory:

- Follow proper safety protocols.
- Break the chip packaged silicon die into two or more parts, fragments <= 6 mm.
- Check both sides as memory devices may be positioned on the rear side.
- Use a third-party destruction company providing destruction certificates for confirmation.

18.4. Statement of Memory Volatility

The KPanel S-RPL statement of memory volatility provides the user with a detailed list of the product's memory devices and their volatility, to enable the user to develop a suitable data sanitization plan.

Note that not all listed memory devices may be part of your delivered product. Some memory devices may be configuration options. Users are responsible for considering the memory devices installed on the product and must take appropriate action to clear the memory if required.

Third-party devices such as M.2 modules installed within the product may include memory devices and should be removed by the user before disposing of the product. It is the responsibility of the user to observe that the third-party devices are removed according to the manufacturer's instructions.

Options available on user request are not considered within the statement of memory volatility.



In some cases, special tools and/or software are necessary to access the memory



The Statement of Memory Volatility is a list of the known possible memory devices and due to configuration options may differ from your delivered product.

Table 31: Statement of Memory Volatility for KPanel S-RPL

Memory Type	Ref. # / Loc.	Memory Size ^[2]	Volatility	Retain Data when Power Off	Alterable in Field ^[1]	Battery Backed Up	Data Type	Write Protected	Emergency Erase	Process to Clear
DDR										
DDR5 SO-DIMM	SBC Board	Up to 48 GB	Volatile	No	Yes	No	User Data	No	No	NA
DDR5 SO-DIMM	DIMM slot	Up to 48 GB	Volatile	No	Yes	No	User Data	No	No	NA
Embedded Controller (EC)										
Embedded Controller MEC1521	SBC Board	Code Storage: 480 KB (Code + Data) Data RAM: 32 KB	Non-volatile (Code storage) Volatile (RAM)	Yes	Yes	No	Embedded controller config.	Yes	No	Perform EC FW update

Memory Type	Ref. # / Loc.	Memory Size ^[2]	Volatility	Retain Data when Power Off	Alterable in Field ^[1]	Battery Backed Up	Data Type	Write Protected	Emergency Erase	Process to Clear
CMOS-FLASH SPI MX25V16 35FM2I	SBC Board	16 Mbit	Non-volatile	Yes	Yes	No	EFI Boot	Yes	Yes	Perform BIOS recovery
LAN										
FLASH SPI W25Q16J VSSIQ	SBC Board	16 Mbit	Non-volatile	Yes	Yes	No	EFI Boot	Yes (SW)	No	Perform BIOS recovery
BIOS										
FLASH SPI W25Q256J VEIQ	SBC Board	256 Mbit	Non-volatile	Yes	Yes	No	EFI Boot	Yes (SW)	No	Perform BIOS recovery
EEPROM										
EEPROM AT24C32E- SSHM-T	SBC Board	32 Kbit	Non-volatile	Yes	Yes	No	Module ID Data	Yes	No	NA
LVDS										
EEPROM Chrontel CH9904	SBC Board	64 Kbit	Non-volatile	Yes	Yes	No	Module ID Data	Yes	No	NA
VCORE										
MP2964R	SBC Board	8 Kbit	Non-volatile	Yes	No	No	VR Config.	No	No	NA
TPM										
SLB 9672XU2.0	SBC Board	51 KByte	Non-volatile	Yes	Yes	No	User Data	Yes	No	Perform clear item under OS
CF Type I/II Memory Card										
CF memory card (User provided) [3]	Expan. plate	User defined	Non-volatile	Yes	Yes	No	User Data	Yes	No	Remove the CF memory card from the CF Slot.
2.5" SSD Drive										
2.5" SSD Drive ^[3]	Expan. plate	Up to 1 TByte	Non-volatile	Yes	Yes	No	User data	No	No	Remove or use 3rd party overwrite tool
M.2 SSD Drive										
M.2 2280 SSD ^[3]	Expan. plate, RAID module	Up to 4 TByte	Non-volatile	Yes	Yes	No	User data	No	No	Remove or use 3rd party overwrite tool

^[1] In some cases special tools and/or software are necessary to access the memory.

^[2] Memory size may vary, as over time devices reach EOL or newer higher-density memory devices are introduced.

^[3] This memory type is an option and may not be included in your configuration.

19/ Cyber Security

Cyber security is an important aspect to consider when installing, operating, maintaining and disposing of the product. This chapter provides cyber security guidelines for the user.



Security White Paper

For cyber security guidelines to protect your Kontron product from potential cyber security threats, refer to Kontron's [Security White paper](#).



Security Measures

Kontron is not aware of the final target end user environment in which the product operates. It is not possible for Kontron to provide precise instructions for your cyber security measures. Kontron strives to provide hints for considerations for your threat analysis and to point out particular security mechanisms implemented in Kontron products.

19.1. Security Defense Strategy

When developing your security defense strategy consider implementing the following guidelines to help you effectively secure the product:

- › Policies and procedures developed in association with the product's/end environment's security.
- › Instructions and recommendations for periodic security maintenance activities and reporting product security incidents.
- › Security network controls/setting such as firewall rules.
- › Third party software tools that further protect the product.
- › Authentication to access the product, limit user privileges and managing user accounts.
- › Data encryption.
- › Reduced number of potential security entry points.
- › BIOS/OS and security updates that do not compromise the product's operation or defense in depth strategy.
- › User accounts with length and complexity requirements.
- › Supplied default passwords are changed.
- › Limited network access (IP address range).
- › Installation of anti-virus and malware software.
- › Network access requirements such as VPN.

Appendix: List of Acronyms

AC	Alternating Current
BIOS	Basic Input Output System
BSP	Board Support Package
CAN	Controller Area Network
CE	Conformité Européenne
COM	Communication port
DC	Direct Current
DP	DisplayPort
EEE	Electrical and Electronic Equipment
EMC	Electro Magnetic compatibility
ESD	Electro Static Discharge
FCC	Federal Communications Commission
GbE	Giga Bit Ethernet
HD	High Definition
HDMI	High Definition Multimedia Interface
IOT	Internet of Things
LAN	Local Area Network
LED	Light Emitting Diode
LPS	Limited Power Source
LTE	Long-Term Evolution
MDI	Media Dependent Interface
MTBF	Mean Time Before Failure
PS	Power Source
PSU	Power Supply Unit
RMA	Return of Material Authorization
RoHS	Restriction of Hazardous Substances
RTC	Real Time Clock
SD card	Secure Digital Card
SIM	Subscriber Identity Module
SSD	Solid State Drive
S.M.A.R.T	Self-Monitoring, Analysis and Reporting Technology
SVGA	Super Video Graphics Array
TFT	Thin-Film Transistors
TNV	Telecommunications Network Voltage
TPM	Trusted Platform Module
UEFI	Unified Extensible Firmware Interface
UK CA	UK Conformity Assessed
UL	Underwriters Laboratories

USB	Universal Serial Bus
UV	Ultra Violet
VESA	Video Electronics Standards Association
VGA	Video Graphics Array
WEEE	Waste Electrical and Electronic Equipment
WXGA	Wide Extended Graphics Array
XGA	Extended Graphics Array



About Kontron

Kontron is a global leader in IoT/Embedded Computing Technology (ECT) and offers individual solutions in the areas of Internet of Things (IoT) and Industry 4.0 through a combined portfolio of hardware, software and services. With its standard and customized products based on highly reliable state-of-the-art technologies, Kontron provides secure and innovative applications for a wide variety of industries. As a result, customers benefit from accelerated time-to-market, lower total cost of ownership, extended product lifecycles and the best fully integrated applications.

For more information, please visit: www.kontron.com

Global Headquarters

Kontron Europe GmbH

Gutenbergstraße 2
85737 Ismaning, Germany
Tel.: +49 8214 4086-0
info@kontron.com

www.kontron.de

