

User Manual

for the Motherboards:

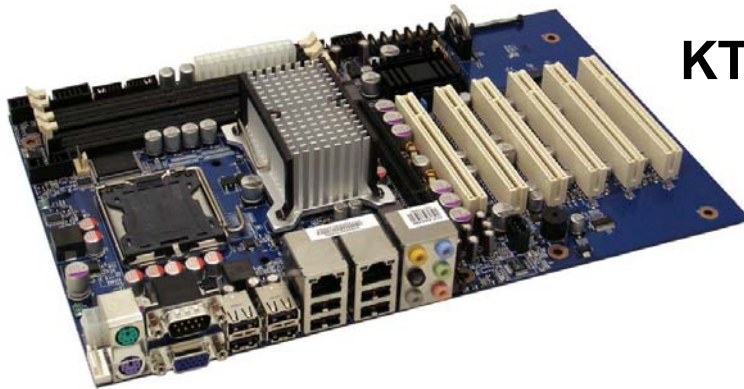

KT965/Flex



KT965/ATXP

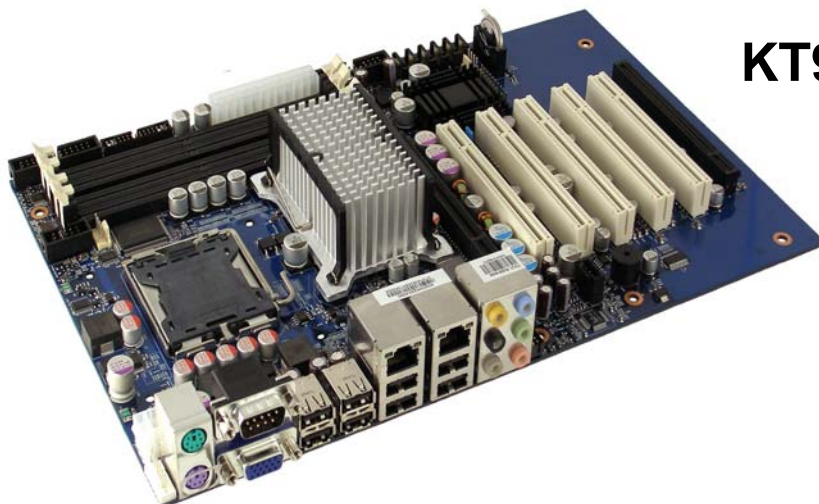

KT965/ATXE

Document revision history.

Revision	Date	By	Comment
S	April 15 th 2010	MLA	Updated Voltage Monitor read out. Updated warning info to installation guide. APM information corrected. Minor corrections.
R	Oct. 19 th 2009	MLA	BIOS part features added, minor corrections and layout changed.
Q	Oct. 13 th 2009	MLA	Corrected BIOS SpeedStep info. Added "mounting the board to chassis". Minor layout changes.
P	June 9 th 2009	MLA	TPM support added. Battery alternative added. CPU E4700 added. Correction to LAN connector pinning. Added BIOS setting: PCI Slot-2 IRQ Preference.
O	Dec. 10 th 2008	MLA	Added note on XP for ACPI USB Wakeup. Added info to USB Function in BIOS description. PCI Riser info corrected. MTBF values added. CPU list updated. Minor layout changes.
N	May 30 th 2008	MLA	Added info on BIOS version when using XP SP3. Battery type updated.
M	April 22 nd 2008	MLA	Added Windows Vista support. 3.3V tolerance increased. CPU list updated.
L	April 2 nd 2008	MLA	Text "WinCE support" removed. In BIOS description: Deleted remaining Floppy controller info and corrected IO Controller version to 627DHG.
K	Mar. 6 th 2008	MLA	Battery load information added. For BIOS part: Added APM settings, changed SpeedStep setting, added note on ETH1/2 WOL, change name of Vanderpool to Virtualization, ACPI settings modified and IDE description changed. Other minor changed.
J	Jan. 2 nd 2008	MLA	"LPT" replaced with "Printer". BIOS function "Long Splash" added. Minor corrections to "Onboard connectors". 4K7 added to FAN Tables. Added CPU Q6600 and Q6700.
0 - I	Oct. 17 th , 2007	MLA	<i>(Text removed in revision O of this document)</i>

Copyright Notice:

Copyright © 2007, KONTRON Technology A/S, ALL RIGHTS RESERVED.

No part of this document may be reproduced or transmitted in any form or by any means, electronically or mechanically, for any purpose, without the express written permission of KONTRON Technology A/S.

Trademark Acknowledgement:

Brand and product names are trademarks or registered trademarks of their respective owners.

Disclaimer:

KONTRON Technology A/S reserves the right to make changes, without notice, to any product, including circuits and/or software described or contained in this manual in order to improve design and/or performance.

Specifications listed in this manual are subject to change without notice. KONTRON Technology assumes no responsibility or liability for the use of the described product(s), conveys no license or title under any patent, copyright, or mask work rights to these products, and makes no representations or warranties that these products are free from patent, copyright, or mask work right infringement, unless otherwise specified. Applications that are described in this manual are for illustration purposes only. KONTRON Technology A/S makes no representation or warranty that such application will be suitable for the specified use without further testing or modification.

Life Support Policy

KONTRON Technology's PRODUCTS ARE NOT FOR USE AS CRITICAL COMPONENTS IN LIFE SUPPORT DEVICES OR SYSTEMS WITHOUT EXPRESS WRITTEN APPROVAL OF THE GENERAL MANAGER OF KONTRON Technology A/S.

As used herein:

1. Life support devices or systems are devices or systems which, (a) are intended for surgical implant into body, or (b) support or sustain life and whose failure to perform, when properly used in accordance with instructions for use provided in the labeling, can be reasonably expected to result in significant injury to the user.
2. A critical component is any component of a life support device or system whose failure to perform can be reasonably expected to cause the failure of the life support device or system, or to affect its safety or effectiveness.

KONTRON Technology Technical Support and Services

If you have questions about installing or using your KONTRON Technology Product, check this User's Manual first – you will find answers to most questions here. To obtain support, please contact your local Distributor or Field Application Engineer (FAE).

Before Contacting Support: Please be prepared to provide as much information as possible:

- CPU Board
 1. Type.
 2. Part-number.
 3. Serial Number.
- Configuration
 1. CPU Type, Clock speed.
 2. DRAM Type and Size.
 3. BIOS Revision (Find the Version Info in the BIOS Setup).
 4. BIOS Settings different than *Default* Settings (Refer to the BIOS Setup Section).
- System
 1. O/S Make and Version.
 2. Driver Version numbers (Graphics, Network, and Audio).
 3. Attached Hardware: Harddisks, CD-rom, LCD Panels etc.

Table of contents:

1.	INTRODUCTION	7
2.	INSTALLATION PROCEDURE	8
2.1	Installing the board	8
2.2	Requirement according to EN60950	10
3.	SYSTEM SPECIFICATION	11
3.1	Component main data	11
3.2	System overview	14
3.3	Processor support table	15
3.4	System Memory support	16
3.4.1	Memory Operating Frequencies	16
3.4.2	Memory Configurations.....	16
3.5	KT965 Graphics Subsystem	18
3.5.1	Intel GMA 3000 Graphics Controller.....	18
3.5.2	Dynamic Video Memory Technology (DVMT)	18
3.5.3	Advanced Digital Display (ADD2) card Support.....	19
3.6	KT965 Power State Map	20
3.7	Power Consumption	22
3.8	KT965 Clock Distribution	24
4.	CONNECTOR DEFINITIONS	25
4.1	Connector layout	26
4.1.1	KT965/Flex.....	26
4.1.2	KT965/ATXP	27
4.1.3	KT965/ATXE	28
4.2	Power Connector (ATXPWR)	29
4.3	Keyboard and PS/2 mouse connectors	30
4.3.1	Stacked MINI-DIN keyboard and mouse Connector (MSE & KBD).....	30
4.3.2	Keyboard and mouse pin-row Connector (KBDMSE)	30
4.4	Display Connectors	31
4.4.1	CRT Connector (CRT).....	31
4.5	PCI-Express Connectors	32
4.5.1	PCI-Express x16/ SDVO connector.....	32
4.5.2	PCI-Express x4 in a x16 connector	33
4.5.3	miniPCI-Express connector	35
4.6	Serial ATA harddisk interface	36
4.6.1	SATA Hard Disk Connector (SATA0, SATA1, SATA2, SATA3, SATA4, SATA5).....	36
4.7	Printer Port Connector (PRINTER)	37
4.8	Serial Ports	38

4.8.1	Com1 (Port1) DB9 Connector.	38
4.8.2	Com2 Pin Header Connector.	38
4.9	Ethernet connectors.	39
4.9.1	Ethernet connector 1 (ETHER1).....	39
4.9.2	Ethernet connector 2 (ETHER2).....	40
4.10	USB Connector (USB).....	41
4.10.1	USB Connector 0/2 (USB0/2).....	41
4.10.2	USB Connector 4/5 (USB4/5).....	42
4.10.3	USB Connector 6/7 (USB6/7).....	42
4.10.4	USB Connector 8/9 (USB8/9).....	43
4.11	Audio Connector	44
4.11.1	Audio Line-in, Line-out and Microphone.....	44
4.11.2	CD-ROM Audio input (CDROM).....	45
4.11.3	AUDIO Header (AUDIO_HEAD).....	46
4.12	Fan connectors , FAN_CPU and FAN_SYS.	47
4.13	The Clear CMOS Jumper, Clr-CMOS.	48
4.14	TPM connector (unsupported).....	49
4.15	SPI connector (unsupported).....	49
4.16	Front Panel connector (FRONTPNL).....	50
4.17	Feature Connector (FEATURE).....	51
4.18	PCI Slot Connector.....	52
4.18.1	Signal Description –PCI Slot Connector.....	53
4.18.2	KT965 PCI IRQ & INT routing.....	55
5.	ONBOARD CONNECTORS	56
6.	SYSTEM RESSOURCES.....	57
6.1	Memory map.....	57
6.2	PCI devices	58
6.3	Interrupt Usage	59
6.4	I/O Map	60
6.5	DMA Channel Usage.....	61
7.	OVERVIEW OF BIOS FEATURES.....	62
7.1	System Management BIOS (SMBIOS / DMI).....	62
7.2	Legacy USB Support	62
8.	BIOS CONFIGURATION / SETUP	63
8.1	Introduction	63
8.2	Main Menu.....	63

8.3	Advanced Menu.....	64
8.3.1	Advanced settings – CPU Configuration	65
8.3.2	Advanced settings – IDE Configuration.....	66
8.3.3	Advanced settings – LAN Configuration.....	68
8.3.4	Advanced settings – Super IO Configuration	69
8.3.5	Advanced settings – Hardware Health Configuration	70
8.3.6	Advanced settings – Voltage Monitor	71
8.3.7	Advanced settings – ACPI Configuration	72
8.3.8	Advanced settings – APM Configuration	73
8.3.9	PCI Express Configuration	74
8.3.10	Advanced settings – Remote Access Configuration	75
8.3.11	Advanced settings – TCG/TPM support	76
8.3.12	Advanced settings – USB Configuration	77
8.3.13	Advanced settings – USB Mass Storage Device Configuration	78
8.4	PCIPnP Menu.....	79
8.5	Boot Menu.....	80
8.5.1	Boot – Boot Settings Configuration	81
8.5.2	Boot – Boot Device Priority	82
8.6	Security Menu.....	83
8.7	Chipset Menu.....	84
8.7.1	Advanced Chipset Settings – North Bridge Chipset Configuration	85
8.7.2	Advanced Chipset Settings – Video Function Configuration.....	86
8.7.3	Advanced Chipset Settings – SouthBridge Configuration	87
8.8	Exit Menu	88
8.9	AMI BIOS Beep Codes.....	89
9.	OS SETUP.....	90
10.	WARRANTY.....	90

1. Introduction

This manual describes the KT965/Flex, KT965/ATXP and KT965/ATXE boards made by KONTRON Technology A/S. The boards will also be denoted KT965 family if no differentiation is required.

All boards are to be used with the Intel® Core™2 Quad, Intel® Core™2 Duo, Intel® Pentium® 4 and the Intel® Celeron® D Processors.

These belong to the Intel Conroe and Cedar Mill processor families.

Use of this manual implies a basic knowledge of PC-AT hard- and software. This manual is focused on describing the KT965 Board's special features and is not intended to be a standard PC-AT textbook.

New users are recommended to study the short installation procedure stated in chapter 3 before switching on the power.

All configuration and setup of the CPU board is either done automatically or by the user in the CMOS setup menus. Except for the CMOS Clear jumper, no jumper configuration is required.

2. Installation procedure

2.1 Installing the board

To get the board running, follow these steps. In some cases the board shipped from KONTRON Technology has CPU, DDR DRAM and Cooler mounted. In this case Step 2-4 can be skipped.

1. Turn off the power supply



Warning: Turn off PSU (Power Supply Unit) completely (no mains power connected to the PSU) or leave the Power Connectors unconnected while configuring the board. Otherwise components (RAM, LAN cards etc.) might get damaged. Do not use PSU's without 3.3V monitoring watchdog, which is standard feature in ATX PSU's. Running the board without 3.3V connected will damage the board after a few minutes.

2. Insert the DDR2 DIMM 240pin DRAM module(s)

Be careful to push it in the slot(s) before locking the tabs. For a list of approved DDR2 DIMM modules contact your Distributor or FAE.

DDR2-800 DIMM 240pin DRAM modules (PC6400) are supported.

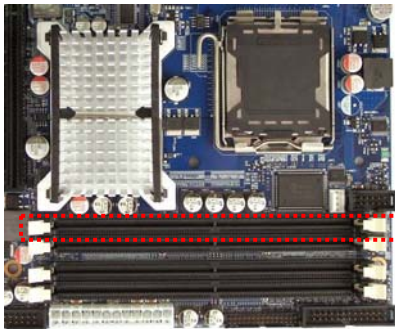

NOTE: Regardless of the Memory configuration used, DDR2 SLOT 1 (J1) must always be populated.

3. Install the processor

The CPU is keyed and will only mount in the CPU socket in one way. Use the handle to open/ close the CPU socket. The Intel® Core™2 Quad, Intel® Core™2 Duo, Intel® Pentium® 4 and the Intel® Celeron® D Processors in LGA775 package are supported, refer to supported processor overview for details.

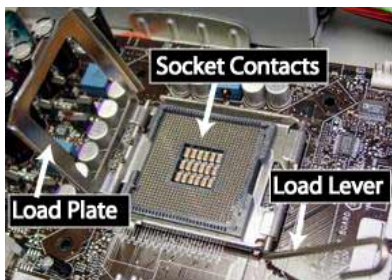

Do NOT touch socket contacts

Opening the socket:

Note: Apply pressure to the corner with right hand thumb while opening/closing the load lever, otherwise lever can bounce back like a “mouse trap” and WILL cause bent contacts (when loaded)

1. Disengage Load Lever by depressing down and out on the hook to clear retention tab
2. Rotate Load Lever to fully open position at approximately 135°
3. Rotate Load Plate to fully open position at approximately 100°

Remove Socket Protective Cover

With left hand index finger and thumb to support the load plate edge, engage protective cover finger tab with right hand thumb and peel the cover from LGA775 Socket while pressing on center of protective cover to assist in removal.

Set protective cover aside. Always put cover back on if the processor is removed from the socket.

IMPORTANT:

For return goods (RMA): warranty is void if board is returned without Protective cover.

Visually inspect protective cover for damage

If damage observed, replace the cover.

NOTE: After cover removal, make sure socket load plate and contacts are free of foreign material. Debris may be removed with compressed air.

NOTE: Removing protective cover after CPU insertion will compromise the ability to visually inspect socket.

Processor Installation

Locate Connection 1 indicator and the two orientation key notches.

Grasp the processor with thumb and index finger. (Grasp the edges without the orientation notches.) The socket has cutouts for your fingers to fit into.

Carefully place the package into the socket body using a purely vertical motion. (Tilting the processor into place or shifting it into place on the socket can damage the sensitive socket contacts.)

CAUTION: Recommend not to use a Vacuum Pen for installation.

Verify that package is within the socket body and properly mated to the orientation keys

Close the socket by:

- A. Close the Load Plate
- B. While pressing down lightly on Load Plate, engage the Load Lever.
- C. Secure Load Lever with Load Plate tab under retention tab of Load Lever

4. Cooler Installation

Use heat paste or adhesive pads between CPU and cooler and connect the Fan electrically to the FAN_CPU connector.

5. Connecting Interfaces

Insert all external cables for hard disk, keyboard etc. A CRT monitor must be connected in order to change CMOS settings to flat panel support. When using bootable SATA disk, then connect to SATA0 or SATA2 or select in BIOS "ATA/IDE Configuration" = Enhanced.

6. Connect Power supply

Connect power supply to the board by the ATX/ BTPWR and 4-pin ATX connectors. For board to operate connection of both the ATX/BTX and 4-pin ATX (12V) connectors are required.

7. Turn on the power on the ATX/ BTX power supply**8. Power Button**

The PWRBTN_IN must be toggled to start the Power supply; this is done by shorting pins 16 (PWRBTN_IN) and pin 18 (GND) on the FRONTPNL connector (see Connector description). A "normally open" switch can be connected via the FRONTPNL connector.

9. BIOS Setup

Enter the BIOS setup by pressing the key during boot up. Refer to the "BIOS Configuration / Setup" section of this manual for details on BIOS setup.

Enter Advanced Menu / CPU Configuration / Intel SpeedStep Tech. and set this option to "Maximum Performance".

Note: To clear all CMOS settings, including Password protection, move the Clr-CMOS jumper (with or without power) for approximately 1 minute. Alternatively turn off power and remove the battery for 1 minute, but be careful to orientate the battery correctly when reinserted.

10. Mounting the board to chassis

Warning: When mounting the board to chassis etc. please notice that the board contains components on both sides of the PCB which can easily be damaged if board is handled without reasonable care. A damaged component can result in malfunction or no function at all.

When fixing the Motherboard on a chassis it is recommended using screws with integrated washer and having diameter of ~7mm.

Note: Do not use washers with teeth, as they can damage the PCB mounting hole and may cause short circuits.

2.2 Requirement according to EN60950

Users of KT965 boards should take care when designing chassis interface connectors in order to fulfill the EN60950 standard:

When an interface/connector has a VCC (or other power) pin, which is directly connected to a power plane like the VCC plane:

To protect the external power lines of peripheral devices the customer has to take care about:

- That the wires have the right diameter to withstand the maximum available power.
- That the enclosure of the peripheral device fulfils the fire protecting requirements of IEC/EN 60950.

Lithium Battery precautions:

<p style="text-align: center;">CAUTION!</p> <p>Danger of explosion if battery is incorrectly replaced.</p> <p>Replace only with same or equivalent type recommended by manufacturer. Dispose of used batteries according to the manufacturer's instructions.</p>	<p style="text-align: center;">VORSICHT!</p> <p>Explosionsgefahr bei unsachgemäßem Austausch der Batterie.</p> <p>Ersatz nur durch den selben oder einen vom Hersteller empfohlenen gleichwertigen Typ. Entsorgung gebrauchter Batterien nach Angaben des Herstellers.</p>
<p style="text-align: center;">ADVARSEL!</p> <p>Lithiumbatteri – Eksplosionsfare ved fejlagtig håndtering. Udskiftning må kun ske med batteri af samme fabrikat og type. Levér det brugte batteri tilbage til leverandøren.</p>	<p style="text-align: center;">ADVARSEL</p> <p>Eksplosjonsfare ved feilaktig skifte av batteri. Benytt samme batteritype eller en tilsvarende type anbefalt av apparatfabrikanten. Brukte batterier kasseres i henhold til fabrikantens instruksjoner.</p>
<p style="text-align: center;">VARNING</p> <p>Explosionsfara vid felaktigt batteribyte. Använd samma batterityp eller en ekvivalent typ som rekommenderas av apparattillverkaren. Kassera använt batteri enligt fabrikantens instruktion.</p>	<p style="text-align: center;">VAROITUS</p> <p>Paristo voi räjähtää, jos se on virheellisesti asennettu. Vaihda paristo ainoastaan laltevalmistajan suosittalemaan tyyppiin. Hävitä käytetty paristo valmistajan ohjeiden mukaisesti.</p>

3. System specification

3.1 Component main data

The table below summarises the features of the KT965/Flex, KT965/ATXP and KT965/ATXE embedded motherboards.

Form factor	KT965/Flex: Flex-ATX (190,50millimeters by 228,60millimeters) KT965/ATXP: ATX (190,50millimeters by 304,00millimeters) KT965/ATXE: ATX (190,50millimeters by 304,00millimeters)
Processor	<ul style="list-style-type: none"> Support for Intel® Core™2 Quad, Intel® Core™2 Duo, Intel® Pentium® 4 and the Intel® Celeron® D in LGA775 package with up to 1066MHz system bus and 1/2/4/8MB internal cache. Support for Conroe (65 nanometer) and Cedar Mill (65 nanometer) family processors.
Memory	<ul style="list-style-type: none"> 4 pcs DDR2 DIMM 240pin DRAM sockets. Support for DDR 533/667/800MHz (PC2-4200/PC2-5300/PC2-6400) Support system memory from 512MB and up to 4GB (*) (32 bit OS) / 8GB (64 bit OS). (*) Only approx. 3GB displayed in System Properties. (Shared Video Memory is withdrawn). ECC not supported
Chipset	Intel Q965 Chipset consisting of: <ul style="list-style-type: none"> Intel® 82Q965 Graphics Memory Controller Hub (GMCH) Intel® ICH8DO I/O Controller Hub (ICH8DO)
Video	<ul style="list-style-type: none"> Intel® GMA 3000 graphics engine Dynamic Video Memory Technology (DVMT 4.0), allowing up to 256MB dynamically allocated Video Memory (System memory is allocated when it is needed). Analog Display Support CRT, 400-MHz, 24 bit integrated RAMDAC with support for analogue monitors up to 2048x1536 at 75 Hz Single or dual channel 24bit LVDS panel support (OpenLDI/ SPWG) up to UXGA (1600x1200) panel resolution supported by using ADD2 / SDVO cards. Interlaced Display output support. Serial Digital Video Out (SDVO) ports (2 channels) for additional CRT, LVDS panel, DVI, TV-Out and/or HDMI support via Advanced Digital Display 2 (ADD2) cards or Media Expansion Cards. Dual independent pipe support, Mirror and Dual independent display support Dual Monitor support with combinations of SDVO port devices and onboard CRT
Audio	Audio, 7.1 and 7.2 Channel High Definition Audio Codec using the Realtek ALC882 codec <ul style="list-style-type: none"> Line-out Line-in Surround output: SIDE, LFE, CEN, BACK and FRONT Microphone: MIC1 CDROM in SPDIF Interface Onboard speaker

(continues)

I/O Control	Winbond W83627DHG LPC Bus I/O Controller
Peripheral interfaces	<ul style="list-style-type: none"> • Eight USB 2.0 ports on I/O area • Two USB 2.0 ports on internal pinrows • Two Serial ports (RS232) • One Parallel port, SPP/EPP/ECP • Six Serial ATA-300 IDE interfaces • PS/2 keyboard and mouse ports
LAN Support	<ul style="list-style-type: none"> • 2x 10/100/1000Mbps/s LAN using Realtek RTL8111B controllers • RPL/PXE netboot supported. Wake On LAN (WOL) supported.
BIOS	<ul style="list-style-type: none"> • Kontron Technology / AMI BIOS (core version) • Support for Advanced Configuration and Power Interface (ACPI 2.0), Plug and Play <ul style="list-style-type: none"> ○ Suspend To Ram ○ Suspend To Disk ○ Intel Speed Step • Secure CMOS/ OEM Setup Defaults • "Always On" BIOS power setting • RAID Support (RAID modes 0, 1, 5 and 10) (for Linux O/S only RAID 0 and 1)
Expansion Capabilities	<ul style="list-style-type: none"> • PCI Bus routed to PCI slot(s) (PCI Local Bus Specification Revision 2.3) <ul style="list-style-type: none"> ○ KT965/Flex: 2 slots PCI 2.3, 32 bits, 33 MHz, 5V compliant ○ KT965/ATXP: 6 slots PCI 2.3, 32 bits, 33 MHz, 5V compliant ○ KT965/ATXE: 5 slots PCI 2.3, 32 bits, 33 MHz, 5V compliant • PCI-Express bus routed to PCI Express slot(s) (PCI Express 1.0a) <ul style="list-style-type: none"> ○ KT965/Flex: 1 slot PCI-Express x16, 1 slot PCI-Express x4 ○ KT965/ATXP: 1 slot PCI-Express x16 ○ KT965/ATXE: 1 slot PCI-Express x16, 1 slot PCI-Express x4 • Mini PCI-Express routed to mini PCI-Express connector Support for Mini PCI-Express modules with no components on backside. <ul style="list-style-type: none"> ○ KT965/Flex: None ○ KT965/ATXP: 1 slot mini PCI-Express x1 ○ KT965/ATXE: None • SMBus routed to FEATURE, PCI slot, PCI Express and mini-PCI Express connectors • LPC Bus routed to TPM connector • DDC Bus routed to LVDS and CRT connector • 8 x GPIOs (General Purpose I/Os) routed to FEATURE connector
Hardware Monitor Subsystem	<ul style="list-style-type: none"> • Smart Fan control system, support Thermal® and Speed® cruise for three onboard Fan control connectors: FAN_CPU, FAN_SYS and FEATURE • Three thermal inputs: CPU die temperature, System temperature and External temperature input routed to FEATURE connector. (Precision +/- 3°C) • Voltage monitoring • Intrusion detect input • SMI violations (BIOS) on HW monitor not supported. Supported by API (Windows).
Operating Systems Support	<ul style="list-style-type: none"> • Win2000 • WinXP • Win2003 • WinXP Embedded (limitations may apply) • Windows Vista • Linux: Fedora Core 5, Suse 10.01 (limitations may apply)

(continues)

Environmental Conditions	<p>Operating: 0°C – 50°C operating temperature (forced cooling). It is the customer's responsibility to provide sufficient airflow around each of the components to keep them within allowed temperature range. 10% - 90% relative humidity (non-condensing)</p> <p>Storage: -20°C – 70°C 5% - 95% relative humidity (non-condensing)</p> <p>Electro Static Discharge (ESD) / Radiated Emissions (EMI): All Peripheral interfaces intended for connection to external equipment are ESD/ EMI protected. EN 61000-4-2:2000 ESD Immunity EN55022:1998 class B Generic Emission Standard.</p> <p>Safety: UL 60950-1:2003, First Edition CSA C22.2 No. 60950-1-03 1st Ed. April 1, 2003 Product Category: Information Technology Equipment Including Electrical Business Equipment Product Category CCN: NWGQ2, NWGQ8 File number: E194252</p> <p>Theoretical MTBF: 189.130 hours @ 40°C for KT965/Flex 178.744 hours @ 40°C for KT965/ATXP 179.110 hours @ 40°C for KT965/ATXE</p> <p>Restriction of Hazardous Substances (RoHS): All boards in the KT965 family are RoHS compliant.</p> <p>Capacitor utilization: No Tantal capacitors on board Only Japanese brand Aluminium capacitors rated for 100°C used on board</p>
Battery	<p>Exchangeable 3.0V Lithium battery for onboard Real Time Clock and CMOS RAM. Manufacturer Panasonic / PN CR2032NL/LE, CR-2032L/BE or CR-2032L/BN.</p> <p>Expected minimum 5 years retention varies depending on temperature, actual application on/off rate and variation within chipset and other components.</p> <p>Approximately current draw is 3µA (no PSU connected).</p> <p>CAUTION: Danger of explosion if the battery is incorrectly replaced. Replace only with the same or equivalent type recommended by the manufacturer. Dispose of used batteries according to the manufacturer's instructions.</p>

3.2 System overview

The block diagram below shows the architecture and main components of the KT965 boards. The two key components on the board are the Intel® Q965 and Intel® ICH8DO Embedded Chipsets. Components shown shaded are optional depending on board type (KT965/Flex, /ATXP or /ATXE) and variants of the board.

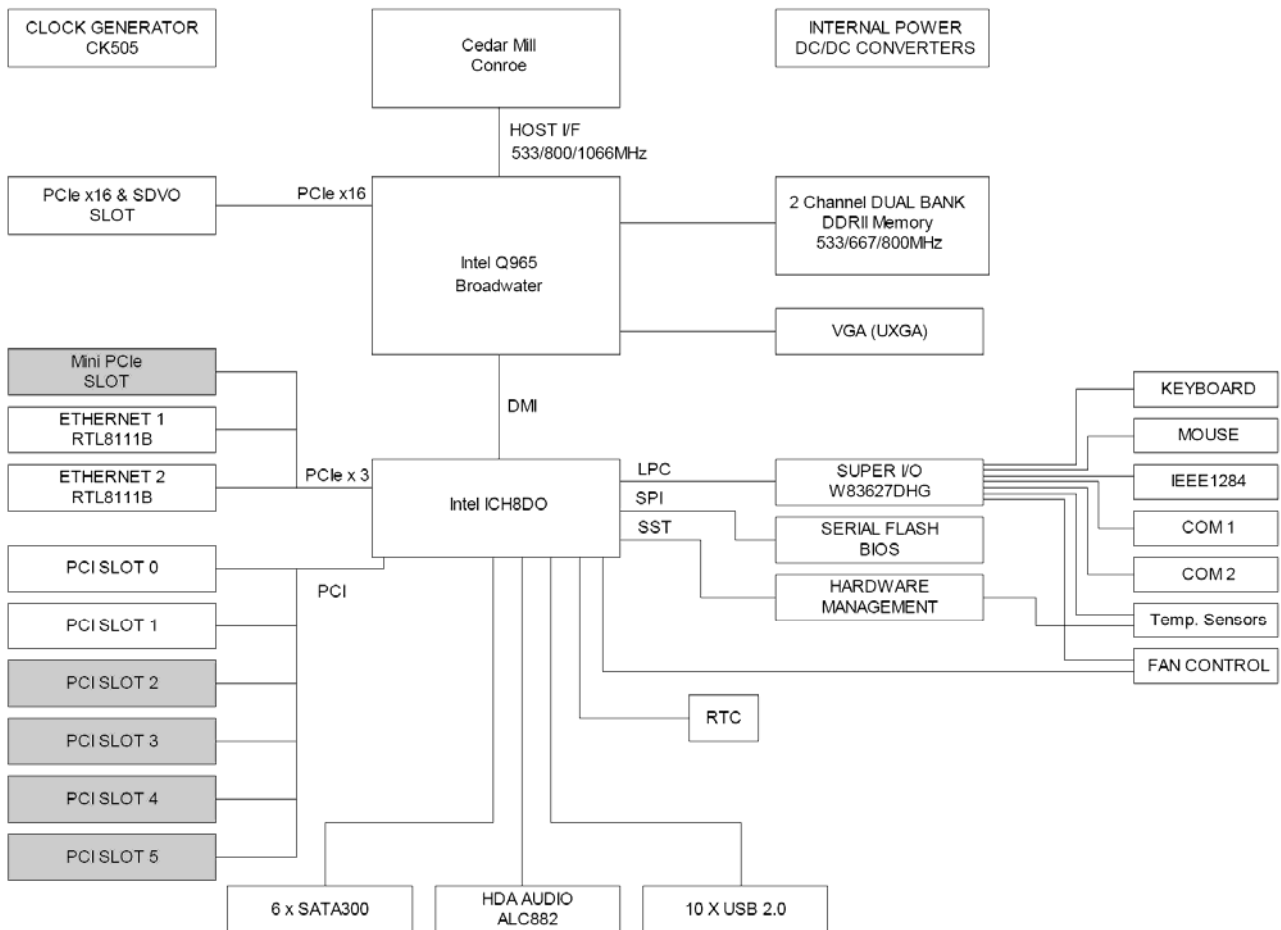

3.3 Processor support table.

The KT965/Flex, /ATXP and /ATXE are designed to support the following LGA775 processors:

Intel® Core™2 Quad Processor

Intel® Core™ 2 Duo Processor

Intel® Pentium® 4 Processor

Intel® Celeron®, Intel® Celeron® D Processor

Processor Brand	Clock Speed [GHz]	Bus Speed [MHz]	Processor Number	sSpec no.	Thermal Guideline [Watt]	Cache	Embedded
Intel® Core™2 Quad	2.66	1066	Q6700	SLACQ	95	8M	No
	2.40	1066	Q6600	SLACR	95	8M	No
	2.40	1066	Q6600	SL9UM	105	8M	No
Intel® Core™ 2 Duo (Conroe)	2.66	1066	E6700	SL9S7	65	4M	No
	2.66	1066	E6700	SL9ZF	65	4M	No
	2.66	1066	E6700	SLAPB	65	3M	No
	2.66	1066	E6700	SLB9X	65	3M	No
	2.53	1066	E7200	SLAPC	65	3M	No
	2.53	1066	E7200	SLAVN	65	3M	No
	2.40	1066	E6600	SL9SL	65	4M	No
	2.40	1066	E6600	SL9S8	65	4M	No
	2.13	1066	E6420	SLA4T	65	4M	Yes
	2.13	1066	E6400	SL9T9	65	2M	Yes
	2.13	1066	E6400	SLA97	65	2M	Yes
	2.13	1066	E6400	SL9S9	65	2M	Yes
	1.86	1066	E6320	SLA4U	65	4M	No
	1.86	1066	E6300	SL9SA	65	2M	No
	2.60	800	E4700	SLALT	65	2M	No
	1.80	800	E4300	SL9TB	65	2M	Yes
1.80	800	E2160	SLA3H	65	1M	No	
1.80	800	E2160	SLA8Z	65	1M	No	
1.80	800	E2160	SLA9Z	65	1M	No	
Intel® Pentium® 4 (Cedar Mill)	3.60	800	661		86	2M	No
	3.40	800	651	SL9KE	86 *	2M	Yes
	3.20	800	641		86	2M	No
	3.0	800	631		86	2M	No
Intel® Celeron® (Conroe-L)	2.0	800	440	SL9XL	35	512Kb	Yes
Intel® Celeron® D (Cedar Mill)	3.6	533	365		65	512Kb	No
	3.46	533	360		65	512Kb	No
	3.33	533	356		86	512Kb	No
	3.2	533	352	SL96P	86 *	512Kb	Yes
	3.06	533	347		86	512Kb	No

* 65W when D0 stepping.

3.4 System Memory support

The KT965 boards have four onboard DDR2 DIMM sockets and support the following memory features:

- 1.8V (only) 240-pin DDR2 SDRAM DIMMs with gold-plated contacts
- DDR2 800 (PC6400), DDR2 667 (PC5300) or DDR2 533 MHz (PC4200) SDRAM DIMMs
- DDR2 800 DIMMs with SPD timings of only 5-5-5 or 6-6-6 (tCL-tRCD-tRP)
- Unbuffered, single-sided or double-sided DIMMs with the following restriction: Double-sided DIMMs with x16 organization are not supported.
- 8 GB maximum total system memory using 64-bit OS. (Shared Video Memory is withdrawn).
- 4 GB maximum total system memory using 32-bit OS. ~3GB is displayed in System Properties. (Shared Video Memory is withdrawn).
- Minimum total system memory: 512 MB
- Non-ECC DIMMs
- Serial Presence Detect

The installed DDR2 SDRAM should support the Serial Presence Detect (SPD) data structure. This allows the BIOS to read and configure the memory controller for optimal performance. If non-SPD memory is used, the BIOS will attempt to configure the memory settings, but performance and reliability may be impacted.

Important: If only one Memory module is used then use DDR2 SLOT 1.

3.4.1 Memory Operating Frequencies

Regardless of the DIMM type used, the memory frequency will either be equal to or less than the processor system bus frequency. For example, if DDR2 800 memory is used with a 533 MHz system bus frequency processor, the memory will operate at 533 MHz. The table below lists the resulting operating memory frequencies based on the combination of DIMMs and processors.

DIMM Type	Processor system bus frequency	Resulting memory frequency
DDR2 533	533 MHz	533 MHz
DDR2 533	800 MHz	533 MHz
DDR2 533	1066 MHz	533 MHz
DDR2 667	533 MHz	533 MHz
DDR2 667	800 MHz	667 MHz
DDR2 667	1066 MHz	667 MHz
DDR2 800	533 MHz	533 MHz
DDR2 800	800 MHz	800 MHz
DDR2 800	1066 MHz	800 MHz

3.4.2 Memory Configurations

The KT965 boards support the following three types of memory organization:

Dual channel (Interleaved) mode. This mode offers the highest throughput. Dual channel mode is enabled when the installed memory capacities of both DIMM channels are equal. Technology and device width can vary from one channel to the other but the installed memory capacity for each channel must be equal. If different speed DIMMs are used between channels, the slowest memory timing will be used.

Single channel (Asymmetric) mode. This mode is equivalent to single channel bandwidth operation. This mode is used when only a single DIMM is installed or the memory capacities are unequal. Technology and device width can vary from one channel to the other. If different speed DIMMs are used between channels, the slowest memory timing will be used.

Flex mode. This mode provides the most flexible performance characteristics. The bottommost DRAM memory (the memory that is lowest within the system memory map) is mapped to dual channel operation; the topmost DRAM memory (the memory that is nearest to the 8 GB address space limit), if any, is mapped to single channel operation. Flex mode results in multiple zones of dual and single channel operation across the whole of DRAM memory. To use flex mode, it is necessary to populate both channels.

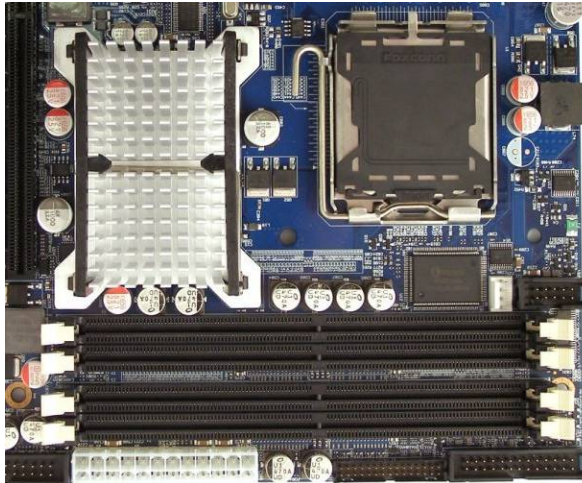

- ← Channel A, DDR2 DIMM 0 (SLOT 1)**
- ← Channel A, DDR2 DIMM 1 (SLOT 2)
- ← Channel B, DDR2 DIMM 0 (SLOT 3)
- ← Channel B, DDR2 DIMM 1 (SLOT 4)

****IMPORTANT NOTE:**

Regardless of the memory configuration used (dual channel, single channel, or flex mode), **DDR2 SLOT 1 must always be populated.**

The below tables shows examples of possible Memory slot configurations for the support of the various Memory modes.

Dual Channel (Interleaved) Mode Configurations			
Channel A		Channel B	
DDR2 DIMM 0 (SLOT 1)	DDR2 DIMM 1 (SLOT 2)	DDR2 DIMM 0 (SLOT 3)	DDR2 DIMM 1 (SLOT 4)
1 GB		1 GB	
512 MB	512 MB	1 GB	
512 MB	1 GB	512 MB	1 GB

In these examples the combined capacity of the two DIMMs in Channel A equals the combined capacity of the two DIMMs in Channel B.

Single Channel (Asymmetric) Mode Configurations			
Channel A		Channel B	
DDR2 DIMM 0 (SLOT 1)	DDR2 DIMM 1 (SLOT 2)	DDR2 DIMM 0 (SLOT 3)	DDR2 DIMM 1 (SLOT 4)
1 GB			
512 MB	1GB	1GB	

In these examples the combined capacity of the two DIMMs in Channel A does not equal the capacity of the DIMMs in Channel B.

Flex Mode Configurations			
Channel A		Channel B	
DDR2 DIMM 0 (SLOT 1)	DDR2 DIMM 1 (SLOT 2)	DDR2 DIMM 0 (SLOT 3)	DDR2 DIMM 1 (SLOT 4)
512 MB		1 GB	

The 512 MB DIMM in the Channel A, DIMM 0 socket and the lower 512 MB of the DIMM in the Channel B, DIMM 0 socket operate together in dual channel mode. The remaining (upper) 512 MB of the DIMM in Channel B operates in single channel mode.

3.5 KT965 Graphics Subsystem

The KT965 boards use the Intel Q965 Express chipset for the graphical control. This chipset contains two separate, mutually exclusive graphics options. Either the GMA 3000 graphics controller (contained within the 82Q965 GMCH) is used, or a PCI Express x16 add-in card can be used. When a PCI Express x16 add-in card is installed, the GMA 3000 graphics controller is disabled.

3.5.1 Intel GMA 3000 Graphics Controller

Features of the Intel GMA 3000 graphics controller includes:

- 667 MHz core frequency
- High performance 3-D setup and render engine
- High quality texture engine
 - DX9.0c* and OpenGL* 1.4 + extensions compliant
 - 32-bit and 16-bit Full Precision Floating Point Operations
 - Up to eight Multiple Render Targets (MRTs)
 - 128-bit floating point texture formats
 - Bilinear, Trilinear, and Anisotropic MipMap filtering
 - Alpha and luminance maps
- 3D Graphics Rendering enhancements
 - 1.3 dual texture GigaPixel/sec fill rate
 - 16 and 32 bit color
 - Maximum 3D supported resolution of 1600 x 1200 x 32 at 85 Hz
 - Vertex cache
 - Anti-aliased lines
 - OpenGL version 1.5 support with vertex buffer and EXT_Shadow extensions
- 2D Graphics enhancements
 - 8, 16, and 32 bit color
 - Optimized 256-bit BLT engine
 - Color space conversion
 - Anti-aliased lines
- Video
 - Hardware motion compensation for MPEG2 and HD video
 - Software DVD at 30 fps full screen
 - Motion adaptive de-interlacing
- Display
 - Integrated 24-bit 400 MHz RAMDAC
 - Up to 2048 x 1536 at 75 Hz refresh (QXGA)
 - DVI specification 1.0 compliant
 - Dual independent display options with digital display (using ADD2 card)
 - 180-degree hardware screen rotation
 - HDCP support
 - DDC2B compliant interface with Advanced Digital Display 2 card or Media Expansion Card (ADD2/MEC), support for TV-out/TV-in and DVI digital display connections
 - Supports flat panels up to 2048 x 1536 at 75 Hz (when in dual-channel mode) or digital CRT/HDTV at 1920 x 1080 at 85 Hz (with ADD2/MEC)
 - Two multiplexed SDVO port interfaces with 270 MHz pixel clocks using an ADD2/MEC card
- Dynamic Video Memory Technology (DVMT) support up to 256 MB

3.5.2 Dynamic Video Memory Technology (DVMT)

DVMT enables enhanced graphics and memory performance through highly efficient memory utilization. DVMT ensures the most efficient use of available system memory for maximum 2-D/3-D graphics performance. Up to 256 MB of system memory can be allocated to DVMT on systems that have 512 MB or more of total system memory installed. DVMT returns system memory back to the operating system when the

additional system memory is no longer required by the graphics subsystem.

DVMT will always use a minimal fixed portion of system physical memory (as set in the BIOS Setup) for compatibility with legacy applications. An example of this would be when using VGA graphics under DOS. Once loaded, the operating system and graphics drivers allocate additional system memory to the graphics buffer as needed for performing graphics functions.

IMPORTANT: The use of DVMT requires driver support by the operating system.

3.5.3 Advanced Digital Display (ADD2) card Support

The KT965 board routes two multiplexed SDVO ports that are each capable of driving up to a 200 MHz pixel clock to the PCI Express x16 connector. The SDVO ports can be paired for a dual channel configuration to support up to a 400 MHz pixel clock. When an ADD2 card is detected, the Intel GMA 3000 graphics controller is enabled and the PCI Express x16 connector is configured for SDVO mode. SDVO mode enables the SDVO ports to be accessed by the ADD2 card. An ADD2 card can either be configured to support simultaneous display with the primary VGA display or can be configured to support dual independent display as an extended desktop configuration with different color depths and resolutions.

ADD2 cards can be designed to support the following configurations:

- TV-Out (composite video)
- Transition Minimized Differential Signaling (TMDS) for DVI 1.0
- Low Voltage Differential Signaling (LVDS)
- Single device operating in dual channel mode
- VGA output
- HDTV output
- HDMI/UDI support (when used with the HD Audio Link)

Currently the following ADD2 cards are available

- P/N 820950, ADD2-Dual LVDS
- P/N 820951, ADD2-DVI-Dual-Internal
- P/N 820952, ADD2-DVI-Dual
- P/N 820953, ADD2-LVDS
- P/N 820954, ADD2-CRT
- P/N 820955, ADD2-DVI-Dual-Internal-C01
- P/N 820958, ADD2-DVI-Dual-Internal

Please visit the Kontron website (<http://emea.kontron.com/>) for details.

3.6 KT965 Power State Map

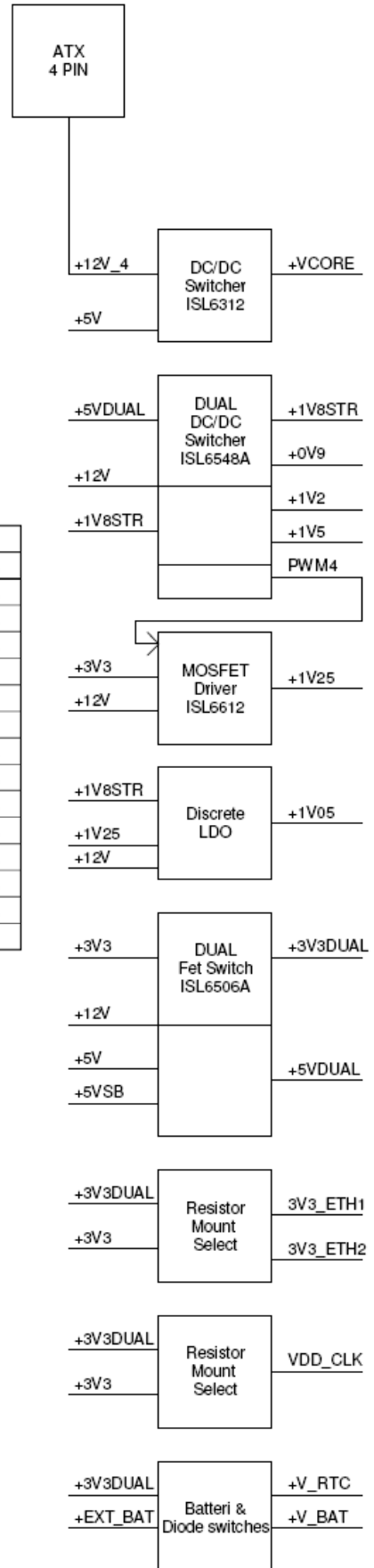
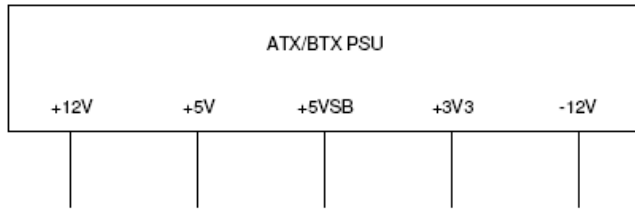

POWER NET/STATE	S0#	S3#	S4#	S5#
+3V3	X	NA	NA	NA
+5V	X	NA	NA	NA
+12V	X	NA	NA	NA
-12V	X	NA	NA	NA
+5VSB	X	X	X	X
+3V3DUAL	X	X	X	X
+5VDUAL	X	X	X	X
+VCORE	X	NA	NA	NA
+1V2	X	NA	NA	NA
+1V05	X	NA	NA	NA
+1V25	X	NA	NA	NA
+1V5	X	NA	NA	NA
+1V8STR	X	X	NA	NA
+0V9	X	NA	NA	NA

Continues

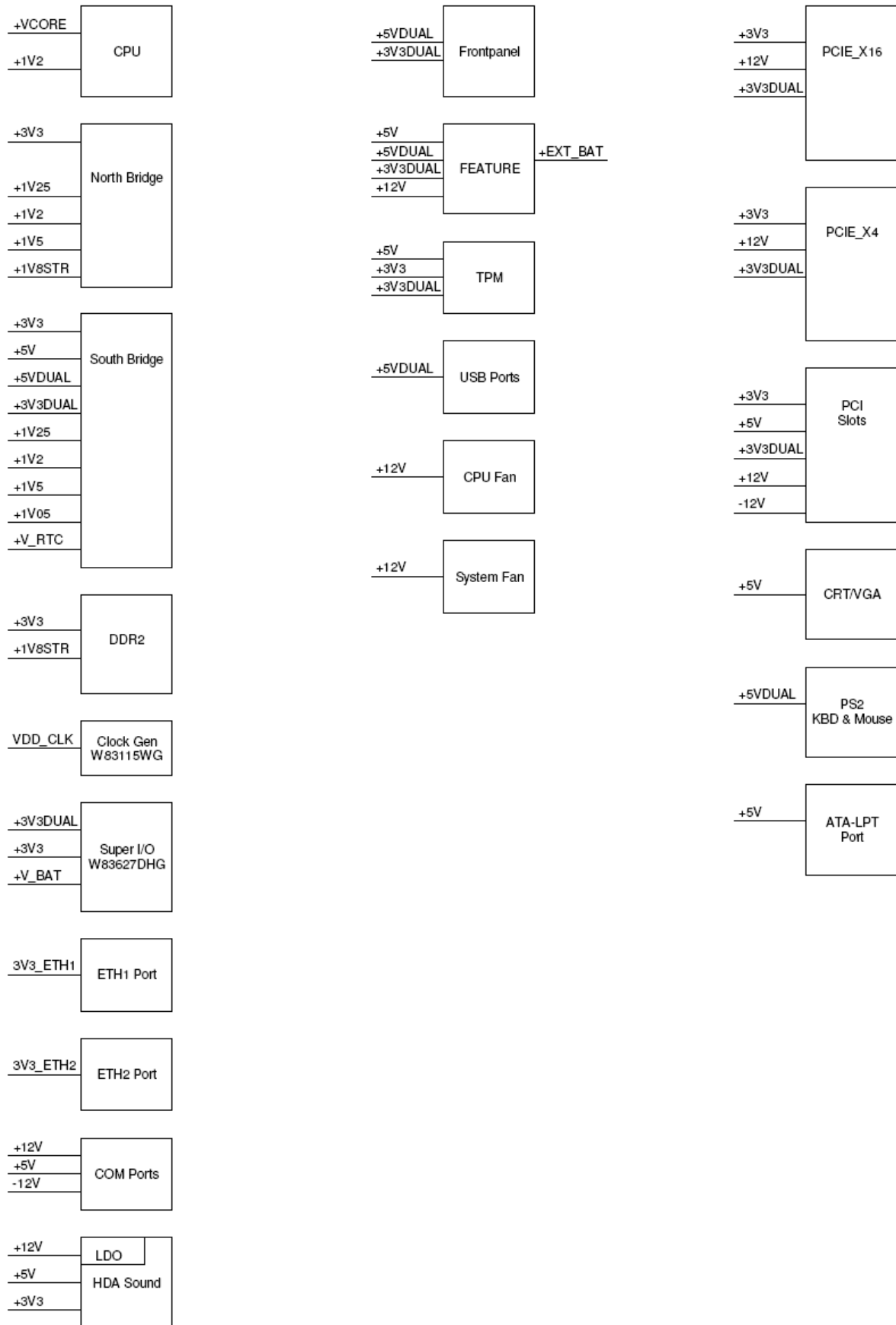

3.7 Power Consumption

In order to ensure safe operation of the board, the ATX power supply must monitor the supply voltage and shut down if the supplies are out of range – refer to the hardware manual for actual power specification.

The KT965/Flex board is powered through the ATX connector and the additional 12V separate supply for CPU as specified in the ATX specification; besides this the power supplied to the board must be within the ATX specification.

The requirements to the supply voltages are as follows:

Supply	Min	Max	Note
Vcc3	3.135V	3.465V	Should be $\pm 5\%$ for compliance with the ATX specification
Vcc	4.75V	5.25V	Should be $\pm 5\%$ for compliance with the ATX specification
+12V	11.4V	12.6V	Should be $\pm 5\%$ for compliance with the ATX specification
-12V	-13.2V	-10.8V	Should be $\pm 10\%$ for compliance with the ATX specification
-5V	-5,50V	-4.5V	Not required for the KT965/Flex board
5VSB	4.75V	5.25V	Should be $\pm 5\%$ for compliance with the ATX specification

Test system configuration

The following items are used in the test setup:

1. KT965/Flex equipped with CPU, RAM and 12V active cooler if required
2. ATX PSU
3. CRT, PS/2 keyboard & mouse and HD
4. Tektronix TDS 7404, P6345 probes
5. Fluke Current Probe 80i-100S AC/DC

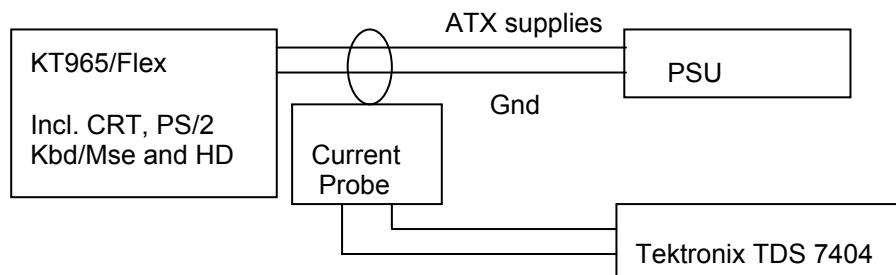

Note: The Power consumption of CRT, Fan and HD is not included.

Test results:

The power consumption of the KT965/Flex board is measured under:

- 1- DOS, idle, mean
- 2- WindowsXP, Running 3DMARK & CPU BURN, mean
- 3- WindowsXP, Running 3DMARK & CPU BURN, peak
- 4- S1, mean
- 5- S3, mean
- 6- S4, mean
- 7- Inrush, peak

KT965/Flex board mounted w/ 2.13GHz Core Duo & 1GB DDR2 Ram test results:

Test	Supply	Current draw	Power consumption
DOS, Idle, mean	+12V	1.51A	18.12W
	+5V	1.48A	7.4W
	+3V3	2.86A	9.44W
	-12V	0.004A	0.05W
	5VSB	0A	0W
	Total		
WinXP, 3DMARK2000 & CPUBURN, mean	+12V	4.35A	52.2W
	+5V	2.05A	10.25W
	+3V3	5.11A	16.83W
	-12V	0.004A	0.05W
	5VSB	0A	0W
	Total		
WinXP, 3DMARK2000 & CPUBURN, peak	+12V	4.64A	55.68W
	+5V	2.24A	11.2W
	+3V3	5.47A	18.05W
	-12V	0.004A	0.05W
	5VSB	0A	0W
	Total		
S1, mean	+12V	2.64A	31.68W
	+5V	1.31A	6.55W
	+3V3	2.66A	8.78W
	-12V	0.004A	0.05W
	5VSB	0A	0W
	Total		
S3, mean	+12V	0A	0W
	+5V	0A	0W
	+3V3	0A	0W
	-12V	0A	0W
	5VSB	0.21A	1.05W
	Total		
S4, mean	+12V	0A	0W
	+5V	0A	0W
	+3V3	0A	0W
	+ -12V	0A	0W
	5VSB	0.21A	1.05W
	Total		
Inrush, peak	+12V	6.88A	
	+5V	1.92A	
	+3V3	3.28A	
	-12V	0.08A	
	5VSB	3.6A	

4. Connector Definitions

The following sections provide pin definitions and detailed description of all on-board connectors.

The connector definitions follow the following notation:

Column name	Description
Pin	Shows the pin-numbers in the connector. The graphical layout of the connector definition tables is made similar to the physical connectors.
Signal	The mnemonic name of the signal at the current pin. The notation "XX#" states that the signal "XX" is active low.
Type	AI: Analog Input. AO: Analog Output. I: Input, TTL compatible if nothing else stated. IO: Input / Output. TTL compatible if nothing else stated. IOT: Bi-directional tristate IO pin. IS: Schmitt-trigger input, TTL compatible. IOC: Input / open-collector Output, TTL compatible. NC: Pin not connected. O: Output, TTL compatible. OC: Output, open-collector or open-drain, TTL compatible. OT: Output with tri-state capability, TTL compatible. LVDS: Low Voltage Differential Signal. PWR: Power supply or ground reference pins.
	Ioh: Typical current in mA flowing out of an output pin through a grounded load, while the output voltage is > 2.4 V DC (if nothing else stated). Iol: Typical current in mA flowing into an output pin from a VCC connected load, while the output voltage is < 0.4 V DC (if nothing else stated).
Pull U/D	On-board pull-up or pull-down resistors on input pins or open-collector output pins.
Note	Special remarks concerning the signal.

The abbreviation *TBD* is used for specifications which are not available yet or which are not sufficiently specified by the component vendors.

4.1 Connector layout

4.1.1 KT965/Flex

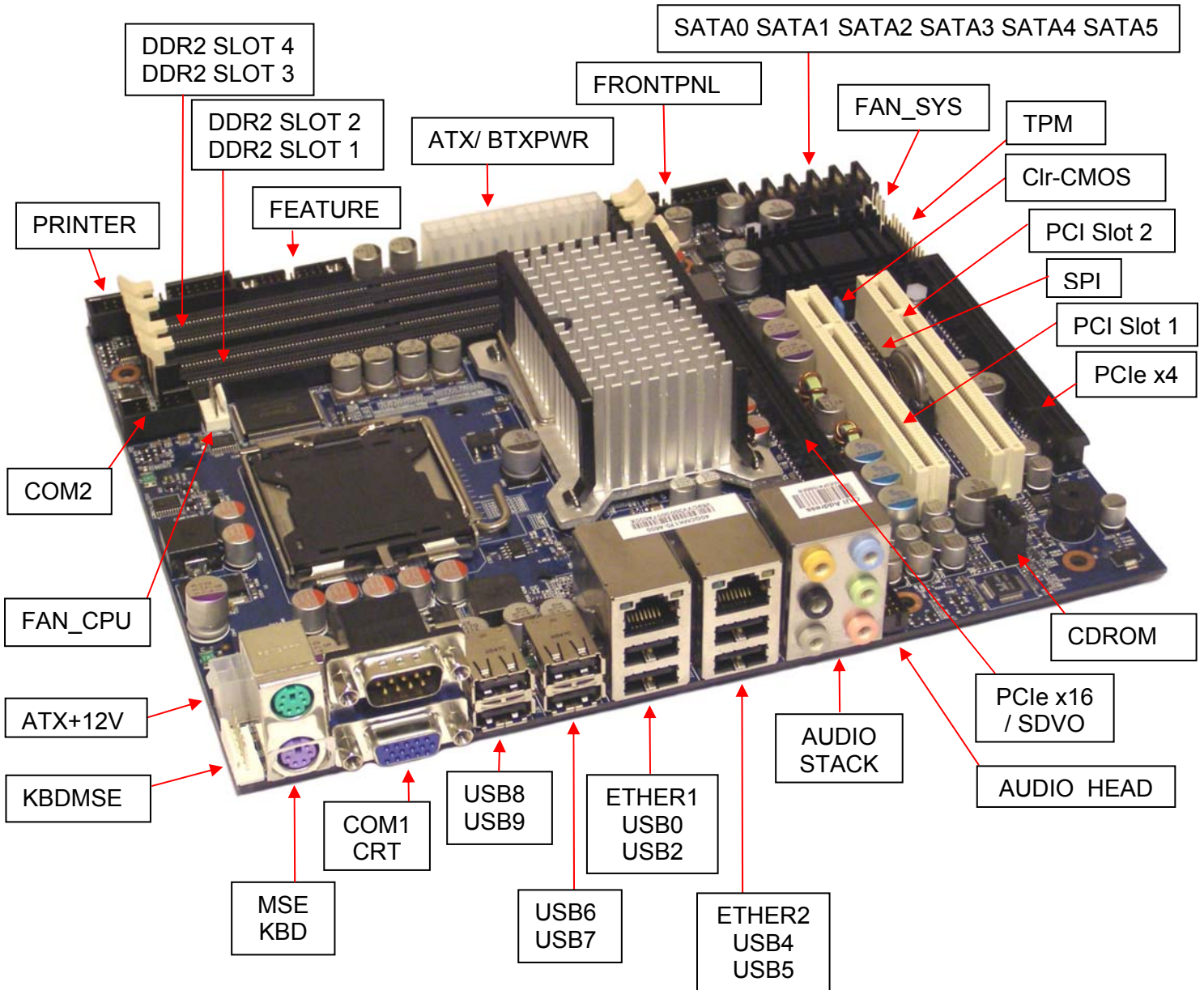

4.1.2 KT965/ATXP

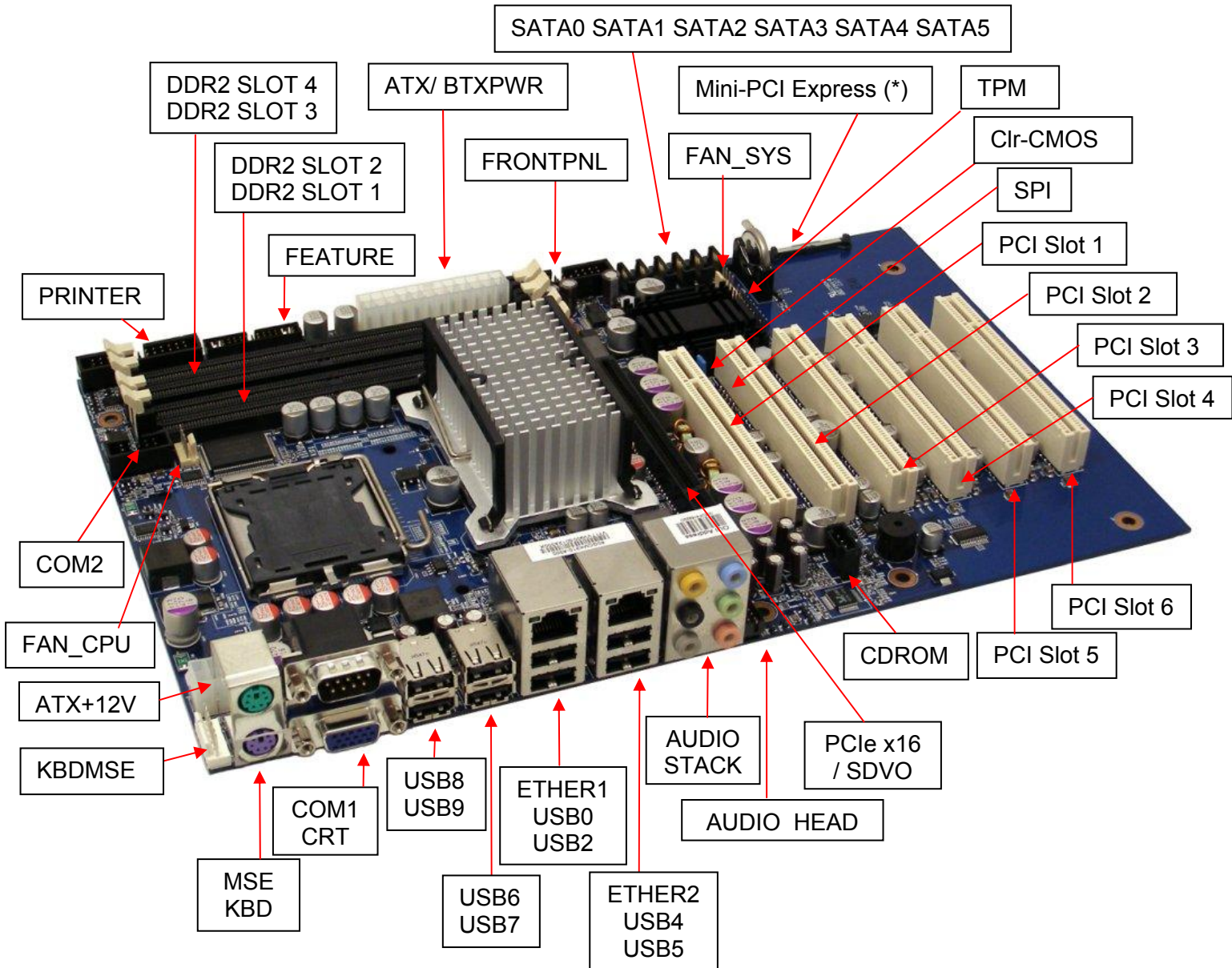

* Support for Mini PCI-Express modules with no components mounted on backside.

4.2 Power Connector (ATXPWR)

The KT965 boards are designed to be supplied from a standard ATX or BTX power supply.

ATX/ BTX Power Connector:

Note	Pull U/D	Ioh/Iol	Type	Signal	PIN		Signal	Type	Ioh/Iol	Pull U/D	Note
	-	-	PWR	3V3	12	24	GND	PWR	-	-	
			PWR	+12V	11	23	5V	PWR			
			PWR	+12V	10	22	5V	PWR			
	-	-	PWR	SB5V	9	21	5V	PWR	-	-	
	-	-	I	P_OK	8	20	-5V	PWR	-	-	1
	-	-	PWR	GND	7	19	GND	PWR	-	-	
	-	-	PWR	5V	6	18	GND	PWR	-	-	
	-	-	PWR	GND	5	17	GND	PWR	-	-	
	-	-	PWR	5V	4	16	PS_ON#	OC	-	-	
	-	-	PWR	GND	3	15	GND	PWR	-	-	
	-	-	PWR	3V3	2	14	-12V	PWR	-	-	
	-	-	PWR	3V3	1	13	3V3	PWR	-	-	

Note 1: -5V supply is not used onboard.

Note 2: Use of BTX supply not required for operation, but may be required to drive high-power PCI Express x16 Add cards.

ATX+12V Power Connector:

Note	Pull U/D	Ioh/Iol	Type	Signal	PIN		Signal	Type	Ioh/Iol	Pull U/D	Note
1	-	-	PWR	GND	1	3	+12V	PWR	-	-	1
1			PWR	GND	2	4	+12V	PWR			1

Note 1: Use of the 4-pin ATX+12V Power Connector is required for operation of the KT965 boards.

See chapter "Power Consumption" regarding input tolerances on 3.3V, 5V, SB5V, +12 and -12V (also refer to ATX specification).

Control signal description:

Signal	Description
P_OK	<p>P_OK is a power good signal and should be asserted high by the power supply to indicate that the +5VDC and +3.3VDC outputs are above the undervoltage thresholds of the power supply. When this signal is asserted high, there should be sufficient energy stored by the converter to guarantee continuous power operation within specification. Conversely, when the output voltages fall below the undervoltage threshold, or when mains power has been removed for a time sufficiently long so that power supply operation is no longer guaranteed, P_OK should be de-asserted to a low state. The recommended electrical and timing characteristics of the P_OK (PWR_OK) signal are provided in the <i>ATX12V Power Supply Design Guide</i>.</p> <p>It is strongly recommended to use an ATX or BTX supply with the KT965 boards, in order to implement the supervision of the 5V and 3V3 supplies. These supplies are not supervised onboard the KT965 boards.</p>
PS_ON#	Active low open drain signal from the board to the power supply to turn on the power supply outputs. Signal must be pulled high by the power supply.

4.4 Display Connectors

The KT965 board family provides onboard Analog CRT interface. Additionally the KT965 boards provides support for ADD2 cards through the onboard PCI Express x16 connector, with extension capability for support of DVI, LVDS, VGA, HDMI/UDI, TV-Out, etc.

If a PCI Express x16 Graphics add-in card is used, the onboard Graphics controller (GMA 3000) is disabled.

4.4.1 CRT Connector (CRT)

Note	Pull U/D	Ioh/Iol	Type	Signal	PIN		Signal	Type	Ioh/Iol	Pull U/D	Note
						6	GND	PWR	-	-	
	/75R	*	A0	RED	1	11	NC	-	-	-	
	/75R	*	A0	GREEN	2	12	DDCDAT	IO	TBD	2K2	
						8	GND	PWR	-	-	
	/75R	*	A0	BLUE	3	13	HSYNC	O	TBD		
						9	5V	PWR	-	-	1
	-	-	-	NC	4	14	VSYNC	O	TBD		
						10	GND	PWR	-	-	
	-	-	PWR	GND	5	15	DDCCLK	IO	TBD	2K2	

Note 1: The 5V supply in the CRT connector is fused by a 1.1A reset-able fuse.

Signal Description - CRT Connector:

Signal	Description
HSYNC	CRT horizontal synchronization output.
VSYNC	CRT vertical synchronization output.
DDCCLK	Display Data Channel Clock. Used as clock signal to/from monitors with DDC interface.
DDCDAT	Display Data Channel Data. Used as data signal to/from monitors with DDC interface.
RED	Analog output carrying the red color signal to the CRT. For 75 Ohm cable impedance.
GREEN	Analog output carrying the green color signal to the CRT. For 75 Ohm cable impedance.
BLUE	Analog output carrying the blue color signal to the CRT. For 75 Ohm cable impedance.
DIG-GND	Ground reference for HSYNC and VSYNC.
ANA-GND	Ground reference for RED, GREEN, and BLUE.

4.5 PCI-Express Connectors

The KT965 boards contains one 16-lane (x16) PCI Express port intended for an external PCI Express graphics card. The PCI Express port is compliant to the PCI Express* Base Specification revision 1.1. The x16 port operates at a frequency of 2.5 Gb/s on each lane while employing 8b/10b encoding; the port supports a maximum theoretical bandwidth of 40 Gb/s in each direction. The PCI Express (x16) interface is multiplexed with the SDVO ports.

Depending on the board variant the KT965 boards further supports one 4-lane (x4) PCI Express port.

The KT965/Flex supports one 16-lane (x16) PCI Express port and one 4-lane PCI Express (x16) port.

The KT965/ATXP supports one 16-lane (x16) PCI Express port.

The KT965/ATXE supports one 16-lane (x16) PCI Express port and one 4-lane PCI Express (x16) port.

4.5.1 PCI-Express x16/ SDVO connector

The KT965 boards supports one 16-lane (x16) PCI Express port for external PCI Express based graphics boards or ADD2 devices.

Note	Type	Signal	PIN		Signal	Type	Note
		+12V	B1	A1	NC		
		+12V	B2	A2	+12V		
		+12V	B3	A3	+12V		
		GND	B4	A4	GND		
		SMB_CLK	B5	A5	NC		
		SMB_DATA	B6	A6	NC		
		GND	B7	A7	NC		
		+3V3	B8	A8	NC		
		NC	B9	A9	+3V3		
		SB3V3	B10	A10	+3V3		
		WAKE#	B11	A11	RST#		
		NC	B12	A12	GND		
		GND	B13	A13	PCIE_x16 CLK		
		PEG_TXP[15] / SDVOB_RED	B14	A14	PCIE_x16 CLK#		
		PEG_TXN[15] / SDVOB_RED#	B15	A15	GND		
		GND	B16	A16	PEG_RXP[15] / SDVO_TVCLKIN		
		SDVO_CTRLCLK	B17	A17	PEG_RXN[15] / SDVO_TVCLKIN#		
		GND	B18	A18	GND		
		PEG_TXP[14] / SDVOB_GREEN	B19	A19	NC		
		PEG_TXN[14] / SDVOB_GREEN#	B20	A20	GND		
		GND	B21	A21	PEG_RXP[14] / SDVOB_INT		
		GND	B22	A22	PEG_RXN[14] / SDVOB_INT#		
		PEG_TXP[13] / SDVOB_BLUE	B23	A23	GND		
		PEG_TXN[13] / SDVOB_BLUE#	B24	A24	GND		
		GND	B25	A25	PEG_RXP[13] / SDVO_FLDSTALL		
		GND	B26	A26	PEG_RXN[13] / SDVO_FLDSTALL#		
		PEG_TXP[12] / SDVOB_CLKP	B27	A27	GND		
		PEG_TXN[12] / SDVOB_CLKN	B28	A28	GND		
		GND	B29	A29	PEG_RXP[12]		
		NC	B30	A30	PEG_RXN[12]		
		SDVO_CTRLDATA	B31	A31	GND		
		GND	B32	A32	NC		
		PEG_TXP[11] / SDVOC_RED	B33	A33	NC		
		PEG_TXN[11] / SDVOC_RED#	B34	A34	GND		
		GND	B35	A35	PEG_RXP[11]		
		GND	B36	A36	PEG_RXN[11]		
		PEG_TXP[10] / SDVOC_GREEN	B37	A37	GND		
		PEG_TXN[10] / SDVOC_GREEN#	B38	A38	GND		
		GND	B39	A39	PEG_RXP[10] / SDVOC_INT		
		GND	B40	A40	PEG_RXN[10] / SDVOC_INT#		
		PEG_TXP[9] / SDVOC_BLUE	B41	A41	GND		
		PEG_TXN[9] / SDVOC_BLUE#	B42	A42	GND		
		GND	B43	A43	PEG_RXP[9]		
		GND	B44	A44	PEG_RXN[9]		
		PEG_TXP[8] / SDVOC_CLKN	B45	A45	GND		
		PEG_TXN[8] / SDVOC_CLKP	B46	A46	GND		
		GND	B47	A47	PEG_RXP[8]		

(continues)

		PRSNT#2	B48	A48	PEG_RXN[8]		
		GND	B49	A49	GND		
		PEG_TXP[7]	B50	A50	NC		
		PEG_TXN[7]	B51	A51	GND		
		GND	B52	A52	PEG_RXP[7]		
		GND	B53	A53	PEG_RXN[7]		
		PEG_TXP[6]	B54	A54	GND		
		PEG_TXN[6]	B55	A55	GND		
		GND	B56	A56	PEG_RXP[6]		
		GND	B57	A57	PEG_RXN[6]		
		PEG_TXP[5]	B58	A58	GND		
		PEG_TXN[5]	B59	A59	GND		
		GND	B60	A60	PEG_RXP[5]		
		GND	B61	A61	PEG_RXN[5]		
		PEG_TXP[4]	B62	A62	GND		
		PEG_TXN[4]	B63	A63	GND		
		GND	B64	A64	PEG_RXP[4]		
		GND	B65	A65	PEG_RXN[4]		
		PEG_TXP[3]	B66	A66	GND		
		PEG_TXN[3]	B67	A67	GND		
		GND	B68	A68	PEG_RXP[3]		
		GND	B69	A69	PEG_RXN[3]		
		PEG_TXP[2]	B70	A70	GND		
		PEG_TXN[2]	B71	A71	GND		
		GND	B72	A72	PEG_RXP[2]		
		GND	B73	A73	PEG_RXN[2]		
		PEG_TXP[1]	B74	A74	GND		
		PEG_TXN[1]	B75	A75	GND		
		GND	B76	A76	PEG_RXP[1]		
		GND	B77	A77	PEG_RXN[1]		
		PEG_TXP[0]	B78	A78	GND		
		PEG_TXN[0]	B79	A79	GND		
		GND	B80	A80	PEG_RXP[0]		
		NC	B81	A81	PEG_RXN[0]		
		NC	B82	A82	GND		

4.5.2 PCI-Express x4 in a x16 connector

The KT965/Flex and KT965/ATXE boards supports one 4-lane PCI Express (x16) port.

Note	Type	Signal	PIN		Signal	Type	Note
		+12V	B1	A1	NC		
		+12V	B2	A2	+12V		
		+12V	B3	A3	+12V		
		GND	B4	A4	GND		
		SMB_CLK	B5	A5	NC		
		SMB_DATA	B6	A6	NC		
		GND	B7	A7	NC		
		+3V3	B8	A8	NC		
		NC	B9	A9	+3V3		
		SB3V3	B10	A10	+3V3		
		WAKE#	B11	A11	RST#		
		NC	B12	A12	GND		
		GND	B13	A13	PCIE_x4 CLK		
		PCIE_TXP[1]	B14	A14	PCIE_x4 CLK#		
		PCIE_TXN[1]	B15	A15	GND		
		GND	B16	A16	PCIE_RXP[1]		
		NC	B17	A17	PCIE_RXN[1]		
		GND	B18	A18	GND		
		PCIE_TXP[2]	B19	A19	NC		
		PCIE_TXN[2]	B20	A20	GND		
		GND	B21	A21	PCIE_RXP[2]		
		GND	B22	A22	PCIE_RXN[2]		
		PCIE_TXP[3]	B23	A23	GND		
		PCIE_TXN[3]	B24	A24	GND		
		GND	B25	A25	PCIE_RXP[3]		
		GND	B26	A26	PCIE_RXN[3]		
		PCIE_TXP[4]	B27	A27	GND		
		PCIE_TXN[4]	B28	A28	GND		
		GND	B29	A29	PCIE_RXP[4]		

(continues)

		NC	B30	A30	PCIE_RXN[4]		
		NC	B31	A31	GND		
		GND	B32	A32	NC		
		NC	B33	A33	NC		
		NC	B34	A34	GND		
		GND	B35	A35	NC		
		GND	B36	A36	NC		
		NC	B37	A37	GND		
		NC	B38	A38	GND		
		GND	B39	A39	NC		
		GND	B40	A40	NC		
		NC	B41	A41	GND		
		NC	B42	A42	GND		
		GND	B43	A43	NC		
		GND	B44	A44	NC		
		NC	B45	A45	GND		
		NC	B46	A46	GND		
		GND	B47	A47	NC		
		NC	B48	A48	NC		
		GND	B49	A49	GND		
		NC	B50	A50	NC		
		NC	B51	A51	GND		
		GND	B52	A52	NC		
		GND	B53	A53	NC		
		NC	B54	A54	GND		
		NC	B55	A55	GND		
		GND	B56	A56	NC		
		GND	B57	A57	NC		
		NC	B58	A58	GND		
		NC	B59	A59	GND		
		GND	B60	A60	NC		
		GND	B61	A61	NC		
		NC	B62	A62	GND		
		NC	B63	A63	GND		
		GND	B64	A64	NC		
		GND	B65	A65	NC		
		NC	B66	A66	GND		
		NC	B67	A67	GND		
		GND	B68	A68	NC		
		GND	B69	A69	NC		
		NC	B70	A70	GND		
		NC	B71	A71	GND		
		GND	B72	A72	NC		
		GND	B73	A73	NC		
		NC	B74	A74	GND		
		NC	B75	A75	GND		
		GND	B76	A76	NC		
		GND	B77	A77	NC		
		NC	B78	A78	GND		
		NC	B79	A79	GND		
		GND	B80	A80	NC		
		NC	B81	A81	NC		
		NC	B82	A82	GND		

4.5.3 miniPCI-Express connector

The KT965/ATXP board supports one miniPCI Express port compliant to the Mini PCI Specification, Revision 1.0.

This allows for implementation for small form factor PCI cards also referred to as Mini PCI Cards.

Note	Type	Signal	PIN		Signal	Type	Note
		WAKE#	1	2	+3V3		
		NC	3	4	GND		
		NC	5	6	+1.5V		
		NC	7	8	NC		
		GND	9	10	NC		
		PCIE_mini CLK#	11	12	NC		
		PCIE_mini CLK	13	14	NC		
		GND	15	16	NC		
		NC	17	18	GND		
		NC	19	20	W_Disable		
		GND	21	22	RST#		
		PCIE_RXN	23	24	+3V3		
		PCIE_RXP	25	26	GND		
		GND	27	28	+1.5V		
		GND	29	30	SMB_CLK		
		PCIE_TXN	31	32	SMB_DATA		
		PCIE_TXP	33	34	GND		
		GND	35	36	NC		
		NC	37	38	NC		
		NC	39	40	GND		
		NC	41	42	NC		
		NC	43	44	NC		
		NC	45	46	NC		
		NC	47	48	+1.5V		
		NC	49	50	GND		
		NC	51	52	+3V3		

4.6 Serial ATA harddisk interface

The KT965 boards have an integrated SATA Host controller that supports independent DMA operation on six ports and data transfer rates of up to 3.0Gb/s (300MB/s). The SATA controller supports AHCI mode and has integrated RAID functionality with support for RAID modes 0, 1, 5 and 10 (Linux O/S only support for RAID 0 and 1).

The board provides six Serial ATA (SATA) connectors, which support one device per connector.

The ICH8DO's Serial ATA controller offers six independent Serial ATA ports with a theoretical maximum transfer rate of 3 Gbits/sec per port. One device can be installed on each port for a maximum of six Serial ATA devices. A point-to-point interface is used for host to device connections, unlike Parallel ATA IDE which supports a master/slave configuration and two devices per channel.

For compatibility, the underlying Serial ATA functionality is transparent to the operating system. The Serial ATA controller can operate in both legacy and native modes. In legacy mode, standard IDE I/O and IRQ resources are assigned (IRQ 14 and 15). In Native mode, standard PCI Conventional bus resource steering is used. Native mode is the preferred mode for configurations using the Windows XP and Windows 2000 operating systems.

The KT965 supports the following RAID (Redundant Array of Independent Drives) levels:

- RAID 0 - data striping
- RAID 1 - data mirroring
- RAID 0+1 (or RAID 10) - data striping and mirroring
- RAID 5 - distributed parity

Limitations depending on Target Operating System apply.

4.6.1 SATA Hard Disk Connector (SATA0, SATA1, SATA2, SATA3, SATA4, SATA5)

SATA:

PIN	Signal	Type	Ioh/Iol	Pull U/D	Note
Key					
1	GND	PWR	-	-	
2	SATA* TX+				
3	SATA* TX-				
4	GND	PWR	-	-	
5	SATA* RX-				
6	SATA* RX+				
7	GND	PWR	-	-	

The signals used for the primary Serial ATA harddisk interface are the following:

Signal	Description
SATA* RX+ SATA* RX-	Host transmitter differential signal pair
SATA* TX+ SATA* TX-	Host receiver differential signal pair

“*” specifies 0, 1, 2, 3, 4 and 5 depending on SATA port.

All of the above signals are compliant to [4].

4.7 Printer Port Connector (PRINTER).

The signal definition in standard printer port mode is as follows:

Note	Pull U/D	Ioh/Iol	Type	Signal	PIN		Signal	Type	Ioh/Iol	Pull U/D	Note
	2K2	(24)/24	OC(O)	STB#	1	2	AFD#	OC(O)	(24)/24	2K2	
	2K2	24/24	IO	PD0	3	4	ERR#	I	-	2K2	
	2K2	24/24	IO	PD1	5	6	INIT#	OC(O)	(24)/24	2K2	
	2K2	24/24	IO	PD2	7	8	SLIN#	OC(O)	(24)/24	2K2	
	2K2	24/24	IO	PD3	9	10	GND	PWR	-	-	
	2K2	24/24	IO	PD4	11	12	GND	PWR	-	-	
	2K2	24/24	IO	PD5	13	14	GND	PWR	-	-	
	2K2	24/24	IO	PD6	15	16	GND	PWR	-	-	
	2K2	24/24	IO	PD7	17	18	GND	PWR	-	-	
	2K2	-	I	ACK#	19	20	GND	PWR	-	-	
	2K2	-	I	BUSY	21	22	GND	PWR	-	-	
	2K2	-	I	PE	23	24	GND	PWR	-	-	
	2K2	-	I	SLCT	25	26	GND	PWR	-	-	

The interpretation of the signals in standard Centronics mode (SPP) with a printer attached is as follows:

Signal	Description
PD7..0	Parallel data bus from PC board to printer. The data lines are able to operate in PS/2 compatible bi-directional mode.
SLIN#	Signal to select the printer sent from CPU board to printer.
SLCT	Signal from printer to indicate that the printer is selected.
STB#	This signal indicates to the printer that data at PD7..0 are valid.
BUSY	Signal from printer indicating that the printer cannot accept further data.
ACK#	Signal from printer indicating that the printer has received the data and is ready to accept further data.
INIT#	This active low output initializes (resets) the printer.
AFD#	This active low output causes the printer to add a line feed after each line printed.
ERR#	Signal from printer indicating that an error has been detected.
PE#	Signal from printer indicating that the printer is out of paper.

The printer port additionally supports operation in the EPP and ECP mode as defined in [3].

4.8 Serial Ports

Two RS232 serial ports are available on the KT965 boards

The typical interpretation of the signals in the COM ports is as follows:

Signal	Description
TxD	Transmitte Data, sends serial data to the communication link. The signal is set to a marking state on hardware reset when the transmitter is empty or when loop mode operation is initiated.
RxD	Receive Data, receives serial data from the communication link.
DTR	Data Terminal Ready, indicates to the modem or data set that the on-board UART is ready to establish a communication link.
DSR	Data Set Ready, indicates that the modem or data set is ready to establish a communication link.
RTS	Request To Send, indicates to the modem or data set that the on-board UART is ready to exchange data.
CTS	Clear To Send, indicates that the modem or data set is ready to exchange data.
DCD	Data Carrier Detect, indicates that the modem or data set has detected the data carrier.
RI	Ring Indicator, indicates that the modem has received a telephone-ringing signal.

The connector pinout for each operation mode is defined in the following sections.

4.8.1 Com1 (Port1) DB9 Connector.

Note	Pull U/D	Ioh/Iol	Type	Signal	PIN	Signal	Type	Ioh/Iol	Pull U/D	Note
	-	-	PWR	GND	5					
					9	RI	I	-	/5K	
	-		O	DTR	4					
					8	CTS	I	-	/5K	
	-		O	TxD	3					
					7	RTS	O		-	
	/5K	-	I	RxD	2					
					6	DSR	I	-	/5K	
	/5K	-	I	DCD	1					

4.8.2 Com2 Pin Header Connector.

The pinout of Serial ports Com2 is as follows:

Note	Pull U/D	Ioh/Iol	Type	Signal	PIN	Signal	Type	Ioh/Iol	Pull U/D	Note
		-	I	DCD	1 2	DSR	I	-		
		-	I	RxD	3 4	RTS	O		-	
	-		O	TxD	5 6	CTS	I	-		
	-		O	DTR	7 8	RI	I	-		
	-	-	PWR	GND	9 10	5V	PWR	-	-	1

Note 1: The Com2 header 5V supply is fused with a 1.1A resettable fuse.

If the DB9 adapter (ribbon cable) is used, the DB9 pinout will be identical to the pinout of Serial Com1

4.9 Ethernet connectors.

The KT965 boards supports 2 channels of 10/100/1000Mb Ethernet RTL8111B LAN controllers.

In order to achieve the specified performance of the Ethernet port, Category 5 twisted pair cables must be used with 10/100MB and Category 5E, 6 or 6E with 1Gb LAN networks.

The signals for the Ethernet ports are as follows:

Signal	Description
MDI[0]+	In MDI mode, this is the first pair in 1000Base-T, i.e. the BI_DA+/- pair, and is the transmit pair in 10Base-T and 100Base-TX. In MDI crossover mode, this pair acts as the BI_DB+/- pair, and is the receive pair in 10Base-T and 100Base-TX.
MDI[0]-	
MDI[1]+	In MDI mode, this is the second pair in 1000Base-T, i.e. the BI_DB+/- pair, and is the receive pair in 10Base-T and 100Base-TX. In MDI crossover mode, this pair acts as the BI_DA+/- pair, and is the transmit pair in 10Base-T and 100Base-TX.
MDI[1]-	
MDI[2]+	In MDI mode, this is the third pair in 1000Base-T, i.e. the BI_DC+/- pair.
MDI[2]-	In MDI crossover mode, this pair acts as the BI_DD+/- pair.
MDI[3]+	In MDI mode, this is the fourth pair in 1000Base-T, i.e. the BI_DD+/- pair.
MDI[3]-	In MDI crossover mode, this pair acts as the BI_DC+/- pair.

Note: MDI = Media Dependent Interface.

4.9.1 Ethernet connector 1 (ETHER1)

Ethernet connector 1 is mounted together with USB Ports 0 and 2.

The pinout of the RJ45 connector is as follows:

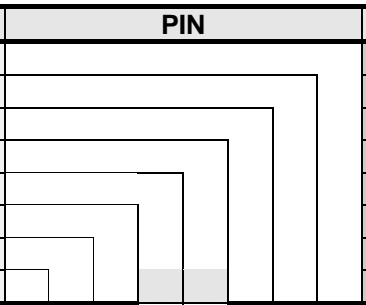
Signal	PIN	Type	Ioh/Iol	Note	
MDI0+					
MDI0-					
MDI1+					
MDI2+					
MDI2-					
MDI1-					
MDI3+					
MDI3-					
		8			
		7			
		6			
		5			
		4			
		3			
		2			
		1			

4.9.2 Ethernet connector 2 (ETHER2)

Ethernet connector 2 is mounted together with USB Ports 4 and 5.

The pinout of the RJ45's connector are as follows:

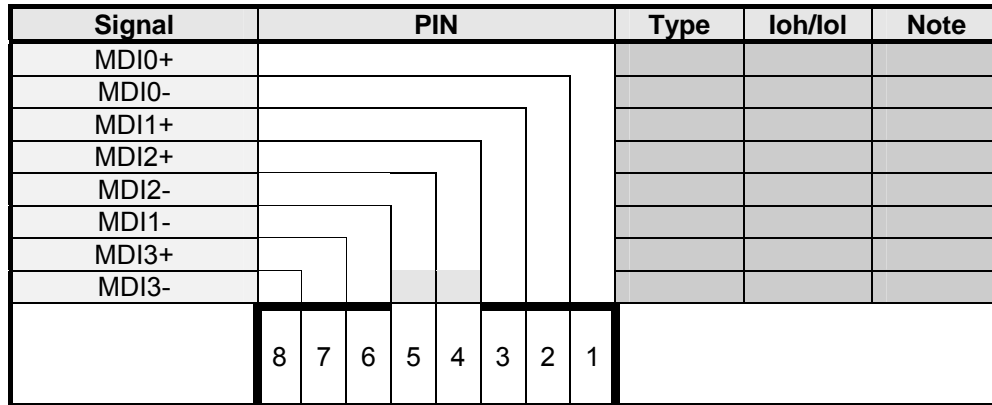
Signal	PIN								Type	loh/loi	Note
MDI0+											
MDI0-											
MDI1+											
MDI2+											
MDI2-											
MDI1-											
MDI3+											
MDI3-											
	8	7	6	5	4	3	2	1			

4.10 USB Connector (USB)

The KT965 boards contains two Enhanced Host Controller Interface (EHCI) host controllers that supports USB 2.0 allowing data transfers up to 480Mb/s. The KT965 boards also contains five Universal Host Controller Interface (UHCI Revision 1.1) controllers that support USB full-speed and low-speed signaling. The KT965 boards supports a total of ten USB 2.0 ports. All ten ports are high-speed, full-speed, and low-speed capable and USB Legacy mode is supported.

Over-current detection on all ten USB ports is supported.

USB Port 0 and 2 are supplied on the combined ETHER1, USB0, USB2 connector. USB Ports 1 and 3 are supplied on the internal FRONTPNL connector; please refer to the FRONTPNL connector section for the pin-out.

USB Port 4 and 5 are supplied on the combined ETHER2, USB4, USB5 connector.

USB Port 6 and 7 are supplied on the USB6, USB7 frontpanel connector.

USB Port 8 and 9 are supplied on the USB8, USB9 frontpanel connector.

Note: It is recommended to use only High-/Full-Speed USB cable, specified in USB2.0 standard:

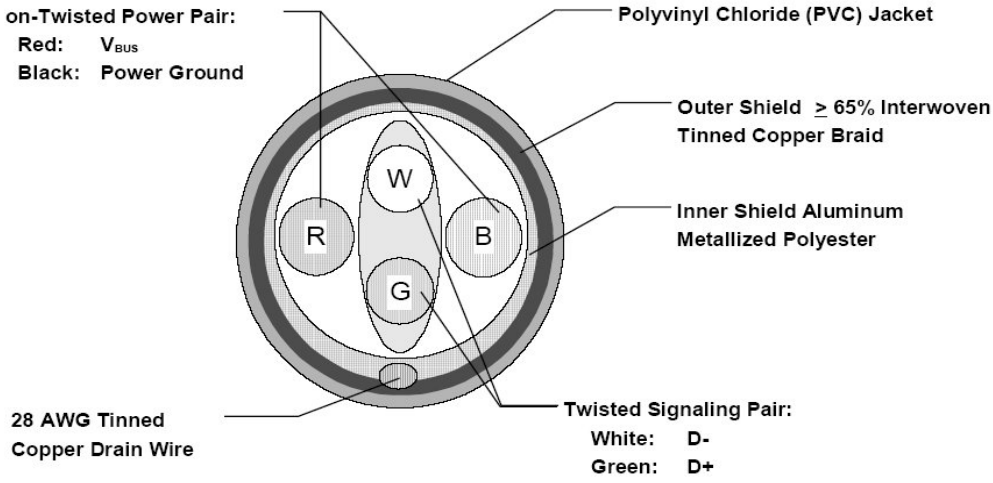

4.10.1 USB Connector 0/2 (USB0/2)

USB Ports 0 and 2 are mounted together with ETHER1 ethernet port.

Note	Pull U/D	Ioh/Iol	Type	Signal	PIN				Signal	Type	Ioh/Iol	Pull U/D	Note
					1	2	3	4					
1	- /15K	- 0.25/2	PWR IO	5V/SB5V USB0-					GND USB0+	PWR IO	- 0.25/2	- /15K	
					1	2	3	4					
1	- /15K	- 0.25/2	PWR IO	5V/SB5V USB2-					GND USB2+	PWR IO	- 0.25/2	- /15K	

Note 1: The 5V supply for the USB devices is on-board fused with a 2.0A reset-able fuse. The supply is common for the two channels. SB5V is supplied during power down to allow wakeup on USB device activity. In order to meet the requirements of USB standard, the 5V input supply must be at least 5.00V.

Signal	Description
USB0+ USB0- USB2+ USB2-	Differential pair works as Data/Address/Command Bus.
USB5V	5V supply for external devices. Fused with 2.0A reset-able fuse.

4.10.2 USB Connector 4/5 (USB4/5)

USB Ports 4 and 5 are mounted together with ETHER2.

Note	Pull U/D	Ioh/Iol	Type	Signal	PIN				Signal	Type	Ioh/Iol	Pull U/D	Note
					1	2	3	4					
1	- /15K	- 0.25/2	PWR IO	5V/SB5V USB5-					GND USB5+	PWR IO	- 0.25/2	- /15K	
					1	2	3	4					
1	- /15K	- 0.25/2	PWR IO	5V/SB5V USB4-					GND USB4+	PWR IO	- 0.25/2	- /15K	

Note 1: The 5V supply for the USB devices is on-board fused with a 2.0A reset-able fuse. The supply is common for the two channels. SB5V is supplied during power down to allow wakeup on USB device activity. In order to meet the requirements of USB standard, the 5V input supply must be at least 5.00V.

Signal	Description
USB4+ USB4- USB5+ USB5-	Differential pair works as Data/Address/Command Bus.
USB5V	5V supply for external devices. Fused with 2.0A reset-able fuse.

4.10.3 USB Connector 6/7 (USB6/7)

USB Ports 6 and 7 are available on the I/O frontpanel.

Note	Pull U/D	Ioh/Iol	Type	Signal	PIN				Signal	Type	Ioh/Iol	Pull U/D	Note
					1	2	3	4					
1	- /15K	- 0.25/2	PWR IO	5V/SB5V USB6-					GND USB6+	PWR IO	- 0.25/2	- /15K	
					1	2	3	4					
1	- /15K	- 0.25/2	PWR IO	5V/SB5V USB7-					GND USB7+	PWR IO	- 0.25/2	- /15K	

Note 1: The 5V supply for the USB devices is on-board fused with a 2.0A reset-able fuse. The supply is common for the two channels. SB5V is supplied during power down to allow wakeup on USB device activity. In order to meet the requirements of USB standard, the 5V input supply must be at least 5.00V.

Signal	Description
USB6+ USB6- USB7+ USB7-	Differential pair works as Data/Address/Command Bus.
USB5V	5V supply for external devices. Fused with 2.0A reset-able fuse.

4.10.4 USB Connector 8/9 (USB8/9)

USB Ports 8 and 9 are available on the I/O frontpanel.

Note	Pull U/D	Ioh/Iol	Type	Signal	PIN				Signal	Type	Ioh/Iol	Pull U/D	Note
					1	2	3	4					
1	- /15K	- 0.25/2	PWR IO	5V/SB5V USB8-					GND USB8+	PWR IO	- 0.25/2	- /15K	
					1	2	3	4					
1	- /15K	- 0.25/2	PWR IO	5V/SB5V USB9-					GND USB9+	PWR IO	- 0.25/2	- /15K	

Note 1: The 5V supply for the USB devices is on-board fused with a 2.0A reset-able fuse. The supply is common for the two channels. SB5V is supplied during power down to allow wakeup on USB device activity. In order to meet the requirements of USB standard, the 5V input supply must be at least 5.00V.

Signal	Description
USB8+ USB8- USB9+ USB9-	Differential pair works as Data/Address/Command Bus.
USB5V	5V supply for external devices. Fused with 2.0A reset-able fuse.

4.11 Audio Connector

The onboard Audio circuit implements 7.1+2 Channel High Definition Audio with UAA (Universal Audio Architecture), featuring five 24-bit stereo DACs and three 20-bit stereo ADCs.

4.11.1 Audio Line-in, Line-out and Microphone

Audio Line-in, Line-out and Microphone are available in the stacked audio jack connector. Below is shown audio stack configuration when configured for 8-channel audio.

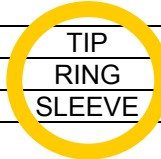
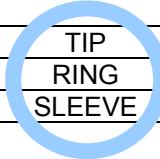
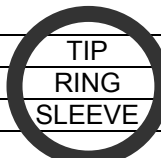
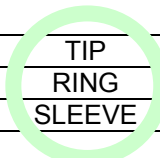
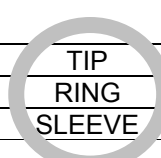
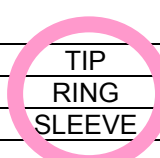
Note	Type	Signal			Signal	Type	Note		
	OA	CEN-OUT			LINE1-IN-L	IA	1		
	OA	LFE-OUT			RING	RING	LINE1-IN-R	IA	1
	PWR	GND			SLEEVE	SLEEVE	GND	PWR	
	OA	REAR-OUT-L			FRONT-OUT-L	OA			
	OA	REAR-OUT-R			RING	RING	FRONT-OUT-R	OA	
	PWR	GND			SLEEVE	SLEEVE	GND	PWR	
	OA	SIDE-OUT-L			MIC1-L	IA	1		
	OA	SIDE-OUT-R			RING	RING	MIC1-R	IA	1
	PWR	GND			SLEEVE	SLEEVE	GND	PWR	

Note 1: Signals are shorted to GND internally in the connector, when jack-plug not inserted.

Signal descriptions

Signal	Description	Note
FRONT-OUT-L	Front Speakers (Speaker Out Left).	
FRONT-OUT-R	Front Speakers (Speaker Out Right).	
REAR-OUT-L	Rear Speakers (Surround Out Left).	
REAR-OUT-R	Rear Speakers (Surround Out Right).	
SIDE-OUT-L	Side speakers (Surround Out Left)	
SIDE-OUT-R	Side speakers (Surround Out Right)	
CEN-OUT	Center Speaker (Center Out channel).	
LFE-OUT	Subwoofer Speaker (Low Freq. Effect Out).	
MIC1	MIC Input 1	
LINE1-IN	Line in 1 signals	

Audio 2, 4, 6, or 8-channel configuration

Port	2-channel	4-channel	6-channel	8-channel
Light Blue	Line in	Line in	Line in	Line in
Lime	Line out	Front speaker out	Front speaker out	Front speaker out
Pink	Mic in	Mic in	Mic in	Mic in
Gray	-	-	-	Side speaker out
Black	-	Rear speaker out	Rear speaker out	Rear speaker out
Yellow Orange	-	-	Center/ Subwoofer	Center/ Subwoofer

4.11.2 CD-ROM Audio input (CDROM)

CD-ROM audio input may be connected to this connector. It may also be used as a secondary line-in signal.

PIN	Signal	Type	Ioh/Iol	Pull U/D	Note
1	CD_Left	IA	-	-	1
2	CD_GND	IA	-	-	
3	CD_GND	IA	-	-	
4	CD_Right	IA	-	-	1

Note 1: The definition of which pins are use for the Left and Right channels is not a worldwide accepted standard. Some CDROM cable kits expect reverse pin order.

Signal	Description
CD_Left CD_Right	Left and right CD audio input lines or secondary Line-in.
CD_GND	Analogue GND for Left and Right CD. (This analogue GND is not shorted to the general digital GND on the board).

4.11.3 AUDIO Header (AUDIO_HEAD)

Note	Pull U/D	Ioh/Iol	Type	Signal	PIN		Signal	Type	Ioh/Iol	Pull U/D	Note
				LFE-OUT	1	2	CEN-OUT				
				AAGND	3	4	AAGND				
				FRONT-OUT-L	5	6	FRONT-OUT-R				
				AAGND	7	8	AAGND				
				REAR-OUT-L	9	10	REAR-OUT-R				
				SIDE-OUT-L	11	12	SIDE-OUT-R				
				AAGND	13	14	AAGND				
				MIC1-L	15	16	MIC1-R				
				AAGND	17	18	AAGND				
				LINE1-IN-L	19	20	LINE1-IN-R				
				NC	21	22	AAGND				
	-	-	PWR	GND	23	24	SPDIF-IN				
				SPDIF-OUT	25	26	GND	PWR	-	-	

Signal	Description	Note
FRONT-OUT-L	Front Speakers (Speaker Out Left).	
FRONT-OUT-R	Front Speakers (Speaker Out Right).	
REAR-OUT-L	Rear Speakers (Surround Out Left).	
REAR-OUT-R	Rear Speakers (Surround Out Right).	
SIDE-OUT-L	Side speakers (Surround Out Left)	
SIDE-OUT-R	Side speakers (Surround Out Right)	
CEN-OUT	Center Speaker (Center Out channel).	
LFE-OUT	Subwoofer Speaker (Low Freq. Effect Out).	
NC	No connection	
MIC1	MIC Input 1	
LINE1-IN	Line in 1 signals	
F-SPDIF-IN	S/PDIF Input	
F-SPDIF-OUT	S/PDIF Output	
AAGND	Audio Analogue ground	

4.12 Fan connectors , FAN_CPU and FAN_SYS.

The **FAN_CPU** is used for connection of the active cooler for the CPU.

The **FAN_SYS** can be used to power, control and monitor a fan for chassis ventilation etc.

The 4pin header supports connection of 3-pin FANs, but it is recommended to use the 4-pin type for optimized FAN speed control. The 3- or 4-pin mode is controlled in the BIOS setup menu.

4-pin Mode:

PIN	Signal	Type	Ioh/Iol	Pull U/D	Note
1	CONTROL	O	-	-	
2	SENSE	I	-	4K7	
3	+12 V	PWR	-	-	
4	GND	PWR	-	-	

Signal description:

Signal	Description
CONTROL	PWM signal for FAN speed control
SENSE	Tacho signal from the fan for supervision. The signals shall be generated by an open collector transistor or similar. On board is a pull-up resistor 4K7 to +12V. The signal has to be pulses, typically 2 Hz per rotation.
12V	+12V supply for fan. A maximum of 2000 mA can be supplied from this pin.
GND	Power Supply GND signal

3-pin Mode:

PIN	Signal	Type	Ioh/Iol	Pull U/D	Note
-	-	-	-	-	
2	SENSE	I	-	4K7	
3	+12 V	PWR	-	-	
4	GND	PWR	-	-	

Signal description:

Signal	Description
SENSE	Tacho signal from the fan for supervision. The signals shall be generated by an open collector transistor or similar. On board is a pull-up resistor 4K7 to +12V. The signal has to be pulses, typically 2 Hz per rotation.
12V	+12V supply for fan, can be turned on/off or modulated (PWM) by the chipset. A maximum of 2000 mA can be supplied from this pin.
GND	Power Supply GND signal

4.13 The Clear CMOS Jumper, Clr-CMOS.

The Clr-CMOS Jumper is used to clear the CMOS content.

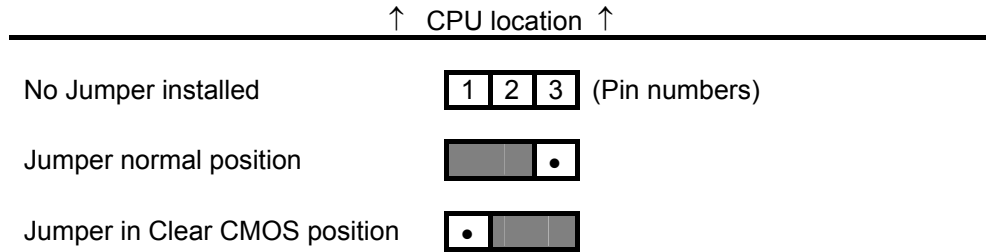

To clear all CMOS settings, including Password protection, move the CMOS_CLR jumper (with or without power on the system) for approximately 1 minute.

Alternatively if no jumper is available, turn off power and remove the battery for 1 minute, but be careful to orientate the battery correctly when reinserted.

4.14 TPM connector (unsupported).

Note	Pull U/D	Ioh/Iol	Type	Signal	PIN		Signal	Type	Ioh/Iol	Pull U/D	Note
	-	-	PWR	LPC CLK	1	2	GND				
	-	-	PWR	LPC FRAME#	3		KEY				
				LPC RST#	5	6	+5V				
				LPC AD3	7	8	LPC AD2				
				+3V3	9	10	LPC AD1				
				LPC AD0	11	12	GND				
				SMB_CLK	13	14	SMB_DATA				
				SB3V3	15	16	LPC SERIRQ				
				GND	17	18	CLKRUN#				
				SUS_STAT#	19	20	LPC IRQ#				

4.15 SPI connector (unsupported).

Note	Pull U/D	Ioh/Iol	Type	Signal	PIN		Signal	Type	Ioh/Iol	Pull U/D	Note
				SPI_CLK	1	2	SB3V3				
	10K/			NC	3	4	BOOT0				
	10K/			SPI_CS1#	5	6	BOOT1				
	10K/			SPI_MOSI	7	8	MFG				
	10K/			SPI_MISO	9	10	GND				

4.16 Front Panel connector (FRONTPNL).

Note	Pull U/D	Ioh/Iol	Type	Signal	PIN		Signal	Type	Ioh/Iol	Pull U/D	Note
				USB13_5V	1	2	USB13_5V				
				USB1-	3	4	USB3-				
				USB1+	5	6	USB3+				
	-	-	PWR	GND	7	8	GND	PWR	-	-	
	-	-	-	NC	9	10	LINE2-IN-L	-	-	-	
	-	-	PWR	+5V	11	12	+5V	PWR	-	-	
			OC	HD_LED	13	14	SUS_LED				
	-	-	PWR	GND	15	16	PWRBTN_IN#				
				RSTIN#	17	18	GND	PWR	-	-	
				SB3V3	19	20	LINE2-IN-R	-	-	-	
				AGND	21	22	AGND				
1				MIC2-L	23	24	MIC2-R				1

Note 1: Unsupported inputs, leave these inputs unconnected.

Signal	Description
USB13_5V	+5V supply for the USB devices on USB Port 1 and 3 is on-board fused with a 1.5A reset-able fuse. The supply is common for the two channels. SB5V is supplied during power down to allow wakeup on USB device activity.
USB1+ USB1-	Universal Serial Bus Port 1 Differentials: Bus Data/Address/Command Bus.
USB3+ USB3-	Universal Serial Bus Port 3 Differentials: Bus Data/Address/Command Bus.
+5V	Maximum load is 1A or 2A per pin if using IDC connector/fladkabel or crimp terminals respectively.
HD_LED	Hard Disk Activity LED (active low signal). Output is via 475Ω to OC.
SUS_LED	Suspend Mode LED (active high signal). Output is via 475Ω.
PWRBTN_IN#	Power Button In. Toggle this signal low to start the ATX / BTX PSU and boot the board.
RSTIN#	Reset Input. When pulled low for minimum 16mS the reset process will be initiated. The reset process continues even though the Reset Input is kept low.
LINE2-IN	Line in 2 signals
MIC2	MIC2-L and MIC2-R are unsupported. Leave these terminals unconnected.
SB3V3	Standby 3.3V voltage
AGND	Analogue Ground for Audio

4.17 Feature Connector (FEATURE)

Note	Pull U/D	Ioh/Iol	Type	Signal	PIN		Signal	Type	Ioh/Iol	Pull U/D	Note
2	243K/	-	I	INTRUDER#	1	2	GND	PWR	-	-	
				EXT_ISAIRQ#	3	4	EXT_SMI#	I			
				PWR_OK	5	6	SB5V	PWR	-	-	
	-	-	PWR	SB3V3	7	8	EXT_BAT	PWR	-	-	
	-	-	PWR	+5V	9	10	GND	PWR	-	-	
1	2K7/	/12mA	IOT	GPIO0	11	12	GPIO1	IOT	/12mA	2K7/	1
1	2K7/	/12mA	IOT	GPIO2	13	14	GPIO3	IOT	/12mA	2K7/	1
1	2K7/	/12mA	IOT	GPIO4	15	16	GPIO5	IOT	/12mA	2K7/	3
3	2K7/	/12mA	IOT	GPIO6	17	18	GPIO7	IOT	/12mA	2K7/	3
	-	-	PWR	GND	19	20	FAN3OUT				
				FAN3IN	21	22	+12V	PWR	-	-	
				TEMP3IN	23	24	VREF				
	-	-	PWR	GND	25	26	IRRX				
				IRTX	27	28	GND	PWR	-	-	
1	2K7/			SMBC	29	30	SMBD			2K7/	1

Note 1: Pull-up to +3V3Dual (+3V3 or SB3V3). Note 2: Pull-up to RTC-Voltage. Note 3: Pull-up to +3V3.

Signal	Description
INTRUDER#	INTRUDER, may be used to detect if the system case has been opened. This signal's status is readable, so it may be used like a GPI when the Intruder switch is not needed.
EXT_ISAIRQ#	EXtERnal ISA IRQ, (active low input) can activate standard AT-Bus IRQ-interrupt.
EXT_SMI#	External SMI, (active low input) signal can activate SMI interrupt.
PWR_OK	PoWeR OK, signal is high if no power failures is detected.
SB5V	StandBy +5V supply.
SB3V3	Max. load is 0.75A (1.5A < 1 sec.)
EXT_BAT	(EXtERnal BATtery) the + terminal of an external primary cell battery can be connected to this pin. The – terminal of the battery shall be connected to GND (etc. pin 10). The external battery is protected against charging and can be used with or without the on board battery installed. The external battery voltage shall be in the range: 2.5 - 4.0 V DC. Current draw is 3µA when PSU is disconnected.
+5V	Max. load is 0.75A (1.5A < 1 sec.)
GPIO0..7	General Purpose Inputs / Output. These Signals may be controlled or monitored through the use of the KONTRON API (Application Programming Interface) available for WinXP and Win2000.
FAN3OUT	FAN 3 speed control OUTput. This analogue voltage output signal can be set to output voltages from 0 – 3V3 to control the Fan's speed.. For more information please look into the datasheet for the Winbond I/O controller W83627.
FAN3IN	FAN3 Input. 0V to +3V3 amplitude Fan 3 tachometer input.
+12V	Max. load is 0.75A (1.5A < 1 sec.)
TEMP3IN	Temperature sensor 3 input. (Recommended: Transistor 2N3904, having emitter connected to GND (pin 25), collector and basis shorted and connected to pin23 (Temp3-In). Further a resistor 30K/1% shall be connected between pin 23 and pin 24 (Vref). (Precision +/- 3°C)
VREF	Voltage REFERENCE, reference voltage to be used with TEMP3IN input.
IRRX	IR Receive input (IrDA 1.0, SIR up to 1.152K bps)
IRTX	IR Transmit output (IrDA 1.0, SIR up to 1.152K bps)
SMBC	SMBus Clock signal
SMBD	SMBus Data signal

4.18 PCI Slot Connector

Note	Type	Signal	Terminal		Signal	Type	Note
			S	C			
	PWR	-12V	F01	E01	TRST#	O	
	O	TCK	F02	E02	+12V	PWR	
	PWR	GND	F03	E03	TMS	O	
	I	TDO	F04	E04	TDI	O	
	PWR	+5V	F05	E05	+5V	PWR	
	PWR	+5V	F06	E06	INTA#	I	
	I	INTB#	F07	E07	INTC#	I	
	I	INTD#	F08	E08	+5V	PWR	
	I	REQ2#	F09	E09	CLKC	O	
	I	REQ3#	F10	E10	+5V (I/O)	PWR	
	OT	GNT2#	F11	E11	CLKD	O	
	PWR	GND	F12	E12	GND	PWR	
	PWR	GND	F13	E13	GND	PWR	
	O	CLKA	F14	E14	GNT3#	OT	
	PWR	GND	F15	E15	RST#	O	
	O	CLKB	F16	E16	+5V (I/O)	PWR	
	PWR	GND	F17	E17	GNT0#	OT	
	I	REQ0#	F18	E18	GND	PWR	
	PWR	+5V (I/O)	F19	E19	REQ1#	I	
	IOT	AD31	F20	E20	AD30	IOT	
	IOT	AD29	F21	E21	+3.3V	PWR	
	PWR	GND	F22	E22	AD28	IOT	
	IOT	AD27	F23	E23	AD26	IOT	
	IOT	AD25	F24	E24	GND	PWR	
	PWR	+3.3V	F25	E25	AD24	IOT	
	IOT	C/BE3#	F26	E26	GNT1#	OT	
	IOT	AD23	F27	E27	+3.3V	PWR	
	PWR	GND	F28	E28	AD22	IOT	
	IOT	AD21	F29	E29	AD20	IOT	
	IOT	AD19	F30	E30	GND	PWR	
	PWR	+3.3V	F31	E31	AD18	IOT	
	IOT	AD17	F32	E32	AD16	IOT	
	IOT	C/BE2#	F33	E33	+3.3V	PWR	
	PWR	GND	F34	E34	FRAME#	IOT	
	IOT	IRDY#	F35	E35	GND	PWR	
	PWR	+3.3V	F36	E36	TRDY#	IOT	
	IOT	DEVSEL#	F37	E37	GND	PWR	
	PWR	GND	F38	E38	STOP#	IOT	
	IOT	LOCK#	F39	E39	+3.3V	PWR	
	IOT	PERR#	F40	E40	SDONE	IO	
	PWR	+3.3V	F41	E41	SB0#	IO	
	IOC	SERR#	F42	E42	GND	PWR	
	PWR	+3.3V	F43	E43	PAR	IOT	
	IOT	C/BE1#	F44	E44	AD15	IOT	
	IOT	AD14	F45	E45	+3.3V	PWR	
	PWR	GND	F46	E46	AD13	IOT	
	IOT	AD12	F47	E47	AD11	IOT	
	IOT	AD10	F48	E48	GND	PWR	
	PWR	GND	F49	E49	AD09	IOT	
SOLDER SIDE				COMPONENT SIDE			
	IOT	AD08	F52	E52	C/BE0#	IOT	
	IOT	AD07	F53	E53	+3.3V	PWR	
	PWR	+3.3V	F54	E54	AD06	IOT	
	IOT	AD05	F55	E55	AD04	IOT	
	IOT	AD03	F56	E56	GND	PWR	
	PWR	GND	F57	E57	AD02	IOT	
	IOT	AD01	F58	E58	AD00	IOT	
	PWR	+5V (I/O)	F59	E59	+5V (I/O)	PWR	
	IOT	ACK64#	F60	E60	REQ64#	IOT	
	PWR	+5V	F61	E61	+5V	PWR	
	PWR	+5V	F62	E62	+5V	PWR	

4.18.1 Signal Description –PCI Slot Connector

SYSTEM PINS	
CLK	Clock provides timing for all transactions on PCI and is an input to every PCI device. All other PCI signals, except RST#, INTA#, INTB#, INTC#, and INTD#, are sampled on the rising edge of CLK and all other timing parameters are defined with respect to this edge. PCI operates at 33 MHz.
RST#	Reset is used to bring PCI-specific registers, sequencers, and signals to a consistent state. What effect RST# has on a device beyond the PCI sequencer is beyond the scope of this specification, except for reset states of required PCI configuration registers. Anytime RST# is asserted, all PCI output signals must be driven to their benign state. In general, this means they must be asynchronously tri-stated. SERR# (open drain) is floated. REQ# and GNT# must both be tri-stated (they cannot be driven low or high during reset). To prevent AD, C/BE#, and PAR signals from floating during reset, the central resource may drive these lines during reset (bus parking) but only to a logic low level—they may not be driven high. RST# may be asynchronous to CLK when asserted or deasserted. Although asynchronous, deassertion is guaranteed to be a clean, bounce-free edge. Except for configuration accesses, only devices that are required to boot the system will respond after reset.
ADDRESS AND DATA	
AD[31::00]	Address and Data are multiplexed on the same PCI pins. A bus transaction consists of an address phase followed by one or more data phases. PCI supports both read and write bursts. The address phase is the clock cycle in which FRAME# is asserted. During the address phase AD[31::00] contain a physical address (32 bits). For I/O, this is a byte address; for configuration and memory, it is a DWORD address. During data phases AD[07::00] contain the least significant byte (lsb) and AD[31::24] contain the most significant byte (msb). Write data is stable and valid when IRDY# is asserted and read data is stable and valid when TRDY# is asserted. Data is transferred during those clocks where both IRDY# and TRDY# are asserted.
C/BE[3::0]#	Bus Command and Byte Enables are multiplexed on the same PCI pins. During the address phase of a transaction, C/BE[3::0]# define the bus command. During the data phase C/BE[3::0]# are used as Byte Enables. The Byte Enables are valid for the entire data phase and determine which byte lanes carry meaningful data. C/BE[0]# applies to byte 0 (lsb) and C/BE[3]# applies to byte 3 (msb).
PAR	Parity is even parity across AD[31::00] and C/BE[3::0]#. Parity generation is required by all PCI agents. PAR is stable and valid one clock after the address phase. For data phases, PAR is stable and valid one clock after either IRDY# is asserted on a write transaction or TRDY# is asserted on a read transaction. Once PAR is valid, it remains valid until one clock after the completion of the current data phase. (PAR has the same timing as AD[31::00], but it is delayed by one clock.) The master drives PAR for address and write data phases; the target drives PAR for read data phases.
INTERFACE CONTROL PINS	
FRAME#	Cycle Frame is driven by the current master to indicate the beginning and duration of an access. FRAME# is asserted to indicate a bus transaction is beginning. While FRAME# is asserted, data transfers continue. When FRAME# is deasserted, the transaction is in the final data phase or has completed.
IRDY#	Initiator Ready indicates the initiating agent's (bus master's) ability to complete the current data phase of the transaction. IRDY# is used in conjunction with TRDY#. A data phase is completed on any clock both IRDY# and TRDY# are sampled asserted. During a write, IRDY# indicates that valid data is present on AD[31::00]. During a read, it indicates the master is prepared to accept data. Wait cycles are inserted until both IRDY# and TRDY# are asserted together.
TRDY#	Target Ready indicates the target agent's (selected device's) ability to complete the current data phase of the transaction. TRDY# is used in conjunction with IRDY#. A data phase is completed on any clock both TRDY# and IRDY# are sampled asserted. During a read, TRDY# indicates that valid data is present on AD[31::00]. During a write, it indicates the target is prepared to accept data. Wait cycles are inserted until both IRDY# and TRDY# are asserted together.
STOP#	Stop indicates the current target is requesting the master to stop the current transaction.
LOCK#	Lock indicates an atomic operation that may require multiple transactions to complete. When LOCK# is asserted, non-exclusive transactions may proceed to an address that is not currently locked. A grant to start a transaction on PCI does not guarantee control of LOCK#. Control of LOCK# is obtained under its own protocol in conjunction with GNT#. It is possible for different agents to use PCI while a single master retains ownership of LOCK#. If a device implements Executable Memory, it should also implement LOCK# and guarantee complete access exclusion in that memory. A target of an access that supports LOCK# must provide exclusion to a minimum of 16 bytes (aligned). Host bridges that have system memory behind them should implement LOCK# as a target from the PCI bus point of view and optionally as a master.
IDSEL	Initialization Device Select is used as a chip select during configuration read and write transactions.
DEVSEL#	Device Select, when actively driven, indicates the driving device has decoded its address as the target of the current access. As an input, DEVSEL# indicates whether any device on the bus has been selected.

(continues)

ARBITRATION PINS (BUS MASTERS ONLY)	
REQ#	Request indicates to the arbiter that this agent desires use of the bus. This is a point to point signal. Every master has its own REQ# which must be tri-stated while RST# is asserted.
GNT#	Grant indicates to the agent that access to the bus has been granted. This is a point to point signal. Every master has its own GNT# which must be ignored while RST# is asserted.
	While RST# is asserted, the arbiter must ignore all REQ# lines since they are tri-stated and do not contain a valid request. The arbiter can only perform arbitration after RST# is deasserted. A master must ignore its GNT# while RST# is asserted. REQ# and GNT# are tri-state signals due to power sequencing requirements when 3.3V or 5.0V only add-in boards are used with add-in boards that use a universal I/O buffer.
ERROR REPORTING PINS.	
The error reporting pins are required by all devices and maybe asserted when enabled	
PERR#	Parity Error is only for the reporting of data parity errors during all PCI transactions except a Special Cycle. The PERR# pin is sustained tri-state and must be driven active by the agent receiving data two clocks following the data when a data parity error is detected. The minimum duration of PERR# is one clock for each data phase that a data parity error is detected. (If sequential data phases each have a data parity error, the PERR# signal will be asserted for more than a single clock.) PERR# must be driven high for one clock before being tri-stated as with all sustained tri-state signals. There are no special conditions when a data parity error may be lost or when reporting of an error may be delayed. An agent cannot report a PERR# until it has claimed the access by asserting DEVSEL# (for a target) and completed a data phase or is the master of the current transaction.
SERR#	System Error is for reporting address parity errors, data parity errors on the Special Cycle command, or any other system error where the result will be catastrophic. If an agent does not want a non-maskable interrupt (NMI) to be generated, a different reporting mechanism is required. SERR# is pure open drain and is actively driven for a single PCI clock by the agent reporting the error. The assertion of SERR# is synchronous to the clock and meets the setup and hold times of all bused signals. However, the restoring of SERR# to the deasserted state is accomplished by a weak pullup (same value as used for s/t/s) which is provided by the system designer and not by the $\bar{\text{I}}$ signaling agent or central resource. This pull-up may take two to three clock periods to fully restore SERR#. The agent that reports SERR#s to the operating system does so anytime SERR# is sampled asserted.
INTERRUPT PINS (OPTIONAL).	
Interrupts on PCI are optional and defined as "level sensitive," asserted low (negative true), using open drain output drivers. The assertion and deassertion of INTx# is asynchronous to CLK. A device asserts its INTx# line when requesting attention from its device driver. Once the INTx# signal is asserted, it remains asserted until the device driver clears the pending request. When the request is cleared, the device deasserts its INTx# signal. PCI defines one interrupt line for a single function device and up to four interrupt lines for a multi-function device or connector. For a single function device, only INTA# may be used while the other three interrupt lines have no meaning.	
INTA#	Interrupt A is used to request an interrupt.
INTB#	Interrupt B is used to request an interrupt and only has meaning on a multi-function device.
INTC#	Interrupt C is used to request an interrupt and only has meaning on a multi-function device.
INTD#	Interrupt D is used to request an interrupt and only has meaning on a multi-function device.

4.18.2 KT965 PCI IRQ & INT routing

Board type	Slot	IDSEL	INTA	INTB	INTC	INTD
KT965/FLEX	1	AD16	INT_PIRQ#A	INT_PIRQ#B	INT_PIRQ#C	INT_PIRQ#D
	2	AD17	INT_PIRQ#E	INT_PIRQ#F	INT_PIRQ#G	INT_PIRQ#H
KT965/ATXP	1	AD16	INT_PIRQ#A	INT_PIRQ#B	INT_PIRQ#C	INT_PIRQ#D
	2	AD17	INT_PIRQ#E	INT_PIRQ#F	INT_PIRQ#G	INT_PIRQ#H
	3	AD18	INT_PIRQ#F	INT_PIRQ#G	INT_PIRQ#H	INT_PIRQ#E
	4	AD19	INT_PIRQ#G	INT_PIRQ#H	INT_PIRQ#E	INT_PIRQ#F
	5	AD20	INT_PIRQ#H	INT_PIRQ#E	INT_PIRQ#F	INT_PIRQ#G
	6	AD21	INT_PIRQ#B	INT_PIRQ#C	INT_PIRQ#D	INT_PIRQ#A
KT965/ATXE	1	AD16	INT_PIRQ#A	INT_PIRQ#B	INT_PIRQ#C	INT_PIRQ#D
	2	AD17	INT_PIRQ#E	INT_PIRQ#F	INT_PIRQ#G	INT_PIRQ#H
	3	AD18	INT_PIRQ#F	INT_PIRQ#G	INT_PIRQ#H	INT_PIRQ#E
	4	AD19	INT_PIRQ#G	INT_PIRQ#H	INT_PIRQ#E	INT_PIRQ#F
	5	AD20	INT_PIRQ#H	INT_PIRQ#E	INT_PIRQ#F	INT_PIRQ#G

When using the 820982 "PCI Riser - Flex - 2slot w. arbiter" the lower slot has IDSEL / IRQs routed straight through and the top slot has the routing: IDSEL=AD30, INT_PIRQ#D, INT_PIRQ#A, INT_PIRQ#B, INT_PIRQ#C. 820982 PCI Riser shall be plugged into Slot #1.

5. Onboard Connectors

Connector	Onboard Connectors		Mating Connectors	
	Manufacturer	Type no.	Manufacturer	Type no.
FAN_SYS,	Foxconn	HF2704E-M1	AMP	1375820-4 (4-pole)
FAN_CPU	AMP	1470947-1	AMP	1375820-3 (3-pole)
KBDMSE	Molex	22-23-2061	Molex	22-01-2065
CDROM	Foxconn	HF1104E	Molex	50-57-9404
	Molex	70543-0038		
SATA0-5	Molex	67491-0020	Molex	67489-8005
			Kontron	KT 821035 (cable kit)
ATXPWR	Molex	44-206-0002	Molex	39-01-2245 (24-pole)
			Molex	39-01-2205 (20-pole)
COM2	Foxconn	HL20051	Molex	90635-1103
			Kontron	KT 821016 (cable kit)
			Kontron	KT 821017 (cable kit)
USB1 USB3 (*)	(FRONTPNL)	-	Kontron	KT 821401 (cable kit)
PRINTER	Foxconn	HL2213F	Molex	90635-1263
			Kontron	KT 821031 (cable kit)
AUDIO_HEAD	Molex	87831-2620	Molex	51110-2651
			Kontron	KT 821043 (cable kit)
FRONTPNL	Foxconn	HL20121	Molex	90635-1243
			Kontron	KT 821042 (cable kit)
FEATURE	Molex	87831-3020	Molex	51110-3051
			Kontron	KT 821041 (cable kit)
LVDS (ADD2-LVDS card)	Don Connex	C44-40BSB1-G	Don Connex	A32-40-C-G-B-1
			Kontron	KT 821515 (cable kit)
			Kontron	KT 821155 (cable kit)

* USB1/USB3 are located in FRONTPNL connector. Depending on application the KT821401 can be used.

6. System Resources

6.1 Memory map

Address range (hex)	Size	Description
00000000 0009FFFF	640K	System board
000A0000 000BFFFF	128K	Intel 965 Express Chipset Family
000A0000 000BFFFF	128K	PCI bus
000C0000 000CFFFF	128K	System board
000D0000 000DFFFF	65K	PCI bus
000E0000 000FFFFF	128K	System board
00100000 1F7FFFFF	503M	System board
1F800000 FFFFFFFF	3592M	PCI bus
D0000000 DFFFFFFF	256M	Intel 965 Express Chipset Family
E0000000 EFFFFFFF	256M	Motherboards resources
FEC00000 FEC00FFF	4K	Motherboards resources
FED14000 FED19FFF	20K	System board
FED1C000 FED1FFFF	16K	Motherboards resources
FED20000 FED8FFFF	384K	Motherboards resources
FEE00000 FEE00FFF	4K	Motherboards resources
FF600000 FF6FFFFF	1M	Intel ICH8 Family PCI Express Root Port
FF6FF000 FF6FFFFF	4096	Realtek RTL8111b PCI-E Gigabit Ethernet NIC
FF700000 FF7FFFFF	1M	Intel ICH8 Family PCI Express Root Port
FF7FF000 FF7FFFFF	4096	Realtek RTL8111b PCI-E Gigabit Ethernet NIC
FF9F4000 FF9F7FFF	16K	Microsoft UAA Bus Driver for High Definition Audio
FF9FB400 FF9FB4FF	256	Intel ICH8 Family SMBUS Controller
FF9FB800 FF9FBBFF	1K	Intel ICH8 Family USB2 Enhanced Host Controller
FF9FBC00 FF9FBFFF	1K	Intel ICH8 Family USB2 Enhanced Host Controller
FFA00000 FFAFFFFFFF	1M	Mobile Intel 965 Express Chipset Family
FFB00000 FFBFFFFFFF	1M	Intel 82802 Firmware Hub Device
FFC00000 FFEFFFFFFF	3M	Motherboard resources
FFF00000 FFFFFFFF	1M	Intel 82802 Firmware Hub Device

6.2 PCI devices

Bus #	Device #	Function #	Vendor ID	Device ID	IDSEL	Chip	Device Function
0	0	0	8086h	2990h		965	Host bridge
0	2	0	8086h	2992h		965	VGA controller
0	26	0	8086h	2834h		ICH8	USB
0	26	1	8086h	2835h		ICH8	USB
0	26	7	8086h	283Ah		ICH8	USB
0	27	0	8086h	284Bh		ICH8	HD-Audio
0	28	0	8086h	283Fh		ICH8	PCI 2 PCI Bridge
0	28	4	8086h	2847h		ICH8	PCI 2 PCI Bridge
0	28	5	8086h	2849h		ICH8	PCI 2 PCI Bridge
0	29	0	8086h	2830h		ICH8	USB
0	29	1	8086h	2831h		ICH8	USB
0	29	2	8086h	2832h		ICH8	USB
0	29	7	8086h	2836h		ICH8	USB
0	30	0	8086h	244Eh		ICH8	PCI 2 PCI Bridge
0	31	0	8086h	2814h		ICH8	ISA Bridge
0	31	2	8086h	2820h		ICH8	IDE Controller
0	31	3	8086h	283Eh		ICH8	SMBUS Controller
0	31	5	8086h	2825h		ICH8	IDE Controller
2	0	0	10ECh	8168h		RTL8111b	Ethernet
3	0	0	10ECh	8168h		RTL8111b	Ethernet
4	0	0	-	-	AD16	-	PCI slot #1
4	1	0	-	-	AD17	-	PCI slot #2
*	-	-	-	-	-	-	PCI-E slot
*	-	-	-	-	-	-	Mini PCI-E slot #1

When a PCI-E or Mini PCI-E card is used it could change the BUS number on other PCI-E and PCI devices like RTL8111b.

Note: All PCI slots for the KT965 boards supports PCI BUS Mastering.

6.3 Interrupt Usage

IRQ	Onboard system parity errors and IOCHCHK signal activation	Onboard Timer 0 Interrupt	Onboard Keyboard Interrupt	Used for Cascading IRQ8-IRQ15	May be used by onboard Serial Port A	May be used by onboard Serial Port B / IrDA Port	May be used by onboard Parallel Port	Used by onboard Real Time Clock Alarm	May be used by onboard P/S 2 support	Used for Onboard co-processor support	May be used for SATA RAID controller	May be used for onboard Sound System	May be used for PCI Express Root Port	May be used by onboard USB controller	May be used by onboard Ethernet controller 1	May be used by onboard Ethernet controller 2	May be used by onboard VGA Controller	May be used by onboard SMBus Controller	Available on PCI slots as IRQA-IRQD depending on selections in the BIOS	Notes
NMI	•																			
IRQ0		•																		
IRQ1			•																	
IRQ2				•																
IRQ3						•														1, 2
IRQ4					•															1, 2
IRQ5														•				•		1, 2
IRQ6																				1, 2
IRQ7							•							•						1, 2
IRQ8								•												
IRQ9																			•	1, 2
IRQ10													•						•	1, 2
IRQ11												•		•	•				•	1, 2
IRQ12									•					•						1
IRQ13										•										
IRQ14																				1
IRQ15																				1
IRQ16																				3
IRQ17																				3
IRQ18																				3
IRQ19											•									3
IRQ20																				3
IRQ21																				3
IRQ22																				3
IRQ23																				3
IRQ24																				3
IRQ25																				3
IRQ26																				3

Notes:

1. Availability of the shaded IRQs depends on the setting in the BIOS. According to the PCI Standard, PCI Interrupts IRQA-IRQD can be shared.
2. These interrupt lines are managed by the PnP handler and are subject to change during system initialisation.
3. IRQ16 to IRQ26 are APIC interrupts

6.4 I/O Map

Address (hex)	Size	Description
0020- 0021	1	Programmable interrupt controller
0040- 0043	4	System Timer
0060- 0060	1	Standard keyboard
0061- 0061	1	System speaker
0064- 0064	1	Standard keyboard
0070- 0071	2	System CMOS/Real time clock
0170- 01F7	8	Secondary Parallel ATA IDE Channel
01F0- 01F7	8	Primary Parallel ATA IDE Channel
02F8- 02FF	8	Comport 2 / IRDA
0376- 0376	1	Secondary IDE Channel
0378- 037F	8	Printer Port
03B0- 03BB	12	Intel 965 Express Chipset Family
03C0- 03DF	32	Intel 965 Express Chipset Family
03F6- 03F6	1	Primary IDE Channel
03F8- 03FF	8	Comport 1
0400- 041F	32	SMBus Controller
0480- 04BF	64	Motherboard resources
04D0- 04D1	2	Motherboard resources
0800- 087F	128	Motherboard resources
0A00- 0A0F	16	Motherboard resources
0A10- 0A1F	16	Motherboard resources
0A79- 0A79	256	PNP port
B000- BFFF	4K	PCI Express Root Port
B800- B8FF	256	RTL8111b PCI-E Gigabit Ethernet NIC
C000- CFFF	4K	PCI Express Root Port
C800- C8FF	256	RTL8111b PCI-E Gigabit Ethernet NIC
D400- D41F	32	Intel ICH8 Family USB Host Controller
D480- D49F	32	Intel ICH8 Family USB Host Controller
D800- D81F	32	Intel ICH8 Family USB Host Controller
D880- D89F	32	Intel ICH8 Family USB Host Controller
DC00- DC1F	32	Intel ICH8 Family USB Host Controller
E000- E00F	16	Intel ICH8 Family Serial ATA Storage Controller
E080- E08F	16	Intel ICH8 Family Serial ATA Storage Controller
E400- E403	4	Intel ICH8 Family Serial ATA Storage Controller
E480- E487	8	Intel ICH8 Family Serial ATA Storage Controller
E800- E803	8	Intel ICH8 Family Serial ATA Storage Controller
E880- E887	8	Intel ICH8 Family Serial ATA Storage Controller
EC00- EC07	8	965 VGA Controller
FF90- FF9F	16	Intel ICH8 Family Serial ATA Storage Controller
FFA0- FFAF	16	Intel ICH8 Family Serial ATA Storage Controller

Notes: This is the IO map after a standard Windows XP SP2 installation

6.5 DMA Channel Usage

DMA Channel Number	Data Width	System Resources
0	8 or 16 bits	Available
1	8 or 16 bits	Available
2	8 or 16 bits	Available
3	8 or 16 bits	Available
4	8 or 16 bits	DMA Controller
5	16 bits	Available
6	16 bits	Available
7	16 bits	Available

7. Overview of BIOS features

This Manual section details specific BIOS features for the KT965 boards.

The KT965 boards are based on the AMI BIOS core version 8.10 with Kontron BIOS extensions.

7.1 System Management BIOS (SMBIOS / DMI)

SMBIOS is a Desktop Management Interface (DMI) compliant method for managing computers in a managed network.

The main component of SMBIOS is the Management Information Format (MIF) database, which contains information about the computing system and its components. Using SMBIOS, a system administrator can obtain the system types, capabilities, operational status, and installation dates for system components.

The MIF database defines the data and provides the method for accessing this information. The BIOS enables applications such as third-party management software to use SMBIOS.

The BIOS stores and reports the following SMBIOS information:

- BIOS data, such as the BIOS revision level
- Fixed-system data, such as peripherals, serial numbers, and asset tags
- Resource data, such as memory size, cache size, and processor speed
- Dynamic data, such as event detection and error logging

Non-Plug and Play operating systems, such as Windows NT*, require an additional interface for obtaining the SMBIOS information. The BIOS supports an SMBIOS table interface for such operating systems. Using this support, an SMBIOS service-level application running on a non-Plug and Play operating system can obtain the SMBIOS information.

7.2 Legacy USB Support

Legacy USB support enables USB devices such as keyboards, mice, and hubs to be used even when the operating system's USB drivers are not yet available. Legacy USB support is used to access the BIOS Setup program, and to install an operating system that supports USB. By default, Legacy USB support is set to Enabled.

Legacy USB support operates as follows:

1. When you apply power to the computer, legacy support is disabled.
2. POST begins.
3. Legacy USB support is enabled by the BIOS allowing you to use a USB keyboard to enter and configure the BIOS Setup program and the maintenance menu.
4. POST completes.
5. The operating system loads. While the operating system is loading, USB keyboards and mice are recognized and may be used to configure the operating system. (Keyboards and mice are not recognized during this period if Legacy USB support was set to Disabled in the BIOS Setup program.)
6. After the operating system loads the USB drivers, all legacy and non-legacy USB devices are recognized by the operating system, and Legacy USB support from the BIOS is no longer used.

To install an operating system that supports USB, verify that Legacy USB support in the BIOS Setup program is set to Enabled and follow the operating system's installation instructions.

8. BIOS Configuration / Setup

8.1 Introduction

The BIOS Setup is used to view and configure BIOS settings for the KT965 board. The BIOS Setup is accessed by pressing the DEL key after the Power-On Self-Test (POST) memory test begins and before the operating system boot begins. The Menu bar look like this:

BIOS SETUP UTILITY						
Main	Advanced	PCIPnP	Boot	Security	Chipset	Exit

The available keys for the Menu screens are:

- Select Menu: <←> or <→>
- Select Item: <↑> or <↓>
- Select Field: <Tab>
- Change Field: <+> or <->
- Help: <F1>
- Save and Exit: <F10>
- Exits the Menu: <Esc>

Please note that in the following the different BIOS Features will be described as having some options. These options will be selected automatically when loading either Failsafe Defaults or Optimal Defaults. The Default options will be indicated by the option in bold, but please notice that when Failsafe Defaults are loaded a few of the options, marked with "*", are now the default option.

8.2 Main Menu

BIOS SETUP UTILITY						
Main	Advanced	PCIPnP	Boot	Security	Chipset	Exit
System Overview AMIBIOS Version : 08.00.14 Build Date: 03/04/08 ID : KT965017 PCB ID : A1 Serial # : 00478603 Part # : 61310000 Processor Intel® Core (TM)2 CPU 6700 @ 2.66GHz Speed : 2666MHz Count : 1 System Memory Size : 1016MB System Time [10:18:15] System Date [10/19/2009]					Use [ENTER], [TAB] or [SHIFT-TAB] to select a field. Use [+] or [-] to configure system Time. <- Select Screen Select Item +- Change Field Tab Select Field F1 General Help F10 Save and Exit ESC Exit	
v02.59+ (C)Copyright 1985-2005, American Megatrends, Inc.						

Main Menu Selections

You can make the following selections. Use the sub menus for other selections.

Feature	Options	Description
System Time	HH:MM:SS	Set the system time.
System Date	MM/DD/YYYY	Set the system date.

8.3.1 Advanced settings – CPU Configuration

BIOS SETUP UTILITY	
Advanced	
Configure advanced CPU settings Module Version: 3F.07 Manufacturer: Intel Intel® Core (TM)2 CPU 6700 @ 2.66GHz Frequency : 2.66GHz FSB Speed : 1067MHz Cache L1 : 64 KB Cache L2 : 4096 KB Ratio Actual Value: 10 Max CPUID Value Limit [Disabled] Intel(R)Virtualization Tech [Enabled] Execute-Disable Bit Capability [Enabled] Core Multi-Processing [Enabled] Intel(R) SpeedStep(tm) tech. [Enabled]	Maximum: CPU Speed is set to maximum. Minimum: CPU Speed is set to minimum. Automatic: CPU speed controlled by Operating system. Disabled: Default CPU speed. <- Select Screen Select Item +- Change Option F1 General Help F10 Save and Exit ESC Exit
v02.59+ (C)Copyright 1985-2005, American Megatrends, Inc.	

Feature	Options	Description
Max CPUID Value Limit	Enabled Disabled	Disabled for WindowsXP
Intel ® Virtualization Tech	Enabled Disabled	Enabled it when the processor supported Virtualization Technology (Vanderpool technology).Need a full reset to change its state.
Execute Disable Bit Capability	Enabled Disabled	When disabled,force the XD feature flag to always return 0.
Core Multi-Processing	Enabled Disabled	When disabled, disable one execution core.
Intel™ SpeedStep™ tech.	Enabled Disabled *	When enabled Speedstep can be controlled via OS. When Disabled (Failsafe Default) the CPU speed will be Maximum Speed. (In order to verify the effect of the setting a reboot must be carried out).

8.3.2 Advanced settings – IDE Configuration

BIOS SETUP UTILITY		
Advanced		
IDE Configuration		Options
Sata#1 Configuration	[Compatible]	Disabled Compatible Enhanced
Configure SATA#1 as	[IDE]	
Sata#2 Configuration	[Enhanced]	
Primary IDE Master	: [Hard Disk]	
Secondary IDE Master	: [Not Detected]	
Third IDE Master	: [Not Detected]	
Third IDE Slave	: [Not Detected]	
Fourth IDE Master	: [Not Detected]	
Fourth IDE Slave	: [Not Detected]	
Hard Disk Write Protect	[Disabled]	
IDE Detect Time Out (Sec)	[35]	<- Select Screen
ATA(PI) 80Pin Cable Detection	[Host & Device]	Select Item
		+ - change option
		F1 General Help
		F10 Save and Exit
		ESC Exit
v02.59+ (C)Copyright 1985-2005, American Megatrends, Inc.		

Feature	Options	Description
SATA#1 Configuration	Disable Compatible Enhanced	Disable, Compatible Enhanced
Configure SATA#1 as	IDE Raid AHCI	IDE Raid AHCI
SATA#2 Configuration	Disabled Enhanced	Disabled Enhanced
<i>Primary IDE Master to Fourth IDE Slave see next page as example</i>		
Hard Disk Write Protect	Disable Enabled	Enable write protection on HDDs, only works when it is accessed through the BIOS
IDE Detect Time Out (Sec)	0, 5, 10, 15, 20, 25, 30, 35	Select the time out value when the BIOS is detecting ATA/ATAPI Devices
ATA(PI) 80Pin Cable Detection	Host & Device Host Device	Select the mechanism for detecting 80Pin ATA (PI) Cable

BIOS SETUP UTILITY	
Advanced	
Primary IDE Master Device :Hard Disk Vendor :ST340014A Size :40.0GB LBA Mode :Supported Block Mode :16Sectors PIO Mode :4 Async DMA :MultiWord DMA-2 Ultra DMA :Ultra DMA-5 S.M.A.R.T. :Supported	Select the type of devices connected to the system
Type [Auto] LBA/Large Mode [Auto] Block (Multi-Sector Transfer) [Auto] PIO Mode [Auto] DMA Mode [Auto] S.M.A.R.T. [Auto] 32Bit Data Transfer [Disabled]	<- Select Screen Select Item +- Change Option F1 General Help F10 Save and Exit ESC Exit
v02.59+ (C)Copyright 1985-2005, American Megatrends, Inc.	

Feature	Options	Description
Type	Not Installed Auto CDROM ARMD	Select the type of device installed
LBA/Large Mode	Disabled Auto	Enabling LBA causes Logical Block Addressing to be used in place of Cylinders, Heads, and Sectors.
Block (Multi-Sector Transfer)	Disabled Auto	Select if the device should run in Block mode
PIO Mode	Auto 0 1 2 3 4	Selects the method for transferring the data between the hard disk and system memory. The Setup menu only lists those options supported by the drive and platform.
DMA Mode	Auto , SWDMA0, SWDMA1, SWDMA2, MWDMA0, MWDMA1, MWDMA2, UDMA0, UDMA1, UDMA2, UDMA3, UDMA4, UDMA5	Selects the Ultra DMA mode used for moving data to/from the drive. Autotype the drive to select the optimum transfer mode. Note: To use UDMA Mode 2, 3, 4 and 5 with a device, the harddisk cable used MUST be UDMA66/100 cable (80-conductor cable).
S.M.A.R.T.	Auto Disabled Enabled	Select if the Device should be monitoring itself (Self-Monitoring, Analysis and Reporting Technology System)
32Bit Data Transfer	Disabled Enabled	Select if the Device should be using 32Bit data Transfer

8.3.3 Advanced settings – LAN Configuration

BIOS SETUP UTILITY	
Advanced	
LAN Configuration ETH1 Configuration (Right) [Enabled] MAC Address : 00E0F4000001 100MB* ETH2 Configuration (Left) [Enabled] MAC Address : 00E0F4000002 -	Control of Ethernet Devices and PXE boot <- Select Screen Select Item +- change option F1 General Help F10 Save and Exit ESC Exit
v02.59+ (C)Copyright 1985-2005, American Megatrends, Inc.	

* If link then speed is displayed (10Mb, 100Mb or 1000Mb)

Feature	Options	Description
ETH1 Configuration	Disabled Enabled With RPL/PXE boot	Select if you want to enable the LAN adapter, or if you want to activate the RPL/PXE boot rom
ETH2 Configuration	Disabled Enabled With RPL/PXE boot	Select if you want to enable the LAN adapter, or if you want to activate the RPL/PXE boot rom

Note: Wake On Lan is always supported in BIOS, but OS has to setup support for wake after Shutdown for relevant LAN port.

8.3.4 Advanced settings – Super IO Configuration

BIOS SETUP UTILITY	
Advanced	
Configure Win627DHG Super IO Chipset Serial Port1 Address [3F8/IRQ4] Serial Port2 Address [2F8/IRQ3] Serial Port2 Mode [Normal] Parallel Port Address [378] Parallel Port Mode [Normal] Parallel Port IRQ [IRQ7]	Allows BIOS to Select Serial Port1 Base Addresses. <- Select Screen Select Item +- change option F1 General Help F10 Save and Exit ESC Exit
v02.59+ (C)Copyright 1985-2005, American Megatrends, Inc.	

Feature	Options	Description
Serial Port1 Address	Disabled 3F8/IRQ4 3E8/IRQ4 3E8/IRQ6 3E8/IRQ10 2E8/IRQ11	Select the BASE I/O address and IRQ. (The available options depends on the setup for the the other Serial Ports).
Serial Port2 Address	Disabled 2F8/IRQ3 2E8/IRQ3 3E8/IRQ6 3E8/IRQ10 2E8/IRQ11	Select the BASE I/O address and IRQ. (The available options depends on the setup for the the other Serial Ports).
Serial Port2 Mode	Normal , IRDA, ASK IR	Select Mode for Serial Port2
Parallel Port Address	Disabled * 378 278 3BC	Select the I/O address for the PRINTER.
Parallel Port Mode	Normal , Bi-Directional, EPP, ECP & EEP	Select the mode that the parallel port will operate in
EPP Version	1.9 1.7	Setup with version of EPP you want to run on the parallel port
ECP Mode DMA Channel	DMA0, DMA1, DMA3	Select a DMA channel
Parallel Port IRQ	IRQ5, IRQ7	Select a IRQ

8.3.5 Advanced settings – Hardware Health Configuration

BIOS SETUP UTILITY	
Advanced	
Hardware Health Configuration	
System Temperature :37°C/98°F	Disable = Full Speed Thermal: Does regulate fan speed according to specified temperature
CPU Temperature :43°C/109°F	
SYSFAN Speed :Fail	Speed: Does regulate according to specified RPM <- Select Screen Select Item +- change option F1 General Help F10 Save and Exit ESC Exit
Fan Cruise Control [Disabled]	
Fan Type [4 Wire]	
CPUFAN00 Speed :2537 RPM	
Fan Cruise Control [Thermal]	
Fan Setting [45°C/113°F]	
Fan Type [4 Wire]	
AUXFAN Speed :2164	
Fan Cruise Control [Speed]	
Fan Setting [2177 RPM]	
Watchdog Function [Disabled]	
v02.59+ (C)Copyright 1985-2005, American Megatrends, Inc.	

Feature	Options	Description
Fan Cruise Control	Disabled Thermal Speed	Select how the Fan shall operate. When set to Thermal, the Fan will start to run at the CPU die temperature set below. When set to Speed, the Fan will run at the Fixed speed set below.
Fan Type	3 Wire 4 Wire	3 Wire: PWM Fan power line. (RPM reading at low speed might be poor). 4 Wire: Fixed 12V power line, PWM via control signal.
Fan Settings	1406-5625 RPM, 30°C/86°F to 60°C/140°F	The fan can operate in Thermal mode or in a fixed fan speed mode
Watchdog	Disabled , 15 seconds, 30 seconds, 1 minute, 2 minutes, 5 minutes, 10 minutes	To be service via API.

8.3.6 Advanced settings – Voltage Monitor

BIOS SETUP UTILITY	
Advanced	
Voltage Monitor	
Requested Core Vcore	:1.2750 V :1.248 V
AVCC	:3.232 V
3VCC	:3.232 V
+12Vin	:12.083 V
-12Vin	:Good
+5Vin	:5.165 V
Core 1.8 V	:1.808 V
Core 1.5 V	:1.496 V
VSB	:3.264 V
VBAT	:3.104 V
	Enable Hardware Health Monitoring Device. <- Select Screen Select Item +- change option F1 General Help F10 Save and Exit ESC Exit
v02.59+ (C)Copyright 1985-2005, American Megatrends, Inc.	

8.3.7 Advanced settings – ACPI Configuration

BIOS SETUP UTILITY	
Advanced	
ACPI Settings ACPI Version Features [V1.0] Repost Video on S3 Resume [No] PS/2 Kbd/Mouse S4/S5 Wake [Disabled] Keyboard Wake Hotkey [Any key] USB Device Wakeup From S3/S4 [Disabled]	Enable RSDP pointers To 64-bit Fixed System Description Tabled. Different ACPI version has some addition. <- Select Screen Select Item +- change option F1 General Help F10 Save and Exit ESC Exit
v02.59+ (C)Copyright 1985-2005, American Megatrends, Inc.	

Feature	Options	Description
ACPI Version Features	V1.0 V2.0 V3.0	Enable RSDP pointers to 64-bit Fixed System Description Tables. Different ACPI version has some addition.
Repost Video on S3 Resume	No Yes	Determines whether to invoke VGA BIOS post on S3/STR resume
PS/2 Kbd/Mouse S4/S5 Wake	Disabled Enabled	Enabled: System can be waked from S4 or S5. Disabled: PS2 Kbd/Mse can still wake system from S3.
Keyboard Wake Hotkey	Any Key "SPACE" "ENTER" "Sleep button"	Any Key "SPACE" "ENTER" "Sleep button"
USB Device Wakeup From S3/S4	Disabled Enabled	Enable/Disable USB Device Wakeup From S3/S4. (Note on XP, see below).

Note on XP: Windows XP do not support USB wake from S3/S4, but a fix is executing (from a bat file etc.):
 reg ADD HKLM\SYSTEM\CurrentControlSet\Services\usb /v USBBIOSx /t REG_DWORD /d 00000000 /f

8.3.8 Advanced settings – APM Configuration

BIOS SETUP UTILITY	
Advanced	
APM Configuration	Enable or disable APM.
Power Management/APM [Enabled]	
Advanced Resume Event Controls	
Resume On Ring [Disabled]	
Resume On PME# [Disabled]	
Resume On RTC Alarm [Disabled]	
	<- Select Screen Select Item +- change option F1 General Help F10 Save and Exit ESC Exit
v02.59+ (C)Copyright 1985-2005, American Megatrends, Inc.	

Feature	Options	Description
Power Management/APM	Enabled Disabled	Enable APM Disable APM
Resume On Ring	Disabled Enabled	Enable RI signal to generate wake event
Resume On PME#	Disabled Enabled	Disabled/Enable PME to generate a wake event. See note below.
Resume On RTC Alarm	Disabled Enabled	Disabled/Enable RTC to generate a wake event.
RTC Alarm Date (Days)	15	Key In "+" / "-" to select.
RTC Alarm Time	12:30:30	Use [ENTER], [TAB] or [SHIFT-TAB] to select a field. Use [+] or [-] to configure system Time.

Note on "Resume On PME#" (When using PCI LAN WOL function):

BIOS version must be KT965009 or higher. The LAN card must have a Standby Voltage input to make it possible to implement WOL. Very often such cards have a 3 pin connector and one of the pins is the Standby Voltage. This voltage can be taken directly from the ATX power supply or from the Front Panel connector pin 1 (or pin 2) or from the Feature connector pin 6. The LAN card must be setup in OS to support wake after Shutdown.

8.3.9 PCI Express Configuration

BIOS SETUP UTILITY	
Advanced	
PCI Express Configuration Active State Power-Management [Disabled]	Enable/Disable PCI Express L0s and L1 link power states. <- Select Screen Select Item +- change option F1 General Help F10 Save and Exit ESC Exit
v02.59+ (C)Copyright 1985-2005, American Megatrends, Inc.	

Feature	Options	Description
Active State Power-Management	Disabled Enabled	Enable/Disable PCI Express L0s and L1 link power states.

8.3.10 Advanced settings – Remote Access Configuration

BIOS SETUP UTILITY	
Advanced	
Configure Remote Access type and parameters Remote Access [Enabled] Serial port number [COM1] Base Address, IRQ [3F8h, 4] Serial Port Mode [115200 8,n,1] Flow Control [None] Redirection After BIOS POST [Always] Terminal Type [ANSI]	Select Remote Access type. <- Select Screen Select Item +- change option F1 General Help F10 Save and Exit ESC Exit
v02.59+ (C)Copyright 1985-2005, American Megatrends, Inc.	

Feature	Options	Description
Remote Access	Disabled Enabled	When Enabled then a remote PC can via one of the serial ports behave like a TTY terminal, so that keyboard and monitor (in a terminal window) is emulated by the remote PC. As remote PC terminal program the Windows Hyperterminal can be used.
Serial port number	COM1 COM2	Setup which comport that should be used for communication
Serial Port Mode	115200 8 n 1 57600 8 n 1 38400 8 n 1 19200 8 n 1 9600 8 n 1	Select the serial port speed
Flow Control	None Hardware Software	Select Flow Control for serial port
Redirection After BIOS POST	Disabled Boot Loader Always	How long shall the BIOS send the picture over the serial port
Terminal Type	ANSI VT100 VT-UTF8	Select the target terminal type

8.3.11 Advanced settings – TCG/TPM support

BIOS SETUP UTILITY	
Advanced	
Trusted Computing TCG/TPM SUPPORT [Yes] Execute TPM Command [Don't change] Clearing the TPM [Press Enter] TPM Enable/Disable Status [No State] TPM Owner Status [No State]	Enable/Disable TPM TCG (TPM 1.1/1.2) support in BIOS <- Select Screen Select Item +- change option F1 General Help F10 Save and Exit ESC Exit
v02.59+ (C)Copyright 1985-2005, American Megatrends, Inc.	

Feature	Options	Description
TCG/TPM SUPORT	No Yes	When "Yes" enabled the TPM TCG (TPM 1.1/1.2) support in BIOS.
Execute TPM Command	Don't change Disabled Enabled	Use Enabled/Disabled followed by reboot to Activate/Deactivate Command to TPM. (The below function: "Clearing the TPM")
Clearing the TPM (only visible if above is set to Enabled followed by reboot)	Press Enter	By pressing <enter> you will be asked if you really want to clear the TPM to factory settings.
TPM Enable/Disable Status	Enabled Disabled	Status info
TPM Owner Status	Unowned Owned	Status info

8.3.13 Advanced settings – USB Mass Storage Device Configuration

BIOS SETUP UTILITY	
Advanced	
USB Mass Storage Device Configuration USB Mass Storage Reset Delay [20 Sec] Emulation Type Default [Auto] Device #1 JetFlash TS256MJF2L Emulation Type [Auto]	Number of seconds POST waits for the USB mass storage device after start unit command. <- Select Screen Select Item +- change option F1 General Help F10 Save and Exit ESC Exit
v02.59+ (C)Copyright 1985-2005, American Megatrends, Inc.	

Feature	Options	Description
USB Mass Storage Reset Delay	10 Sec 20 Sec 30 Sec 40 Sec	Number of seconds POST waits for the USB mass storage device after start unit command.
Emulation Type Default	Auto Floppy Forced FDD Hard Disk CDROM Unaffected	Decide default setting when the number of USB devices are changed. Please note that the Unaffected setting can lead to improper emulation setting.
Emulation Type	Auto Floppy Forced FDD Hard Disk CDROM	If Auto, USB devices less than 530MB will be emulated as Floppy and remaining as hard drive. Forced FDD option can be used to force a HDD formatted drive to boot as FDD (Ex. ZIP drive).

8.4 PCIPnP Menu

BIOS SETUP UTILITY	
PCIPnP	
Advanced PCI/PnP Settings Warning: Setting wrong values in below sections May cause system to malfunction. Plug & Play O/S [No] Allocate IRQ to PCI VGA [Yes] PCI Slot-2 IRQ Preference [Auto]	NO: lets the BIOS configure all the devices in the system. YES: lets the operating system configure Plug and Play (PnP) devices not required for boot if your system has a Plug and Play operating system. <- Select Screen Select Item +- change option F1 General Help F10 Save and Exit ESC Exit
v02.59+ (C)Copyright 1985-2005, American Megatrends, Inc.	

Feature	Options	Description
Plug & Play O/S	No * Yes	NO: lets the BIOS configure all the devices in the system. YES: lets the operating system configure Plug and Play (PnP) devices not required for boot if your system has a Plug and Play operating system.
Allocate IRQ to PCI VGA	Yes No	YES: Assigns IRQ to PCI VGA card if card request IRQ. NO: Does not assign IRQ to PCI VGA card even if card request an IRQ.
PCI Slot-2 IRQ Preference	Auto 3, 4, 5, 7, 9, 10, 11, 12, 14, 15	Manual IRQ selection. Not a guaranteed selection. COM and LPT setup has precedence over this setting.

8.5.1 Boot – Boot Settings Configuration

BIOS SETUP UTILITY	
Boot	
Boot Settings Configuration Quick Boot [Enabled] Quiet Boot [Disabled] AddOn ROM Display Mode [Force BIOS] Bootup Num-Lock [On] PS/2 Mouse Support [Auto] Wait for 'F1' If Error [Enabled] Hit 'DEL' Message Display [Enabled] Interrupt 19 Capture [Disabled] PC Speaker/Beep [Enabled] Force boot Device [Disabled]	Configure Settings during System Boot. <- Select Screen Select Item Enter Go to Sub Screen F1 General Help F10 Save and Exit ESC Exit
v02.59+ (C)Copyright 1985-2005, American Megatrends, Inc.	

Feature	Options	Description
Quick Boot	Enabled Disabled	Allows BIOS to skip certain test while booting in order to decrease boot time.
Quiet Boot	Disabled Enabled	Disabled: Displays normal POST messages. Enabled: Displays OEM Logo instead of POST messages.
Long Splash	Disabled WinXP™ Vista™	(Long Splash only available if Quiet Boot). WinXP™: Boot logo until WinXP boots. Vista™: Boot logo until Vista boots.
AddOn ROM Display Mode	Force BIOS Keep current	Set display mode for Option ROM.
Bootup Num-Lock	Off On	Select Power-on state for numlock
PS/2 Mouse Support	Disabled Enabled Auto	Select support for PS/2 Mouse.
Wait for 'F1' If Error (see note)	Disabled Enabled	Wait for F1 key to be pressed if error occurs.
Hit 'DEL' Message Display	Disabled Enabled	Displays "Press DEL to run Setup" in POST.
Interrupt 19 Capture	Disabled Enabled	Enabled: Allows option ROMs to trap interrupt 19
PC Speaker/Beep	Disabled Enabled	Control the default beeps during boot of the system. This setting also control the beep during enumeration and (un)plug of USB.
Force boot Device	Disabled Primary IDE Master Primary IDE Slave Secondary IDE Master Secondary IDE Slave Third IDE Master Third IDE Slave Network	Does override current boot setting. Device must be in the boot priority menu though. If the device fails to boot, will not try other devices.

Note: List of errors:

<INS> Pressed

Timer Error

Interrupt Controller-1 error

Keyboard/Interface Error

Halt on Invalid Time/Date

NVRAM Bad

Primary Master Hard Disk Error

S.M.A.R.T HDD Error

Cache Memory Error

DMA Controller Error

Resource Conflict

Static Resource Conflict

PCI I/O conflict

PCI ROM conflict

PCI IRQ conflict

PCI IRQ routing table error

8.5.2 Boot – Boot Device Priority

BIOS SETUP UTILITY	
Boot	
Boot Device Priority 1st Boot Device [ESS-ST380811AS]	Specifies the boot sequence from the available devices. A device enclosed in paranthesis has been disabled in the corresponding type menu. <- Select Screen Select Item Enter Go to Sub Screen F1 General Help F10 Save and Exit ESC Exit
v02.59+ (C)Copyright 1985-2005, American Megatrends, Inc.	

Note: When pressing <F11> while booting it is possible manually to select boot device.

8.6 Security Menu

BIOS SETUP UTILITY	
Main	Advanced PCIPnP Boot Security Chipset Exit
Security Settings Supervisor Password :Installed User Password :Installed Change Supervisor Password Change User Password Boot Sector Virus Protection [Disabled]	Install or Change the password. <- Select Screen Select Item Enter Go to Sub Screen F1 General Help F10 Save and Exit ESC Exit
Hard Disk Security <hr/> Primary Master HDD User Password Primary Slave HDD User Password Secondary Slave HDD User Password	
v02.59+ (C)Copyright 1985-2005, American Megatrends, Inc.	

Feature	Options	Description
Change Supervisor Password	Password	Change the Supervisor Password
Change User Password	Password	Change the User Password
Boot Sector Virus Protection	Enabled Disabled	Will write protect the MBR when the BIOS is used to access the harddrive
HDD Password	Password	Locks the HDD with a password, the user needs to type the password on power on

8.7 Chipset Menu

BIOS SETUP UTILITY						
Main	Advanced	PCIPnP	Boot	Security	Chipset	Exit
Advanced Chipset Settings Warning: Setting wrong values in below sections may cause system to malfunction. ▶ North Bridge Configuration ▶ South Bridge Configuration					Configures North Bridge features. <- Select Screen Select Item Enter Go to Sub Screen F1 General Help F10 Save and Exit ESC Exit	
v02.59+ (C)Copyright 1985-2005, American Megatrends, Inc.						

8.7.1 Advanced Chipset Settings – North Bridge Chipset Configuration

BIOS SETUP UTILITY	
Chipset	
North Bridge Chipset Configuration Memory Remap Feature [Enabled] PCI MMIO Allocation : 4GB To 2816MB DRAM Frequency [Auto] Configure DRAM Timing by SPD [Enabled] Memory Hole [Disabled] Initiate Graphic Adapter [PEG/PCI] Internal Graphics Mode Select [Enabled, 8MB] ▶ Video Function Configuration	ENABLE: Allow remapping of overlapped PCI memory above the total physical memory DISABLE: Do not allow remapping of memory <- Select Screen Select Item Enter Go to Sub Screen F1 General Help F10 Save and Exit ESC Exit
v02.59+ (C)Copyright 1985-2005, American Megatrends, Inc.	

Feature	Options	Description
Memory Remap Feature	Enabled Disabled	ENABLE: Allow remapping of overlapped PCI memory above the total physical memory DISABLE: Do not allow remapping of memory
DRAM Frequency	Auto 533 MHz 677 MHz 800 MHz 1067 MHz	Auto 533 MHz 677 MHz 800 MHz 1067 MHz
Configure DRAM Timing by SPD	Enabled Disabled	Enabled Disabled
Memory Hole [Disabled]	[Disabled] 15MB-16MB	[Disabled] 15MB-16MB
Initiate Graphic Adapter	IGD PCI/IGD PCI/PEG PEG/IGD PEG/PCI	Select which graphics controller to use as the primary boot device.
Internal Graphics Mode Select	Disabled Enabled, 1MB Enabled, 8MB	Select the amount of system memory used by the Internal graphics device.

8.7.2 Advanced Chipset Settings – Video Function Configuration

BIOS SETUP UTILITY	
Chipset	
Video Function Configuration	
DVMT Mode Select DVMT/ Fixed Memory	[DVMT Mode] [256MB]
Boot Type:	[AUTO]
EDID Support	[Enabled]
SDVO	[N/A]
Fixed Mode DVMT Mode <- Select Screen Select Item Enter Go to Sub Screen F1 General Help F10 Save and Exit ESC Exit	
v02.59+ (C)Copyright 1985-2005, American Megatrends, Inc.	

Feature	Options	Description
DVMT Mode Select	Fixed Mode DVMT Mode	Setup Video memory mode. When Fixed then 128MB or 256MB (se below) will always be present. When DVMT then memory will be dynamically adjusted up to 128MB or 256MB (se below) when needed.
DVMT/ Fixed Memory	128MB 256MB	128MB 256MB
Boot Type	Default CRT LFP CRT+LFP EFP TV CRT+EFP CRT+TV EFP+EFP2 EFP+TV CRT+CRT2	Type of boot Screen CRT is onboard CRT VGA ouput. The settings involving LFP, EFP, EFP2, TV and CRT2 are only relevant if SDVO card is installed. SDVO options: LFP is LVDS panel no. 1. EFP is DVI panel no. 1. EFP2 is DVI panel no. 2. TV is TV (not available at present time) CRT2 is second CRT.
EDID Support	Enabled Disabled	LVDS Auto Configuration using EEPROM.
SDVO	N/A DVI – D DVI – I CRT (Panel type see description ->)	N/A when no ADD2 card is installed. DVI-D when ADD2-DVI card is installed. Optional for DVI + CRT card. CRT when ADD2-CRT card is installed. If ADD2 LVDS card is connected select requested resolution/display type.

8.7.3 Advanced Chipset Settings – SouthBridge Configuration

BIOS SETUP UTILITY	
Chipset	
South Bridge Chipset Configuration	Disabled 2 USB Ports 4 USB Ports 6 USB Ports 8 USB Ports 10 USB Ports
USB Functions [10 USB Ports]	
USB 2.0 Controller [Enabled]	
HAD Controller [Enabled]	
Audio Jack Sensing [Auto]	
SMBUS Controller [Enabled]	
SLP_S4# Min. Assertion Width [Disabled]	
Restore on AC Power loss [Last State]	
	<- Select Screen Select Item Enter Go to Sub Screen F1 General Help F10 Save and Exit ESC Exit
v02.59+ (C)Copyright 1985-2005, American Megatrends, Inc.	

Feature	Options	Description
USB Functions	Disabled 2 USB Ports 4 USB Ports 6 USB Ports 8 USB Ports 10 USB Ports	Disabled 2 USB Ports, USB0/1 4 USB Ports, USB0/1/2/3 6 USB Ports, USB0/1/2/3/4/5 8 USB Ports, USB0/1/2/3/4/5/6/7 10 USB Ports, all USB ports
USB 2.0 Controller	Enabled Disabled	Disabled only possible if less than 10USB Ports are selected above.
HDA Controller	Enabled Disabled	Enabled Disabled
Audio Jack Sensing	Auto Disabled	Auto: The insertion of audio jacks are auto determined. Disabled: Driver assumes that all jacks are inserted (usefull when using Audio pinrow).
SMBUS Controller	Enabled Disabled	Enabled (for all known OS at present time) Disabled (only if required by OS etc.)
SLP_S4# Min. Assertion Width	Disabled 4 to 5 seconds 3 to 4 seconds 2 to 3 seconds 1 to 2 seconds	Extra delay before turning on/off on board power system when leaving/entering S4 (power down state, Suspend to disk).
Restore on AC Power loss	Power Off Power On Last State	Power Off Power On Last State

8.8 Exit Menu

BIOS SETUP UTILITY						
Main	Advanced	PCIPnP	Boot	Security	Chipset	Exit
Exit Options Save Changes and Exit Discard Changes and Exit Discard Changes Load Optimal Defaults Load Failsafe Defaults <hr/> Halt on invalid Time/Date [Enabled] Secure CMOS [Disabled]					Exit system setup after saving the changes. F10 Key can be used for this operation. <- Select Screen Select Item Enter Go to Sub Screen F1 General Help F10 Save and Exit ESC Exit	
v02.59+ (C)Copyright 1985-2005, American Megatrends, Inc.						

Feature	Options	Description
Save Changes and Exit	Ok Cancel	Exit system setup after saving the changes
Discard Changes and Exit	Ok Cancel	Exit system setup without saving any changes
Discard Changes	Ok Cancel	Discards changes done so far to any of the setup questions
Load Optimal Defaults	Ok Cancel	Load Optimal Default values for all the setup questions
Load Failsafe Defaults	Ok Cancel	Load Failsafe Default values for all the setup questions
Halt on invalid Time/Date	Enabled Disabled	
Secure CMOS	Enabled Disabled	Enable will store current CMOS in non volatile ram. This will maintain the settings even if battery is failing.

8.9 AMI BIOS Beep Codes

Boot Block Beep Codes:

Number of Beeps	Description
1	Insert diskette in floppy drive A:
2	'AMIBOOT.ROM' file not found in root directory of diskette in A:
3	Base Memory error
4	Flash Programming successful
5	Floppy read error
6	Keyboard controller BAT command failed
7	No Flash EPROM detected
8	Floppy controller failure
9	Boot Block BIOS checksum error
10	Flash Erase error
11	Flash Program error
12	'AMIBOOT.ROM' file size error
13	BIOS ROM image mismatch (file layout does not match image present in flash device)

POST BIOS Beep Codes:

Number of Beeps	Description
1	Memory refresh timer error.
2	Parity error in base memory (first 64KB block)
3	Base memory read/write test error
4	Motherboard timer not operational
5	Processor error
6	8042 Gate A20 test error (cannot switch to protected mode)
7	General exception error (processor exception interrupt error)
8	Display memory error (system video adapter)
9	AMIBIOS ROM checksum error
10	CMOS shutdown register read/write error
11	Cache memory test failed

Troubleshooting POST BIOS Beep Codes:

Number of Beeps	Troubleshooting Action
1, 2 or 3	Reseat the memory, or replace with known good modules.
4-7, 9-11	Fatal error indicating a serious problem with the system. Consult your system manufacturer. Before declaring the motherboard beyond all hope, eliminate the possibility of interference by a malfunctioning add-in card. Remove all expansion cards except the video adapter. <ul style="list-style-type: none"> • If beep codes are generated when all other expansion cards are absent, consult your system manufacturer's technical support. • If beep codes are not generated when all other expansion cards are absent, one of the add-in cards is causing the malfunction. Insert the cards back into the system one at a time until the problem happens again. This will reveal the malfunctioning card.
8	If the system video adapter is an add-in card, replace or reseat the video adapter. If the video adapter is an integrated part of the system board, the board may be faulty.

9. OS setup

Use the Setup.exe files for all relevant drivers. The drivers can be found on KT965 Driver CD or they can be downloaded from the homepage <http://emea.kontron.com/>

Note: When installing/using ADD2 it is possible that the OS start up without any connected display(s) active. If you are able to pass the "Log On to Windows" etc. by entering the password etc. without actually see the picture on the display and If the Hot Keys have not been disabled in the Extreme Graphic driver then the following key combinations you can select a connected display:

<Ctrl><Alt><F1> enables the CRT (on board)

<Ctrl><Alt><F4> enables display conneted to the ADD2 card.

Before installing Windows XP SP3 be sure to use BIOS version 011 (KT965011) or above.

10. Warranty

KONTRON Technology warrants its products to be free from defects in material and workmanship during the warranty period. If a product proves to be defective in material or workmanship during the warranty period, KONTRON Technology will, at its sole option, repair or replace the product with a similar product. Replacement Product or parts may include remanufactured or refurbished parts or components.

The warranty does not cover:

1. Damage, deterioration or malfunction resulting from:
 - A. Accident, misuse, neglect, fire, water, lightning, or other acts of nature, unauthorized product modification, or failure to follow instructions supplied with the product.
 - B. Repair or attempted repair by anyone not authorized by KONTRON Technology.
 - C. Causes external to the product, such as electric power fluctuations or failure.
 - D. Normal wear and tear.
 - E. Any other causes which does not relate to a product defect.
2. Removal, installation, and set-up service charges.

Exclusion of damages:

KONTRON TECHNOLOGY LIABILITY IS LIMITED TO THE COST OF REPAIR OR REPLACEMENT OF THE PRODUCT. KONTRON TECHNOLOGY SHALL NOT BE LIABLE FOR:

1. DAMAGE TO OTHER PROPERTY CAUSED BY ANY DEFECTS IN THE PRODUCT, DAMAGES BASED UPON INCONVENIENCE, LOSS OF USE OF THE PRODUCT, LOSS OF TIME, LOSS OF PROFITS, LOSS OF BUSINESS OPPORTUNITY, LOSS OF GOODWILL, INTERFERENCE WITH BUSINESS RELATIONSHIPS, OR OTHER COMMERCIAL LOSS, EVEN IF ADVISED OF THEIR POSSIBILITY OF SUCH DAMAGES.
2. ANY OTHER DAMAGES, WHETHER INCIDENTAL, CONSEQUENTIAL OR OTHERWISE.
3. ANY CLAIM AGAINST THE CUSTOMER BY ANY OTHER PARTY.