

# Technical Manual

## *ePanel-mgx*

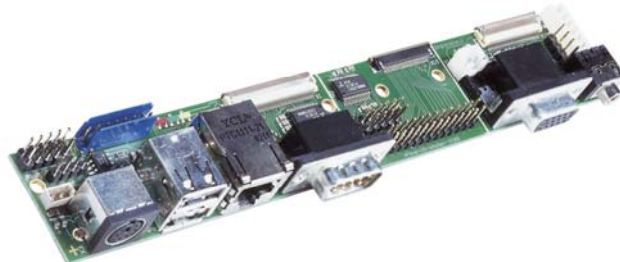
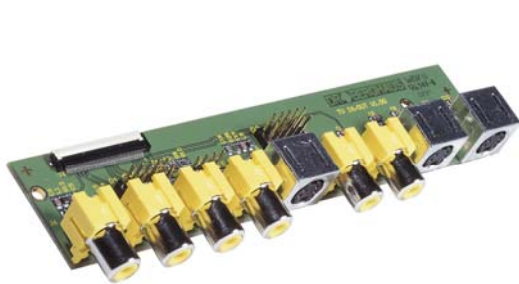
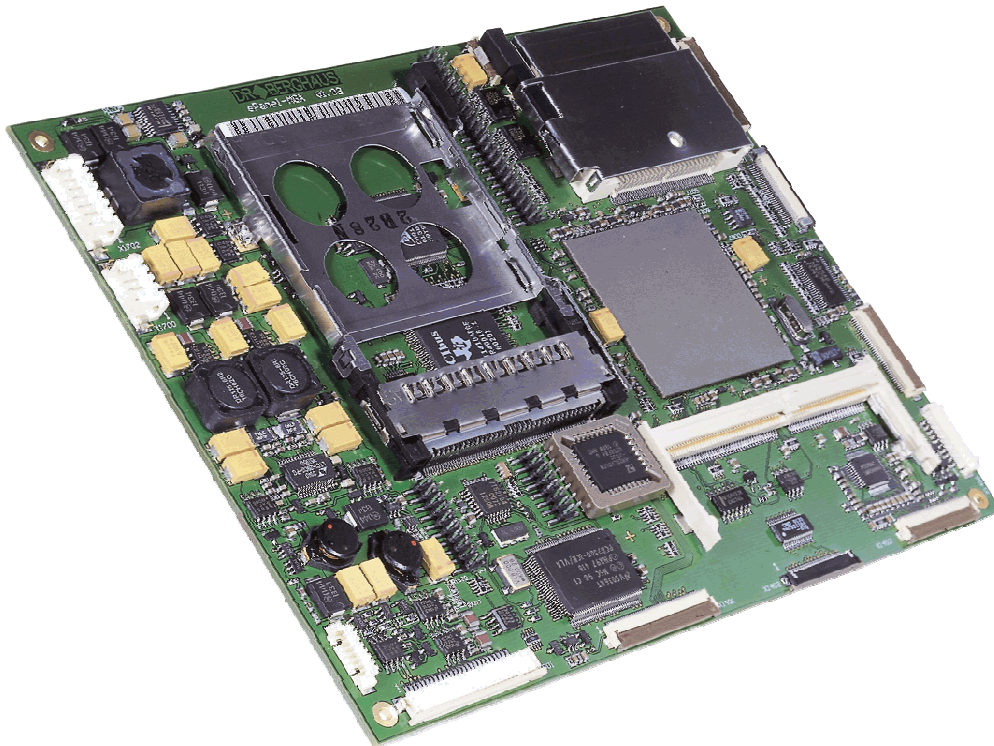

# 1. TABLE OF CONTENTS

<b>1. TABLE OF CONTENTS .....</b>	<b>2</b>
1.1. User Information .....	3
1.2. Trademarks.....	3
1.3. General.....	3
1.4. Warranty .....	3
1.5. Support, problems and failure analysis .....	4
<b>2. INTRODUCTION .....</b>	<b>5</b>
2.1. Kontron ePanel-Concept .....	5
2.2. ePanel-mgx.....	6
<b>3. FEATURES.....</b>	<b>7</b>
<b>4. RESOURCE LIST AND I/O MAP .....</b>	<b>9</b>
<b>5. CONNECTOR LOCATIONS AND PINOUTS .....</b>	<b>10</b>
5.1. Connector locations.....	10
5.2. Connector pinouts .....	11
5.3. Connector pinouts .....	12
5.4. Connector pinouts .....	13
5.5. Pin descriptions .....	14
<b>6. BIOS-DESCRIPTION .....</b>	<b>26</b>
6.1. The Setup Guide.....	26
6.2. BIOS Update with SC12xUPD.EXE .....	31
<b>7. HARDWARE DESCRIPTION .....</b>	<b>32</b>
7.1. GEODE SC1200 Processor .....	32
7.2. Onboard VGA .....	33
7.3. Watchdog.....	34
7.4. Sound .....	36
7.5. Compact Flash Socket (True IDE compatible).....	36
7.6. Ethernet 10BASE-T/100BASE-TX LAN .....	36
7.7. Smart battery charger .....	37
7.8. Video Input / Output.....	37
7.9. Wide range DC power supply.....	37
7.10. PC-Card Interface.....	37
7.11. Flatpanel-Interface.....	38
7.12. Backlight control and power supply.....	38
<b>8. JUMPER SETTINGS .....</b>	<b>39</b>
<b>9. MECHANICAL DIMENSIONS.....</b>	<b>40</b>
<b>10. EVALUATION I/O-ADAPTERS.....</b>	<b>41</b>
<b>11. SPECIFICATIONS.....</b>	<b>43</b>
11.1. Mechanical specifications.....	43
11.2. Electrical specifications .....	43
11.3. Environmental specifications .....	43
<b>12. LITERATURE, STANDARDS AND LINKS.....</b>	<b>44</b>
12.1. ISA-Bus, standard connectors.....	44
12.2. PCI specifications .....	44
12.3. RS232C .....	44
12.4. USB.....	44
12.5. Smart Battery System Specification ( SBS ) .....	44
<b>13. DOCUMENT REVISION HISTORY .....</b>	<b>45</b>

## 1.1. User Information

Copyright 2002 Kontron Hamburg GmbH & Co.KG.

In this document Kontron Hamburg GmbH & Co.KG will also be referred to by the short form "**Kontron**".

The information in this document has been carefully checked and is believed to be accurate and reliable. However, no responsibility is assumed for inaccuracies. Furthermore, **Kontron** reserves the right to make changes to any portion of this manual to improve reliability, function or design. **Kontron** does not assume any liability for any product or circuit described herein.

## 1.2. Trademarks

AT and IBM are trademarks of International Business Machines

XT, AT, PS/2 and Personal System/2 are trademarks of International Business Machines Corporation.

Microsoft is a registered trademark of Microsoft Corporation.

Intel is a registered trademark of Intel Corporation.

All other products and trademarks mentioned in this manual are trademarks of their respective owners.

## 1.3. General

For the circuits, descriptions and tables indicated no responsibility is assumed as far as patents or other rights of third parties are concerned.

The information in the chapter Technical Descriptions describes the type of the boards and shall not be considered as assured characteristics.

The reproduction, transmission or use of this document or its contents is not permitted without expressed written authority.

Offenders will be liable for damages. All rights created by patent grant or registration of a utility model or design, are reserved.

(c) Kontron Hamburg GmbH & Co.KG 2002

## 1.4. Warranty

Each board is tested carefully and thoroughly before being shipped. If, however, problems should occur during operation, please check your user specific settings of all boards included in your system. This is often the source of problems due to resource conflicts. If a board is defective, it can be sent to your supplier for repair. Please take care of the following steps:

1. The board returned should have the factory default settings since a test is only possible with these settings.
2. In order to repair your board as fast as possible we require some additional information from you (detailed description of how and when did the problem occur, what is exactly the problem and so on).
3. Upon receipt of returned boards please be aware that your user specific settings could have been changed during repair.

Within the warranty period the repair is free of charge as long as the warranty conditions are observed. Because of the high test expenditure you will be charged with the test cost if no fault is found. Repair after the warranty period will be charged.

This **Kontron** product is warranted against defects in material and workmanship for the warranty period from the date of shipment. During the warranty period **Kontron** will at its option either repair or replace defective products.

For warranty service or repair the product must be returned to a service facility designated by **Kontron**.

The foregoing warranty shall not apply to defects resulting from improper or inadequate maintenance or handling by buyer, unauthorized modification or misuse, operation outside of the product's environmental specifications or improper installation or maintenance.

**Kontron** will not be responsible for any defects or damages to other products not supplied by **Kontron** that are caused by a faulty **Kontron** product.

## 1.5. Support, problems and failure analysis

It is not in the responsibility of **Kontron** to supply you with informations about standard PC technology. Please find a selection of different information sources for your convenience in chapter Literature, standards, links

Before contacting **Kontron** please check first our web page for available information (newest manuals, application notes etc.). If you can't solve the problem on your own with this documents, do not hesitate to contact us by email or phone. Please prepare yourself to answer a few questions like

- which **Kontron** module(s) is(are) concerned?
- what serial numbers (xx???????)?
- what BIOS versions?
- since when is this problem known
- is this problem already reported (to whom?)
- and so on...

---

## 2. INTRODUCTION

---

### 2.1. Kontron ePanel-Concept

Time is something no one has enough. „Short time-to-market“ is a nightmare everybody suffers from. A new concept promises a lot of advantages, but how to use them in a non-existent time span? Especially embedded boards are not always easy connectable, think of tangling cables or missing adapters. Kontron recognized this problem and developed the **ePanel**, a platform for OEM and ODM. Its main benefit is the high integration of mobile accessories and components in conjunction with mechanical fit and function. To build a mobile computer, just use a battery, TFT display, inverter and housing and you're set. Now system design and application development gets a great boost forward. Others still look for adapters while your project already started. In order to stay close to state-of-the-art computer technologies of the desktop PC market, the ECT business (Embedded Computer Technology) demands adequate processor performance for many applications. There are many standards for CPU boards with a lot of advantages or restrictions. Unfortunately none of these products care about the increasing customer specialization. A board, which fits exactly into a system, is nearly impossible to find but **ePanel** fits nearly for all mobile and space-critical applications. Only a customized module will fulfill all requirements. But away from standard products, a customer has to tolerate long development cycles and costly problems with quick replacements or easy upgrades. The way out of this situation has to join two apparent opposites. The task is to create a customized PC board out of standard parts. Obviously the solution has to be modular. The answer of Kontron for the mobile business: **ePanel**.

#### **Quick integration and nevertheless standard PC technology.**

The **ePanel-mgx** is a complete Pentium® class PC with standard interfaces including USB and additional options such as sound capabilities, PC-Card, Touch & Matrix controller, TV-In and -Output, Flatpanel interface, and 100 MBit Ethernet, etc.

#### **Smallest Dimensions to meet smallest space requirements.**

With 252 cm<sup>2</sup> the **ePanel-mgx** uses only a little more space compared to a current slot CPU, which needs 219 cm<sup>2</sup>. But the most surprising fact is the module height. The **ePanel-mgx** measures only 10 mm!

#### **How about the ISA bus?**

The only way to extend the capabilities of the board is to plug in PC-Cards. No other bus systems are supported.

#### **There must be replacements or upgrades for future requirements.**

**Kontron** will expand and improve this innovative and handy ePanel concept. New PC technologies will be obtainable the same way as in other Kontron product families.

An **ePanel** board does not force you in excessive and expensive cabling. Only the really demanded interfaces are linked to the corresponding connectors. The decision is up to you, which one you call for or which one to skip. Evaluation adapters and kits are available.

#### **The application requests low power Pentium® performance.**

Don't worry about that. Depending on OS and used options, the **ePanel-mgx** consumes between 5.8 Watts depending on input voltage

#### **Finally the system passed all the tests and now?**

Nothing special, just start mass production. **Kontron** knows about the short life cycles of PC products. Therefore we secured by suitable methods, that longevity is one of the most excellent characteristics of the **ePanel family**.

## 2.2. ePanel-mgx

The **ePanel-mgx** is an extreme compact National Semiconductor® Geode™ SC1200 based PC module with consistent low power design. The National Semiconductor® Geode™ SC1200 processor allows the usage of the board without active or passive cooling in applications, where space limitations (the maximum height is only 10 mm!) are major requirements. It is now possible to create modular systems, combining exchangeable CPU performance with systems, carrying only the connectors and additional functions needed. This reduces development costs and speeds up application design. Despite the very little board dimensions, the **ePanel-mgx** offers all standard interfaces such as Sound, Ethernet, USB and Graphic. The fully compliant AC97 soundchip is supported by most operating systems. For networking purposes the **ePanel-mgx** comes with a 10/100 MBit Ethernet controller which allows an easy Intranet/Internet access. Total communication interfaces like 2 serial TTL ports, an EPP parallel port, Floppy-interface, **Touch & Matrix controller**, TV-In and -Output, 3 USB ports, PC-Card controller, 10/100 Mbit Ethernet, **battery charger for smart batteries** and a **wide range DC power supply**. A full function graphics accelerator contains a VGA (video graphics array) controller, bitBLT engine, and a ROP (raster operations) unit for complete GUI (graphical user interface) acceleration under most operating systems. You're looking for a secure and EMI tolerant boot medium? A Compact Flash socket for commercial CF-cards is already integrated on the module. For further expansions one additional IDE port is available.

## 3. FEATURES

- **32-bit x86 processor with MMX instruction set support**
  - National Semiconductor® Geode™ SC1200 processor with 266 MHz (33Mhz Bus clock)
- **Chipset**
  - Integrated Multi-Function South Bridge
- **Power Supply**
  - Wide range power supply : 8V DC up to 28V DC
  - Battery power supply with smart battery packs : 7V DC up to 18.4V DC
  - Integrated charging unit for batteries up to 18V
- **Cache**
  - 16KB cache integrated
- **Memory support, 64-bit SDRAM interface**
  - One SO-DIMM socket for up to 256 MB SDRAM-module
- **Two serial ports (COM1 and COM2)**
  - TTL signals only
- **One parallel port (LPT1)**
  - EPP capability
- **Floppy-interface**
  - Support for 1.44 MB density
- **EIDE-PCI-hard disk-interface**
  - 2 x PCI Bus Master IDE ports (up to 3 IDE Devices)
  - Compact Flash socket as Primary Master
  - 44 pin IDE connector as secondary Master/Slave
  - supports PIO Modes up to Mode 4
- **Three USB ports , OpenHCI specification compliant**
  - USB legacy support
  - USB floppy-boot support
- **PS/2-Keybaord and PS/2-Mouse**
- **IrDA interface (COM3)**
- **Watchdog**
- **320 kByte FLASH-BIOS (Insyde Software based, strategic partner of National Semiconductor)**
- **Real Time Clock**
- **Keyboard Controller**
- **NV-EEPROM for CMOS Setup**

- **Onboard Ethernet 10BASE-T/100BASE-TX LAN**  
DAVICOM DM9102A single chip Fast Ethernet NIC controller
- **Onboard VGA/LCD controller**  
Integrated 2D Graphics accelerator and Display controller that supports up to 1024x768x16 bpp.  
The Graphic memory must be shared from the system memory (up to 4MB)  
JILI (LVDS) and KAB-FLEX32 TFT interface up to XGA TFT Flatpanels
- **Onboard AC97 Rev. 2.0 compliant sound interface**
- **Onboard Compact Flash socket for commercial CF-cards (Master on primary IDE)**
- **Onboard PC-Card socket for Wireless LAN, Bluetooth, ISDN or modem cards**
- **NTSC/PAL Video decoder with hardware video accelerator**
- **CCIR-656 Video input port with direct video for full screen display**
- **Onboard 4/8-wire Touch controller**
- **Onboard 8x8 Keyboard Matrix controller**

## 4. RESOURCE LIST AND I/O MAP

IRQ #	used for	available	comment
0	Timer0	No	
1	Keyboard	No	
2	Cascade	No	
3	COM2	No	Note (1)
4	COM1	No	Note (1)
5	Sound	Yes	
6	FDC	No	Note (1)
7	LPT1	Yes	
8	RTC	No	
9	COM3	No	Note (1)
10	PC-Card	No	Note (1) PC-Card legacy interrupt
11	USB/Ethernet/PC-Card	No	Note (1) PCI interrupt sharing
12	PS/2 Mouse	Yes	
13	FPU	No	
14	IDE0	No	Note (1)
15	IDE1	No	Note (1)

DMA #	used for	available	comment
0		Yes	
1	Sound	Yes	
2	FDC	No	
3		Yes	
4	Cascade	No	
5	Sound	Yes	
6		Yes	
7		Yes	

Upper Memory	used for	available	comment
C0000h – CBFFFh	VGA BIOS	No	
CC000h – CFFFFh	System-BIOS	No	
D0000h – DFFFFh		Yes	ISA bus or shadow RAM (e.g. for extension ROM)
DE000h – DFFFFh	System BIOS	No	
E0000h – EFFFFh	System-BIOS	No	
F0000h – EC000h	System BIOS	No	

The I/O-port addresses 000h-3FFh of the **ePanel-mgx** are functionally identical with a standard PC/AT. Following the additional I/O ports which are used on this board:

I/O address	used for	available	comment
220-22Fh	Sound	Yes	Only one choice is possible
240-24Fh	Sound	Yes	Only one choice is possible
260-26Fh	Sound	Yes	Only one choice is possible
280-28Fh	Sound	Yes	Only one choice is possible
2E0-2E7h	Serial port	No	Serial Debug Port
2E8-2EFh	COM4	Yes	Instead of COM1/2/3
2F8-2FFh	COM2	No	Note (1)
378-37Fh	LPT1	No	Note (1)
3C0-3E1h	VGA	No	
3E8-3EFh	COM3	No	Note (1)
3F0-3F7h	Floppy	No	Note (1)
3F8-3FFh	COM1	No	Note (1)
400-FFFFh	Geode SC1200	Yes/No	Some addresses are used. For details contact your distributor or KONTRON

**Notes:**

(1) If the „used for“-device is disabled in setup, the corresponding interrupt is available for other devices.



## 5.2. Connector pinouts

Pin-No.	Smart Battery Connector	DC Input Connector	Backlight Connector	Floppy Connector	Matrix Keyboard Connector	Touch Panel Connector	Debug Connector	Pin-No.
	X1702	X1700	X904	X801	X1405	X1404	X1406	No.
1	BAT+	DCIN	NC	VCC5	GND	GND	GND	1
2	BAT+	DCIN	BKLT_ADJ	INDEXJ	VCC3	YB	CPU_SIN1	2
3	MEM_SCL	GND	GND	VCC5	MKBD_O0	SYB	CPU_SOUT1	3
4	MEM_SDA	GND	BKLT_SW	DR0#	MKBD_O1	GND	VCC5	4
5	THM		BKLT_SW	VCC5	MKBD_O2	YT	VCC5	5
6	GND		GND	DSKCHG	MKBD_O3	SYT	DDC_SCL	6
7	GND		BKLT_ON	NC	MKBD_O4	GND	DDC_SDA	7
8				NC	MKBD_O5	XL	GND	8
9				NC	MKBD_O6	SXL	VCC12	9
10				MTR0#	MKBD_O7	GND	BBATT+	10
11				NC	GND	XR		11
12				FDIR	VCC3	SXR		12
13				NC	MKBD_I0	GND		13
14				STEP#	MKBD_I1	TRB#		14
15				GND	MKBD_I2	TLB#		15
16				WDATA#	MKBD_I3	GND		16
17				GND	MKBD_I4			17
18				WGATE#	MKBD_I5			18
19				GND	MKBD_I6			19
20				TRK0#	MKBD_I7			20
21				GND				21
22				WRTPRT#				22
23				GND				23
24				RDATA#				24
25				GND				25
26				HDSEL				26

### 5.3. Connector pinouts

Pin-No.	IDE Connector	TV-Out/In Connector	Flatpanel (FLEX32) Connector	Flatpanel (JILI) Connector	VGA/Sound Connector	COM2/LPT1 Connector	USB/COM1/KEYB/PS2/Ethernet Connector	Pin-No.
	X1203	X1400	X903	X905	X1402	X1403	X1401	No.
1	PIDE_RST#	VI_GND	GND	DETECT	GND	VCC5	VCC5	1
2	GND	CVBS_IN1	PCLK	LCDDO0	AUX_L	GND	KBCLK	2
3	PIDE_D7	VI_GND	PHS	LCDDO1	GND	DSR2#	KBDAT	3
4	PIDE_D8	CVBS_IN2	PVS	VDDON	AUX_R	DCD2#	GND	4
5	PIDE_D6	VI_GND	GND	LCDDO2	GND	DTR2#	MDAT	5
6	PIDE_D9	Y_IN1	PR0	LCDDO3	VLINE_L	RTS2#	MCLK	6
7	PIDE_D5	VI_GND	PR1	NC	GND	CTS2#	GND	7
8	PIDE_D10	C_IN1	PR2	LCDDO4	VLINE_R	SIN2	DSR1#	8
9	PIDE_D4	VI_GND	PR3	LCDDO5	GND	SOUT2	DCD1#	9
10	PIDE_D11	Y_IN2	PR4	GND	CD_L	RI2#	DTR1#	10
11	PIDE_D3	VI_GND	PR5	LCDDO6	CD_GND	GND	RTS1#	11
12	PIDE_D12	C_IN2	GN6	LCDDO7	CD_R	AFD#	CTS1#	12
13	PIDE_D2	VI_GND	PG0	GND	GND	STB	SIN1	13
14	PIDE_D13	Y_IN3	PG1	LCDDO8	MIC	ERR#	SOUT1	14
15	PIDE_D1	VI_GND	PG2	LCDDO9	GND	PD0	RI1#	15
16	PIDE_D14	C_IN3	PG3	JILI_SDA	LINE_L	INIT#	GND	16
17	PIDE_D0	VI_GND	PG4	LCDDO10	GND	GND	IRRX1	17
18	PIDE_D15	RGB_SYNC1	PG5	LCDDO11	LINE_R	PD1	IRTX1	18
19	GND	VI_GND	GND	JILI_SCL	GND	SLIN#	GND	19
20	NC	RGB_RED1	PB0	LCDDO12	VCC5	PD2	VCC5	20
21	SIDE_DRQ	VI_GND	PB1	LCDDO13	VCC5	PD3	VCC5	21
22	GND	RGB_GREEN1	PB2	GND	VCC5	GND	VCC5	22
23	SIDE_IOW#	VI_GND	PB3	LCDDO14	VCC5	PD4	VCC5	23
24	GND	RGB_BLUE1	PB4	LCDDO15	GND	PD5	VCC5	24
25	SIDE_IOR#	VI_GND	PB5	GND	GREEN	PD6	USBEN	25
26	GND	RGB_SYNC2	GND	LCDDO16	GND	PD7	OVRCUR#	26
27	SIDE_IORDY	VI_GND	PDE	LCDDO17	BLUE	GND	GND	27
28	NC	RGB_RED2	PANEL_VCC	GND	GND	ACK#	USB0+	28
29	SIDE_DACK#	VI_GND	PANEL_VCC	LCDDO18	RED	BUSY#	USB0-	29
30	GND	RGB_GREEN2	R/L	LCDDO19	GND	PE	GND	30
31	SIDE_IRQ	VI_GND	U/D	VCC5	DDC_SDA	SLCT	USB1+	31
32	NC	RGB_BLUE2	RESERVED	VCC5	DDC_SCL	GND	USB1-	32
33	PIDE_A1	VI_GND	GND	VCC5	GND		GND	33
34	PDIAG_P	GND		VCC5	VGA_VS		USB2+	34
35	PIDE_A0	CVBS/TVG		BKLT_ON	GND		USB2-	35
36	PIDE_A2	GND		GND	VGA_HS		GND	36
37	PIDE_CS0#	SVC/TVB		GND	GND		RXD+	37
38	PIDE_CS1#	GND		VCC12	NC		RXD-	38

### 5.4. Connector pinouts

Pin-No.	IDE Connector	TV-Out/In Connector	Flatpanel (FLEX32) Connector	Flatpanel (JILI) Connector	VGA/Sound Connector	COM2/LPT1 Connector	USB/COM1/KEYB/PS2/Ethernet Connector	Pin-No.
	X1203	X1400	X903	X905	X1402	X1403	X1401	No.
39	DASP_P	SVY/TVR		VCC12	NC		GND	39
40	GND	GND		VCC12	BCKBAT+		TXD+	40
41	VCC5	CVBS					TXD-	41
42	VCC5	GND					GND	42
43	GND	VCC3					LILED	43
44	NC	VCC3					SPEEDLED	44
45		VCC5					ACTLED	45
46							VCC3	46
47							LED#	47
48							MR#	48
49							PWRBTN#	49
50							GND	50

## 5.5. Pin descriptions

### 5.5.1. Connector X1402 (VGA / Sound)

#### **BCKBAT**

3V backup cell input. BATT should be connected to a 3V backup cell for RTC operation and storage register non-volatility in the absence of system power. (VBATT = 2.4 - 3.3V)

#### **VGA\_HS**

Horizontal Sync: This output supplies the horizontal synchronization pulse to the monitor.

#### **VGA\_VS**

Vertical Sync: This output supplies the vertical synchronization pulse to the monitor.

#### **RED, GREEN, BLUE**

CRT analog video outputs. Maximal output voltage is 0.7Vpp.

#### **DDC\_SCL, DDC\_SDA**

Bidirectional open collector DDC signals with TTL level. DDC not supported.

#### **AUX\_L**

Auxiliary input left. Maximal input voltage is 0.7Vpp.

#### **AUX\_R**

Auxiliary input right. Maximal input voltage is 0.7Vpp.

#### **VLINEL**

Line-level stereo input left. Maximal input voltage is 0.7Vpp.

#### **VLINER**

Line-level stereo input right. Maximal input voltage is 0.7Vpp.

#### **LINE\_L**

Line-level stereo output left. This pin can drive a 5k Ohm AC load. Maximal output voltage is 0.7Vpp.

#### **LINE\_R**

Line-level stereo output right. This pin can drive a 5k Ohm AC load. Maximal output voltage is 0.7Vpp.

#### **CD\_L**

CD Line-level stereo input left. Maximal input voltage is 0.7Vpp.

#### **CD\_R**

CD Line-level stereo input right. Maximal input voltage is 0.7Vpp.

#### **CD\_GND**

CD Line input Ground.

#### **MIC**

Microphone input. Maximal input voltage is 0.7Vpp.

### 5.5.2. Connector X905 (JILI-Flatpanel-Interface)

#### JILI\_SCL, JILI\_SDA

These two pins are functionally suitable for a JILI interface between the graphics controller chip and the flatpanel cable. Open collector bidirectional signals (LVTTTL).

#### VDDON

Controls panel digital power. LVTTTL output.

#### BKLT\_ON

Backlight power control signal. LVTTTL output.

#### DETECT

Flat panel detection (not supported). LVTTTL input.

#### LCDDO0...19

LCD data output pins for one channel LVDS support (LVDS output).

Pin Name	LVDS signal	Channel
LCDDO0	Txout0-	first
LCDDO1	Txout0+	first
LCDDO2	Txout1-	first
LCDDO3	Txout1+	first
LCDDO4	Txout2-	first
LCDDO5	Txout2+	first
LCDDO6	Txclk-	first
LCDDO7	Txclk+	first
LCDDO8	not used	-
LCDDO9	not used	-
LCDDO10	not used	-
LCDDO11	not used	-
LCDDO12	not used	-
LCDDO13	not used	-
LCDDO14	not used	-
LCDDO15	not used	-
LCDDO16	not used	-
LCDDO17	not used	-
LCDDO18	not used	-
LCDDO19	not used	-

### 5.5.3. Connector X1401 (USB / COM1 / KEYB / PS2 / Ethernet)

**DTR1#**

Active low data terminal ready output for the serial port. Handshake output signal notifies modem that the UART is ready to establish data communication link (TTL).

**RI1#**

Active low input for the serial port. Handshake signal which notifies the UART that the telephone ring signal is detected by the modem (TTL).

**SOUT1**

Transmitter serial data output from serial port (TTL).

**SIN1**

Receiver serial data input (TTL).

**CTS1#**

Active low input for serial port. Handshake signal which notifies the UART that the modem is ready to receive data (TTL).

**RTS1#**

Active low output of serial port. Handshake signal notifies the modem that the UART is ready to transmit data (TTL).

**DCD1#**

Active low input for serial port. Handshake signal which notifies the UART that carrier signal is detected by the modem (TTL).

**DSR1#**

Active low input for serial port. Handshake signal which notifies the UART that the modem is ready to establish the communication link (TTL).

**KBDAT**

This is the Keyboard data signal (TTL).

**KBCLK**

This is the Keyboard clock signal (TTL).

**MDAT**

This is the Mouse data signal (TTL).

**MCLK**

This is the Mouse clock signal (TTL).

**IRTX1, IRRX1**

Infrared transmit and receive pin (LVTTTL).

**TXD-, TXD+**

Analog Twisted Pair Ethernet Transmit Differential Pair. These pins transmit the serial bit stream for transmission on the Unshielded Twisted Pair (UTP) cable. The current-driven differential driver can be two-level (10BASE-T) or three-level (100BASE-TX) signals depending on the mode of operation. These signals interface directly with an isolation transformer.

**RXD-, RXD+**

Analog Twisted Pair Ethernet Receive Differential Pair. These pins receive the serial bit stream from the isolation transformer. The bit stream can be two-level (10BASE-T) or three-level (100BASE-TX) signals depending on the mode of operation.

**ACTLED**

The Activity LED pin indicates either transmit or receive activity. When activity is present, the Activity LED is on; when no activity is present, the Activity LED is off.

**LILED**

The Link Integrity LED pin indicates link integrity. If the link is valid in either 10 or 100 Mbps, the LED is on; if link is invalid, the LED is off.

**SPEEDLED**

The Speed LED pin indicates the speed. The Speed LED will be on at 100 Mbps and off at 10 Mbps.

**USB0+, USB0-**

Universal Serial Bus Port 0. These are the serial data pairs for USB Port 0.

**USB1+, USB1-**

Universal Serial Bus Port 1. These are the serial data pairs for USB Port 1.

**USB2+, USB2-**

Universal Serial Bus Port 2. These are the serial data pairs for USB Port 2.

**OVRCUR#**

Over current detect input. This pin is used to monitor the USB power over current. Maximal input voltage is 3.3V DC.

**USBEN**

This output enables the USB ports. This pin is used to enable the USB power switch.

**PWRBTN#**

Power Button Input. This input is used to support the Power Button function. Used to power up or down the board. Maximal input voltage is 3.3V DC.

**LED#**

The LED# pin indicates the power status of the board. The LED# pin is an open collector output and will sink current to the connected LED if the device is active or will be inactive if the device is switched off.

**MR#**

The Manual Reset input pin. Short to ground will reset the device. Maximal input voltage is 3.3V DC.

#### 5.5.4. Connector X1403 (COM2 / LPT1)

All signals are TTL compatible.

**STB#**

This active low pulse is used to strobe the printer data into the printer.

**AFD#**

This active low output causes the printer to automatically feed one line after each line is printed.

**PD0...PD7**

This bi-directional parallel data bus is used to transfer information between CPU and peripherals.

**ERR#**

This active low signal indicates an error situation at the printer.

**INIT#**

This active low signal is used to initiate the printer when low.

**SLIN#**

This active low signal selects the printer.

**ACK#**

This active low output from the printer indicates it has received the data and is ready to receive new data.

**BUSY#**

This signal indicates the printer is busy and not ready to receive new data.

**PE**

This signal indicates that the printer is out of paper.

**SLCT**

This active high output from the printer indicates that it has power on.

**DTR2#**

Active low data terminal ready output for the serial port. Handshake output signal notifies modem that the UART is ready to establish data communication link.

**RI2#**

Active low input signal which notifies the UART that the telephone ring signal is detected by the modem.

**SOUT2**

Transmitter serial data output from serial port.

**SIN2**

Receiver serial data input.

**CTS2#**

Active low input handshake signal which notifies the UART that the modem is ready to receive data.

**RTS2#**

Active low output handshake signal notifies the modem that the UART is ready to transmit data.

**DCD2#**

Active low input handshake signal which notifies the UART that carrier signal is detected by the modem.

**DSR2#**

Active low input handshake signal which notifies the UART that the modem is ready to establish the communication link.

### 5.5.5. Connector X801 (Floppy)

All signals are TTL compatible.

**DR0#**

Drive select 0.

**INDEX#**

This active low Schmitt Trigger input signal senses from the disk drive that the head is positioned over the beginning of a track, as marked by an index hole.

**TRK0#**

This active low Schmitt Trigger input signal senses from the disk drive that the head is positioned over the outermost track.

**WRTPRT#**

This active-low Schmitt Trigger input signal senses from the disk drive that a disk is write-protected.

**RDATA#**

The active-low, raw data read signal from the disk is connected here. Each falling edge represents a flux transition of the encoded data.

**DSKCHG**

This disk interface input indicates when the disk drive door has been opened. This active-low signal is read from bit D7 of location base+7.

**MTR0#**

This active-low output selects motor drives 0.

**HDSEL#**

This active low output determines which disk drive head is active. Low = Head 0, high (open) = Head 1.

**FDIR#**

This active low output determines the direction of the head movement (low = step-in, high = step-out).

**STEP#**

This active low output signal produces a pulse at a software-programmable rate to move the head during a seek operation.

**WDATA#**

This active low output is a write-precompensated serial data to be written onto the selected disk drive. Each falling edge causes a flux change on the media.

**WGATE#**

This active-low, high-drive output enables the write circuitry of the selected disk drive.

### 5.5.6. Connector X1203 (Secondary IDE)

All signals are LVTTTL compatible.

#### **PIDE\_D0...15**

Secondary IDE ATA data bus. These are the data pins connected to secondary channel.

#### **PIDE\_A0...2**

Secondary IDE ATA address bus. These are the address pins connected to secondary channel.

#### **PIDE\_CS0#**

IDE Chip Select 1 for secondary channel 0. This is the Chip Select 1 command output pin to enable the secondary IDE device to watch the read/write command.

#### **PIDE\_CS1#**

IDE Chip Select 3 for secondary channel 1. This is the Chip Select 3 command output pin to enable the secondary IDE device to watch the read/write command.

#### **SIDE\_DRQ**

Secondary IDE DMA Request for IDE Master. This is the input pin from the secondary channel IDE DMA request to do the IDE Master transfer.

#### **SIDE\_DACK#**

Secondary IDE DACK for IDE Master. This is the output pin to grant the secondary channel IDE DMA request to begin the IDE Master transfer.

#### **SIDE\_IORDY**

Secondary IDE Ready. This is the input pin from the secondary IDE channel to indicate the IDE device is ready to terminate the IDE command in PIO mode. The IDE device can deassert this input (logic 0) to expand the IDE command if the device is not ready.

#### **SIDE\_IOR#**

Secondary IDE IOR command. This is the IOR command output pin to notify the secondary IDE device to assert the read data in PIO and DMA mode.

#### **SIDE\_IOW#**

Secondary IDE IOW command. This is the IOW command output pin to notify the secondary IDE device that the available write data is already asserted by IDE Busmaster in PIO and DMA mode.

#### **DASP\_P**

Time-multiplexed, open collector output which indicates that a drive is active, or that a slave drive is present on secondary IDE channel. Necessary for using IDE master/slave-mode on secondary IDE channel.

#### **PDIAG\_P**

Output by the drive if it is jumpered in the slave mode; input to the drive if it is jumpered in the master mode. The signal indicates to a master that the slave has passed its internal diagnostic command. Necessary for using IDE master/slave-mode on secondary IDE channel.

#### **PIDE\_RST#**

Low active hardware reset (RSTDRV inverted).

#### **SIDE\_IRQ**

Secondary channel interrupt signal.

### 5.5.7. Connector X1702 (Smart Battery System)

**BAT+**

Connect to positive terminal of battery.

**BAT-**

Connect to negative terminal of battery.

**MEM\_SDA**

Smart battery data bus signal. Open collector bidirectional (TTL).

**MEM\_SCL**

Smart battery clock signal. Open collector bidirectional (TTL).

**THM**

Thermal monitor input signal. Analog input, maximal input voltage is 4V DC.

### 5.5.8. Connector X1700 (DC Power Input)

**DCIN**

Main power supply input (8V - 28V DC).

**GND**

Main power supply ground.

### 5.5.9. Connector X904 (Backlight)

**NC**

Not connected.

**BKLT\_ADJ**

0-4V DC brightness control signal.

**BKLT\_SW**

Switched backlight power supply. 5V or 12V selectable by J910.

**BKLT\_ON**

Backlight on/off control signal (TTL). Polarity selectable by J911.

### 5.5.10. Connector X1405 (Matrix Keyboard)

**MKBD\_O0...MKBD\_O7**

Matrix keyboard outputs. Maximal output voltage is 3.3V DC.

**MKBD\_I0...MKBD\_I7**

Matrix keyboard inputs. Maximal input voltage is 3.3V DC.

### 5.5.11. Connector X1404 (Touch Panel)

**YB**

Touch panel bottom driving signal.

**SYB**

Touch panel bottom sensing signal. For 4-wire touch panels connect to YB.

**YT**

Touch panel top driving signal.

**SYT**

Touch panel top sensing signal. For 4-wire touch panels connect to YT.

**XL**

Touch panel left driving signal.

**SXL**

Touch panel left sensing signal. For 4-wire touch panels connect to XL.

**XR**

Touch panel right driving signal.

**SXR**

Touch panel right sensing signal. For 4-wire touch panels connect to XR.

**TRB#**

Touch panel right mouse button. Open collector input. Maximal input voltage is 5V DC.

**TLB#**

Touch panel left mouse button. Open collector input. Maximal input voltage is 5V DC.

### 5.5.12. Connector X1406 (Debug Interface)

#### CPU\_SOUT1

Transmitter serial data output from serial port (LVTTL).

#### CPU\_SIN1

Receiver serial data input (LVTTL).

#### DDC\_SCL, DDA\_SDA

These two pins are functionally suitable for a DDC interface between the graphics controller chip and the CRT monitor. Open collector bidirectional signals with TTL level (pulled up).

#### BBATT

3V backup cell input. BATT should be connected to a 3V backup cell for RTC operation and storage register non-volatility in the absence of system power. (VBATT = 2.4 - 3.3V DC)

### 5.5.13. Connector X903 (FLEX32 Interface)

All signals are LVTTL compatible.

#### PR0-PR5

Red color data lines for flatpanel.

#### PG0-PG5

Green color data lines for flatpanel.

#### PB0-PB5

Blue color data lines for flatpanel.

#### PCLK

Data shift clock for flatpanel.

#### PHS

Horizontal sync pulse for flatpanel.

#### PVS

Vertical sync pulse for flatpanel.

#### PDE

Data enable signal for flatpanel.

#### Panel\_VCC

Switched Power supply for flatpanel. **Caution:** adjust correct voltage setting with J906

#### R/L

Rotate image in right or left direction (only panel feature). Adjust correct setting with J909

#### U/D

Rotate image up or down (only panel feature). Adjust correct setting with J908

### 5.5.14. Connector X1400 (TV-Out/In)

**VI\_GND**

Ground line for video input signals.

**CVBS\_IN1**

This is video input signal for CVBS, channel 1. Maximal input voltage is 1Vpp.

**CVBS\_IN2**

This is video input signal for CVBS, channel 2. Maximal input voltage is 1Vpp.

**Y\_IN1**

This is video input signal for Y component, channel 1. Maximal input voltage is 1Vpp.

**C\_IN1**

This is video input signal for C component, channel 1. Maximal input voltage is 1Vpp.

**Y\_IN2**

This is video input signal for Y component, channel 2. Maximal input voltage is 1Vpp.

**C\_IN2**

This is video input signal for C component, channel 2. Maximal input voltage is 1Vpp.

**Y\_IN3**

This is video input signal for Y component, channel 3. Maximal input voltage is 1Vpp.

**C\_IN3**

This is video input signal for C component, channel 3. Maximal input voltage is 1Vpp.

**RGB\_SYNC1**

This is sync pulse for RGB video input signal, channel 1. Maximal input voltage is 1Vpp.

**RGB\_SYNC2**

This is sync pulse for RGB video input signal, channel 2. Maximal input voltage is 1Vpp.

**RGB\_RED1**

This is red input signal, channel 1. Maximal input voltage is 1Vpp.

**RGB\_RED2**

This is red input signal, channel 2. Maximal input voltage is 1Vpp.

**RGB\_GREEN1**

This is green input signal, channel 1. Maximal input voltage is 1Vpp.

**RGB\_GREEN2**

This is green input signal, channel 2. Maximal input voltage is 1Vpp.

**RGB\_BLUE1**

This is blue input signal, channel 1. Maximal input voltage is 1Vpp.

**RGB\_BLUE2**

This is blue input signal, channel 2. Maximal input voltage is 1Vpp.

**CVBS/TVG**

Second composite video out / Green component video out. Maximal output voltage is 1Vpp.

**SVC/TVB**

Chrominance video out / Blue component video out. Maximal output voltage is 1Vpp.

**SVY/TVR**

Luminance video out / Red component video out. Maximal output voltage is 1Vpp.

**CVBS**

Composite video out. Maximal output voltage is 1Vpp.

## 6. BIOS-DESCRIPTION

The *ePanel-mgx* is equipped with a KONTRON BIOS (Insyde based) which is located in a Flash-EPROM on board. This device has 8bit wide access. Faster access is provided by shadowing the BIOS to RAM.

### 6.1. The Setup Guide

With the KONTRON BIOS Setup, you can modify BIOS settings and control the special features of the computer. The Setup uses a number of menus for making changes and turning the special features on or off.

#### 6.1.1. General Information

To start the KONTRON BIOS Setup press <F2> when the string `Press <F2> to enter Setup` is displayed during boot up. The main menu will be displayed.

- **The Menu Bar**

The menu bar at the top of the window lists all the different menus. Use the up/down arrows to make a selection.

- **The Legend Bar**

Use the keys listed in the legend bar on the bottom to make your selection or exit the current menu. The table below describes the legend keys and their alternates:

Key	Function
<Esc>	Exit this menu
↑ or ↓ Arrow key	Move cursor up and down
<Enter>	Execute command or select submenu

**To select an item**, simply use the arrow key to move the cursor to the field you want. Then use the Enter key to select a value for that field. The **Save Value and Exit** command in the Exit Menu saves the values currently displayed in all the menus.

**To display a setup menu**, use the arrow keys to move the cursor to the sub menu you want. Then press <Enter>.

## 6.1.2. The Main Menu

You can make the following selections on the Main menu itself. Use the sub menus for other selections.

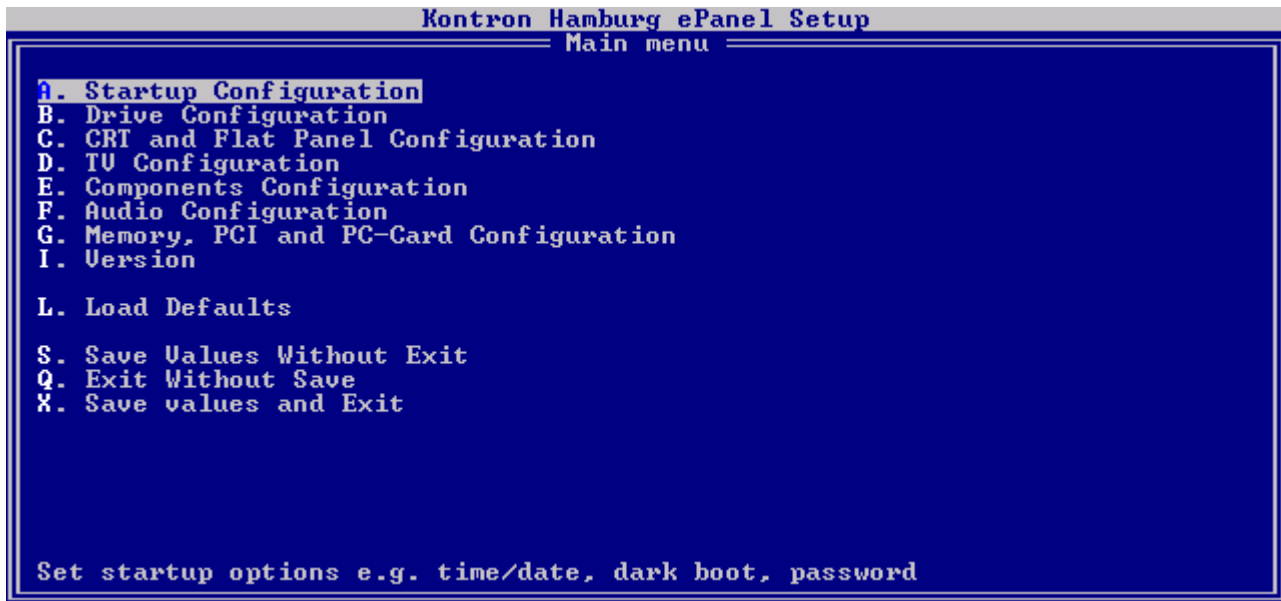

## 6.1.3. Startup Configuration



### 6.1.4. Drive Configuration

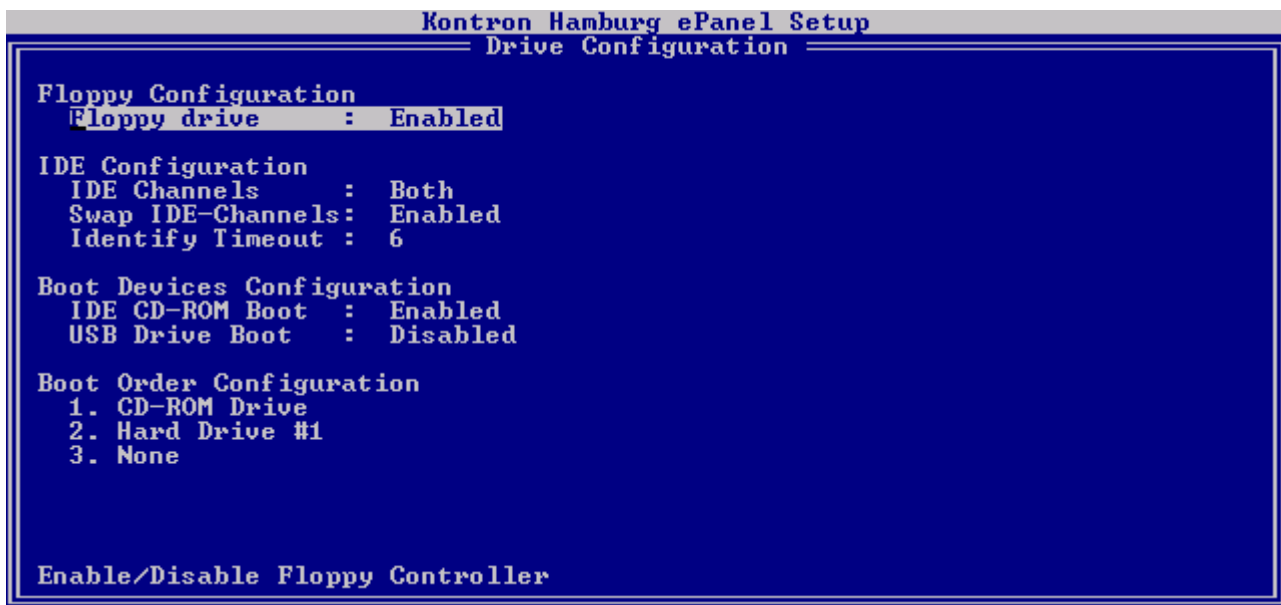

### 6.1.5. CRT and Flatpanel Configuration

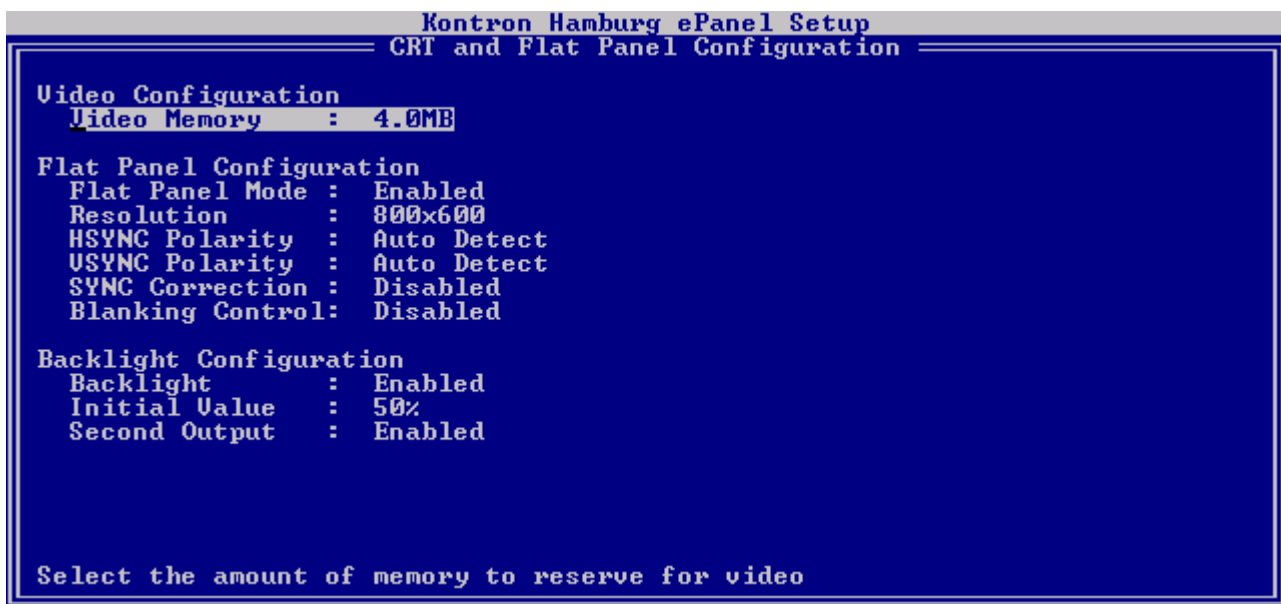

## 6.1.6. TV Configuration

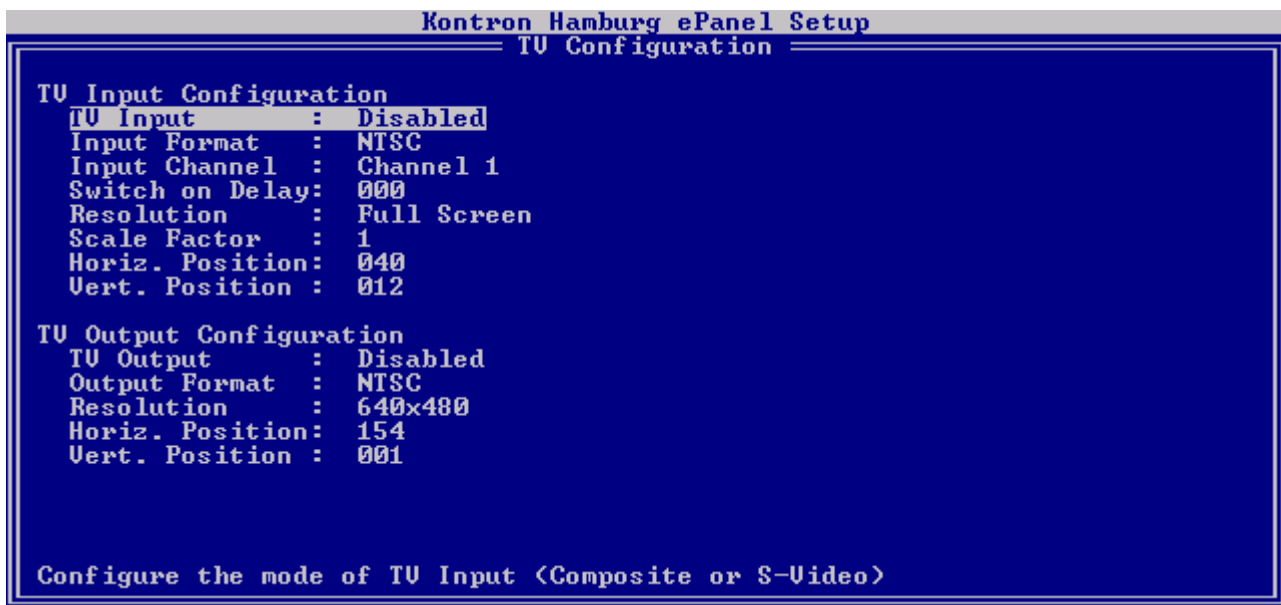

## 6.1.7. Components Configuration

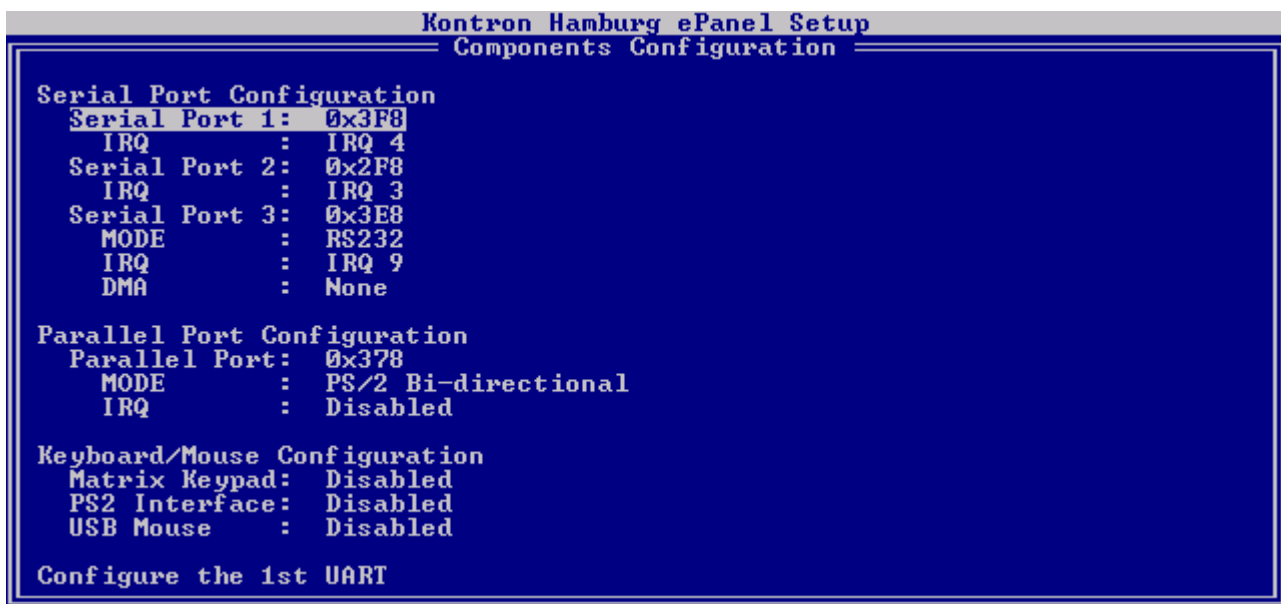

## 6.1.8. Audio Configuration

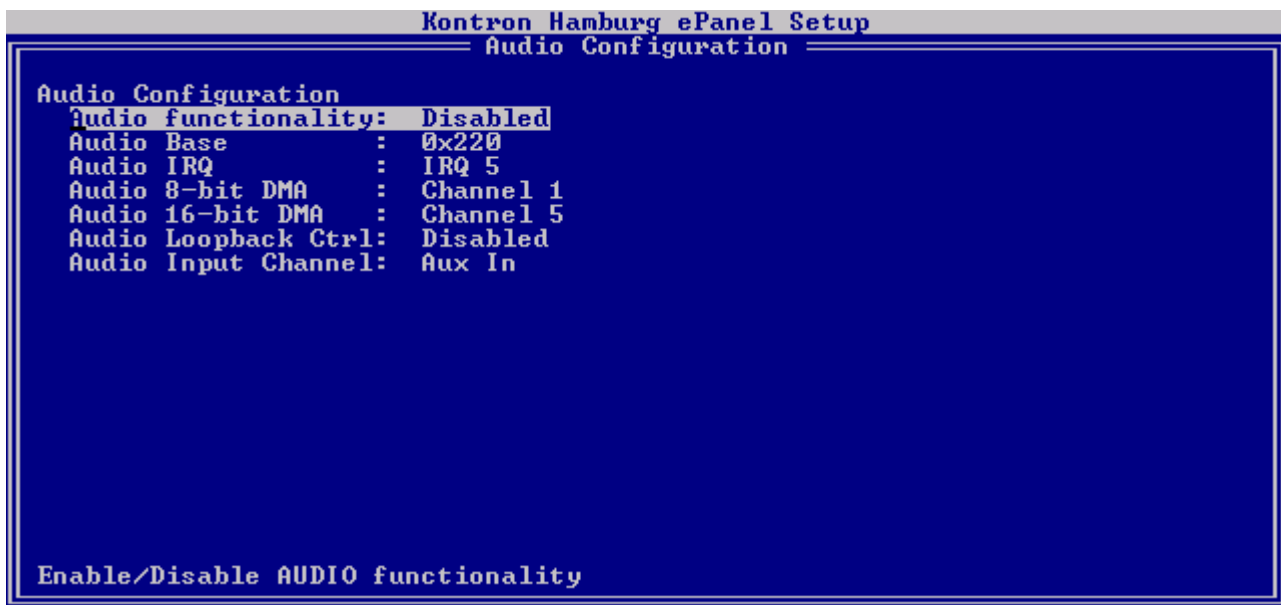

## 6.1.9. Memory, PCI and PC-Card Configuration

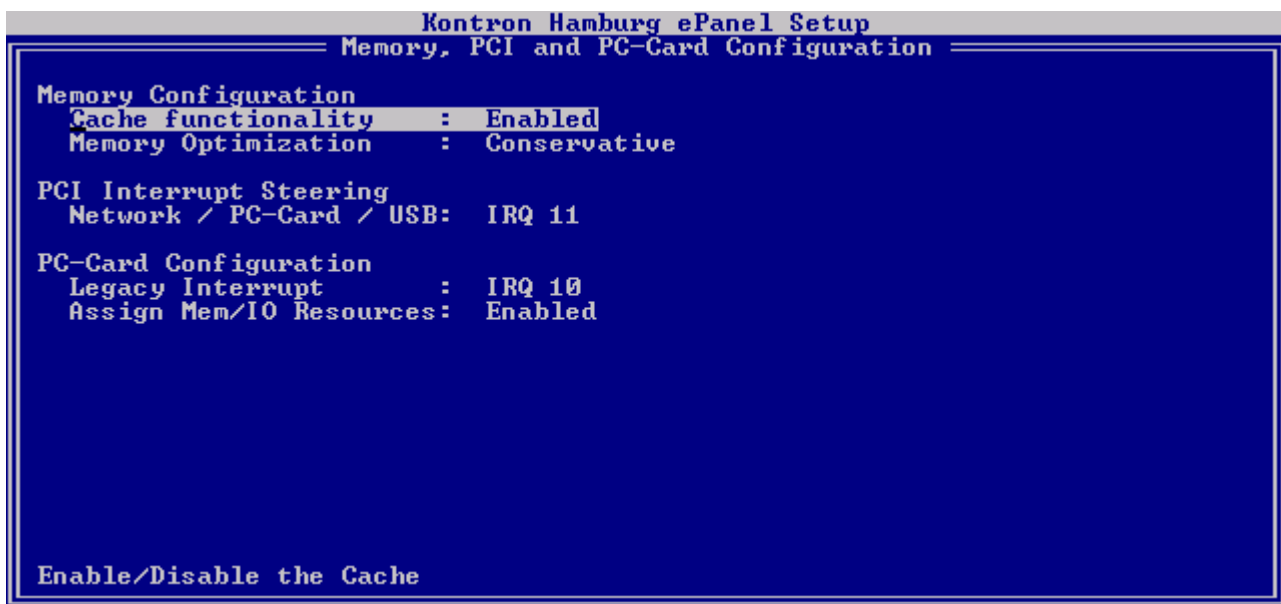

## 6.2. BIOS Update with SC12xUpd.exe

Kontron's **SC12xUpd** gives you the ability to update your BIOS from a floppy disk without having to install a new ROM chip. Kontron's **SC12xUpd** is a utility for „flashing“ a BIOS to the Flash-ROM installed on the **ePanel-mgx**.

Use **SC12xUpd** for the following tasks only:

- Update the current BIOS with a newer version
- Restore a BIOS when it has become corrupted (see below)

Kontron's **SC12xUpd** can be downloaded from the Kontron's web page ( [www.kontron-hh.com](http://www.kontron-hh.com) ).

You can run **SC12xUpd** in following modes:

Usage: **SC12xUpd** [ option ] file

file - image filename  
options:

/B - system BIOS  
/V - video BIOS  
/I - splash image  
/E - erase  
/P - purge CMOS EEPROM  
/C - check/verify  
/R - reboot

/B System-BIOS update  
/V Video-BIOS update. Not available at this time. For future use.  
/I Splash Image update (limited to 192 kByte). File to display custom screen during boot up.  
/E Erase area of Splash-Image.  
/P Erase CMOS values in the flash bios region. Necessary to avoid conflicts during BIOS updates.  
/C Verify BIOS file vs. Flash image for all BIOS images.  
/R Reboot after flash update.

The program may fail if your system is using memory managers. In this case you must disable the memory manager on your system!

---

---

## 7. HARDWARE DESCRIPTION

---

---

### 7.1. GEODE SC1200 Processor

The *ePanel-mgx* Board operates with the National Semiconductor® Geode™ SC1200 processor (with integrated North Bridge and I/O Companion Multi-Function South Bridge ):

#### GEODE SC1200 Processor:

- Supports Intel's MMX instruction set extension for the acceleration of multimedia applications
- 16 kByte unified L1 cache
- PCI Host Controller
- 2D Graphics Accelerator and Display controller
- SDRAM interface tightly coupled to CPU core and graphics subsystem for maximum efficiency
- Provides 16-bit XpressAUDIO subsystem:

#### Integrated South Bridge :

- 3.3V or 5.0V PCI bus compatible
- 5.0V tolerant I/O interfaces
- PCI 2.1 compliant
- Supports PCI initiator-to-ISA and ISA master-to-PCI cycle translations
- PCI master for audio I/O and IDE controllers
- PCI-to-ISA interrupt mapper/translator distributed DMA supported
- Two 8259A-equivalent interrupt controllers
- 8254-equivalent timer
- Two 8237-equivalent DMA controllers
- Boot ROM and keyboard chip select
- Two controllers with support for up to four IDE devices
- Independent timing for master and slave devices for both channels
- PCI bus master burst reads and writes
- AC97 codec interface (Specification Revision 1.3, 2.0, and 2.1 compliant interface)
- Three independent USB interfaces
  - Open Host Controller Interface (OpenHCI) specification compliant
  - Second generation proven core design

#### 7.1.1. **Memory configuration**

The *ePanel-mgx* uses only Small Outline Dual Inline Memory Modules (SO-DIMMs). One socket is available for 3.3V (power level) unbuffered Synchronous Dynamic Random Access Memory (SDRAM) of either 64, 128 or 256 MByte. Specification of the SDRAM module refers to PC-133 standard.

## 7.2. Onboard VGA

The SC1200 incorporates a display subsystem. These include:

- Video Accelerator
  - Buffers and formats input YUV video data from processor
  - 8-bit interface to the GXLV processor
  - X & Y scaler with bilinear filter
  - Color space converter (YUV to RGB)
  
- Video Overlay Logic
  - Color key
  - Data switch for graphics and video data
  
- Gamma RAM
  - Brightness and contrast control
  
- Display Interface
  - Integrated RGB Video DACs
  - VESA DDC2B/DPMS support
  - Flat panel interface

### 7.2.1. Data path of the display subsystem extensions

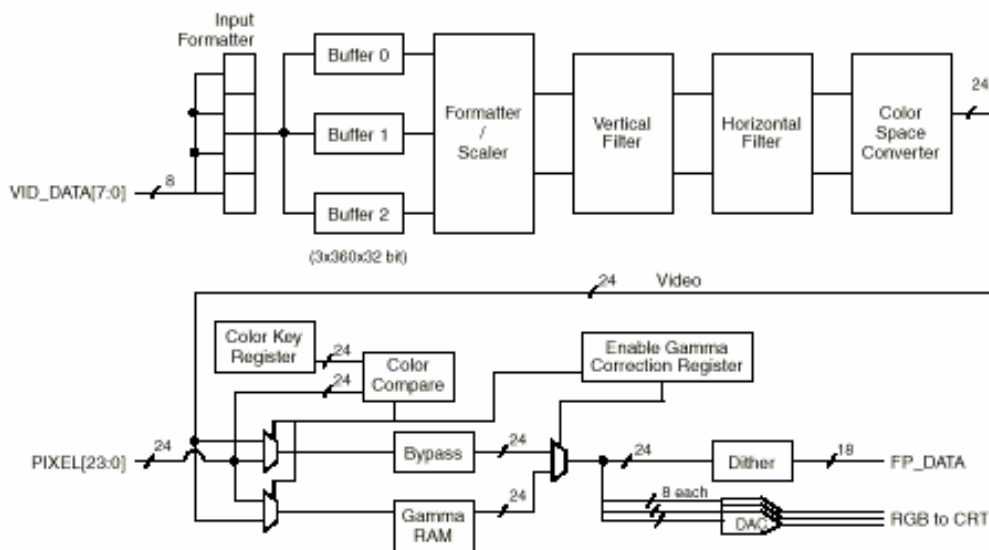

### 7.3. Watchdog

#### Programming:

The system BIOS makes it very easy to use the watchdog. Just activate the Watchdog in the Setup menu and type in the cycle time.

As an additional feature the Watchdog on the **ePanel-mgx** can be triggered in a faster way.

The following sample code describes the procedure for fast Watchdog trigger:

```
#define GEODE_CONFIG_BASE      9000h
#define GEODE_WDTO             0000h
#define GEODE_WDCNFG           0002h
#define WDT_ENABLE             00FCh
#define WDT_DISABLE            0000h
#define WATCHDOG_FREQUENCY    8

int command,
    timeout;

char usage[] = "Usage: SC12xWdt <options> <time>\n"
              "  options:  /A  Activate Watchdog\n"
              "             /D  Delete Watchdog\n"
              "             /R  Reset Watchdog (start new timeout)\n"
              "  <time> :  Timeout in seconds (only /A and /R)\n\n";

void ProcessArgument (int argc, char *argv [])
{
    int cnt, flag = 0;
    char *arg;

    command = 0;
    for (cnt = 1; cnt < argc; cnt++)
    {
        arg = argv [cnt];

        if (*arg == '/')
        {
            for (arg++; *arg; arg++)
            {
                switch (toupper (*arg))
                {
                    case 'A': command = 1;          // Activate
                               break;

                    case 'D': command = 2;          // Delete
                               break;

                    case 'R': command = 3;          // Reset
                               break;

                    default : printf ("Unknown option %s\n\n", arg);
                               printf (usage);
                               exit (EXIT_FAILURE);
                }
            }
        }
        else
        {
            if ((flag++) == 0)
            {
                timeout = atoi (arg);
                timeout *= WATCHDOG_FREQUENCY;
            }
            else
            {
                printf ("Invalid time specification %s\n\n", arg);
                printf (usage);
                exit (EXIT_FAILURE);
            }
        }
    }
}
```

```
if (! command)
{
    printf ("No option specified\n\n");
    printf (usage);
    exit (EXIT_FAILURE);
}
if ((flag != 1) && (command != 2))
{
    printf ("No time specified\n\n");
    printf (usage);
    exit (EXIT_FAILURE);
}
}

void main (int argc, char *argv [])
{
    printf ("Watchdog Utility V1.00\n"
           "(c) 2002 KONTRON Hamburg GmbH\n\n");

    ProcessArgument (argc, argv);
    switch (command)
    {
        case 1: _asm mov dx, GEODE_CONFIG_BASE + GEODE_WDCNFG
                _asm mov ax, WDT_ENABLE
                _asm out dx, ax
                _asm mov dx, GEODE_CONFIG_BASE + GEODE_WDTO
                _asm mov ax, timeout
                _asm out dx, ax
                printf ("Watchdog activating\n");
                break;

        case 2: _asm mov dx, GEODE_CONFIG_BASE + GEODE_WDCNFG
                _asm mov ax, WDT_DISABLE
                _asm out dx, ax
                printf ("Watchdog deleting\n");
                break;

        case 3: _asm mov dx, GEODE_CONFIG_BASE + GEODE_WDTO
                _asm mov ax, timeout
                _asm out dx, ax
                printf ("Watchdog resetting\n");
                break;
    }
}
```

## 7.4. Sound

The codec LM4548 provides the SC1200 audio system with a high quality audio path and all analog functionality. It features full-duplex stereo ADC's and DAC's and an analog mixer with four stereo and three mono inputs. Each input has separate gain, attenuation and mute control.

### Features

- Fully compliant AC97 analog I/O component
- 18bit stereo full-duplex codec
- Programmable independent sample rates from 4kHz to 48kHz
- National 3D sound stereo enhancement
- True line level output with volume control in addition to standard line out
- Stereo input for auxiliary audio

## 7.5. Compact Flash Socket (True IDE compatible)

A Compact Flash socket for commercial CF cards (Type I+II) is already integrated on the module. This socket can serve as boot drive and is not hot-pluggable.

## 7.6. Ethernet 10BASE-T/100BASE-TX LAN

### Overview

The DM9102A is a fully integrated and cost-effective single chip Fast Ethernet NIC controller. It is designed with the low power and high performance process. It is a 3.3V device with 5V tolerance then it supports 3.3V and 5V signaling.

The DM9102A provides direct interface to the PCI-Bus. It supports bus master capability and fully complies with PCI 2.2. In media side, the DM9102A interfaces to the UTP3, 4, 5 in 10Base-T and UTP5 in 100Base-TX. It is fully compliance with the IEEE 802.3u specification. Its auto-negotiation function will automatically configure the DM9102A to take the maximum advantage of its abilities. The DM9102A is also support IEEE 802.3x full-duplex flow control.

### Features

- Integrated Fast Ethernet MAC, Physical Layer and transceiver in one chip
- 128pin QFP / 128pin TQFP with CMOS process
- +3.3V Power supply with +5V tolerant I/O
- Supports PCI interface
- Comply with PCI specification 2.2
- PCI bus master architecture
- EEPROM 93C46 interface supports node ID accesses configuration information and user define message
- Comply with IEEE 802.3u 100Base-TX and 802.3 10Base-T
- Comply with IEEE 802.3u auto-negotiation protocol for automatic link type selection
- Full Duplex/Half Duplex capability
- Support IEEE 802.3x Full Duplex Flow Control
- Digital clock recovery circuit using advanced digital algorithm to reduce jitter
- High performance 100Mbps clock generator and data recovery circuit
- Provides Loopback mode for easy system diagnostics

DAVICOM World Wide Web server

Home: <http://www.davicom.com.tw/>

Drivers: [http://www.davicom.com.tw/download/download\\_driver.asp](http://www.davicom.com.tw/download/download_driver.asp)

## 7.7. Smart Battery Charger

The smart battery charger is a charging circuit that provides the smart battery with charging current and charging voltage to match the smart battery's requested requirements. This allows the battery to control its own charge cycle, thus providing a chemistry independent interface to the battery system. Optionally, the smart battery charger may not allow the smart battery to supply power to the rest of the system when the smart battery is fully charged and the system is connected to AC power thus prolonging the life of the battery. The smart battery charger will also receive critical events from the smart battery when it detects a problem. These include alarms for charging conditions or temperature conditions which exceed the limits set within the particular smart battery. Charging of the battery is independent of state of the CPU, thus allowing the battery to be charged even if the CPU is powered down. Minimum/maximum charging voltage is 8V / 18.4V and minimum/maximum charging current 7mA / 3A. Supply voltage has to be higher as peak charging voltage.

## 7.8. Video Input / Output

The SAA7118E is a combination of a four-channel analog preprocessing circuit including source selection, anti-aliasing filter and ADC, an automatic clamp and gain control, a Clock Generation Circuit (CGC), a digital multi-standard decoder containing two-dimensional chrominance/luminance separation by an adaptive comb filter and a high performance scaler, including variable horizontal and vertical up and downscaling and a brightness, contrast and saturation control circuit. The target application for the SAA7118E is to capture and scale video images, to be provided as digital video stream through the image port of the VGA controller for overlay purposes. Up to 16 CVBS, 8 S-VIDEO or 4 Component inputs are supported. Software control is integrated in the system BIOS and sample applications are available.

## 7.9. Wide range DC Power Supply

The power supply of the board has an input range from 8V to 28V DC. The power supply switches over to battery supply, if the main power supply voltage falls below 8V. All internal supply voltages are generated on board.

## 7.10. PC-Card Interface

The PCI1410A device integrated onboard the **ePanel-mgx** is a high-performance PCI-to-PC Card controller that supports a single PC Card socket compliant with the PC Card Standard. The PC Card Standard retains the 16-bit PC Card specification defined in PCI Local Bus Specification and defines the new 32-bit PC Card, CardBus, as being capable of full 32-bit data transfers at 33 MHz. The PCI1410A device supports both 16-bit and Card- Bus PC Cards, powered at 5V or 3.3V, as required. All card signals are buffered internally to allow hot insertion and removal.

## **7.11. Flatpanel-Interface**

The display controller on the **ePanel-mgx** supports only digital TFT flatpanels from 640 x 480 up to 1024 x 768 pixels and up to 64k colors (16bit). The resolution and the type of flatpanel interface supported can be setup in the BIOS. Please refer to the BIOS section in this manual. Power supply for the Flatpanel can either 3,3V or 5V@800mA typ. (1000mA max.), refer to **8. Jumper settings** how to select Panel\_VCC.

## **7.12. Backlight Control and Power Supply**

A connector (X904) to drive a backlight inverter for flat panels is provided onboard. Power supply for the backlight can be either 5V or 12V@800mA typ. (1000mA max.). A software controlled voltage (0V - 4V) is provided for dimming purposes.

## 8. JUMPER SETTINGS

Inverter Vcc  
J910  
3 - 2 - 1  
12V 5V

Panel Vcc  
J906  
1 - 2 - 3  
5V 3,3V

BLON  
J911  
3 - 2 - 1  
/BLON BLON

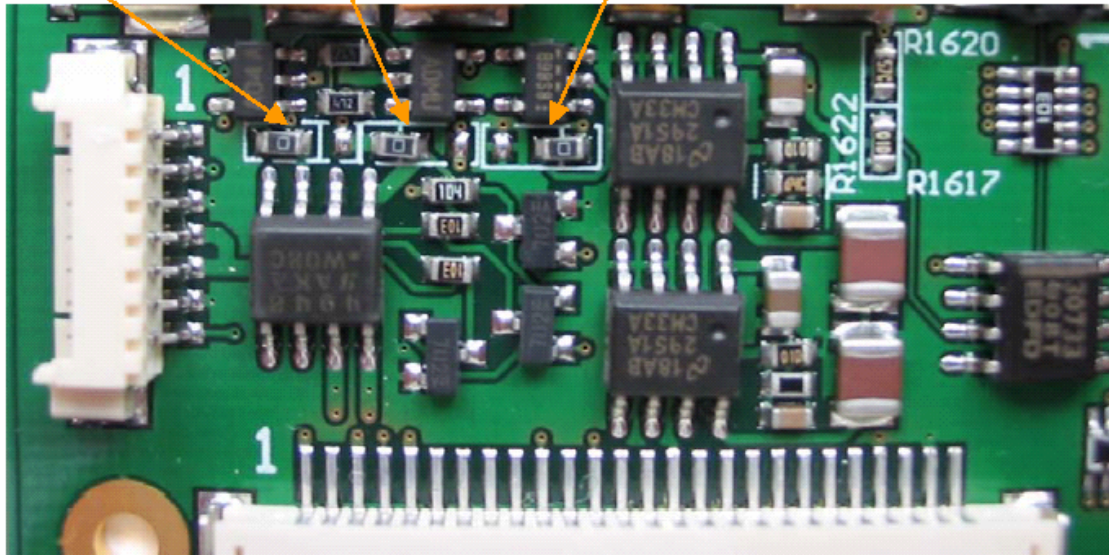

Jumper	FLEX32	Signal	GND	Common	Vcc
J909	Pin30	Left / Right	3	2	1
J908	Pin31	Up / Down	3	2	1
J907	Pin32	VGA / QVGA	3	2	1

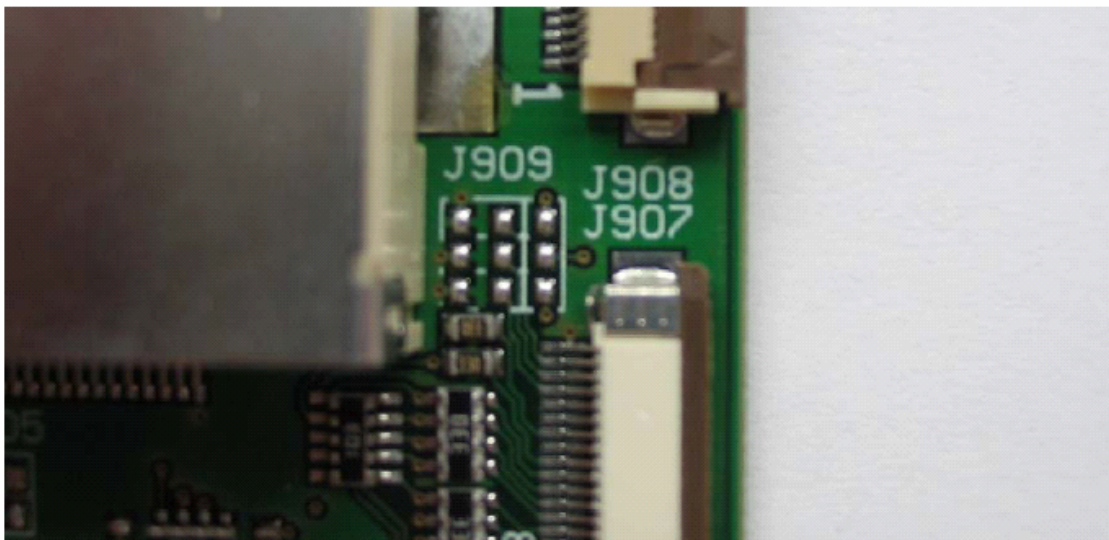

# 9. MECHANICAL DIMENSIONS

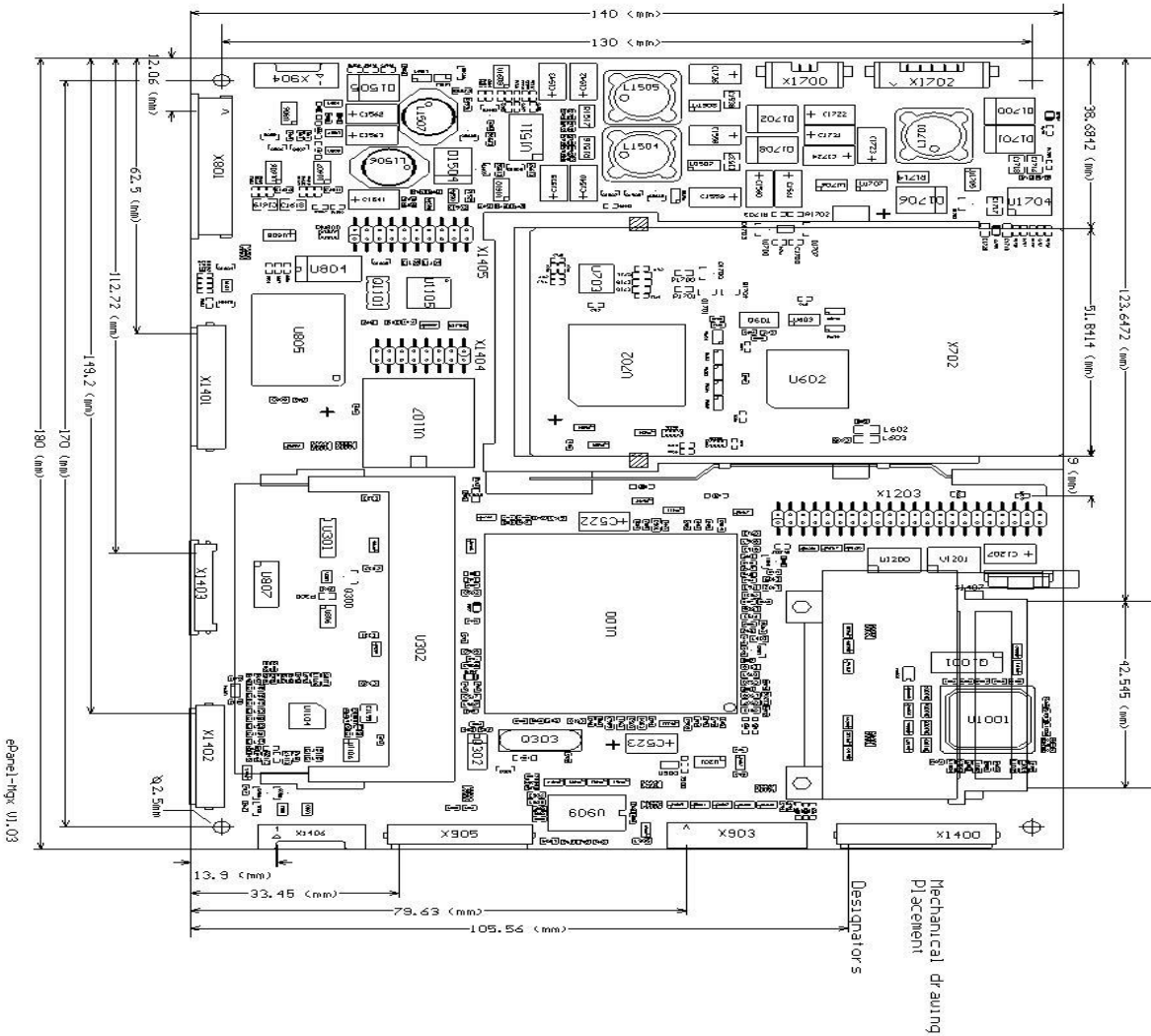

NOTE: all dimensions in mm

## 10. EVALUATION I/O-ADAPTERS

Kontron provides you with the evaluation I/O-adapters which makes all interfaces supported by **ePanel-mgx** easy accessible.

Following interfaces are accessible on **ePanel-ADAPT**:

- Sound output (Stereo)
- Sound input (Stereo)
- Microphone input (Mono)
- Three USB ports
- Printer port LPT1
- VGA CRT
- Two serial ports COM1/COM2 (RS232C)
- Ethernet
- PS/2-Mouse
- PS/2-Keyboard
- IrDA or COM3
- Feature connector with Reset-Input, Power-On-Button
- Backup battery input (3V DC)
- Mechanical dimension: 180,00 x 30,00 mm

The schematics of the I/O-adapter **ePanel-ADAPT** is available as PDF-file on the following support page [www.kontron-hh.com](http://www.kontron-hh.com).

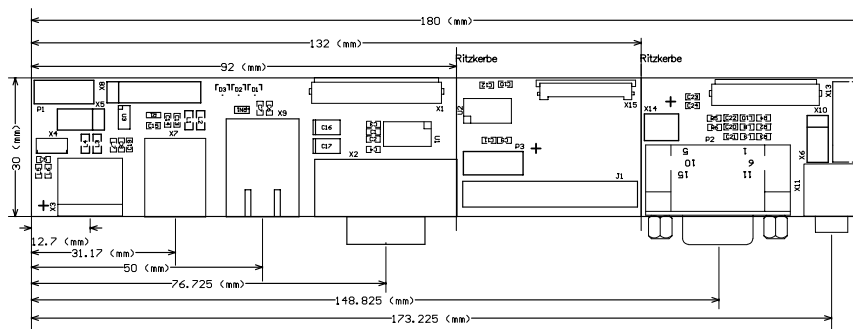



## **11. SPECIFICATIONS**

### **11.1. Mechanical specifications**

Dimensions: 180,0 x 140,0 mm (length x width)  
Height: approx. 10 mm

### **11.2. Electrical specifications**

Supply voltage: 8V DC up to 28V DC  
Supply voltage ripple: 100 mV peak to peak 0 - 20 MHz

Supply current (typical, DOS-Prompt):  
e.g. **ePanel-mgx** 266 MHz + 128 MB SDRAM  
w/o Flatpanel and Backlight Inverter

760mA DC @ 8V  
510mA DC @ 12V  
275mA DC @ 24V

### **11.3. Environmental specifications**

Temperature: operating: +5 °C to +60 °C (\*)  
non operating: -10 °C to +85 °C

National Semiconductor® Geode™ SC1200 Processor is specified for proper operation when case temperature is within the specified range of 0°C to 85°C.

Humidity: operating: 10% to 90% (non-condensing)  
non operating: 5% to 95% (non-condensing)

**(\*) The maximum operating temperature is the maximum measurable temperature on any spot on the modules surface. It is the users responsibility to maintain this temperature within the specification, which is set by the IC manufacturer.**

---

---

## **12. LITERATURE, STANDARDS, LINKS**

---

---

It is not in the responsibility of **Kontron** to supply you with informations about standard PC technology. Please find below a selection of different information sources for your convenience.

### **12.1. ISA-Bus, standard connectors**

- **ISA System Architecture**, Addison-Wesley Publishing Company, ISBN 0-201-40996-8
- **AT BUS Design IEEE P996 Compatible**, Edward Solari, Annabooks San Diego CA. ISBN 0-929392-08-6 [www.annabooks.com](http://www.annabooks.com)
- **PC Handbook, Sixth Edition**, John P. Choisser and John O. Foster, Annabooks San Diego CA. ISBN 0-929392-36-1, [www.annabooks.com](http://www.annabooks.com)
- **AT IBM Technical Reference Vol 1 & 2**, 1985
- **ISA Bus Specifications and Application Notes**, January 30, 1990, Intel
- **Technical Reference Guide, Extended Industry Standard Architecture Expansion Bus**, Compaq 1989
- **Personal Computer Bus Standard P996**, Draft D2.00, January 18, 1990, IEEE Inc
- **Embedded PCs**, Markt&Technik GmbH, ISBN 3-8272-5314-4 (german)

### **12.2. PCI specifications**

- **PCI Special Interest Group**, c/o Intel Corporation
- **PCI System Architecture**, Addison-Wesley Publishing Company, ISBN 0-201-40993-3

### **12.3. RS232C**

- **EIA-232-E Interface between data terminal equipment and data circuit-terminating equipment employing serial binary data interchange (ANSI/IEA-232-D)**

National Semiconductor's Interface Data Book includes several applications notes. These notes are also available online at <http://www.national.com/>. A search engine is provided to search the text of the available application notes. Entering „232“ as search criteria shows you a current list of related application notes.

### **12.4. USB**

The USB specification maybe obtained from the USB Implementers Forum web site at [www.usb.org](http://www.usb.org)

### **12.5. Smart Battery System Specification ( SBS )**

The smart battery system specification maybe obtained from the smart battery system Implementers Forum web site at [www.sbs-forum.org](http://www.sbs-forum.org)

## 13. DOCUMENT REVISION HISTORY

Filename	Date	Edited by	Alteration to previous document revision
ePanel-mgx_M100.DOC	08/21/01	D.Finstel	Initial release
ePanel-mgx_M101.DOC	11/20/01	D.Finstel	Updated Specs
ePanel-mgx_M102.DOC	11/08/02	D.Piper	Updated Logo
ePanel-mgx_M103.DOC	11/28/02	D.Finstel	Prefinal Release
ePanel-mgx_M104.DOC	03/31/04	A.Stauffenberg	Updated Release
ePanel-mgx_M105.DOC	02/21/05	L.Trotter	Updated Specs
ePanel-mgx_M106.DOC	03/21/05	M. Hüttmann	Error correction