

» PowerEngineC7 «

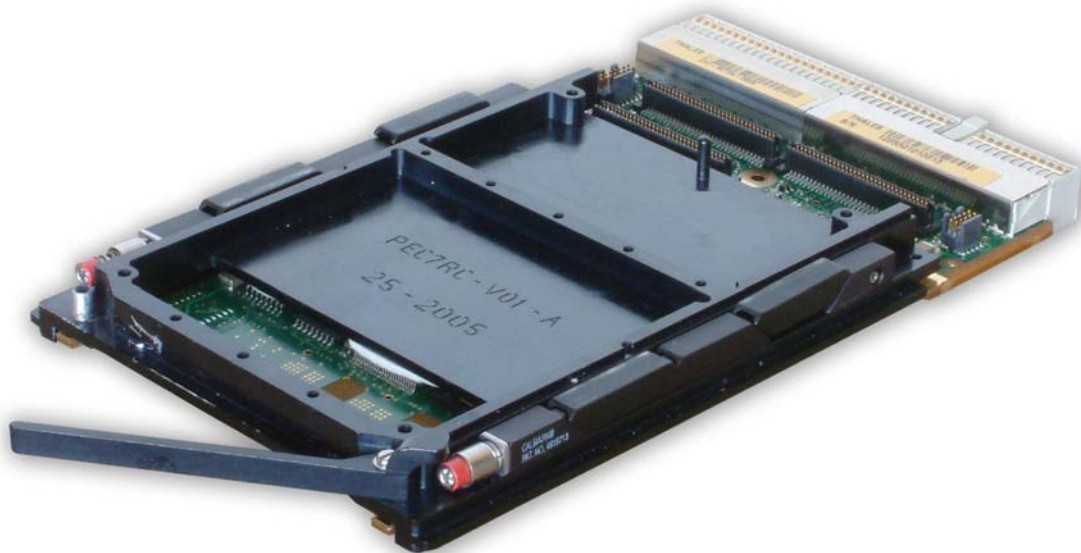

Single PowerPC 750FX User's Guide

CA.DT.A31-5e - February 2013

Revision History

Publication Title:		PowerEngineC7 User's Guide
Doc. ID:		CA.DT.A31-5e
Rev.	Brief Description of Changes	Date of Issue
5e	New Kontron Corporate Design	02-2013

Copyright © 2013 Kontron AG. All rights reserved. All data is for information purposes only and not guaranteed for legal purposes. Information has been carefully checked and is believed to be accurate; however, no responsibility is assumed for inaccuracies. Kontron and the Kontron logo and all other trademarks or registered trademarks are the property of their respective owners and are recognized. Specifications are subject to change without notice.

Proprietary Note

This document contains information proprietary to Kontron. It may not be copied or transmitted by any means, disclosed to others, or stored in any retrieval system or media without the prior written consent of Kontron or one of its authorized agents.

The information contained in this document is, to the best of our knowledge, entirely correct. However, Kontron cannot accept liability for any inaccuracies or the consequences thereof, or for any liability arising from the use or application of any circuit, product, or example shown in this document.

Kontron reserves the right to change, modify, or improve this document or the product described herein, as seen fit by Kontron without further notice.

Trademarks

This document may include names, company logos and trademarks, which are registered trademarks and, therefore, proprietary to their respective owners.

Environmental Protection Statement

This product has been manufactured to satisfy environmental protection requirements where possible. Many of the components used (structural parts, printed circuit boards, connectors, batteries, etc.) are capable of being recycled.

Final disposition of this product after its service life must be accomplished in accordance with applicable country, state, or local laws or regulations.



Environmental protection is a high priority with Kontron.

Kontron follows the DEEE/WEEE directive.

You are encouraged to return our products for proper disposal.

The Waste Electrical and Electronic Equipment (WEEE) Directive aims to:

- > reduce waste arising from electrical and electronic equipment (EEE)
- > make producers of EEE responsible for the environmental impact of their products, especially when they become waste
- > encourage separate collection and subsequent treatment, reuse, recovery, recycling and sound environmental disposal of EEE
- > improve the environmental performance of all those involved during the lifecycle of EEE

Conventions

This guide uses several types of notice: Note, Caution, ESD.



Note: this notice calls attention to important features or instructions.



Caution: this notice alert you to system damage, loss of data, or risk of personal injury.



ESD: This banner indicates an Electrostatic Sensitive Device.

All numbers are expressed in decimal, except addresses and memory or register data, which are expressed in hexadecimal. The prefix `0x` shows a hexadecimal number, following the `C` programming language convention.

The multipliers `k`, `M` and `G` have their conventional scientific and engineering meanings of $*10^3$, $*10^6$ and $*10^9$ respectively. The only exception to this is in the description of the size of memory areas, when `K`, `M` and `G` mean $*2^{10}$, $*2^{20}$ and $*2^{30}$ respectively.



When describing transfer rates, `k` `M` and `G` mean $*10^3$, $*10^6$ and $*10^9$ *not* $*2^{10}$ $*2^{20}$ and $*2^{30}$.

In PowerPC terminology, multiple bit fields are numbered from 0 to n, where 0 is the MSB and n is the LSB. PCI and CompactPCI terminology follows the more familiar convention that bit 0 is the LSB and n is the MSB.

Signal names ending with an asterisk (*) or a hash (#) denote active low signals; all other signals are active high.

Signal names follow the PICMG 2.0 R3.0 CompactPCI Specification and the PCI Local Bus 2.3 Specification.

For Your Safety

Your new Kontron product was developed and tested carefully to provide all features necessary to ensure its compliance with electrical safety requirements. It was also designed for a long fault-free life. However, the life expectancy of your product can be drastically reduced by improper treatment during unpacking and installation. Therefore, in the interest of your own safety and of the correct operation of your new Kontron product, you are requested to conform with the following guidelines.

High Voltage Safety Instructions



Warning!

All operations on this device must be carried out by sufficiently skilled personnel only.



Caution, Electric Shock!

Before installing a not hot-swappable Kontron product into a system always ensure that your mains power is switched off. This applies also to the installation of piggybacks. Serious electrical shock hazards can exist during all installation, repair and maintenance operations with this product. Therefore, always unplug the power cable and any other cables which provide external voltages before performing work.

Special Handling and Unpacking Instructions



ESD Sensitive Device!

Electronic boards and their components are sensitive to static electricity. Therefore, care must be taken during all handling operations and inspections of this product, in order to ensure product integrity at all times

Do not handle this product out of its protective enclosure while it is not used for operational purposes unless it is otherwise protected.

Whenever possible, unpack or pack this product only at EOS/ESD safe work stations. Where a safe work station is not guaranteed, it is important for the user to be electrically discharged before touching the product with his/her hands or tools. This is most easily done by touching a metal part of your system housing.

It is particularly important to observe standard anti-static precautions when changing piggybacks, ROM devices, jumper settings etc. If the product contains batteries for RTC or memory backup, ensure that the board is not placed on conductive surfaces, including anti-static plastics or sponges. They can cause short circuits and damage the batteries or conductive circuits on the board.

General Instructions on Usage

In order to maintain Kontron's product warranty, this product must not be altered or modified in any way. Changes or modifications to the device, which are not explicitly approved by Kontron and described in this manual or received from Kontron's Technical Support as a special handling instruction, will void your warranty.

This device should only be installed in or connected to systems that fulfill all necessary technical and specific environmental requirements. This applies also to the operational temperature range of the specific board version, which must not be exceeded. If batteries are present, their temperature restrictions must be taken into account.

In performing all necessary installation and application operations, please follow only the instructions supplied by the present manual.

Keep all the original packaging material for future storage or warranty shipments. If it is necessary to store or ship the board, please re-pack it as nearly as possible in the manner in which it was delivered.

Special care is necessary when handling or unpacking the product. Please consult the special handling and unpacking instruction on the previous page of this manual.

Table Of Contents

Chapter 1 - Introduction	1
1.1 Objectives	2
1.2 Audience	2
1.3 Scope	2
1.4 Structure	3
1.5 Conventions	4
1.6 Related Documents	5
1.7 World Wide Web Sites	6
Chapter 2 - General Information	7
2.1 Introduction	7
2.2 Main Features	9
2.3 Inputs/Outputs	10
2.4 Operating System Support	10
Chapter 3 - Installation	11
3.1 Safety Requirements	11
3.2 Board Identification	12
Chapter 4 - Functional Description	15
4.1 PowerEngineC7 Block Diagram	15
4.2 General Description	16
4.2.1 Host Bridge	16
4.2.2 Processor	18
4.2.3 Memory	19
4.2.4 PLD Control Register	21
4.2.5 10/100-Mb/s Ethernet Controllers	22
4.2.6 EIA-232 Serial I/O Controller	22
4.2.7 EIA-422/EIA-485 Serial I/O Controller	22
4.2.8 JTAG/Boundary-Scan	23
Chapter 5 - Connectors	24
5.1 J1 Connector Pin Assignment	25
5.2 J2 Connector Pin Assignment	26
5.3 Geographical Address Pin Assignment	27
5.4 PMC Connector Pin Assignment	28

5.4.1	J11 Connector Pin Assignment	28
5.4.2	J12 Connector Pin Assignment	29
5.4.3	J14 Connector Pin Assignment	30
5.5	PCI and Additional CompactPCI Signal Description	31
5.6	Other Signal Description	33
5.7	P3 Connector Pin Assignment	34
5.8	P4 Connector Pin Assignment	36
Chapter 6 -	PMC Site	37
6.1	Description	37
6.2	Signaling Voltage Keying Pin	38
6.3	PMC Installation	39
Chapter 7 -	System Installation	40
7.1	Power Up Specifications	40
7.2	+5V Power Specifications	40
7.3	+3.3V Power Specifications	40
7.4	V(I/O) Power Recommendations	41
7.5	V(I/O) PMC Power Specifications	41
7.6	12V Power Specifications	41
7.7	System Configuration Suggestions	41
Chapter 8 -	Operating Instructions	42
8.1	Power-up	42
8.2	Reset Switch	42
8.3	LEDs	43
8.4	Memory Map	44
8.4.1	System Slot Memory Map Setup by VxWorks	44
8.4.2	Peripheral Slot Memory Map Setup by VxWorks	45
8.5	Hardware Reset	46
8.6	Software Reset	48
8.7	PCI Configuration	48
Chapter 9 -	Inserting and Removing the Board	49
9.1	Inserting the Board	49
9.2	Removing the Board	50
Chapter 10 -	I/O Transition Module	51
10.1	Installing the PowerEngineC7 I/O Transition Module	52

10.2	Reset Switch	52
10.3	Links and GPIOs	53
10.4	Connectors	54
10.4.1	RJ1 Connector Pin Assignment	55
10.4.2	RJ2 Connector Pin Assignment	56
10.4.3	H1 (JTAG_CPCI) Connector Pin Assignment	57
10.4.4	H2 (JTAG_PMC) Connector Pin Assignment	57
10.4.5	H3 (EIA-232) Connector Pin Assignment	58
10.4.6	H4 (EIA-485) Connector Pin Assignment	58
10.4.7	H5 (10/100BASE-T) Connector Pin Assignment (ETH0) H6 (10/100BASE-T) Connector Pin Assignment (ETH1)	59
10.4.8	PMC Connectors Pin Assignment	60
Appendix A - Specifications		62
A.1	Local Resources	62
A.2	Power Requirements	63
A.3	EMC Regulatory Compliance and Safety	63
A.4	Flammability Rating	63
A.5	Environmental Specifications	64
A.5.1	Operating Environment	64
A.5.2	Storage Environment	64
A.6	MTBF Data	65
A.7	Mechanical Construction	66
Appendix B - Troubleshooting		67
B.1	Step 1 - No Power	67
B.2	Step 2 - Power On, Unexpected Behaviour	67
B.3	Step 3 - Power On, No Terminal Display	67
B.4	Step 4 - PowerEngineC7 Locks-up	68
B.5	When Phoning, Faxing or E-Mailing for Technical Support, Be Prepared To Give	68
Glossary		69

List Of Figures

Figure 1: View of the PowerEngineC7	1
Figure 2: Top view of the PowerEngineC7 without the ruggedizer	8
Figure 3: Bottom view of the PowerEngineC7 without the ruggedizer	8
Figure 4: Top Side Identification Labels	12
Figure 5: Bottom Side Identification Labels	13
Figure 6: Ruggedizer Identification Label	14
Figure 7: PowerEngineC7 Block Diagram	15
Figure 8: 10/100-Mb/s Ethernet Controller	22
Figure 9: PowerEngineC7 Onboard Connector Locations	24
Figure 10: COP JTAG Equipment	34
Figure 11: +3.3V PMC	38
Figure 12: Universal PMC	38
Figure 13: PMC Slot	39
Figure 14: LEDs Setting	43
Figure 15: PowerEngineC7 Hardware Reset Block Diagram	46
Figure 16: Inserting the Board	49
Figure 17: Removing the Board	50
Figure 18: PowerEngineC7 I/O Transition Module	51
Figure 19: PowerEngineC7 I/O Transition Module	53
Figure 20: PowerEngineC7 I/O Transition Module Connectors	54
Figure 21: PowerEngineC7 I/O Transition Module Front Panel	54
Figure 22: PowerEngineC7 Dimensions	66

List Of Tables

Table 1: Order Code	7
Table 2: PMC Site Information	37
Table 3: LEDs Description	43
Table 4: PowerEngineC7 System Slot Memory Map Setup by VxWorks	44
Table 5: PowerEngineC7 Peripheral Slot Memory Map Setup by VxWorks	45
Table 6: Reset Generated by the Hard Reset Sources	47
Table 7: PCI0 Accesses	48
Table 8: PCI1 Accesses	48
Table 9: Default Link Settings	53

Chapter 1 - Introduction

The PowerEngineC7 board is the first member of Kontron new family of rugged 3U CompactPCI embedded computers. Designed to meet the requirements of compact, real-time systems for the most demanding defense, aerospace, industrial, transportation and communications applications, the PowerEngineC7 is a result of the combined expertise of Kontron, provider of high-performance, low-power SBCs such as the flagship 6U VME POWERENGINE7, and of the Thales Airborne Systems, provider of airborne mission computers.

The PowerEngineC7 board can be used for applications which require both high computing performance within a restricted dimensional space.

The board is based on the newest member of the Marvell® Discovery™ family of system controllers which interfaces the system bus running at 100 MHz, the DDR SDRAM (Double Data Rate Synchronous RAM) running at 200 MHz, two 32-bit PCI bus and devices such as Ethernet and Serial lines controllers. The board provides main memory of 256 MB of onboard high performance Synchronous DRAM combined with Error Checking and Correcting (ECC) for high system integrity, System Flash, User Flash and nvSRAM RTC.

The PowerEngineC7 can be used both as system slot or peripheral slot processor board.

Its IEEE P1386.1 PMC site allow 32-bit 33/66 MHz PCI operations. A transition module can bring PMC site I/Os to the rear of the system like that both serial lines and Ethernet ports in order to allow I/O access through standard connectors.

The PowerEngineC7 is fully compliant with the ANSI Std 1101.2-1992 and can support Conduction Cooled PCI Mezzanine Card (CCPMC) as described in the VITA 20-199x Draft Standard.

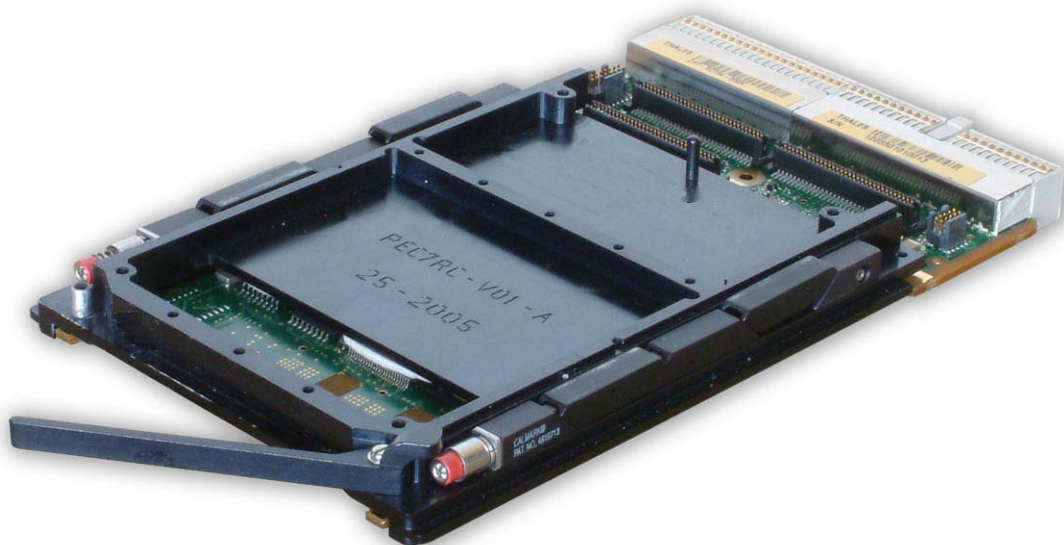

Figure 1: View of the PowerEngineC7

1.1 Objectives

This guide provides general information, hardware preparation and installation instructions, operating instructions and a functional description of the PowerEngineC7 board. The onboard programming, onboard firmware and other software (e.g. drivers and BSPs) are described in detail in separate guides (see section 1.6 “Related Documents”).



As the standard policy for all the Kontron, hardware technical documentation reflects the most recent version of our products. The “Hardware Release Notes” (see section 1.6 “Related Documents”) is to help to keep track of various evolutions that have happened during the early steps of the PowerEngineC7 ramp-up or later in its lifetime.



Functional changes that differ from previous version of the document are identified by a vertical bar in the margin.

1.2 Audience

This guide is written to cover, as far as possible, the range of people who will handle or use the PowerEngineC7, from unpackers/inspectors, through system managers and installation technicians to hardware and software engineers. Most chapters assume a certain amount of knowledge on the subjects of single board computer architecture, interfaces, peripherals, systems, cabling, grounding and communications. There is a glossary provided at the back of this guide that explains some of the terms used and expands all abbreviations.

1.3 Scope

This guide describes all variants of the PowerEngineC7. It does not cover any PMC modules which are described in specific guides (see section 1.6 “Related Documents”).

1.4 Structure

This guide is structured in a way that will reflect the sequence of operations from receipt of the board up to getting it working in your system. Each topic is covered in a separate chapter and each chapter begins with a brief introduction that tells you what the chapter contains. In this way, you can skip any chapters that are not applicable or with which you are already familiar.

The chapters are:

- Chapter 1 - (this chapter) - gives a brief introduction, this guide's objectives and audience, the structure, some warnings, conventions and related documentation.
- Chapter 2 - is PowerEngineC7 general information.
- Chapter 3 - contains unpacking, inspection and identification instructions.
- Chapter 5 - describes the onboard connectors and signals used.
- Chapter 6 - describes the PMC installation.
- Chapter 7 - describes installation of the board in a system.
- Chapter 8 - describes power-up and subsequent operation of the board.
- Chapter 4 - is a functional description.
- Chapter 9 - describes how inserting and removing the board into the backplane.
- Chapter 10 - is a I/O transition module description.
- Appendix A - is a board specification.
- Appendix B - gives troubleshooting guidelines.

There is also a glossary provided at the end of this guide.

1.5 Conventions

This guide uses several types of notice: Note, Caution, ESD.



Note: this notice calls attention to important features or instructions.



Caution: this notice alert you to system damage, loss of data, or risk of personal injury.



ESD: This banner indicates an Electrostatic Sensitive Device.

All numbers are expressed in decimal, except addresses and memory or register data, which are expressed in hexadecimal. The prefix '0x' shows a hexadecimal number, following the 'C' programming language convention.

The multipliers 'k', 'M' and 'G' have their conventional scientific and engineering meanings of $*10^3$, $*10^6$ and $*10^9$ respectively. The only exception to this is in the description of the size of memory areas, when 'K', 'M' and 'G' mean $*2^{10}$, $*2^{20}$ and $*2^{30}$ respectively.



When describing transfer rates, 'k', 'M' and 'G' mean $*10^3$, $*10^6$ and $*10^9$ *not* $*2^{10}$, $*2^{20}$ and $*2^{30}$.

In PowerPC terminology, multiple bit fields are numbered from 0 to n, where 0 is the MSB and n is the LSB. PCI and CompactPCI terminology follows the more familiar convention that bit 0 is the LSB and n is the MSB.

Signal names ending with an asterisk (*) denote active low signals; all other signals are active high.

Signal names ending with a hash (#) denote active low signals; all other signals are active high.

Signal names follow the PICMG 2.0 R3.0 CompactPCI Specification and the PCI Local Bus 2.3 Specification.

1.6 Related Documents

Due to the complexity of some of the devices used on PowerEngineC7, you will need to refer to the following documents for more detailed information.

» Standard

- > PCI Local Bus Specification Revision 3.0, PCI Special Interest Group.
- > IEEE P1386 Common Mezzanine Card Family: CMC.
- > IEEE P1386.1 Physical and Environmental Layers for PCI Mezzanine Cards: PMC.
- > IEEE P1386 Layers for PCI Mezzanine Cards: PMC - Revision 2.2.
- > IEEE Standard for Mechanical Core Specifications for Conduction-Cooled Eurocards, IEEE 1101.2-1992.
- > IEEE Standard Test Access Port and Boundary-Scan Architecture, IEEE 1149.1-2001
- > VITA 32-199x - Processor PMC Standard For Processor PCI Mezzanine Cards [PPMC] - Revision 0.9.
- > Conduction Cooled PCI Mezzanine Card (CCPMC) Specification ANSI/VITA 20-2001 (R2005) February 2005.
- > PICMG 2.0 R3.0 CompactPCI Specification - October 1, 1999.

» Board Components

- > PowerPC 750FX RISC Processor User's Manual, IBM.
- > Marvell Discovery III MV64460 System Controller for PowerPC Processors, Doc. N. MV-S101287-00 Rev. C
January 03 2006.
- > AMD Am79C874 - #22235 Rev. K May 2005.
- > MAXIM MAX3224 15kV ESD-Protected, RS-232 Transceivers with AutoShutdown Plus.
- > MAXIM MAX3491 3.3V-Powered, 10Mbps and Slew-Rate-Limited True RS-485/RS-422 Transceivers.
- > SIMTEK STK17TA8 Data Sheet, September 2005.

» Hardware

- > PowerEngineC7 Boards -Hardware Release Notes, CA.DT.A37

» Software

- > Release Notes BSP Tornado 2.2.1 / VxWorks 5.5.1 for PowerEngineC7, SD.DT.E70

1.7 World Wide Web Sites

Kontron on the world wide web site is available at <http://www.kontron.com>.

Manufacturers of many of the devices used on the PowerEngineC7 maintain world wide web sites. Useful sites:

- > <http://www.picmg.org> PCI Industrial Computer Manufacturers Group.
- > <http://www.chips.ibm.com:80> IBM Semiconductor Solution.
- > <http://www.marvell.com/products> Marvell Communication Controller.
- > <http://www.simtek.com> SIMTEK Corporation.
- > <http://www.altera.com> ALTERA Corporation.

Chapter 2 - General Information

2.1 Introduction

This chapter contains general information for the PowerEngineC7 product. Chapter 4 contains a functional description of the board.

The PowerEngineC7 is a CompactPCI processor card based on the PowerPC G3 750FX (Sahara) RISC CPU which includes 512 KB internal L2 cache and on the Marvel Discovery III MV64460 Integrated System Controller. This product offers an extensive range of standard functions and expansion options including: one processor clocked at 700 MHz, onboard user memory of 256 MB with ECC, onboard one synchronous and one asynchronous serial lines and two 10/100BASE-T Ethernet channels, 64 MB of System Flash memory, 128 MB of User Flash memory, 128 KB of nvSRAM with real-time clock, a 32-bit CompactPCI bus and one 32-bit 33/66 MHz PMC module.

An I/O transition module brings I/O to the rear of the system, especially serial lines and Ethernet ports, in order to allow access of these I/O through connectors.

The PowerEngineC7 is currently only available in Rugged Conduction Cooled build. Nevertheless, a laboratory version is available for development for being used in ambient air cooled chassis. Such a laboratory version is identical to the RC version excepted for the thermal behaviour.

» Order Code

Ordering Information	
3U Compact PCI SBC, PowerPC 750FX @ 700 MHz, 256 MB DDR-SDRAM, 128 KB nvSRAM with RTC, 64 MB System Flash, 128 MB User Flash, Single PMC Slot, Dual Ethernet 10/100, Dual Serial Lines	
Order Code	Description
CP7-RC734-000	RC build, conduction-cooled
CP7-DC734-000	Laboratory ambient-temperature build for development
PB-CP7-000	I/O transition module for I/O routing
COP-PN3-A	COP JTAG cable

Table 1: Order Code

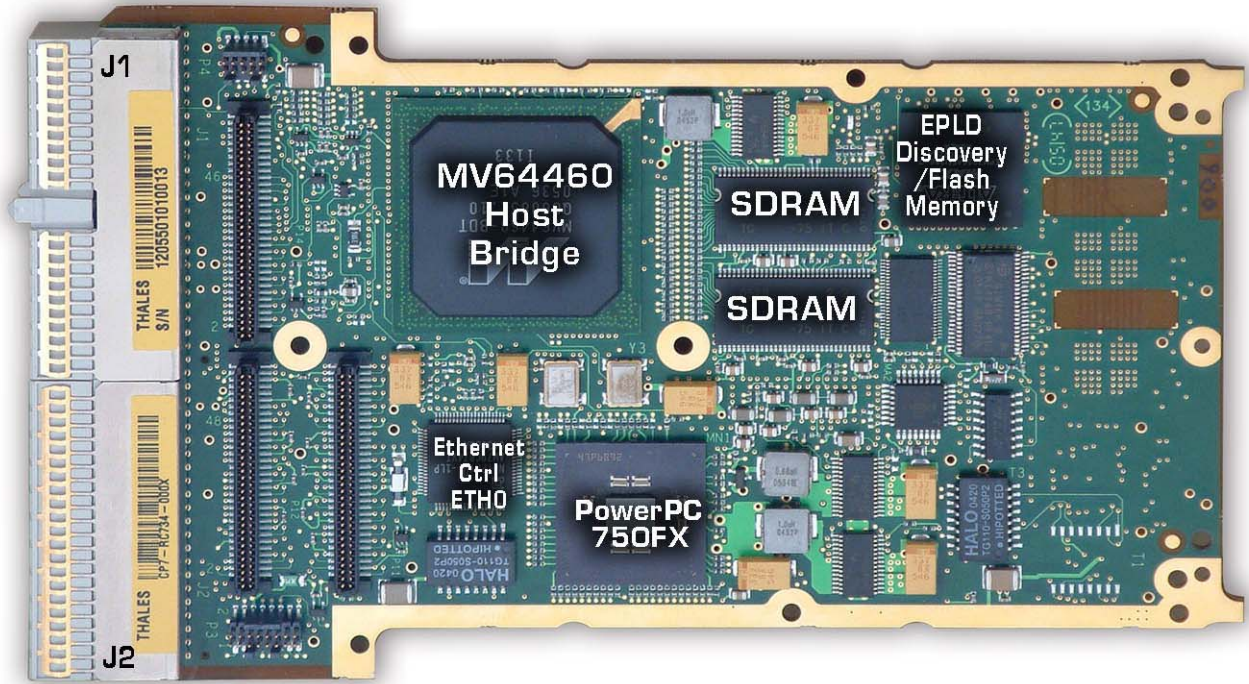

Figure 2: Top view of the PowerEngineC7 without the ruggedizer

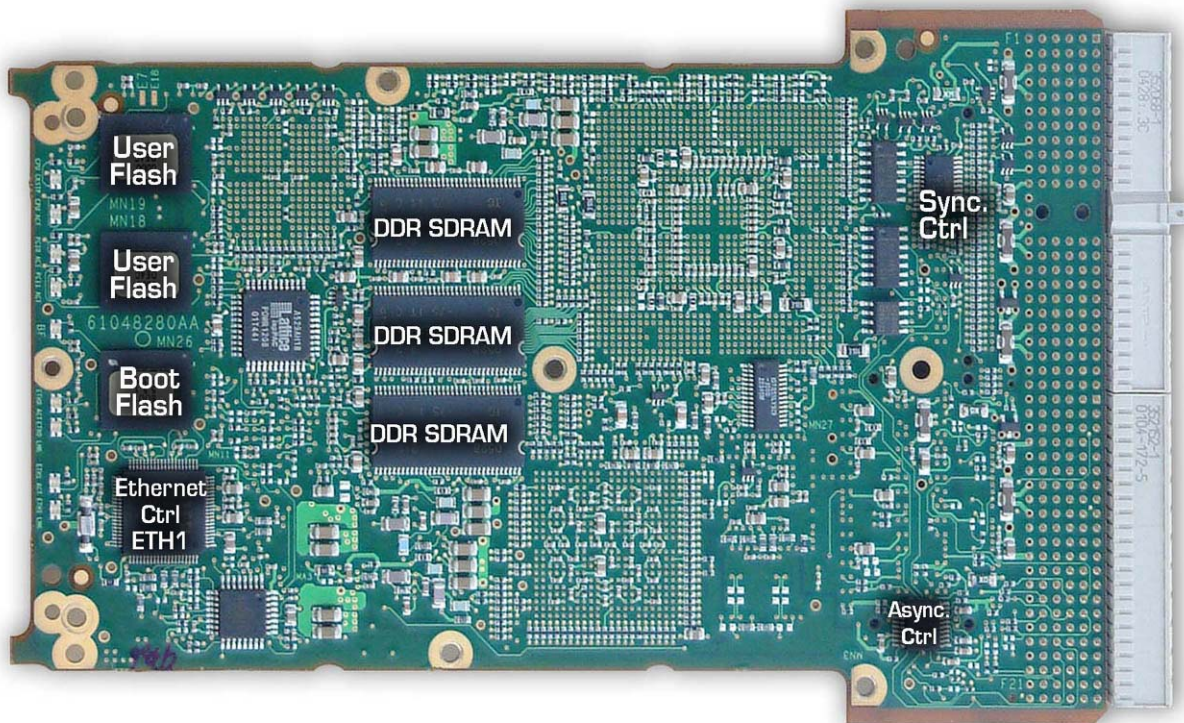

Figure 3: Bottom view of the PowerEngineC7 without the ruggedizer

2.2 Main Features

» PowerPC Processor:

- ▶ One 750FX processor, with 512 KB internal L2 cache, running at 700 MHz.

» Host Bridge:

- ▶ Marvell Discovery III MV64460 Integrated System Controller.

» PCI/PMC extension slots:

- ▶ One 32-bit 33/66 MHz PCI/PMC with a +3.3V PCI bus signaling voltage (V(I/O)) by default.
- ▶ 46 rear I/O issued from J14 connector routed to the backplane on user defined pins of the J2 connector.

» CompactPCI Interface:

- ▶ 32-bit, 33 MHz CompactPCI interface.

» Memory:

- ▶ 256 MB of Double Data Rate Synchronous DRAM (DDR SDRAM) with ECC onboard.
- ▶ 64 MB of System Flash EPROM.
- ▶ 128 MB of User Flash EPROM.
- ▶ 128 KB of nvSRAM with real-time clock.

» Standard Features included:

- ▶ Two Ethernet 10/100BASE-T channels.
- ▶ One EIA-232 simplified asynchronous serial port.
- ▶ One EIA-485/EIA-422 simplified synchronous serial port.

» Software:

- ▶ Board Support Package (BSP) for Tornado 2.2.1/VxWorks 5.5.1.
- ▶ Board Support Package (BSP) for Workbench 2.4/VxWorks 6.2

2.3 Inputs/Outputs

The PowerEngineC7 has a wide variety of possible I/O connectivity including Ethernet, serial ports available on the J2 connector.

- ▶ 46 out of the 64 possible rear user signals defined I/Os signals of the PMC slot,
- ▶ Two 10/100BASE-T Ethernet interfaces (ETH0 and ETH1),
- ▶ One simplified asynchronous serial lines in EIA-232 mode,
- ▶ One simplified synchronous serial line in EIA-485/EIA-422 mode,
- ▶ CPCI and JTAG signals.

For more information about the J2 pin assignment refer to section 5.2 page 26.

The J2 I/Os may be attached by a CompactPCI transition module, refer to Chapter 10 page 51.

2.4 Operating System Support

The Tornado 2.2.1/VxWorks 5.5.1 BSP and Workbench 2.4/VxWorks 6.2 are supported on the PowerEngineC7 as Kontron standard products.

Contact Kontron for more information.

Chapter 3 - Installation

The PowerEngineC7 has been designed for easy installation. However, the following standard precautions, installation procedures, and general information must be observed to ensure proper installation and to preclude damage to the board, other system components, or injury to personnel.

3.1 Safety Requirements

The following safety precautions must be observed when installing or operating the PowerEngineC7. Kontron assumes no responsibility for any damage resulting from failure to comply with these requirements.



Special care should be taken while handling the board: the heat sink can get very hot during operation. Do not touch the heat sink when installing or removing the board.

In addition, the board should not be placed on any surface or in any form of storage container before the board and the heat sink have cooled down to room temperature.



This board contains electrostatically sensitive devices. Please observe the necessary precautions to avoid damage to your board:

Discharge your clothing before touching the assembly. Tools must be discharged before use.

- Do not touch components, connector pins or traces.
- We strongly recommend our customers to work in an environment equipped with anti-static workbenches with professional discharging equipments.

3.2 Board Identification

Kontron PowerEngineC7 boards are identified by labels fitted to the bottom side.

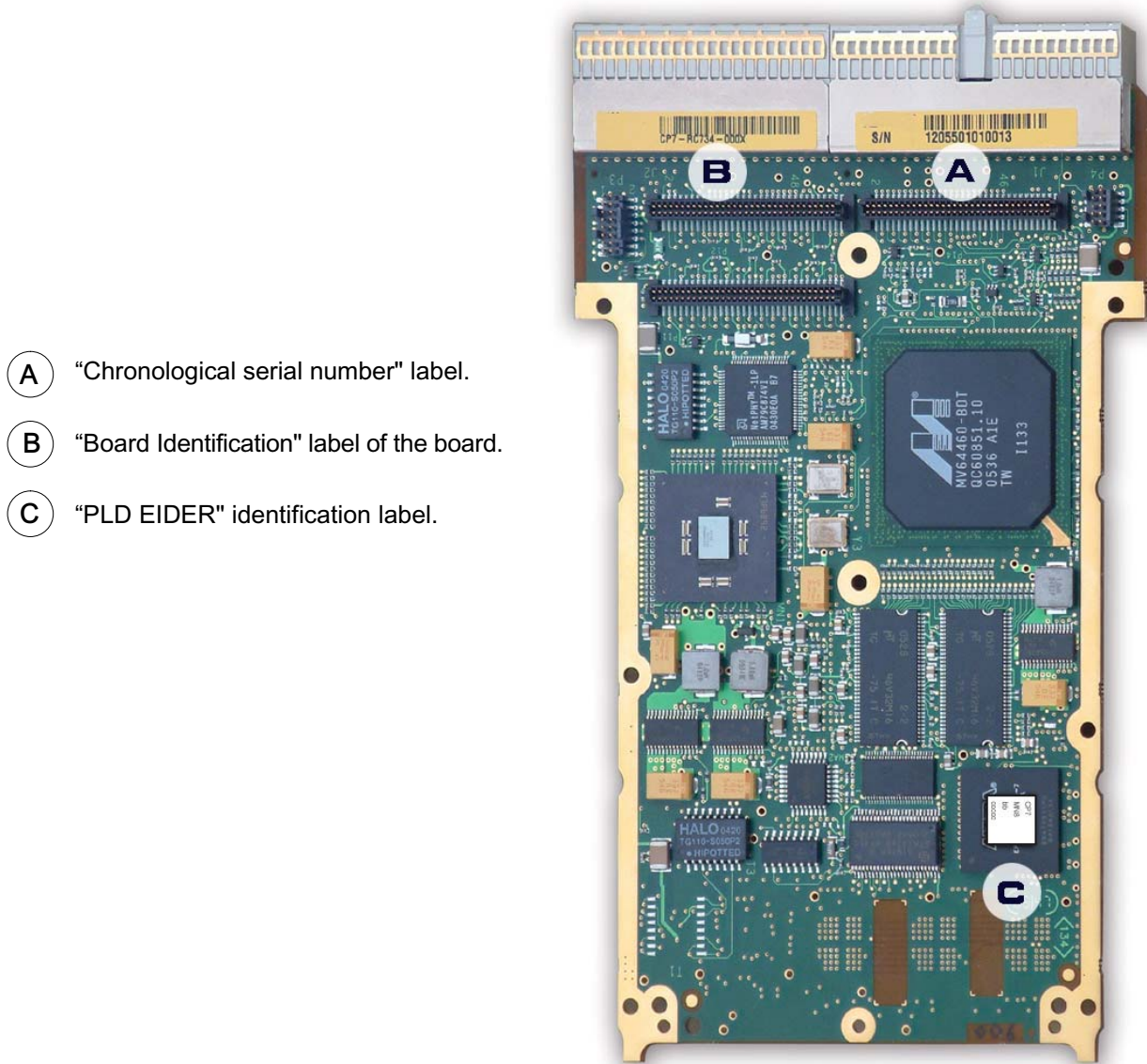

- A** "Chronological serial number" label.
- B** "Board Identification" label of the board.
- C** "PLD EIDER" identification label.

Figure 4: Top Side Identification Labels

- A** "Variant" and "Engineering Change Level" (E.C. Level) label: The "Variant" number is used with the Self-Tests and manufacturing Self-Tests.
- B** "PLD ISPPAC" identification.
- C** "ETH0 Ethernet Number" label. This number is in hexadecimal format.
- D** "ETH1 Ethernet Number" label. This number is in hexadecimal format.
- E** "Boot Flash" identification label.

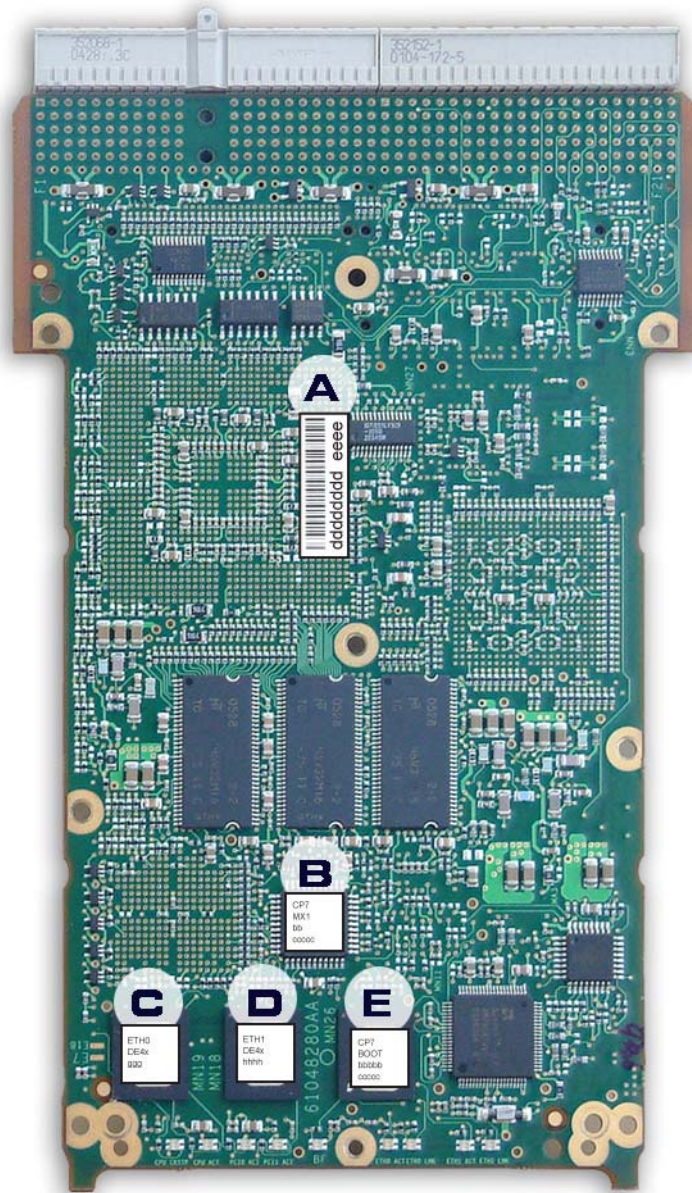

Figure 5: Bottom Side Identification Labels

In addition the ruggedizer is identified by:

AA

"Engineering Change Level" (E.C. Level) label: This is the Engineering Change level of the ruggedizer.

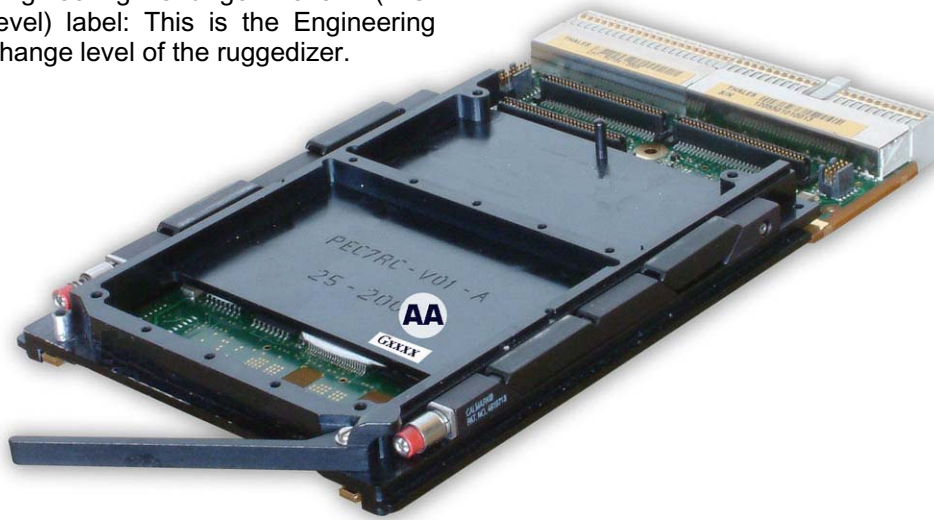

Figure 6: Ruggedizer Identification Label

Chapter 4 - Functional Description

This chapter describes the PowerEngineC7 board at a block diagram level. The general description provides an overview of the PowerEngineC7, followed by a detailed description of several blocks of circuitry.

4.1 PowerEngineC7 Block Diagram

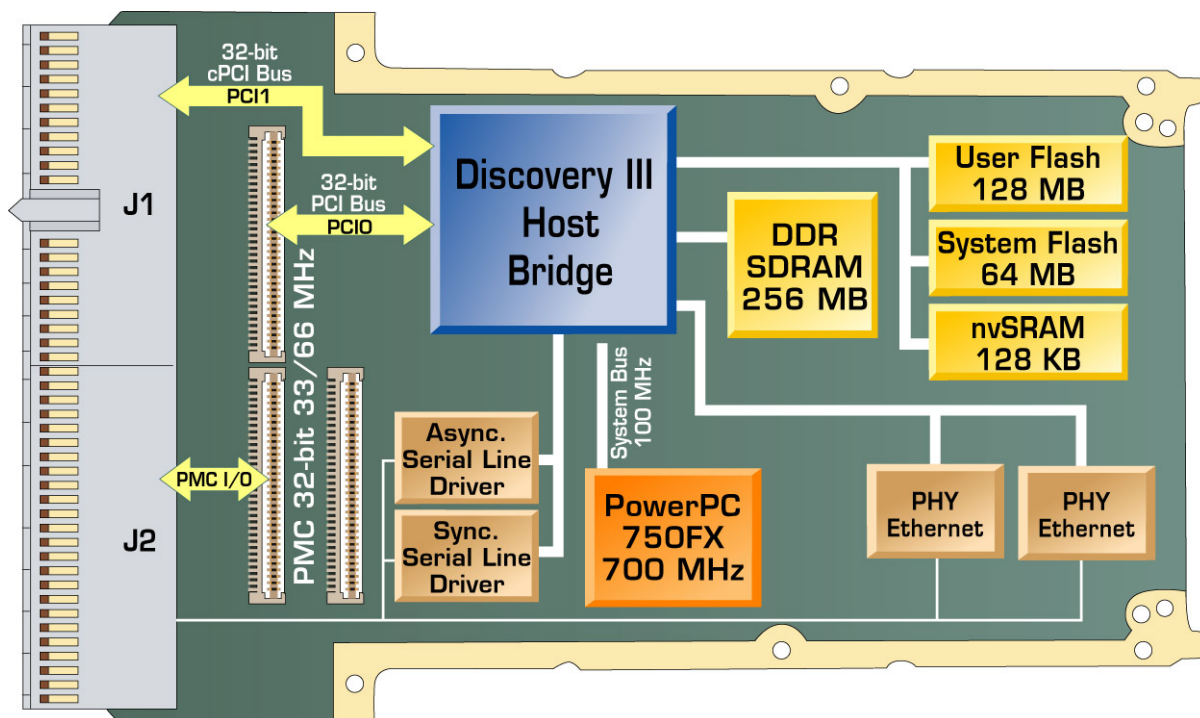

Figure 7: PowerEngineC7 Block Diagram

4.2 General Description

4.2.1 Host Bridge

The MV64460 host bridge is a device developed by Marvell. It provides a single-chip high performance solution for PowerPC CPU based applications, such as routers, web switches, storage applications, wireless infrastructure, and many more.

The MV64460 has a five bus architecture:

- > A 64-bit interface to the CPU bus.
- > A 64-bit interface to DDR SDRAM (Double Data Rate-Synchronous DRAM).
- > A 32-bit interface to devices.
- > Two 64-bit PCI/PCI-X interfaces. On PowerEngineC7 PCI busses are restricted to 32-bit width.

Additionally, the host bridge integrates a 256 KB or 2 Mb SRAM, three Gigabit Ethernet MAC controller, two MPSCs, two XOR DMA engines and four IDMA engines.

» CPU Bus Interface

The MV64460 device supports PowerPC CPUs. With a maximum frequency of 100 MHz (industrial temperature range), the CPU can transfer in excess of 12 Gbps.

It supports:

- > up to 16 pipelined transactions on the CPU bus,
- > PowerPC cache coherency,
- > PowerPC power down CU_QREQn/CPU_QACKn protocol, for single CPU configuration,
- > master capability on the 60x bus,
- > CPU address remapping to the PCI interface,
- > access, write and cache protection, per user specified address range.

» DDR SDRAM Interface

The MV64460 device supports DDR SDRAM (Double Data Rate-Synchronous DRAM). It can run up to 200 MHz with single DRAM load, resulting in 25 Gbps bandwidth.

It is designed for reduced CPU to DRAM access time. It supports DRAM bank interleaving, enabling maximum utilization of the bus. It also supports up to 16 simultaneous opened pages.

The DRAM controller supports all the functionality required for DRAM interface, including DRAM refresh and DRAM initialization sequence.

» Integrated SRAM

The MV64460 integrates 256 KB or 2 Mb of general purpose SRAM. It is accessible from the CPU or any of the other interfaces.

» Flash EEPROM

The PowerEngineC7 board allows the in situ program downloading for programmable components such as System and User Flash.

The host bridge manages all System Flash and local memory through a local bus usually called "device bus". While that bus is address/data multiplexed, an interface is placed between the host bridge and memory components. It allows to manage the interlacing of the local Flash.

Indeed, since "device bus" is limited to 32-bit data width, and as local Flash contains the operational program what is read using 64-bit burst by the processor, the host bridge performs height 32-bit read access, so Flash interlacing allow to reduce time processing.

That interface is integrated into an EPLD which is also used to assume write protection for Boot and local Flash as well Reset management for processor and PCI devices.

» Device Interface

The MV64460 device controller supports different types of memory and I/O devices, such as Flash, ROM,... It support flexible timing parameters, that enables access to slow asynchronous devices. It is a 32-bit wide bus, running at 100 MHz that can be used as a high bandwidth interface to user specific logic.

» PCI/PCI-X Interface

The MV64460 interfaces with two 64-bit PCI/PCI-X busses. On the PowerEngineC7, the busses are restricted to 32-bit width.

These interfaces operate at a maximum frequency of up to 66 MHz in PCI mode. Each PCI interface can act both as a master initiating a PCI bus transaction or as a target responding to a PCI bus transaction.

The MV64460 device PCI interface is fully PCI subclassification rev. 2.2.

The PowerEngineC7 includes a master/slave system slot/peripheral slot CompactPCI interface 32-bit 33 MHz.

When configured as system slot, the PowerEngineC7 provides five PCI clocks configurable to 33 MHz, towards peripheral slots PCI agents.

The PowerEngineC7 has:

- Two CompactPCI connectors (J1 and J2) to allow communication with other CompactPCI boards plugged into the chassis: CompactPCI bus is 32-bit width.
- Three PMC connectors (P11, P12 and P14) to allow communication with compliant PCI Mezzanine Card (PMC) / Conduction Cooled PCI Mezzanine Card (CCPMC): PCI bus is 32-bit width.

» Watchdog Timer

The MV64460 device includes an internal watchdog timer which is a 32-bit count down counter that can be used to generate an non maskable interrupt or reset the system in the vent of unpredictable software behavior.

After the watchdog is enabled, it is a free running counter that needs to be serviced periodically in order to prevent its expiration.

» Timers/Counters

The host bridge contains four 32-bit wide timer/counter.

Each one can be selected to operate as a timer or as a counter; they increment with every clock rising edge.

» DMA Engines

The host bridge has:

- Four IDMA engines: each one has the capability to transfer data between any interface.
- Two XOR DMA engines: each one runs on a linked list of descriptors. It can read from up to eight sources, perform bitwise XOR between the eight sources and writes the result to a destination. Source and destination can reside in any of the MV64460 interfaces.

» Interrupt Controller

The MV64460 device supports up to four interrupt outputs:

- two CPU interrupt pins,
- two open drain CPU interrupt pins.

Each interrupt has its own mask register.

The host bridge MMP lines can also be configured to act as interrupt inputs, enabling registration of external interrupts toward the CPU.

» Ethernet Ports

The MV64460 supports 10/100/1000 Mbps full duplex Ethernet ports which can be configured to 10/100 Mbps MII interface.

» Serial Controllers

The host bridge integrates two Multi-Protocol Serial Controllers (MPSCs) which support UART, HDLC and transparent protocols.

4.2.2 Processor

The IBM PowerPC 750FX is a RISC Microprocessor targeted for high performance, low power systems using a 60x bus. It also includes a 512 KBytes internal L2 cache with onboard Error Correction Circuitry (ECC).

The main features of the PowerPC 750FX processor on the PowerEngineC7 are:

- Superscalar (4 instructions per clock cycle: 2 instructions + Branches).
- Dual 32 KB Instructions and Data non-blocking caches. Dual MMUs.
- Hardware Tablewalk.
- Double precision Floating Point Unique with multiply and add capability.
- 512 KB internal L2 cache controller and 4K-entry tags.
- Dual PLL mode.

Also the PowerPC 750FX has dynamic power management and is a low power static design (NAP Mode)

Refer to the IBM "PowerPC 750FX RISC Processor User's Manual" for further information.

4.2.3 Memory

» SDRAM

256 MB of DDR synchronous DRAM are available on the board including a debrayable ECC/parity checking mechanism. A part of this memory might be protected from PCI and Ethernet access that allow to distinguish a local memory area from an exchange memory area. The memory is organized in a 64-bit size bus plus 8 additional ECC bits, ie 32Mx72 bits size.

That memory supports code execution copied from Flash memory. It gathered local memory and exchange memory.

Local memory area is used to receive all needed data to run the software system and operational application. Exchange memory is dedicated to receive necessary data exchanged between PowerPC and communication devices, ie both PCI busses and Ethernet.

» User Flash EPROM

128 MB of User Flash EPROM is available through two mirror bit 512 Mb, SPANSION S29GL512N10FAI01, located on the bottom side of the board. It is organized into 32-bit interlaced words, the host bridge performs building of 64-bit words.

Write accesses are allowed when the bit 7 (User Flash RyBy) of the PLD Control Register 0 is active (cf. 4.2.4 section: "PLD Control register").

Write permission to the user flash area is governed by the STR1 (PROT_PROG) link (cf. section 10.3 "Links and GPIOs"):

- ▶ STR1 link OUT = User Flash EPROM is write protected,
- ▶ STR1 link IN = User Flash EPROM is write enabled.

This memory is dedicated to store the PowerEngineC7 operational software.

» Non volatile Static Ram

128 KB of non volatile static Ram, with a real-time clock, but without a battery, is available through the Simtek STK17TA8 integrated circuit, located on the bottom side of the board.

The SRAM can be read and written an unlimited number of times, while independant, non volatile data resides in the non volatile elements.



The non volatile static ram has no battery, but has the capacity, when the board is off-line,

- ▶ to initiate a store operation (AutoStore™ Operation) . Refer to the Simtek data sheet for a complete description of this operation.
- ▶ to retain the RT clock information for a short time (less than ten minutes, typical) until the associated capacitor is unloaded.

Write accesses are allowed when the bit 8 (nvSRAM RyBy) of the PLD Control Register 0 is active (cf. 4.2.4 section: "PLD Control register").

The Real-Time Clock function provides an accurate clock with leap year tracking and a programmable, high accuracy oscillator. The Alarm function is programmable for one-time alarms or periodic seconds, minutes, hours, or days. There is also a programmable Watchdog Timer for process control.

» System Flash EPROM

64 MB of System Flash EPROM is available through a 512 Mb, SPANSION S29GL512N10FAI01, located on the bottom side of the board. It is organized into 16-bit non interlaced words, the host bridge performs building of 64-bit words.

This memory, also called `Boot Flash`, is dedicated to store the PowerEngineC7 boot code (firmware and manufacturing tests) and the VxWorks operating system.

Write accesses are allowed when the bit 6 (`Boot Flash RyBy`) of the PLD Control Register 0 is active (cf. 4.2.4 section: "PLD Control register").

Copy for 64 MB data program from System Flash to DDR data memory might be performed within a 1.5s delay.

In current VxWorks implementation, two operating modes are availables:

- ▶ the standard mode,
- ▶ the rescue mode.

The `STR3` link, available on the I/O transition module, allows to switch from one mode to the other (cf. section 10.3 "Links and GPIOs"):

- ▶ `STR3 link OUT` = Standard Mode,
- ▶ `STR3 link IN` = Rescue Mode.

Depending on the selected operating mode, the System Flash EPROM is divided in two specific areas:

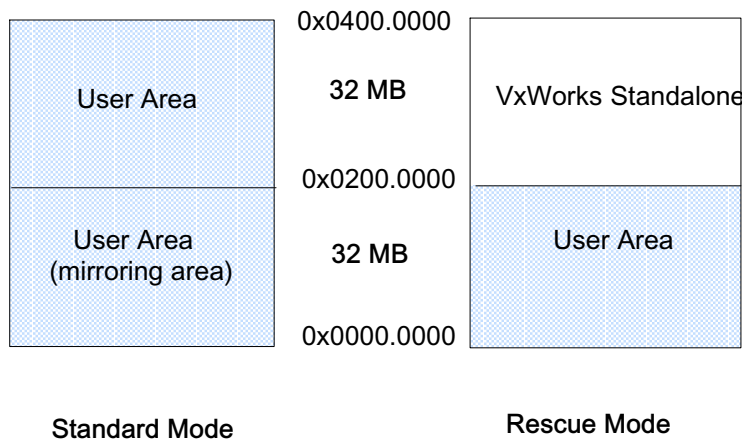

In Standard Mode, the `User Available Area`, is seen twice (mirroring area).

Whatever the mode is (Standard or Rescue), write permission to an accessible system flash area is governed by the `STR2 (PROT_BOOT)` link (cf. section 10.3 "Links and GPIOs"):

- ▶ `STR2 link OUT` = System Flash EPROM is write protected,
- ▶ `STR2 link IN` = System Flash EPROM is write enabled.

In Rescue Mode, the VxWorks standalone kernel provided by Kontron, is used to start up the board. The user is allowed to load its own kernel in the `User Available Area` (32 MB from 0x0000.0000 to 0x0200.0000). Specific VxWorks commands are available to allow the loading of kernel images (cf. `updbootrom` manual page).



Only one PowerEngineC7 board must plugged in the rack when the Rescue mode is used because the CompactPCI discovery phase is not operational when the board is configured in Rescue mode.

4.2.4 PLD Control Register

» PLD Control Register 0 (DevCS[1] - Offset 0x0000)

Bits	Function	Read/Write Init. Value	Description
5:0	PLL_DIVSEL	Read Only	Processor bus ratio: 0x0A = 2 : 1 50MHz 0x1A = 2.667 : 1 66.675MHz 0x05 = 3 : 1 75MHz 0x2A = 3.33 : 1 83.25 MHz 0x00 = 4 : 1 100MHz 0x25 = 5 : 1 125 MHz 0x10 = 5.33 : 1 133.25 MHz 0x20 = 6.667 : 1 166.675 MHz
6	Boot Flash RyBy	Read Only	Status of the Ready Busy Flag of the Boot Flash 0x0 = Busy (device busy with write) 0x1 = Ready (device ready for write)
7	User Flash RyBy	Read Only	Status of the Ready Busy Flag of the User Flash 0x0 = Busy (device busy with write) 0x1 = Ready (device ready for write)
8	nvSRAM RyBy	Read Only	Status of the Ready Busy Flag of the nvSRAM 0x0 = Busy (device busy with write) 0x1 = Ready (device ready for write)
9	J2 pin B4	Read Write 0x1	0x0 = J2 pin B4 is routed to the CPU input signal SMI# 0x1 = J2 pin B4 is not routed anymore to the CPU input signal SMI# and is used to go to the rescue mode. In this case, CPU input signal SMI# is set to 1.
10	NV_INT#	Read Write 0x1	Routing of the NV_INT# signal 0x0 = routed to the CPU input signal SMI# 0x1 = not routed
13:11	Reserved	Read Write 0x7	
14	PCI0 M66EN	Read Write 0x0	PCI0 Bus Frequency 0x0 = 33 MHz 0x1 = 66 MHz
15	Reserved	Read Only	
32:16	Reserved	Read Only 0xffff	

4.2.5 10/100-Mb/s Ethernet Controllers

The Am79C874 NetPHY-1LP device provides the physical (PHY) layer and transceiver functions for one 10/100 Mbps Ethernet port. This device is IEEE 802.3 compliant. It can receive and transmit data reliably at over 300 meters. Interface to the Media Access Controller (MAC) layer is established via the standard Media Independent Interface (MII), a 5-bit symbol interface, or a 7-wire (GPSI) interface. Auto-negotiation determines the network speed and full or half-duplex operations. Automatic polarity correction is performed during auto-negotiation and during 10BASE-T signal reception.

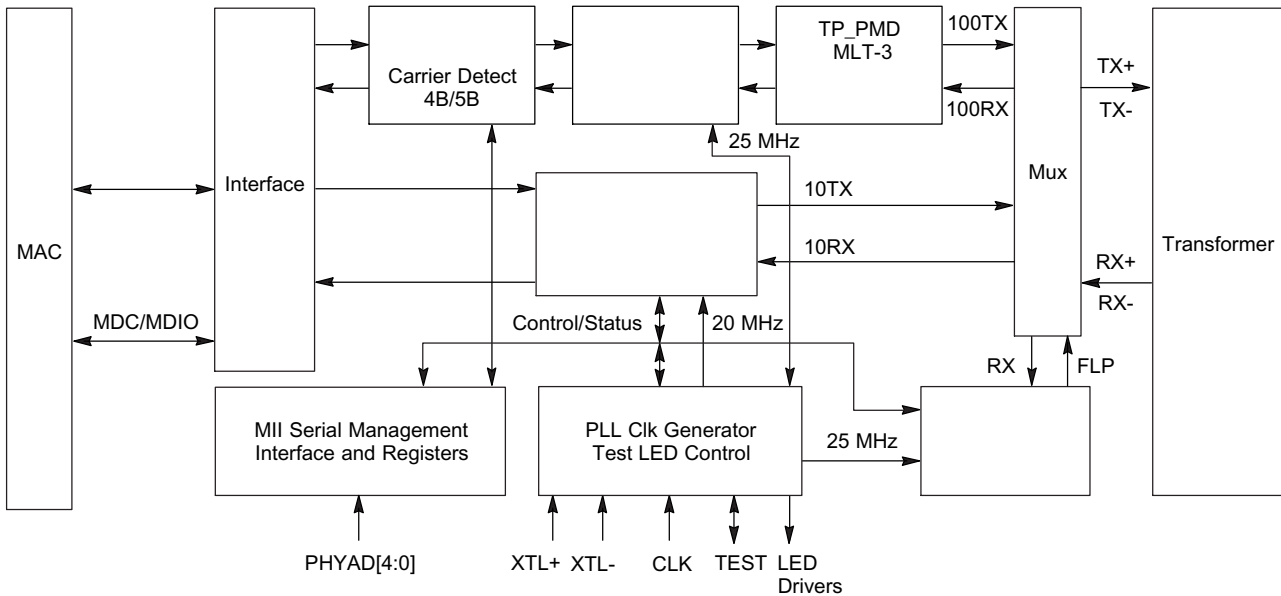

Figure 8: 10/100-Mb/s Ethernet Controller

There are two 10/100 Ethernet controllers onboard handle by the MV64460 host bridge. The 10BASE-T or 100BASE-T interfaces are available via the rear J2 connector.

For each Ethernet controller two LEDs, set on the front of the PowerEngineC7, indicate link detection and data being transmitted. The description of the meaning of these LEDs is given in the section 8.3 "LEDs" page 43.

For detailed programming information, refer to the Am79C874 data sheet.

4.2.6 EIA-232 Serial I/O Controller

The MAX3224E, controlled by the MV64460 host bridge, implements a EIA-232 serial channel.

On PowerEngineC7, the simplified serial port is available (RX and TX) via the rear J2 connector.

4.2.7 EIA-422/EIA-485 Serial I/O Controller

The MAX3491, controlled by the MV64460 host bridge, implements a EIA-422/EIA-485 serial channel.

This controller contains one driver and one receiver. It features full-duplex communication.

There is no termination on the signals of the serial line EIA-422/EIA-485.

On PowerEngineC7, the simplified serial port is available (RX and TX) via the rear J2 connector.

4.2.8 JTAG/Boundary-Scan

There are two JTAG chains available for customer use.

» Chain 1

It includes the Marvell host bridge and the Altera PLD component in following order:

- ▶ Marvell host bridge (MV64460). BSDL associated file available on Marvell web site (refer to section 1.7 "World Web Wide Sites").
- ▶ Altera PLD component (EPM7256AEFI256). BSDL associated file available on Altera web site (refer to section 1.7 "World Web Wide Sites").

Associated signals (TCK/TDI/TDO/TMS/TRST) are routed to the J1 connector. Refer to section 5.1 "J1 Connector Pin Assignment" and section 5.5 "PCI and Additional CompactPCI Signal Description" in chapter "Connectors".

Associated signal are available on the I/O transition module through a standard HE10 connector. Refer to section 10.4.3 "H1 (JTAG_CPCI) Connector Pin Assignment" in chapter "I/O Transition Module".

» Chain 2

It includes the PMC.

Associated signals (JTCK/JTDI/JTDO/JTMS/JTRST) are routed to the J2 connector. Refer to section 5.2 "J2 Connector Pin Assignment", section 5.4 "PMC Connector Pin Assignment" and section 5.6 "Other Signal Description" in chapter "Connectors".

Associated signal are available on the I/O transition module through a standard HE10 connector. Refer to section 10.4.4 "H2 (JTAG_PMC) Connector Pin Assignment" in chapter "I/O Transition Module".

Chapter 5 - Connectors

This chapter gives the pin assignment and signal descriptions for the PowerEngineC7 onboard connectors:

- J1 and J2 rear panel connectors,
- J11, J12 and J14 PMC connectors,
- P3 and P4 connectors.

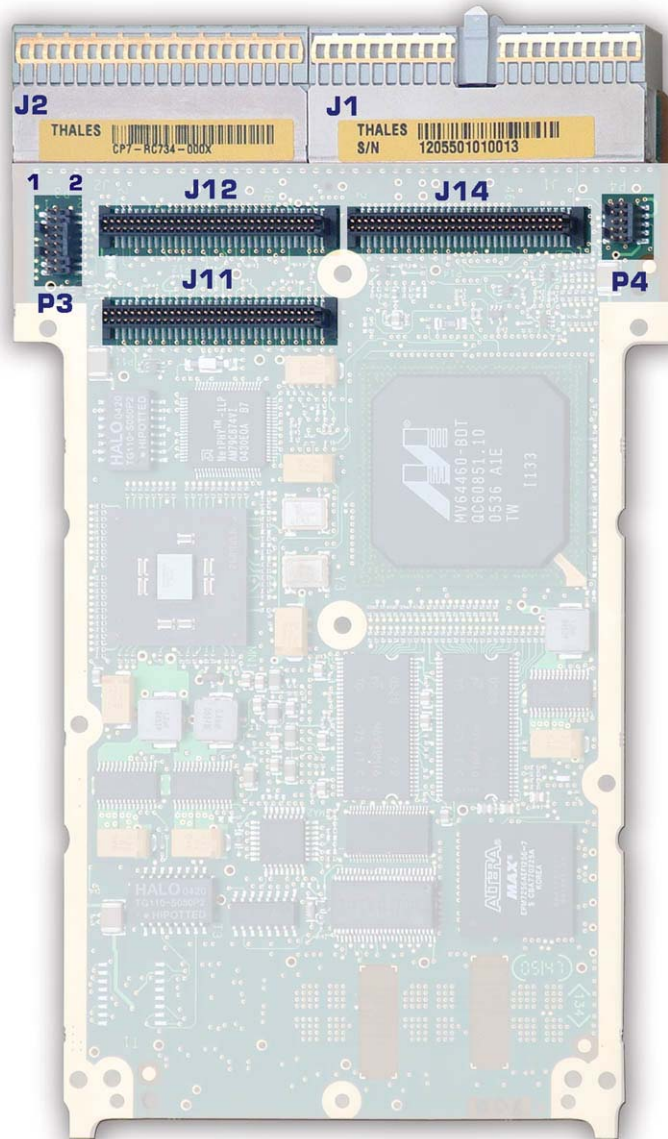

Figure 9: PowerEngineC7 Onboard Connector Locations

5.1 J1 Connector Pin Assignment

Pin Number	J1 Connector					
	Row A Signal	Row B Signal	Row C Signal	Row D Signal	Row E Signal	Row F Signal
25	+5V	REQ64#	N.C.	+3.3V	+5V	GND
24	AD[1]	+5V	V(I/O)	AD[0]	ACK64#	GND
23	+3.3V	AD[4]	AD[3]	+5V	AD[2]	GND
22	AD[7]	GND	+3.3V	AD[6]	AD[5]	GND
21	+3.3V	AD[9]	AD[8]	M66EN	C/BE[0]#	GND
20	AD[12]	GND	V(I/O)	AD[11]	AD[10]	GND
19	+3.3V	AD[15]	AD[14]	GND	AD[13]	GND
18	SERR#	GND	+3.3V	PAR	C/BE[1]#	GND
17	+3.3V	N.C.	N.C.	GND	PERR#	GND
16	DEVSEL#	GND	V(I/O)	STOP#	N.C.	GND
15	+3.3V	FRAME#	IRDY#	GND	TRDY#	GND
12-14	KEY AREA					
11	AD[18]	AD[17]	AD[16]	GND	C/BE[2]#	GND
10	AD[21]	GND	+3.3V	AD[20]	AD[19]	GND
9	C/BE[3]#	IDSEL	AD[23]	GND	AD[22]	GND
8	AD[26]	GND	V(I/O)	AD[25]	AD[24]	GND
7	AD[30]	AD[29]	AD[28]	GND	AD[27]	GND
6	REQ[0]#	GND	+3.3V	CLK[0]	AD[31]	GND
5	N.C.	N.C.	RST#	GND	GNT[0]#	GND
4	N.C.	GND	V(I/O)	N.C.	N.C.	GND
3	INTA#	INTB#	INTC#	+5V	INTD#	GND
2	TCK	+5V	TMS	TDO	TDI	GND
1	+5V	-12V	TRST#	+12V	+5V	GND

PCI or additional CompactPCI signals active when low.

For more information about PCI and additional CompactPCI signals, refer to section 5.5 page 31. The other signals are described in section 5.6 page 33.

5.2 J2 Connector Pin Assignment

Pin Number	J2 Connector					
	Row A Signal	Row B Signal	Row C Signal	Row D Signal	Row E Signal	Row F Signal
22	GA[4]	GA[3]	GA[2]	GA[1]	GA[0]	GND
21	CLK[6]	GND	ETH0_TX-	RS232_TX	JTCK	GND
20	CLK[5]	GND	ETH0_TX+	RS232_RX	JTMS	GND
19	GND	GND	ETH0_RX+	RS485_RCX+	JTDO	GND
18	ETH1_RX+	GPIO[1]	ETH0_RX-	RS485_RCX-	JTRST	GND
17	ETH1_RX-	PROT_BOOT	RST_BP#	N.C.	GNT[6]# pullup to +3V3	GND
16	ETH1_TX-	GPIO[0]	DEGXB	GND	BF_OUT	GND
15	ETH1_TX+	PROT_PROG	FALXB	N.C.	GNT[5]# pullup to +3V3	GND
14	JTDI	RS485_TCX-	RS485_TCX+	RS485_TX-	RS485_TX+	GND
13	PMCIO[5]	PMCIO[4]	PMCIO[3]	PMCIO[2]	PMCIO[1]	GND
12	PMCIO[10]	PMCIO[9]	PMCIO[8]	PMCIO[7]	PMCIO[6]	GND
11	PMCIO[15]	PMCIO[14]	PMCIO[13]	PMCIO[12]	PMCIO[11]	GND
10	PMCIO[20]	PMCIO[19]	PMCIO[18]	PMCIO[17]	PMCIO[16]	GND
9	PMCIO[25]	PMCIO[24]	PMCIO[23]	PMCIO[22]	PMCIO[21]	GND
8	PMCIO[30]	PMCIO[29]	PMCIO[28]	PMCIO[27]	PMCIO[26]	GND
7	PMCIO[35]	PMCIO[34]	PMCIO[33]	PMCIO[32]	PMCIO[31]	GND
6	PMCIO[40]	PMCIO[39]	PMCIO[38]	PMCIO[37]	PMCIO[36]	GND
5	PMCIO[45]	PMCIO[44]	PMCIO[43]	PMCIO[42]	PMCIO[41]	GND
4	V(I/O)	SMI# ⁽¹⁾	RS485_RX-	RS485_RX+	PMCIO[46]	GND
3	CLK[4]	GND	GNT[3]#	N.C.	GNT[4]# pullup to +3V3	GND
2	CLK[2]	CLK[3]	SYSEN#	GNT[2]#	REQ[3]#	GND
1	CLK[1]	GND	REQ[1]#	GNT[1]#	REQ[2]#	GND

: PCI and additional CompactPCI signals active when low.

(1) : Depend on the value of the bit 9 of the PLD Control Register 0. Refer to section 4.2.4 "PLD Control Register" page 21 for a detailed description of the PLD Control Register.

For more information about PCI and additional CompactPCI signals, refer to section 5.5 page 31. The other signals are described in section 5.6 page 33.

5.3 Geographical Address Pin Assignment

Table below illustrates the physical slot number and its physical slot address defined by GA[4...0]. Geographical address 31 is the default address that results when a geographical address capable board is installed in a backplane slot that does not support geographical addressing.

Physical Slot Number	GA[4] Pin	GA[3] Pin	GA[2] Pin	GA[1] Pin	GA[0] Pin
0	GND	GND	GND	GND	GND
1	GND	GND	GND	GND	Open
2	GND	GND	GND	Open	GND
3	GND	GND	GND	Open	Open
4	GND	GND	Open	GND	GND
5	GND	GND	Open	GND	Open
6	GND	GND	Open	Open	GND
7	GND	GND	Open	Open	Open
8	GND	Open	GND	GND	GND
9	GND	Open	GND	GND	Open
10	GND	Open	GND	Open	GND
11	GND	Open	GND	Open	Open
12	GND	Open	Open	GND	GND
13	GND	Open	Open	GND	Open
14	GND	Open	Open	Open	GND
15	GND	Open	Open	Open	Open
16	Open	GND	GND	GND	GND
17	Open	GND	GND	GND	Open
18	Open	GND	GND	Open	GND
19	Open	GND	GND	Open	Open
20	Open	GND	Open	GND	GND
21	Open	GND	Open	GND	Open
22	Open	GND	Open	Open	GND
23	Open	GND	Open	Open	Open
24	Open	Open	GND	GND	GND
25	Open	Open	GND	GND	Open
26	Open	Open	GND	Open	GND
27	Open	Open	GND	Open	Open
28	Open	Open	Open	GND	GND
29	Open	Open	Open	GND	Open
30	Open	Open	Open	Open	GND
31	Open	Open	Open	Open	Open

5.4 PMC Connector Pin Assignment

5.4.1 J11 Connector Pin Assignment

Pin	Signal
1	JTCK
3	GND
5	INTB#
7	BUSMODE#1
9	INTD#
11	GND
13	CLK
15	GND
17	REQ#
19	V(I/O)
21	AD[28]
23	AD[25]
25	GND
27	AD[22]
29	AD[19]
31	V(I/O)
33	FRAME#
35	GND
37	DEVSEL#
39	GND
41	N.C.
43	PAR
45	V(I/O)
47	AD[12]
49	AD[09]
51	GND
53	AD[06]
55	AD[04]
57	V(I/O)
59	AD[02]
61	AD[00]
63	GND

Pin	Signal
2	-12V
4	INTA#
6	INTC#
8	+5V
10	N.C.
12	N.C.
14	GND
16	GNT#
18	+5V
20	AD[31]
22	AD[27]
24	GND
26	C/BE[3]#
28	AD[21]
30	+5V
32	AD[17]
34	GND
36	IRDY#
38	+5V
40	LOCK#
42	N.C.
44	GND
46	AD[15]
48	AD[11]
50	+5V
52	C/BE[0]#
54	AD[05]
56	GND
58	AD[03]
60	AD[01]
62	+5V
64	REQ64#

PCI signals active when low.

5.4.2 J12 Connector Pin Assignment

Pin	Signal
1	+12V
3	JTMS
5	JTDI
7	GND
9	N.C.
11	BUSMODE#2
13	RST#
15	+3.3V
17	N.C.
19	AD[30]
21	GND
23	AD[24]
25	IDSEL
27	+3.3V
29	AD[18]
31	AD[16]
33	GND
35	TRDY#
37	GND
39	PERR#
41	+3.3V
43	C/BE[1]#
45	AD[14]
47	M66EN
49	AD[08]
51	AD[07]
53	+3.3V
55	N.C.
57	N.C.
59	GND
61	ACK64#
63	GND

Pin	Signal
2	JTRST#
4	JTDO
6	GND
8	N.C.
10	N.C.
12	+3.3V
14	BUSMODE#3
16	BUSMODE#4
18	GND
20	AD[29]
22	AD[26]
24	+3.3V
26	AD[23]
28	AD[20]
30	GND
32	C/BE[2]#
34	N.C.
36	+3.3V
38	STOP#
40	GND
42	SERR#
44	GND
46	AD[13]
48	AD[10]
50	+3.3V
52	N.C.
54	N.C.
56	GND
58	N.C.
60	N.C.
62	+3.3V
64	N.C.

: PCI signals active when low.

For more information about PCI signals, refer to section 5.5 page 31.

5.4.3 J14 Connector Pin Assignment

Pin	Signal
1	PMCIO[1]
3	PMCIO[3]
5	PMCIO[5]
7	PMCIO[7]
9	PMCIO[9]
11	PMCIO[11]
13	PMCIO[13]
15	PMCIO[15]
17	PMCIO[17]
19	PMCIO[19]
21	PMCIO[21]
23	PMCIO[23]
25	PMCIO[25]
27	PMCIO[27]
29	PMCIO[29]
31	PMCIO[31]
33	PMCIO[33]
35	PMCIO[35]
37	PMCIO[37]
39	PMCIO[39]
41	PMCIO[41]
43	PMCIO[43]
45	PMCIO[45]
47	N.C.
49	N.C.
51	N.C.
53	N.C.
55	N.C.
57	N.C.
59	N.C.
61	N.C.
63	N.C.

Pin	Signal
2	PMCIO[2]
4	PMCIO[4]
6	PMCIO[6]
8	PMCIO[8]
10	PMCIO[10]
12	PMCIO[12]
14	PMCIO[14]
16	PMCIO[16]
18	PMCIO[18]
20	PMCIO[20]
22	PMCIO[22]
24	PMCIO[24]
26	PMCIO[26]
28	PMCIO[28]
30	PMCIO[30]
32	PMCIO[32]
34	PMCIO[34]
36	PMCIO[36]
38	PMCIO[38]
40	PMCIO[40]
42	PMCIO[42]
44	PMCIO[44]
46	PMCIO[46]
48	N.C.
50	N.C.
52	N.C.
54	N.C.
56	N.C.
58	N.C.
60	N.C.
62	N.C.
64	N.C.

5.5 PCI and Additional CompactPCI Signal Description

Mnemonic	Description
AD[0] to AD[31]	Address/Data bits. Multiplexed address and data bus.
ACK64#	Acknowledge 64-bit Transfer. Driven low by the device to indicate that the target is willing to transfer data using 64 bits.
BUSMODE#1	Bus Mode 1. Driven low by a PMC module to indicate that it supports the current bus mode.
BUSMODE#2 to BUSMODE#4	Bus Mode. Driven by the host to indicate the bus mode. Always set to PCI mode on PowerEngineC7.
C/BE0# to C/BE3#	Command/Byte Enables. During the address phase, these signals specify the type of cycle to carry out on the PCI bus. During the data phase the signals are byte enables that specify the active bytes on the bus.
CLK[0..6]	Clock. Except RST*, all 32-bit PCI bus signals are synchronous to 33 MHz clock.
DEGXB	Power supply status
DEVSEL#	Device Select. Driven low by a PCI agent to signal that it has decoded its address as the target of the current access.
FALXB	Power supply status
FRAME#	FRAME. Driven low by the current master to signal the start and duration of an access.
GA[4...0]	Geographical addressing. The geographical addressing signals are used for unique slot identification. These signals provide a unique address within the system.
GNT[0..6]#	Grant. Driven low by the arbiter to grant PCI bus ownership to a PCI agent.
IDSEL	Initialization Device Select. Device chip select during configuration cycles.
INTA# to INTD#	Interrupt lines. Level-sensitive, active-low interrupt requests.
IRDY#	Initiator Ready. Driven low by the initiator to signal its ability to complete the current data phase.
LOCK#	LOCK. Driven low to indicate an atomic operation that may require multiple transactions to complete.
M66EN	M66EN. 66 MHz enabling lines is defined as GND for 33 MHz backplanes.
N.C.	This pin is not connected.
PAR	Parity. Parity protection bit for AD0 to AD31 and C/BE0# to C/BE3#.

Page 1 of 2

Mnemonic	Description
PERR#	Parity Error. Driven low by a PCI agent to signal a parity error.
PMCIO[1] to PMCIO[46]	32-bit PCI PMC signals. Used to transmit I/Os signals from PMC connector (J14) to J2 connector.
REQ[0...3]#	Request. Driven low by a PCI agent to request ownership of the PCI bus.
REQ64#	Request 64-bit Transfer. Driven low by the current bus master, indicates that it desires to transfer data using 64 bits.
RST#	Reset. Driven low to reset the PCI bus.
SERR#	System Error. Driven low by a PCI agent to signal a system error.
STOP#	STOP. Driven low by a PCI target to signal a disconnect or target-abort.
SYSEN#	Level to 0 shows the board is system slot.
TCK	Test Clock. Used to clock state information and test data into and out of the device during operation of the TAP (JTAG) controller.
TDI	Test Data Input. Used to serially shift test data and test instructions into the device during TAP operation.
TDO	Test Data Output. Used to serially shift test data and test instructions out of the device during TAP operation.
TMS	Test Mode Select. Used to control the state of the TAP controller in the device.
TRST#	Test Reset. Provide an asynchronous initialization of the TAP controller.
TRDY#	Target Ready. Driven low by the current target to signal its ability to complete the current data phase.
V(I/O)	Power supply delivered by the board. Fixed by the backplane.
+3.3V	+3.3 Volts DC power
+5V	+5 Volts DC power
+12V	+12 Volts DC power. Not used on PowerEngineC7 board, only routed to the PMC slot.
-12V	-12 Volts DC power. Not used on PowerEngineC7 board, only routed to the PMC slot.

Page 2 of 2

5.6 Other Signal Description

Mnemonic	Description
BF_OUT	Level to 1: the board is operational.
ETH0_RX+/ETH0_RX-	Ethernet 0 Receive data.
ETH0_TX+/ETH0_TX-	Ethernet 0 Transmit data.
ETH1_RX+/ETH1_RX-	Ethernet 1 Receive data.
ETH1_TX+/ETH1_TX-	Ethernet 1 Transmit data.
GPIO[0..1]	From J2 connector to MV64460 Host Bridge MPP interface.
JTCK	JTAG clock for PMC site.
JTDI	JTAG input for PMC site.
JTDO	JTAG output for PMC site.
JTMS	JTAG validation for PMC site.
JTRST#	JTAG reset for PMC site.
PROT_BOOT	System Flash write protect signal. This signal allows write access when set up to 0V.
PROT_PROG	User Flash write protect signal. This signal allows write access when set up to 0V.
RS232_RX	EIA-232 Receive data.
RS232_TX	EIA-232 Transmit data.
RS485_RCX+/RS485_RCX-	EIA-485 Clock receive data (input signal).
RS485_RX+/RS485_RX-	EIA-485 Receive data (input signal, no termination on the signal).
RS485_TCX+/RS485_TCX-	EIA-485 Clock transmit data (output signal).
RS485_TX+/RS485_TX-	EIA-485 Transmit data (output signal).
RST_BP#	RESET signals towards tooling switch.
SMI#	CPU input interrupt.

5.7 P3 Connector Pin Assignment

The JTAG boundary scan features is used for board testing while the COP features is used mainly for hardware and software debug. The COP uses the JTAG serial lines and acts as an emulator for the processor (display of internal registers, disassembler, software breakpoints, ...).

» CPU COP Interface

P3 connector allows the connection of software debugging tools that use the CPU COP interface port to control the operation of the processor.

» Pin Assignment

Pin	Signal
1	PPC_TDO
3	PPC_TDI
5	N.C.
7	PPC_TCK
9	PPC_TMS
11	PPC_SRESET*
13	PPC_HRESET*
15	PPC_CKSTPOUT*

Pin	Signal
2	PPC_QACK
4	PPC_TRST*
6	VCC
8	PPC_CKSTPIN*
10	EN_PPC_TRST*
12	N.C.
14	N.C.
16	GND

» COP JTAG Equipment

A COP JTAG equipment, order code COP-PN3-A is available.

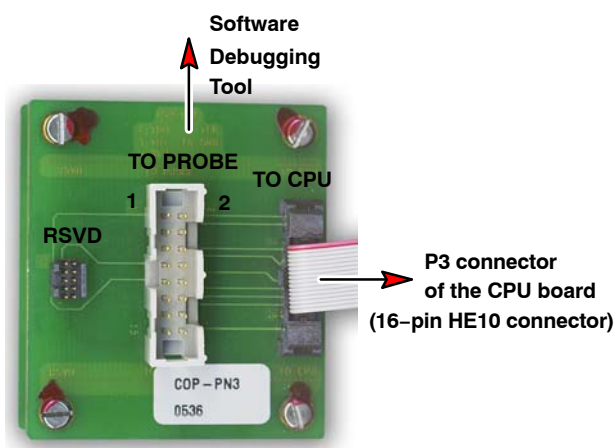

Figure 10: COP JTAG Equipment

» P3 Signal Description

Mnemonic	Description
EN_PPC_TRST*	Enable Processor (JTAG Test Reset)
GND	Logical ground
N.C.	This pin is not connected.
PPC_CKSTPOUT*	Processor checkstop output (CKSTP_OUT* signal)
PPC_CKSTPIN*	Processor checkstop input (CKSTP_IN* signal)
PPC_HRESET*	Processor hard reset input (HRESET* signal)
PPC_QACK*	Processor QACK* signal. ⁽¹⁾
PPC_SRESET*	Processor (soft reset input (SRESET* signal)
PPC_TCK	Processor (JTAG Test Clock)
PPC_TDI	Processor (JTAG Test Data In)
PPC_TDO	Processor (JTAG Test Data Out)
PPC_TMS	Processor (JTAG Test Mode Select)
PPC_TRST*	Processor(JTAG Test Reset)
VCC	Power Supply (+2.5V max.)

(1) In some JTAG emulator, QACK signal is used for software triggering. Refer to the PowerPC MAX Microprocessor Implementation Definition Book IV for more information.

5.8 P4 Connector Pin Assignment

The use of this connector is reserved for manufacturing tests. The P4 connector is not available for customer.

Chapter 6 - PMC Site

The PowerEngineC7 provides a 32-bit wide PMC site operating at 33 or 66 MHz.

Kontron products include standard PMCs such as Avionic I/O PMC (PMC-6L), HOTLINK2 PMC (PMC-HTLK). Refer to the Release Notes associated with your operating system for more information about the supported PMCs.



Electrostatic Discharge (ESD) can damage components. To avoid ESD damage, the board should be kept in its protective antistatic packaging until it is ready to be installed. During installation make sure to wear an antistatic wrist strap to discharge static electricity.

6.1 Description

The following table sums up all information concerning the PMC site. It gives information needed for software and hardware configuration.

FUNCTION	VALUE	MEANING
PCI 32 PMC Connectors	J11	Contains the signals for the 32-bit PCI bus.
	J12	Contains the signals for the 32-bit PCI bus.
	J14	Contains the User Defined I/O signals.
V(I/O) Voltage Level	Default: +3.3V	V(I/O) of PMC set to +3.3V. The user must check that its PMC type is compatible with the signaling voltage defined by the PowerEngineC7 (refer to section 6.2 page 38).
32-bit PCI Bus Mode	32 Bits	The 32-bit PCI bus is in 32-bit mode.
32-bit PCI Bus Rate	33/66 MHz	The 32-bit PCI bus runs at 33 or 66 MHz.
32-bit PCI Interrupts	INTA	Connected to the MV64460 host bridge.
	INTB	Connected to the MV64460 host bridge.
	INTC	Not connected.
	INTD	Not connected
Bus Number	0	Indicates which PCI bus is being configured.
AD[x] line of the 32-bit PCI Address/Data Bus (Device Number)	15	Decoded in the DISCOVERY (AD[31] of the PCI0 bus), used to select the PCI 32 PMC to be configured on the 32-bit PCI bus.

Table 2: PMC Site Information

6.2 Signaling Voltage Keying Pin

The PMC keying pin is a safety device used to avoid electrical damage due to a mismatch voltage on the V(I/O) base of the PCI bus better known as "PCI signaling".

One should not confused signaling voltage and power supply voltages on the PCI or the component technology.

On the PowerEngineC7, the signaling level is set by default to +3.3V (i.e. V(I/O)=+3.3V). The V(I/O) pins of the PMC are connected to +3.3V and the keying pin is positioned as shown on Figure 11.

On the PowerEngineC7 PMC slot, only the two following PMC types must be intalled:

» +3.3V PMC:

It is designed to work only in a +3.3V signaling level and will only have a keying hole matching the +3.3V keying pin of the motherboard.

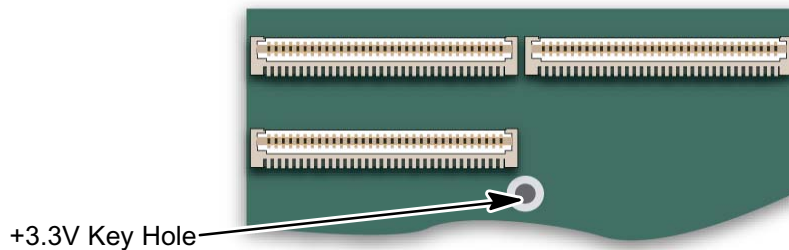

Figure 11: +3.3V PMC

» Universal PMC:

It supports both voltages (+5V and +3.3V). This PMC is capable of detecting the signaling level in use and adapting itself to that environment. It has two keying holes (+5V and +3.3.V) and can, therefore, be plugged into either signaling level.

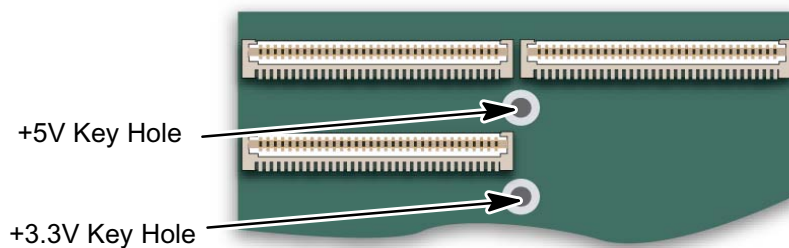

Figure 12: Universal PMC

Before installing your PMC on the PowerEngineC7, check that its keying hole matches the voltage keying pin of the PowerEngineC7.



Do not remove the keying pins on the PowerEngineC7. They agree with the V(I/O) supplied by the board. Do not insert PMCs which do not provide the associated keying hole. If both voltages can be supported by your PMC, then both holes are provided.



+5V only PMC support: The PowerEngineC7 may be configured at the manufacturing to support a +5V only PMC. Please, contact Kontron on the availability.

6.3 PMC Installation

This site can operate at 33 or 66 MHz with data width of 32 bits (refer to Table 2 for more information about the PMC site configuration).

PMC modules are delivered with a full kit of parts for mounting them, and the user guide for the module normally contains instructions on how to fit the module.

To install the PMC module, refer to Figure 13 "PMC Slot" on page 39 and follow the steps below:



To avoid ESD damage, wear an antistatic wrist strap to discharge static electricity while performing any part of the installation that involves touching the PowerEngineC7 board or the PMC. If you can't wear an antistatic wrist strap, touch one hand to the bare metal surface to provide grounding.

1. Place carefully the PowerEngineC7 with the backplane connectors facing you on a static dissipative surface connected to a common ground by a low-resistance connection. Do not slide the board over any surface.
2. Install the PMC, component-side down, aligning the PCI connectors with their mating connectors on the PowerEngineC7. Press them together so that the friction from the pins holds them together. Insert the standoff plug mounted on the PowerEngineC7 into the keyhole.
3. Screw the PMC in place using the 4 mounting points, on the bottom side of the PMC. You need a Phillips screwdriver for this stage.
4. The PMC attachment is now complete.
5. Insert the PowerEngineC7 into the chassis making sure it is plugged into the backplane.

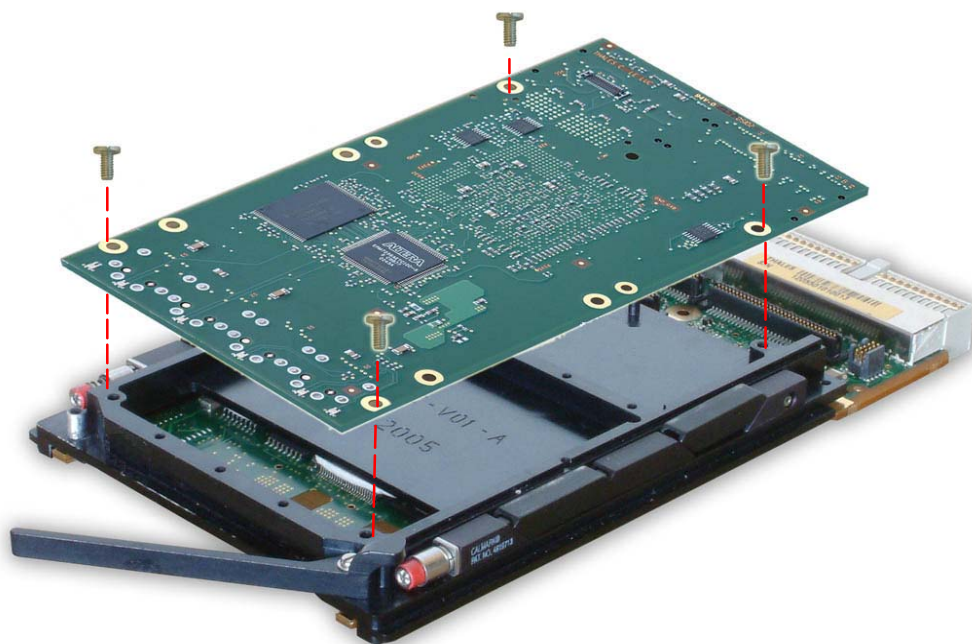
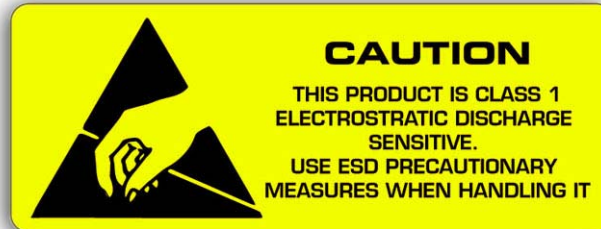

Figure 13: PMC Slot

Chapter 7 - System Installation

This chapter describes the installation of the PowerEngineC7 board in a system.



1. The PowerEngineC7 must be installed in a CompactPCI chassis.
2. The PowerEngineC7 is not a hot swappable board but it may be inserted in a hot swap chassis with power applied.
3. Set the V(I/O) on the backplane to either +3.3V or +5V, depending upon your PCI system signaling requirements.
Generally, the V(I/O) on the backplane is fixed by manufacturers at +5V.
4. Slide the PowerEngineC7 into the appropriate slot. Grasping the top and bottom injector handles, be sure the module is well seating in the P1 through P2 connectors on the backplane. Do not damage or bend connector pins.
5. Secure the PowerEngineC7 in the chassis with the screws provided, making good contact with the transverse mounting rails to minimize RF emissions.
6. Replace the chassis or system cover(s), making sure no cables are pinched. Cable the peripherals to the panel connectors, reconnect the system to the AC or DC power source, and turn the equipment power on.

7.1 Power Up Specifications

Wait for a minimal delay of 1 second between a power down and a power up of the system, to make sure that the power supply of the board have reached 0V.

7.2 +5V Power Specifications

The PowerEngineC7 draws the internal and V(I/O) PMC +5V power from the +5V providing to the backplane via the J1 connector.

The rising of the +5V voltage must be monotonic and should not last for more than 25 ms.

7.3 +3.3V Power Specifications

The PowerEngineC7 draws the internal and V(I/O) PMC +3.3V power from the +3.3V providing to the backplane via the J1 connector.

The rising of the +3.3V voltage must be monotonic and should not last for more than 25 ms.

7.4 V(I/O) Power Recommendations

The PowerEngineC7 draws the CompactPCI V(I/O) (+3.3V or +5V) power from the V(I/O) providing to the backplane via the J1 connector.

Generally, the V(I/O) on the backplane is fixed by manufacturers at +5V.

7.5 V(I/O) PMC Power Specifications

V(I/O) voltage is delivered by the PowerEngineC7.

By default, the bus signaling voltage implemented on the PowerEngineC7 is +3.3V on the PCI-32 bus and PMC site.

Signaling bus levels (+5V or +3.3V), used by the PCI busses, are connected to the V(I/O) pins of the PMC connectors.

Power consumption and heat dissipation of the PMC (+5V and +3.3V) should not exceed 7.5W as described in the IEEE P1386 standard.

V(I/O) current consumption must not exceed 300 mA per PMC.

7.6 12V Power Specifications

The PowerEngineC7 draws the $\pm 12V$ power from the backplane via the J1 connector to PMC site only.

7.7 System Configuration Suggestions

Use the PowerEngineC7 in a rack on its own at first, and only plug it in with other cards later (if other cards are to be used). This enables you to try basic operation before tackling any system configuration issues.

Chapter 8 - Operating Instructions

This chapter describes the power-up procedure, the RESET switch and LEDs, memory maps and software initialization of the PowerEngineC7.

8.1 Power-up

1. Check that the connections have been made correctly: refer to Chapter 5 "Connectors".
2. Verify the PMC has been correctly plugged into the PowerEngineC7: refer to Chapter 6 "PMC Site".
3. Verify the backplane configuration is complete and the PowerEngineC7 firmly secured in the rack; take care of the system configuration suggestions: refer to Chapter 7 "System Installation".
4. Power-up the system.



Wait for a minimal delay of 1 second between a power down and a power up of the system, to make sure that the power supply of the board have reached 0V.

8.2 Reset Switch

There is no reset toggle switch on the board.

A hard reset can be generated from a reset toggle switch connected to the RST_BP signal (C17) on the J2 CPCI connector. This signal is active at low level (0).

8.3 LEDs

Nine LEDs are located on the bottom side of the board.

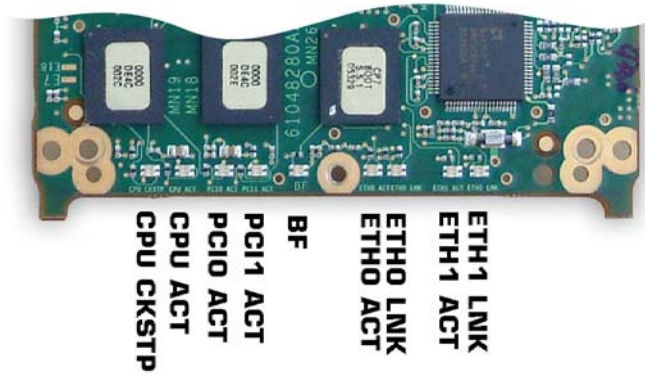

Figure 14: LEDs Setting

LED	Description
ETH1 LNK ● Green	When Green, this LED indicates active connection to network.
ETH1 ACT ● Green	When Green, this LED indicates active connection (link) at 10/100 Mbps of the Ethernet 1 controller.
ETH0 LNK ● Green	When Green, this LED indicates active connection to network.
ETH0 ACT ● Green	When Green, this LED indicates active connection (link) at 10/100 Mbps of the Ethernet 0 controller.
BF ● Green	When Green, this LED indicates that the board is operational. When switched off, this LED indicated that the power supply of the board is cut except during the VxWorks boot where a few seconds are required before the LED switches on.
PCI1 ACT ● Green	When Green, this LED indicates active transfer on PCI1 bus (backplane)
PCI0 ACT ● Green	When Green, this LED indicates active transfer on PCI0 bus (PMC)
CPU ACT ● Green	When Green, this LED indicates active transfer on CPU bus
CPU CKSTP ● Red	When Red, this LED indicates a checkstop condition for CPU. It is connected to CKSTP_OUT* signal of CPU

Table 3: LEDs Description

8.4 Memory Map

8.4.1 System Slot Memory Map Setup by VxWorks

Memory Map setup by VxWorks for the system slot board (as seen by CPU):

- DDR SDRAM memory space: the 256 MB implemented are selected by CS[0].
- User Flash memory space: the 128 MB implemented are selected by DevCS[0].
- System Flash memory space: the 64 MB implemented are selected by BootCSn.
- The specific PLD control register is selected by DevCS[1].
- PCI0 is the 32-bit PCI bus and PCI1 is the 32-bit cPCI bus.
- PCI1 memory area is divides in windows of 64 MB, each window is mapped on the first 64 MB of the DDR SDRAM of a peripheral slot board.



- The memory spaces selected by CS[1:3] are not used.
 - The memory space selected by DevCS[3] is not used.



In current VxWorks implementation, up to seven peripheral slot boards can be managed by the system slot board.

Processor Address Range	Size	Function
0x0000.0000 -> 0x0FFF.FFFF	256 MB	CS[0] DDR SDRAM
0x8000.0000 -> 0x83FF.FFFF	64 MB	PCI1 I/O Space
0x8400.0000 -> 0x87FF.FFFF	64 MB	PCI1 Memory: Mem0
0x8800.0000 -> 0x8FFF.FFFF	128 MB	PCI1 Memory: Mem1
0x9000.0000 -> 0x97FF.FFFF	128 MB	PCI1 Memory: Mem2
0x9800.0000 -> 0x9FFF.FFFF	128 MB	PCI1 Memory: Mem3
0xC000.0000 -> 0xCFFF.FFFF	128 MB	DevCS[0] (User Flash)
0xE000.0000 -> 0xE1FF.FFFF	32 MB	PCI0 I/O Space
0xE200.0000 -> 0xE3FF.FFFF	32 MB	PCI0 Memory: Mem0
0xE400.0000 -> 0xE7FF.FFFF	64 MB	PCI0 Memory: Mem1
0xE800.0000 -> 0xEBFF.FFFF	64 MB	PCI0 Memory: Mem2
0xEC00.0000 -> 0xEFFF.FFFF	64 MB	PCI0 Memory: Mem3
0xF020.0000 -> 0xF02F.FFFF	1 MB	DevCS [1] (PLD Control Registers)
0xF030.0000 -> 0xF03F.FFFF	1 MB	DevCS [2] (nvSRAM)
0xF100.0000 -> 0xF110.FFFF	64 KB	Internal Discovery Register
0xF200.0000 -> 0xF203.FFFF	256 KB	Internal SRAM
0xFC00.0000 -> 0xFFFF.FFFF	64 MB	BootCSn (System Flash)

Table 4: PowerEngineC7 System Slot Memory Map Setup by VxWorks

8.4.2 Peripheral Slot Memory Map Setup by VxWorks

Memory Map setup by VxWorks for the peripheral slot board (as seen by CPU):

- DDR SDRAM memory space: the 256 MB implemented are selected by CS[0].
- User Flash memory space: the 128 MB implemented are selected by DevCS[0].
- System Flash memory space: the 64 MB implemented are selected by BootCSn.
- The specific PLD control register is selected by DevCS[1].
- PCI0 is the 32-bit PCI bus and PCI1 is the 32-bit cPCI bus.
- PCI1 memory area is divided in windows of 64 MB, each window is mapped on the first 64 MB of the DDR SDRAM of the system slot board.



- The memory spaces selected by CS[1:3] are not used.
- The memory space selected by DevCS[3] is not used.



Two kinds of peripheral slot boards are managed:

- the peripheral slot boards cPCI master, able to manage read/write accesses through the cPCI bus to access the system slot board.
- the peripheral slot boards cPCI slave only, not able to manage read/write accesses through the cPCI bus.

Processor Address Range	Size	Function
0x0000.0000 → 0x0FFF.FFFF	256 MB	CS[0] DDR SDRAM
0xA000.0000 → 0xA1FF.FFFF	64 MB	PCI1 I/O Space
0xC000.0000 → 0xCFFF.FFFF	128 MB	DevCS[0] (User Flash)
0xD000.0000 → 0xD3FF.FFFF	64 MB	PCI1 Memory: Mem0
0xD400.0000 → 0xD7FF.FFFF	64 MB	PCI1 Memory: Mem1
0xD800.0000 → 0xDBFF.FFFF	64 MB	PCI1 Memory: Mem2
0xDC00.0000 → 0xDFFF.FFFF	64 MB	PCI1 Memory: Mem3
0xE000.0000 → 0xE1FF.FFFF	32 MB	PCI0 I/O Space
0xE200.0000 → 0xE3FF.FFFF	32 MB	PCI0 Memory: Mem0
0xE400.0000 → 0xE7FF.FFFF	64 MB	PCI0 Memory: Mem1
0xE800.0000 → 0xEBFF.FFFF	64 MB	PCI0 Memory: Mem2
0xEC00.0000 → 0xEFFF.FFFF	64 MB	PCI0 Memory: Mem3
0xF020.0000 → 0xF02F.FFFF	1 MB	DevCS[1] (PLD Control Registers)
0xF030.0000 → 0xF03F.FFFF	1 MB	DevCS [2] (nvSRAM)
0xF100.0000 → 0xF1100.FFFF	64 KB	Internal Discovery Register
0xF200.0000 → 0XF203.FFFF	256 KB	Internal SRAM
0xFC00.0000 → 0xFFFF.FFFF	64 MB	BootCSn (System Flash)

Table 5: PowerEngineC7 Peripheral Slot Memory Map Setup by VxWorks

8.5 Hardware Reset

The following figure shows a simplified block diagram of the hardware reset sources and their propagation:

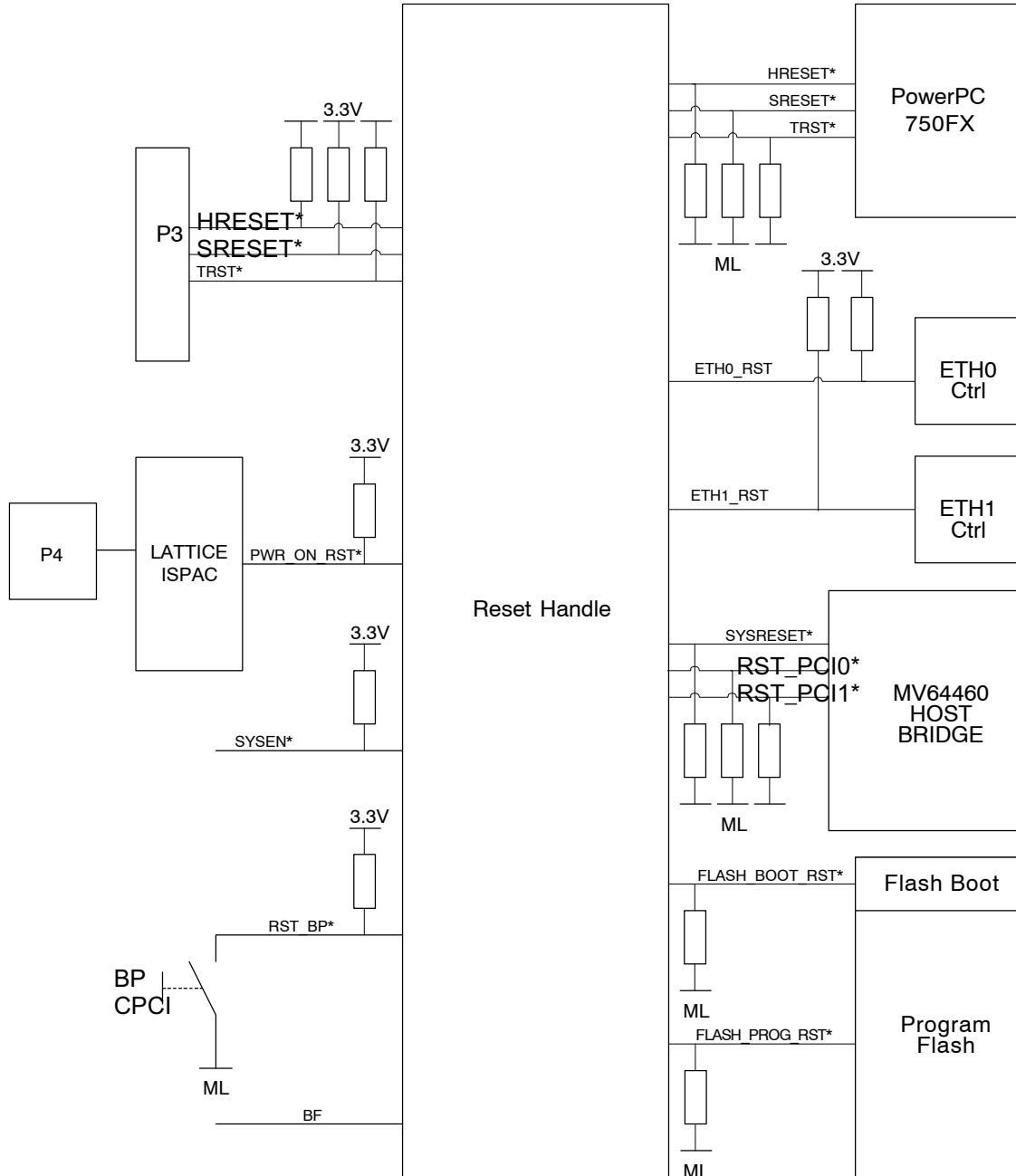

Figure 15: PowerEngineC7 Hardware Reset Block Diagram

» Hardware Reset Sources

Sources of hardware reset acting on the system and propagated on the board are:

- HRESET signal from the P3 (COP) connector. Active at low level (0).
- SRESET signal from the P3 (COP) connector. Active at low level (0).
- TRST signal from the P3 (COP) connector. Active at low level (0).
- Power-up power supply breakdown. Active at low level (0).
- RST_BP signal signal (C17) from the J2 CPCI connector. Active at low level (0).
- Watchdog timer. Refer to chapter 4.2.1 "Host Bridge", section "Watchdog Timer".
- PCI1 reset (RST_PCI1).

These hardware reset sources generate the:

- Program FLASH reset (FLASH_PROG_RST),
- PCI0 reset (RST_PCI0),
- PCI1 reset (RST_PCI1),
- Host bridge reset (SYSRESET),
- Enable reset processor (TRST),
- Hard reset processor (HRESET),
- Soft reset processor (SRESET).

The following table shows the reset generated by the hard reset sources:

	Hard Reset Sources							
	P3 Connector (COP)			PWR_ON_RST*	RST_BP*	BF (software programmable bit)	WATCHDOG Timer	RST_PCI1* (if not system controller)
	HRESET*	SRESET*	TRST*					
Generated Reset								
FLASH_PROG_RST*								
RST_PCI0*								
RST_PCI1*				In system slot	In system slot			
SYSRESET*								
CPU TRST*								
CPU HRESET*								
CPU SRESET*								
BF (LED and backplane I/O)								

Table 6: Reset Generated by the Hard Reset Sources

8.6 Software Reset

The Software Reset of the processor should be considered as an ABORT exception and must not be confused with a Hardware Reset generated by software means - an access to some register for instance. In the former case only the processor input SRESET is activated whereas in the latter case, the processor input HRESET is activated along with most of the hardware Reset signals of the board.

The source of software reset on the PowerEngineC7 board is the SRESET signal from the P3 (COP) connector.

8.7 PCI Configuration

The access to the PCI configuration spaces is as follows:

» PCI0 Accesses:

AD[x] line of the 32-bit PCI Address/Data Bus connected to the IDSEL pin	CONFIG_ADDR Value	Read Value	REQ[1]/GNT[1]
0	0x0000.0000	0x11AB.6460	
15	0x0000.0F00	DeviceID/VendorID Agent 1	1

Table 7: PCI0 Accesses

» PCI1 Accesses:

AD[x] line of the 32-bit PCI Address/Data Bus connected to the IDSEL pin	CONFIG_ADDR Value	Read Value	REQ[1]/GNT[1]
0	0x0000.0000	0x11AB.6460	Host Bridge
15	0x0000.0F00	DeviceID/VendorID Slot 2	0
14	0x0000.0E00	DeviceID/VendorID Slot 3	1
13	0x0000.0D00	DeviceID/VendorID Slot 4	2
12	0x0000.0C00	DeviceID/VendorID Slot 5	3
11	0x0000.0B00	DeviceID/VendorID Slot 6	Slave agent
10	0x0000.0A00	DeviceID/VendorID Slot 7	Slave agent
9	0x0000.0900	DeviceID/VendorID Slot 8	Slave agent

Table 8: PCI1 Accesses

Chapter 9 - Inserting and Removing the Board

9.1 Inserting the Board

1. Insert the board into the backplane of the rack.
2. Screw both hexagonal socket drive 3/32 across flats with a 3/32 Allen wrench. The recommended torque is 6 in. lbs.

 Conduct the installation using a torque spanner with the recommended torque of 6 in. lbs.

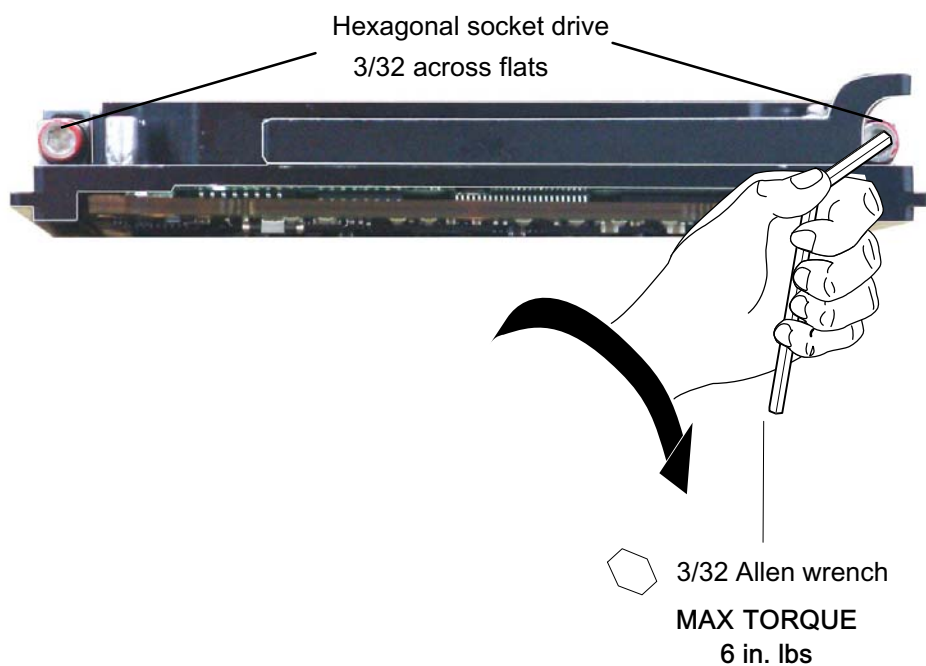

Figure 16: Inserting the Board

9.2 Removing the Board

1. Unscrew both hexagonal socket drive 3/32 across flats with a 3/32 Allen wrench.
2. Remove the board from the backplane of the rack.

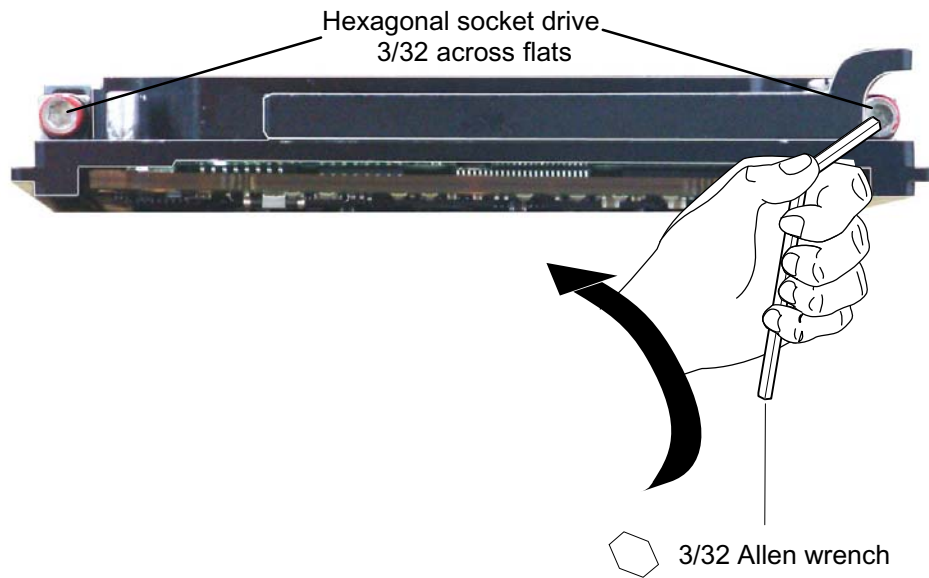

Figure 17: Removing the Board

Chapter 10 - I/O Transition Module

Kontron Order Code: PB-CP7-000

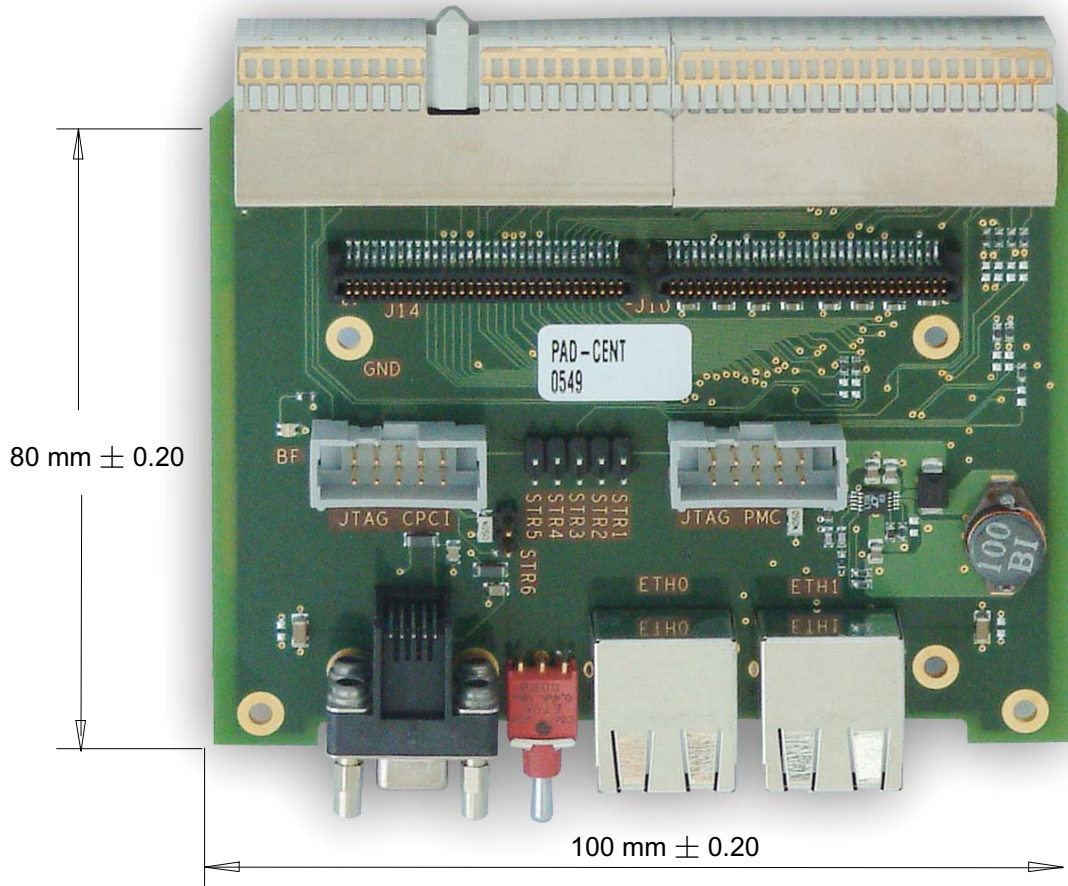

Figure 18: PowerEngineC7 I/O Transition Module

10.1 Installing the PowerEngineC7 I/O Transition Module

The PowerEngineC7 I/O transition module is designed to be used with a CompactPCI extensions backplane.

The I/O transition module plugs into the RJ2 connector, on the back side of the CompactPCI backplane, in the same slot as the PowerEngineC7 board. To install the board:

1. Make sure the system and peripheral equipment power are off.
2. Install the cables into the appropriate connectors on the transition module.
3. Line-up the RJ2 connector on the transition module with the J2 connector on the backplane.
4. Press the outer edge of the transition module until the board is firmly seated in the connector.
5. Connect any additional cables.
6. Turn on system power.

10.2 Reset Switch

The PowerEngineC7 reset is available on the reset switch of the front panel of the PowerEngineC7 I/O transition module. This hard reset is connected to the RST_BP# signal (C17) on the RJ2 CPCI connector. Refer to Figure 21 page 54 for more information about the setting of the reset switch on the front panel of the I/O transition module.

10.3 Links and GPIOs

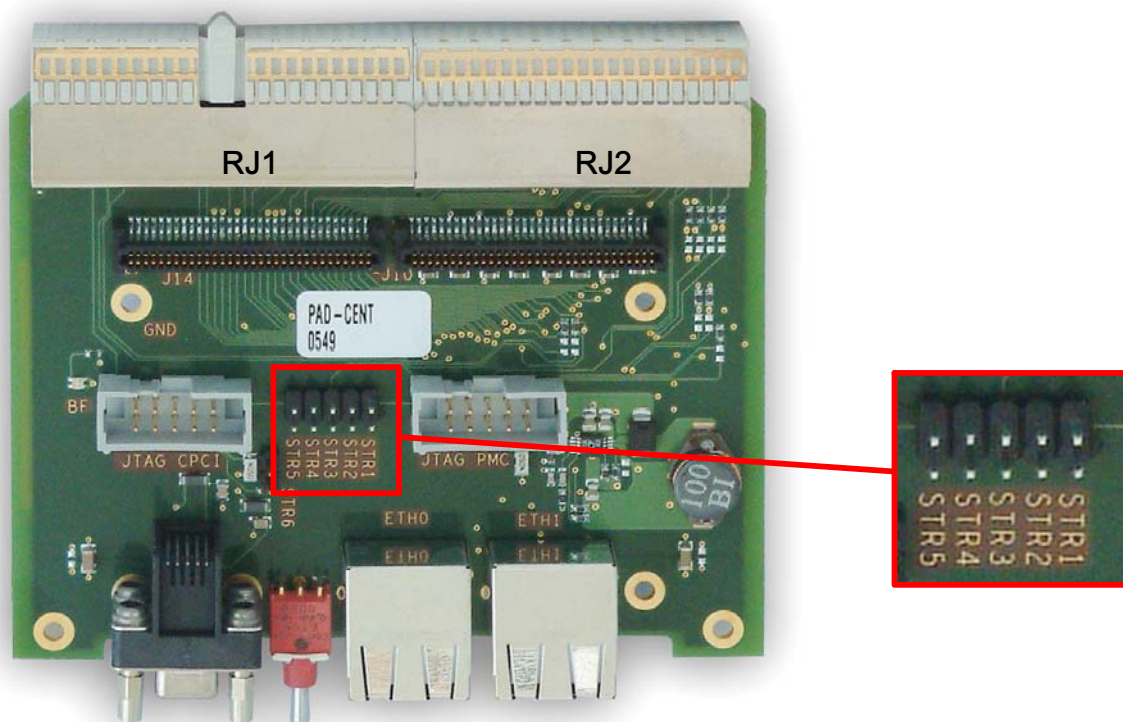

Figure 19: PowerEngineC7 I/O Transition Module

Link	Default Setting	Action	Signal Name	RJ2 Connector Pinout
STR1	OUT	OUT: User Flash EPROM is write protected IN: User Flash EPROM is write enabled PROT_PROG signal allows write access when set up to 0.	PROT_PROG	B-15
STR2	OUT	OUT: System Flash EPROM is write protected IN: System Flash EPROM is write enabled PROT_BOOT signal allows write access when set up to 0	PROT_BOOT	B-17
STR3	OUT	OUT: Start up activated in Standard Mode IN: Start up activated in Rescue Mode Refer to section 4.2.3 “Memory” - System Flash EPROM page 21.	SMI	B-4
STR4	OUT	Reserved		
STR5	OUT	Reserved		

Table 9: Default Link Settings

10.4 Connectors

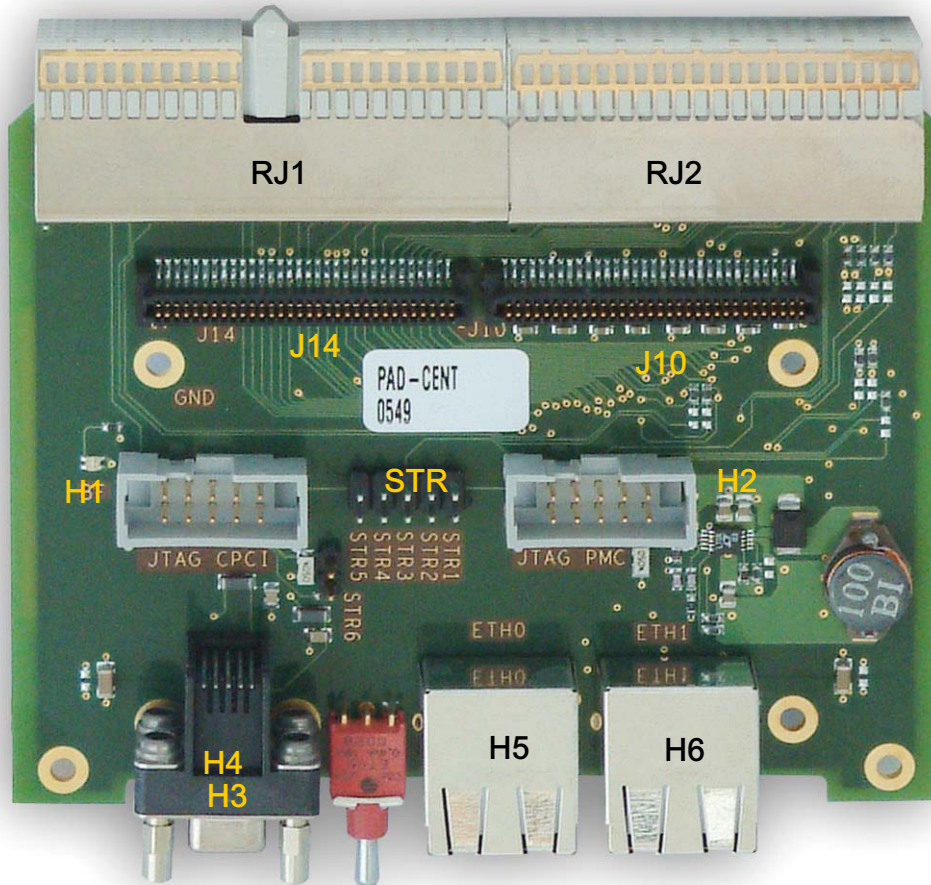

Figure 20: PowerEngineC7 I/O Transition Module Connectors

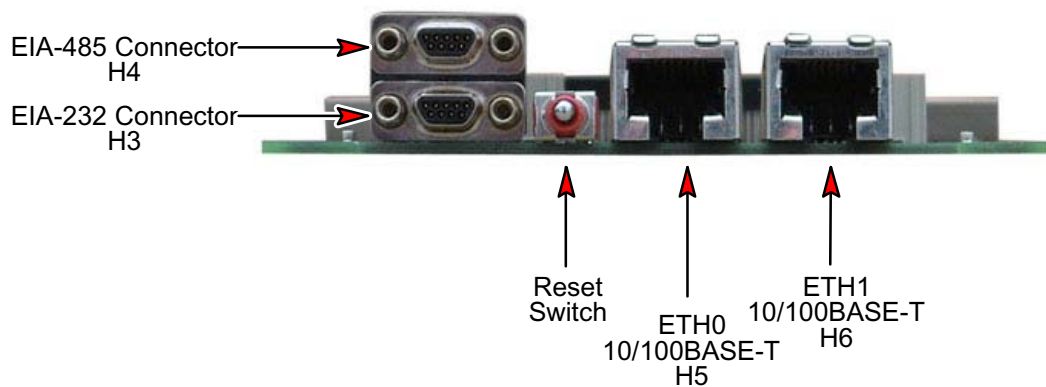

Figure 21: PowerEngineC7 I/O Transition Module Front Panel

10.4.1 RJ1 Connector Pin Assignment

Pin Number	RJ1 Connector					
	Row A Signal	Row B Signal	Row C Signal	Row D Signal	Row E Signal	Row F Signal
25	N.C.	N.C.	N.C.	N.C.	N.C.	GND
24	N.C.	N.C.	N.C.	N.C.	N.C.	GND
23	N.C.	N.C.	N.C.	N.C.	N.C.	GND
22	N.C.	GND	N.C.	N.C.	N.C.	GND
21	N.C.	N.C.	N.C.	N.C.	N.C.	GND
20	N.C.	GND	N.C.	N.C.	N.C.	GND
19	N.C.	N.C.	N.C.	GND	N.C.	GND
18	N.C.	GND	N.C.	N.C.	N.C.	GND
17	N.C.	N.C.	N.C.	GND	3V3	GND
16	N.C.	GND	N.C.	N.C.	N.C.	GND
15	N.C.	N.C.	N.C.	N.C.	N.C.	GND
12-14	KEY AREA					
11	N.C.	N.C.	N.C.	GND	N.C.	GND
10	N.C.	GND	N.C.	N.C.	N.C.	GND
9	N.C.	N.C.	N.C.	GND	N.C.	GND
8	N.C.	GND	N.C.	N.C.	N.C.	GND
7	N.C.	N.C.	N.C.	GND	N.C.	GND
6	N.C.	GND	N.C.	N.C.	N.C.	GND
5	N.C.	N.C.	N.C.	GND	N.C.	GND
4	N.C.	N.C.	N.C.	N.C.	N.C.	GND
3	N.C.	N.C.	N.C.	N.C.	N.C.	GND
2	TCK	N.C.	TMS	TDO	TDI	GND
1	N.C.	N.C.	TRST#	N.C.	N.C.	GND

PCI or additional CompactPCI signals active when low.

For more information about PCI and additional CompactPCI signals, refer to section 5.5 page 31. The other signals are described in section 5.6 page 33.

10.4.2 RJ2 Connector Pin Assignment

Pin Number	RJ2 Connector					
	Row A Signal	Row B Signal	Row C Signal	Row D Signal	Row E Signal	Row F Signal
22	N.C.	N.C.	N.C.	N.C.	N.C.	GND
21	N.C.	GND	ETH0_TX-	RS232_TX	JTCK	GND
20	N.C.	GND	ETH0_TX+	RS232_RX	JTMS	GND
19	GND	GND	ETH0_RX+	RS485_RCX+	JTDO	GND
18	ETH1_RX+	GPIO[1]	ETH0_RX-	RS485_RCX-	JTRSTX#	GND
17	ETH1_RX-	PROT_BOOT	RST_BP#	N.C.	+3V3	GND
16	ETH1_TX-	GPIO[0]	N.C.	GND	BF_OUT	GND
15	ETH1_TX+	PROT_PROG	N.C.	N.C.	N.C.	GND
14	JTDI	RS485_TCX-	RS485_TCX+	RS485_TX-	RS485_TX+	GND
13	PMCIO[5]	PMCIO[4]	PMCIO[3]	PMCIO[2]	PMCIO[1]	GND
12	PMCIO[10]	PMCIO[9]	PMCIO[8]	PMCIO[7]	PMCIO[6]	GND
11	PMCIO[15]	PMCIO[14]	PMCIO[13]	PMCIO[12]	PMCIO[11]	GND
10	PMCIO[20]	PMCIO[19]	PMCIO[18]	PMCIO[17]	PMCIO[16]	GND
9	PMCIO[25]	PMCIO[24]	PMCIO[23]	PMCIO[22]	PMCIO[21]	GND
8	PMCIO[30]	PMCIO[29]	PMCIO[28]	PMCIO[27]	PMCIO[26]	GND
7	PMCIO[35]	PMCIO[34]	PMCIO[33]	PMCIO[32]	PMCIO[31]	GND
6	PMCIO[40]	PMCIO[39]	PMCIO[38]	PMCIO[37]	PMCIO[36]	GND
5	PMCIO[45]	PMCIO[44]	PMCIO[43]	PMCIO[42]	PMCIO[41]	GND
4	N.C.	SMI#	RS485_RX-	RS485_RX+	PMCIO[46]	GND
3	N.C.	GND	N.C.	N.C.	N.C.	GND
2	N.C.	N.C.	N.C.	N.C.	N.C.	GND
1	N.C.	GND	N.C.	N.C.	N.C.	GND

PCI and additional CompactPCI signals active when low.

For more information about PCI and additional CompactPCI signals, refer to section 5.5 page 31. The other signals are described in section 5.6 page 33.

10.4.3 H1 (JTAG_CPCI) Connector Pin Assignment

H1 Pin	Signal	H1 Pin	Signal
1	TCK	2	GND
3	TDO	4	3v3_PROTECT
5	TMS	6	N.C.
7	N.C.	8	TRST#
9	TDI	10	GND

For chain1 JTAG/Boundary Scan controller. Refer to section 4.2.8 page 23.

For more information about PCI and additional CompactPCI signals, refer to section 5.5 page 31. The other signals are described in section 5.6 page 33.

10.4.4 H2 (JTAG_PMC) Connector Pin Assignment

H2 Pin	Signal	H2 Pin	Signal
1	JTCK	2	GND
3	JTDO	4	3v3_PROTECT
5	JTMS	6	N.C.
7	N.C.	8	JTRST#
9	JTDI	10	GND

For chain2 JTAG/Boundary Scan controller. Refer to section 4.2.8 page 23.

For more information about PCI and additional CompactPCI signals, refer to section 5.5 page 31. The other signals are described in section 5.6 page 33.

10.4.5 H3 (EIA-232) Connector Pin Assignment

Pin	Signal	Pin	Signal
1	N.C.	6	N.C.
2	RX	7	N.C.
3	TX	8	N.C.
4	N.C.	9	N.C.
5	Serial Ground	Shell	Chassis Ground



» Signal Description

Mnemonic	Description
N.C.	Not Connected
RX	Receive Data
TX	Transmit Data
Serial Ground	Quiet ground internally connected to 0V

10.4.6 H4 (EIA-485) Connector Pin Assignment

Pin	Signal	Pin	Signal
1	TX+	6	RX+
2	TX-	7	RX-
3	TCX+	8	RCX+
4	TCX-	9	RCX-
5	Serial Ground	Shell	Chassis Ground



» Signal Description

Mnemonic	Description
RCX+/-	Clock Receive Data
RX+/-	Receive Data
TCX+/-	Clock Transmit Data
TX+/-	Channel 0 Transmit Data
Serial Ground	Quiet ground internally connected to 0V

10.4.7 H5 (10/100BASE-T) Connector Pin Assignment (ETH0) H6 (10/100BASE-T) Connector Pin Assignment (ETH1)

Pin	Signal
1	Transmit +
2	Transmit -
3	Receive +
4	N.C.
5	N.C.
6	Receive -
7	N.C.
8	N.C.
CASE	M GND

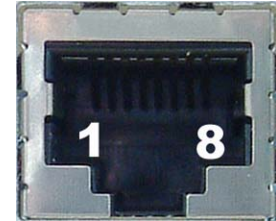

» Signal Description

Mnemonic	Description
N.C.	Not Connected
Receive+/-	Ethernet 10/100BASE-T receive data
Transmit+/-	Ethernet 10/100BASE-T transmit data
M GND	Case Ground Decoupled by 1 nF 1000V capacitor to Logic Ground



The CASE pin should be connected to the chassis ground.

10.4.8 PMC Connectors Pin Assignment

» J10 Connector Pin Assignment

Pin	Signal	Pin	Signal
1	N.C.	2	N.C.
3	N.C.	4	N.C.
5	+5V	6	N.C.
7	N.C.	8	N.C.
9	N.C.	10	+3V3
11	N.C.	12	N.C.
13	GND	14	N.C.
15	N.C.	16	N.C.
17	N.C.	18	GND
19	N.C.	20	N.C.
21	+5V	22	N.C.
23	N.C.	24	N.C.
25	N.C.	26	+3V3
27	N.C.	28	N.C.
29	GND	30	N.C.
31	N.C.	32	N.C.
33	N.C.	34	GND
35	N.C.	36	N.C.
37	+5V	38	N.C.
39	N.C.	40	N.C.
41	N.C.	42	+3V3
43	N.C.	44	N.C.
45	GND	46	N.C.
47	N.C.	48	N.C.
49	N.C.	50	GND
51	N.C.	52	N.C.
53	+5V	54	N.C.
55	N.C.	56	N.C.
57	N.C.	58	+3V3
59	N.C.	60	N.C.
61	N.C.	62	N.C.
63	N.C.	64	N.C.

The signals are described in section 5.6 page 33.

The maximal delivered current by the I/O transition module on the J10 PMC connector:

- 600 Ma on the 5V voltage
- 1 A on the 3.3V voltage

» J14 Connector Pin Assignment

Pin	Signal	Pin	Signal
1	PMCIO[1]	2	PMCIO[2]
3	PMCIO[3]	4	PMCIO[4]
5	PMCIO[5]	6	PMCIO[6]
7	PMCIO[7]	8	PMCIO[8]
9	PMCIO[9]	10	PMCIO[10]
11	PMCIO[11]	12	PMCIO[12]
13	PMCIO[13]	14	PMCIO[14]
15	PMCIO[15]	16	PMCIO[16]
17	PMCIO[17]	18	PMCIO[18]
19	PMCIO[19]	20	PMCIO[20]
21	PMCIO[21]	22	PMCIO[22]
23	PMCIO[23]	24	PMCIO[24]
25	PMCIO[25]	26	PMCIO[26]
27	PMCIO[27]	28	PMCIO[28]
29	PMCIO[29]	30	PMCIO[30]
31	PMCIO[31]	32	PMCIO[32]
33	PMCIO[33]	34	PMCIO[34]
35	PMCIO[35]	36	PMCIO[36]
37	PMCIO[37]	38	PMCIO[38]
39	PMCIO[39]	40	PMCIO[40]
41	PMCIO[41]	42	PMCIO[42]
43	PMCIO[43]	44	PMCIO[44]
45	PMCIO[45]	46	PMCIO[46]
47	N.C.	48	N.C.
49	N.C.	50	N.C.
51	N.C.	52	N.C.
53	N.C.	54	N.C.
55	N.C.	56	N.C.
57	N.C.	58	N.C.
59	N.C.	60	N.C.
61	N.C.	62	N.C.
63	N.C.	64	N.C.

The signals are described in section 5.6 page 33.

Appendix A - Specifications

This appendix gives a specification of the PowerEngineC7. It also covers items such as power requirements, environment specifications, etc.

A.1 Local Resources

- Processor One PowerPC 750FX operating at 700 MHz with a 512 KB internal L2 cache.
- SDRAM 256 MB of onboard DDR SDRAM with ECC operating at 200 MHz - DDR.
- System Flash EPROM 64 MB of System Flash EPROM.
- User Flash EPROM 128 MB of contiguous directly-accessible, 32-bit wide Flash memory for OS and application code.
- Non volatile SRAM 128 KB of non volatile SRAM with RT clock.
- PCI0 PCI bus 32-bit, 33/66 MHz
- PCI1 PCI bus 32-bit, 33 MHz
- PMC Slot 32-bit IEEE P1386.1 compliant slot. From 33 to 66 MHz PCI, 32 bits bus width. V(I/O) set to +3.3V.
- Ethernet Two IEEE 802.3 10/100BASE-T via the J2 connector.
- Serial I/O One simplified serial port EIA-232 via the J2 connector.
One simplified serial port EIA-485/EIA-422 via the J2 connector.
- Status LEDs 9 LEDs
- Operating Systems Tornado 2.2.1/VxWorks 5.5.1, Workbench 2.4/VxWorks 6.2 and further versions

A.2 Power Requirements

» Power Consumption

	PowerEngineC7
+5 V +5 %, -2.5 %	≈ 0.2 W
+3.3V +5 %, -2.5 %	≈ 10.5 W
+12 V +5 %, -2.5 %	Not Applicable
-12 V +5 %, -2.5 %	Not Applicable



Only use the PowerEngineC7 in backplanes that supply power on the J1 connector. Failure to observe this warning may result in damage to the board.

A.3 EMC Regulatory Compliance and Safety

The PowerEngineC7 is designed for use in systems meeting EN55082 or EN 55022 Class A regulations for EMC emissions and susceptibility.

A.4 Flammability Rating

All PCBs are manufactured by UL approved manufacturers and have a flammability rating of 94V-0.

A.5 Environmental Specifications

A.5.1 Operating Environment

The PowerEngineC7 will operate under the following conditions:

- **Temperature range** VITA47-Class CC4
-40 to +85° C plug-in unit temperature, on the surface of the edge that contacts the rack/enclosure
- **Relative humidity** Up to 95% without condensation.
- **Altitude** from -1000 to 50000 feet (-500 to 15000 meters) approximatively.
- **Sinusoidal vibration** 2.5 mm peak from 5 Hz to 22 Hz
5g Peak from 22 Hz to 2000 Hz (3 axis, 1 hour per axis, 1 octave per mm)
- **Random vibration** VITA47-Class V3
0.1 g²/Hz from 10 Hz to 1000 Hz
-6dB/octave from 1000 Hz to 2000 Hz (3 axis, 1 hour per axis)
- **Gunfire vibration** 40 g for 6 ms half sine (peak), 1000 bumps per directions, 3 bumps per second.
- **Acceleration** 2 g during 5 mn, 6 directions
- **Mechanical shock** 40 g for 20 ms half sine (peak), 6 directions, 3 shocks/direction when mounted in suitable enclosure.

A.5.2 Storage Environment

The PowerEngineC7 may be stored or transported without damage within the following limits:

- **Temperature range** VITA47-Class CC4
-45 to +100° C.
- **Relative humidity** Up to 95% without condensation.
- **Altitude** from -1000 to 50000 ft (-500 to 15000 meters) approximatively.
- **Random vibration** VITA47-Class V3
0.1 g²/Hz from 10 Hz to 1000 Hz
-6dB/octave from 1000 Hz to 2000 Hz (3 axis, 1 hour per axis)
- **Gunfire vibration** 40 g for 6 ms half sine (peak), 1000 bumps per directions, 3 bumps per second.
- **Mechanical shock** 40 g for 20 ms (half sine), 6 directions, 3 shocks/direction when mounted in a suitable enclosure

A.6 MTBF Data

Calculations are made according to the standard MIL-HDBK217F-2 for seven types of environment:

- > Ground Benign (GB),
- > Air Inhabited Cargo (AIC),
- > Ground Fixed (GF),
- > Naval Sheltered (NS),
- > Air Rotary Wing (ARW),
- > Air Uninhabited Fighter (AUF),
- > Ground Mobile (GM).

Ground Benign (Hours)		Air Inhabited Cargo (Hours)	Ground Fixed (Hours)		Naval Sheltered (Hours)		Air Rotary Wing (Hours)	Air Uninhabited Fighter (Hours)	Ground Mobile (Hours)
25°C	40°C	40°C	30°C	55°C	25°C	40°C	55°C	40°C	30°C
565,522	408,416	96,981	223,095	143,237	120,218	102,040	28,388	42,086	84,592

A.7 Mechanical Construction

The PowerEngineC7 is a 3U, double-side, CompactPCI board. The dimensions shown below are in millimetres, with inches (in parentheses) for general guidance only.

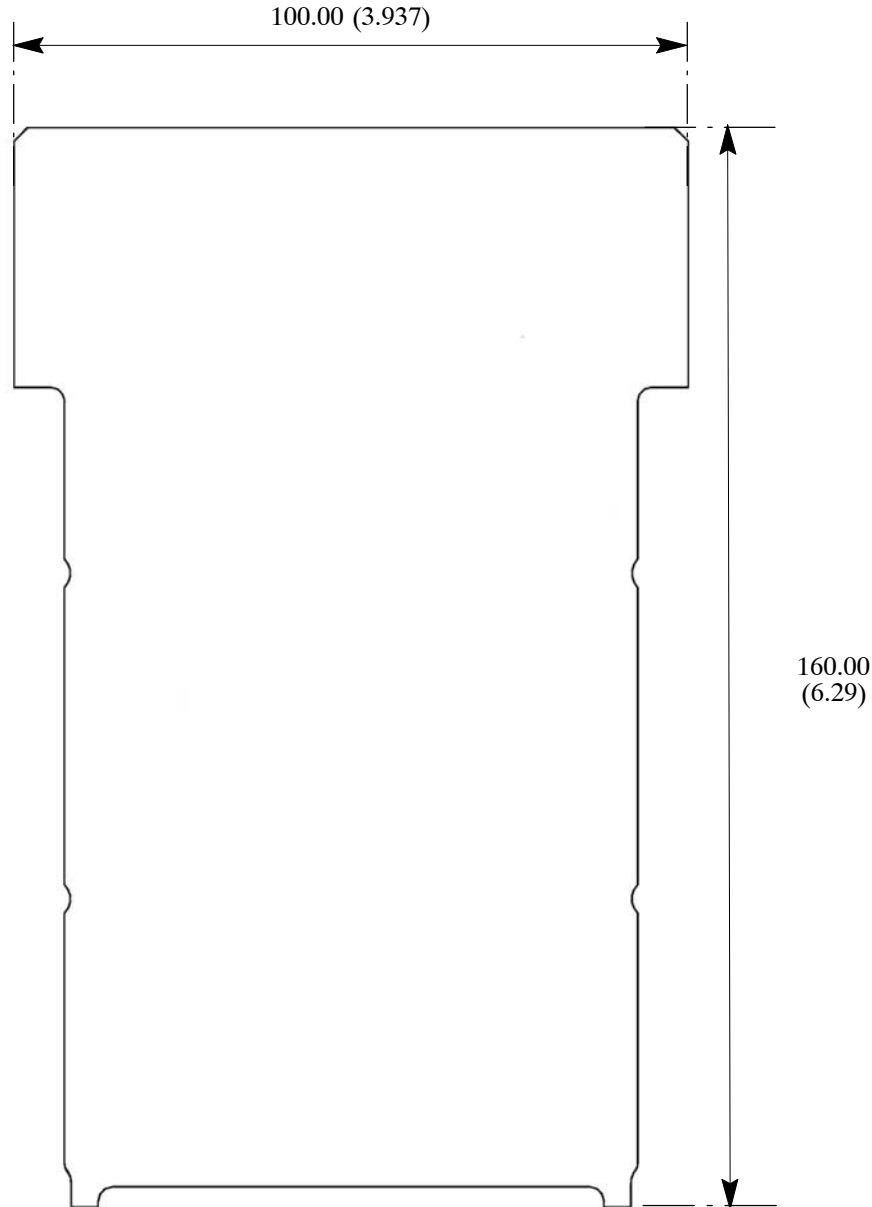

Figure 22: PowerEngineC7 Dimensions

- > Length : 100 mm
- > Depth : 160 mm (without connectors)
- > Height : 1 CompactPCI slot
- > Weight : 250 gr. approximately without ruggedizer
300 gr. approximately with the ruggedizer

Appendix B - Troubleshooting

This chapter gives some suggestions for what to do when your PowerEngineC7 doesn't work.

1. Use a step-by-step method for looking at the problem.
2. Try to diagnose the problem type (i.e. hardware or software).
3. If all else fails, phone, fax or e-mail your nearest Kontron technical support group for assistance.

B.1 Step 1 - No Power

Check that your enclosure's mains power lead is plugged into the mains outlet and into the chassis.

Check that you have switched on at the mains and at the system.

Check that you are receiving power from the mains outlet (test this with a lamp for example).

Ensure that no fuses have blown.

If the system refuses to start up, this suggests a problem with the power supply. It is essential that only qualified personnel deal with the problem from now on.

B.2 Step 2 - Power On, Unexpected Behaviour

Ensure that the board is firmly seated and secured in the rack and that all male/female connectors mate together correctly.

Check the links on the system backplane.

Check that the power supply is within CompactPCI limits on +5V, +3.3V, +12V, -12V if used on PMC with a digital voltmeter.

Check that there is only one board configured as system controller and that this is in slot 1.

Check that there are no vacant slots in the rack without jumpers (or that an automatic daisy chaining backplane is being used).

If you are still getting unexpected behaviour, try removing all other CompactPCI boards from the rack and proving the PowerEngineC7's operation in isolation, then adding a board at a time until the offending element is found.

B.3 Step 3 - Power On, No Terminal Display

Check that all cables are plugged in correctly.

If you have made your own cable, check that the pin assignment is correct.

Check that all connections are tight.

Check that the terminal is receiving power and is on.

Check that the terminal is set up for DTE (9.6 Kbaud, 8 bits/character, 1 stop bit, parity disabled) data leads only.

Check that the enclosure is not next to a radiator or other heat source.

B.4 Step 4 - PowerEngineC7 Locks-up

Ensure that your PowerEngineC7 is correctly inserted into the backplane connectors. Remove your board and re-plug it.

Try resetting the PowerEngineC7 or powering the system down and then up again.

B.5 When Phoning, Faxing or E-Mailing for Technical Support, Be Prepared To Give

- > Your name, work address, work telephone and fax numbers, and e-mail address (if appropriate)
- > A detailed description of the problem
- > Any messages and error messages being generated
- > What has been tried so far
- > The software revision level, hardware platform, hardware revision and operating system level
- > Other boards that you are using in the system with the PowerEngineC7
- > If you are reporting a bug, give detailed instructions on how to reproduce the problem and sample code, if possible (if the bug occurs in an application)

» Kontron Customer Support Service can be contacted at:

- > support-kom-sa@kontron.com

Glossary



The CompactPCI signals are detailed in chapter 5.

- ANSI** American National Standards Institute.
- ASCII** American Standard Code for Information Interchange. A 7-bit code, established by ANSI, to achieve compatibility between data services. Equivalent to the international ISO 7-bit code.
- Byte** An 8-bit data structure.
- Cache** A small, fast access memory between the processor and the larger, slower main memory. Used to store the most recently used instructions/data to improve overall memory access time.
- Chassis** See enclosure.
- Chassis Ground** Most applications require the chassis to be connected to earth, normally via a main cable or separate earthing strap.
- CPU** Central Processing Unit.
- Daisy Chain** . A signal line that propagates a signal from board to board (or chip to chip), starting with the first slot and ending at the last slot.
- DDR** Double Data Rate
- DRAM** Dynamic RAM. Memory that must be refreshed periodically to maintain the storage of information.
- ECC** Error Correcting Code. The data is protected by Error Correction Coding capable to detecting all single bit and double bit errors, and correcting single bit errors.
- EIA-232** Standard interface approved by Electronic Industries Alliance (EIA) for connecting serial devices.
- EIA-422** EIA standard for connecting serial devices. The EIA-422 is designed to replace the older EIA-232 because it supports higher data rates and greater immunity to electrical interferences. EIA-422 supports multipoint connections..
- EIA-485** EIA standard for multipoint communications. It supports several types of connectors, including DB-9 and DB-37. RS-485 is similar to RS-422 but can support more nodes per line because it uses lower-impedance drivers and receivers.
- EMC** Electro-Magnetic Compatibility.
- Enclosure** A rigid framework that provides mechanical support for boards inserted into the **backplane**, ensuring that the connectors mate properly and that adjacent boards do not touch each other. It also guides the cooling airflow through the system and ensures that inserted boards do not disengage themselves from the backplane due to vibration or shock.
- ESD** Electrostatic Sensitive Device.
- Ethernet** Ethernet is a baseband, thick-wire network based on an access method called CSMA/CD. It was originally developed by the Xerox Corporation in 1972.
- Flash Memory** A type of high-capacity E²PROM.
- FPU** Floating Point Unit.
- FTP** File Transfer Protocol. See TCP/IP.

GND	The Ground (0V) signal or supply rail.
ID	Identification.
IDSEL	Device Number.
IEEE	Institute of Electrical and Electronic Engineers.
I/O	Input/Output.
ISO	International Standards Organisation.
JTAG	Joint Test Action Group, is the usual name used for the IEEE 1149.1 standard entitled Standard Test Access Port and Boundary-Scan Architecture for test access ports used for testing printed circuit boards using boundary scan.
L2 Cache ...	Second-level cache. Often implemented outside the processor.
LED	Light Emitting Diode. A semiconductor diode that radiates light. LEDs that emit in the visible region are used as indicators or warnings.
Master	A CompactPCI master initiates bus cycles to transfer data between itself and a slave module.
Mezzanine ..	The American term for a daughter board.
MTBF	Mean Time Between Failures.
PCB	Printed Circuit Board.
PCI	Peripheral Component Interconnect.
PCI-X	Peripheral Component Interconnect addendum.
PLD	Programmable Logic Device.
PMC	PCI Mezzanine Card.
PowerEngineC7	Kontron processor 3U CompactPCI card based on the PowerPC 750FX.
Slave	A slave detects CompactPCI cycles initiated by a master and, when these cycles specify its participation, transfers data between itself and the master.
Slot	A position where a board can be inserted into a backplane .
TBD	To Be Defined.
U	The U is a standard unit of height measurement (e.g. 3U). One U is 4.445 centimetres (1.75 inches).
VCC	The five volt supply rail.

MAILING ADDRESS

Kontron Modular Computers S.A.S.
150 rue Marcelin Berthelot - BP 244
ZI TOULON EST
83078 TOULON CEDEX - France

TELEPHONE AND E-MAIL

+33 (0) 4 98 16 34 00
sales@kontron.com
support-kom-sa@kontron.com

For further information about other Kontron products, please visit our Internet web site:
www.kontron.com.