

FRONT DOOR CLOSED

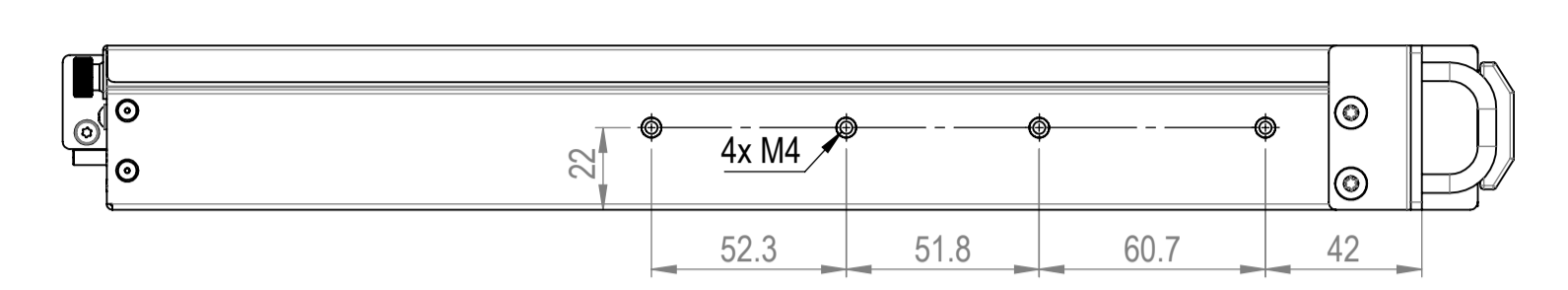

BACK VIEW

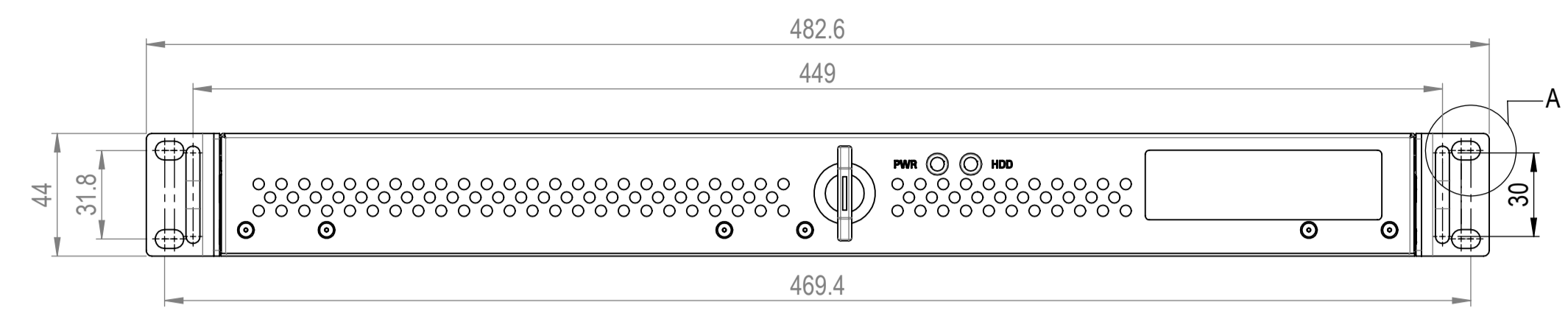
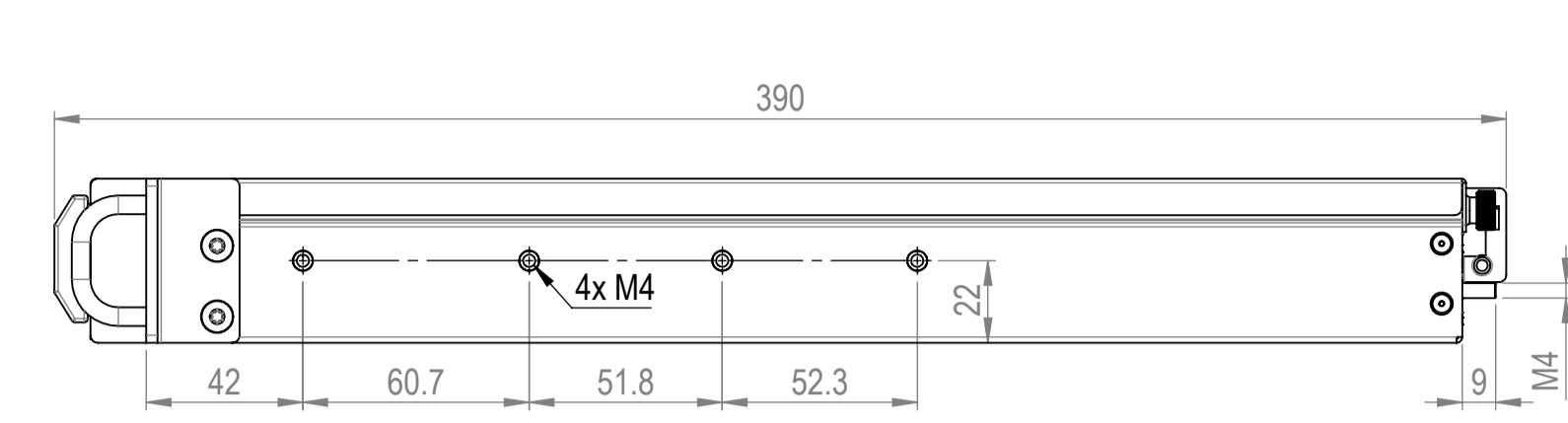
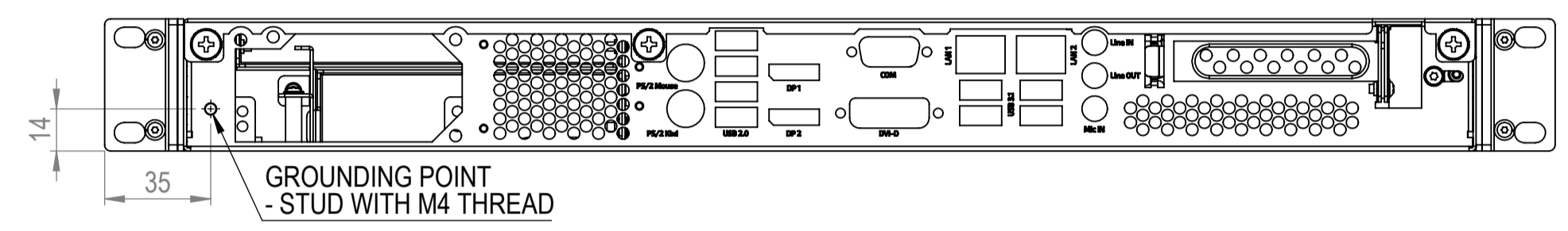

DETAIL A
SCALE 2:1

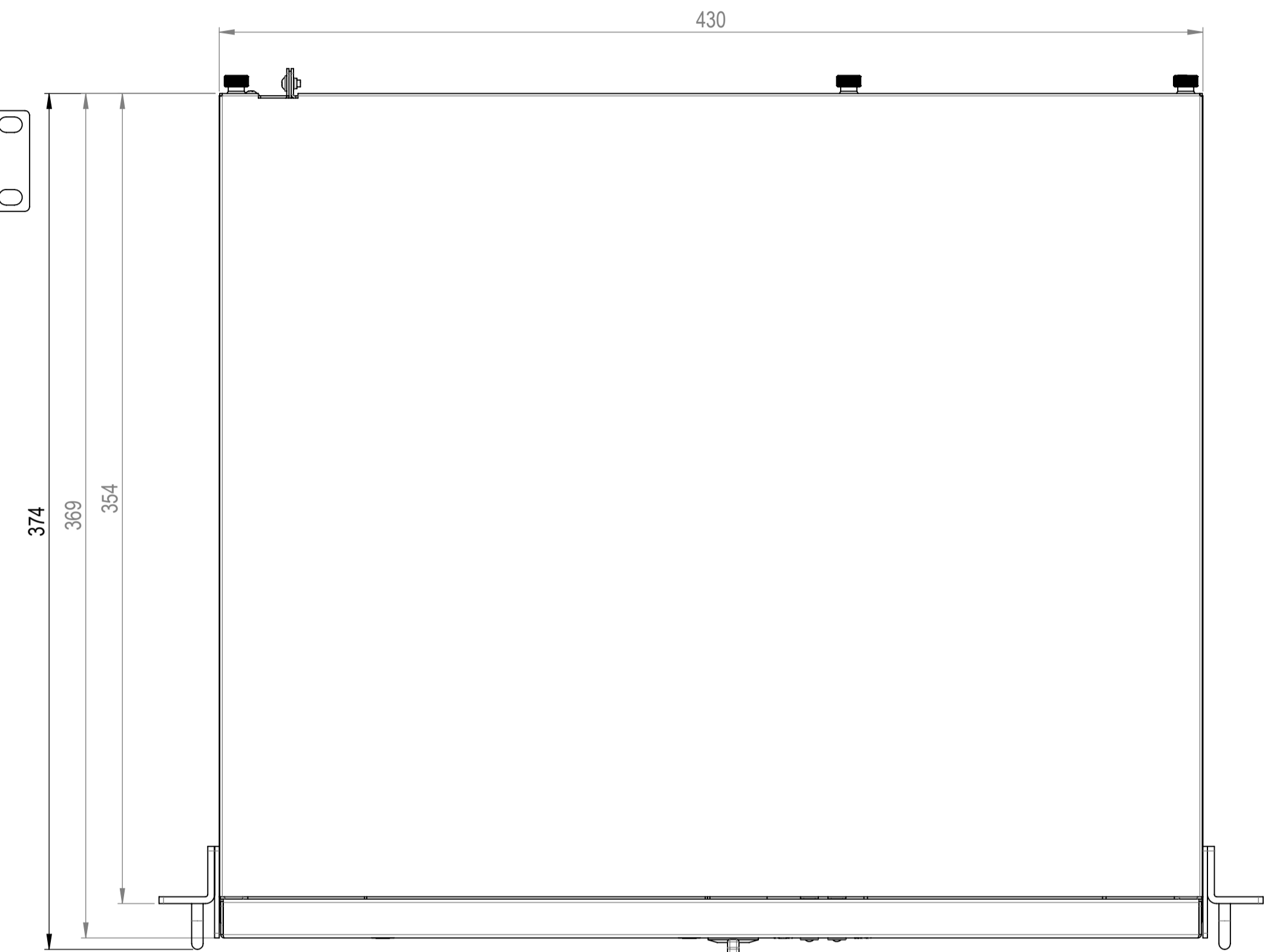
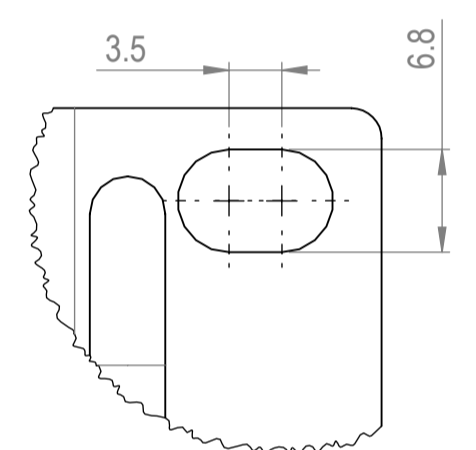

BOTTOM VIEW

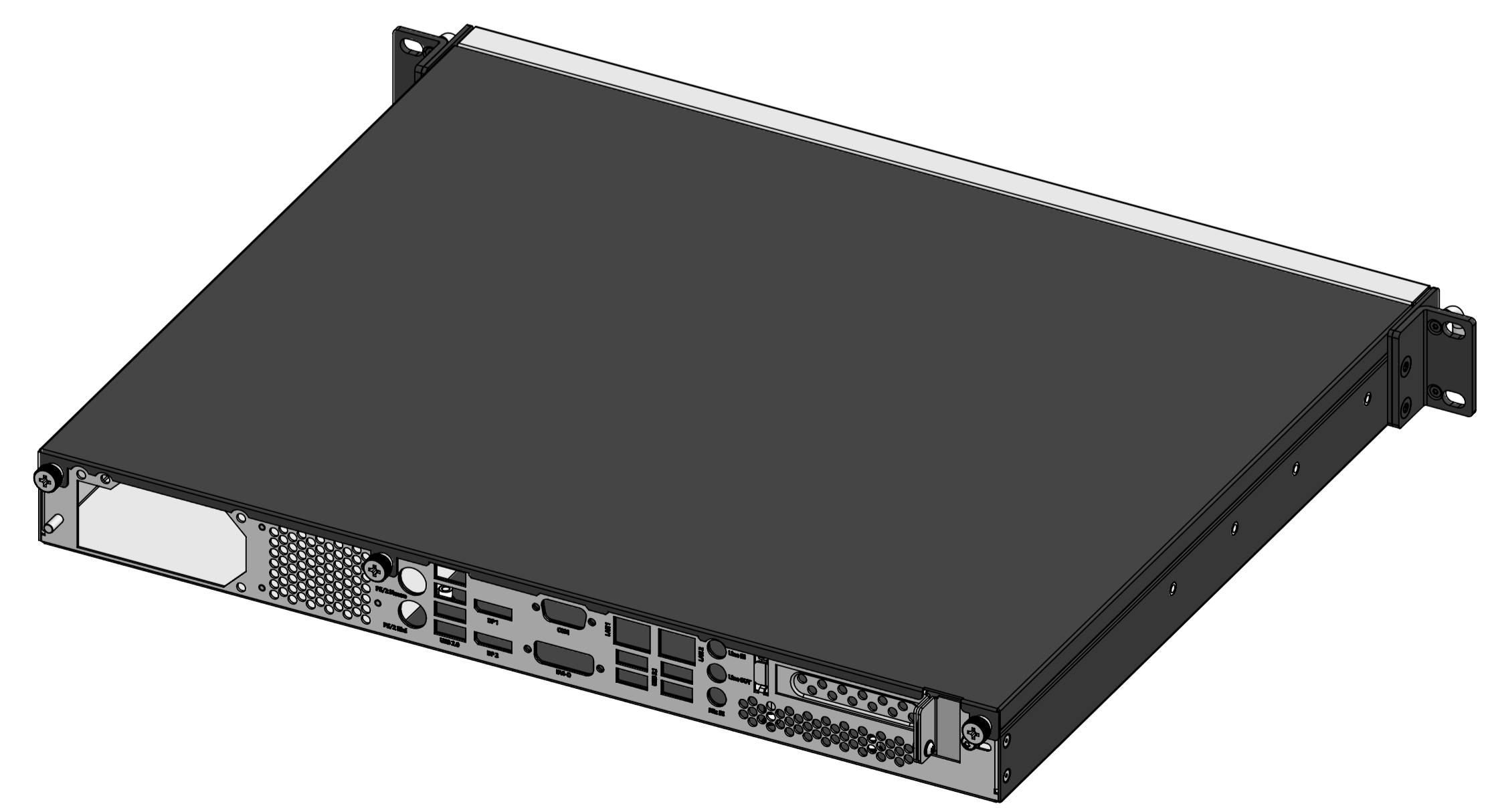
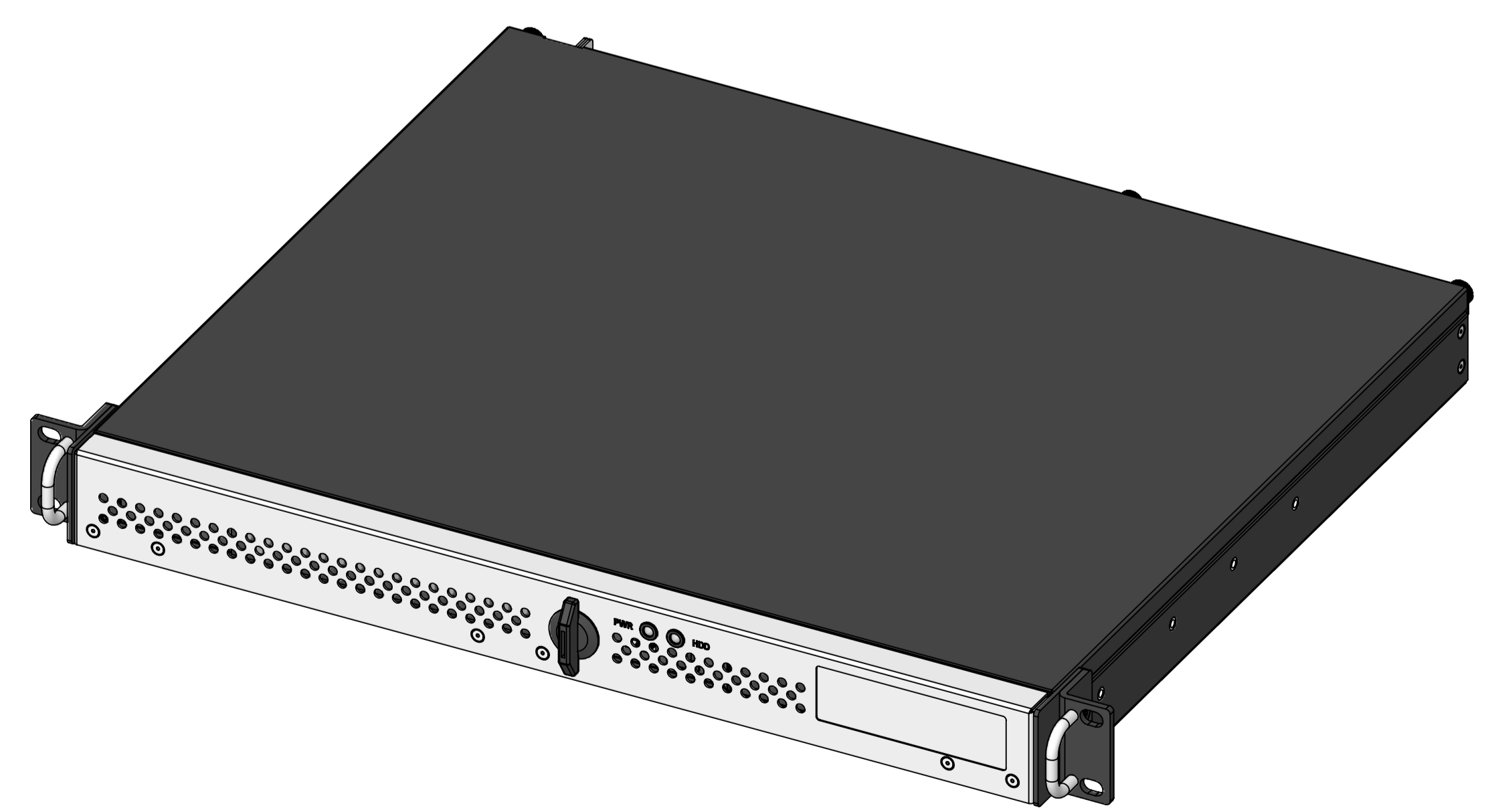
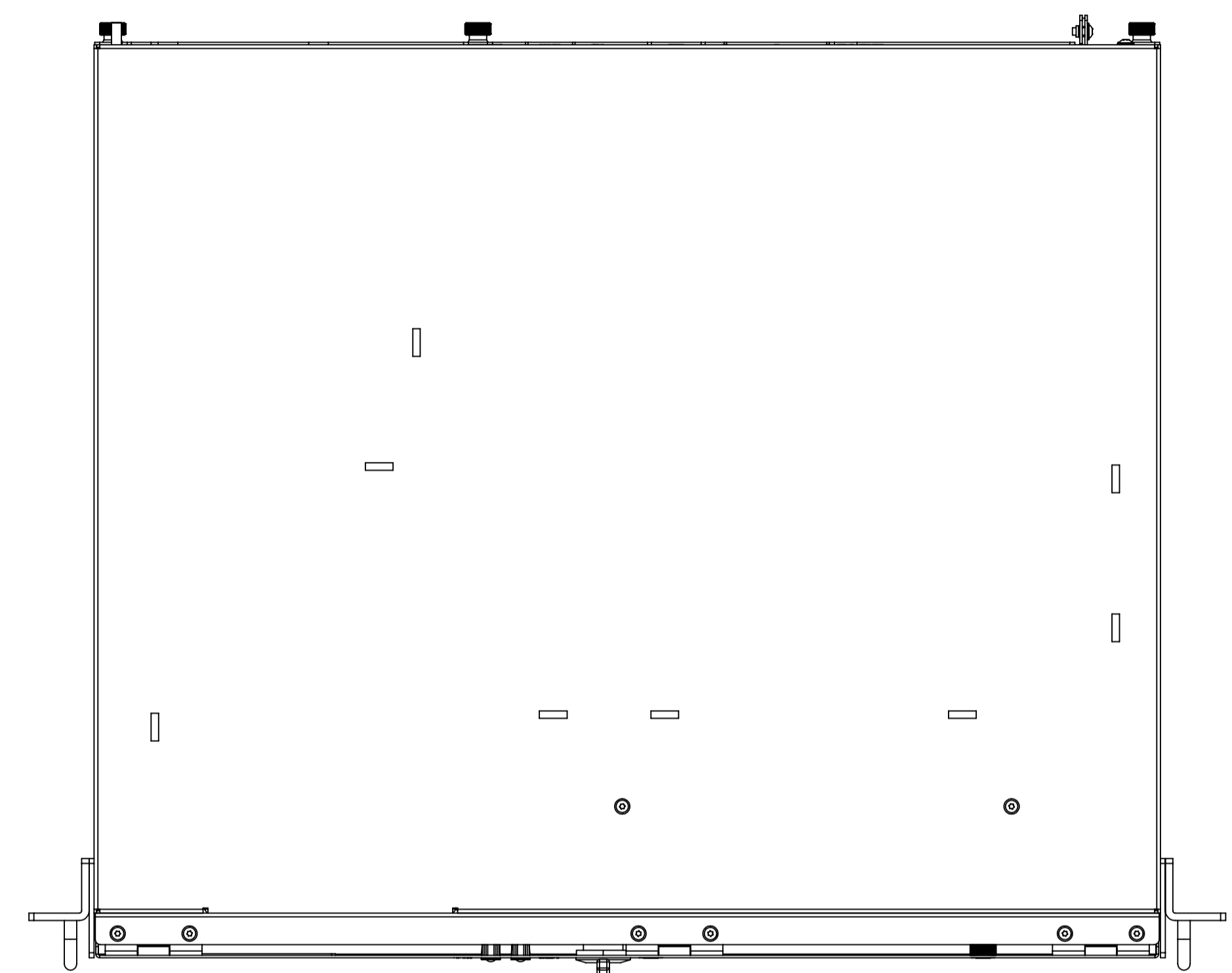

General:
Undimensioned shape according to 3D model.
Surface in visible area must be scratches free.
Normal Handling should be free from risk of injury.
Following specifications must be considered:
- Technical Procurement Specification Mechanics
- KISS 1U SHORT V3 Cosmetic Specification

TOLERANCES APPLY ONLY TO DESIGNATED DIMENSIONS, UNLESS OTHERWISE SPECIFIED:		DATE: 20.05.2019	TOLERANCES:	PART NO: 10141-099-00	PROJECT / CONTRACT NO: 60-01252
HOLE TO HOLE ±0.1mm	BEND TO HOLE ±0.2mm	DRAWN: TOMAS PASZEK	SEE TABLE	MATERIAL/FINISH:	
EDGE TO HOLE ±0.1mm	BEND TO EDGE ±0.2mm	DRAWN: TOMAS PASZEK		PART NAME: KISS 1U SHORT V3 CFL OUTLINE DRAWING	
EDGE TO EDGE ±0.2mm	BEND TO BEND ±0.2mm	APPROVED: TOMAS PASZEK		DRAWING NUMBER: 10141-099-00	
HOLE SIZE ±0.08mm	BEND ANGLE ±0.5 DEG	DATE: 20.05.2019		REVISION: A	
		DATE: 20.05.2019		ALL DIMENSIONS IN MILLIMETERS (DO NOT SCALE DRAWING)	
		DATE: 20.05.2019		SHEET: 1/2	
		DATE: 20.05.2019		SCALE: 1:2	

FRONT DOOR OPEN

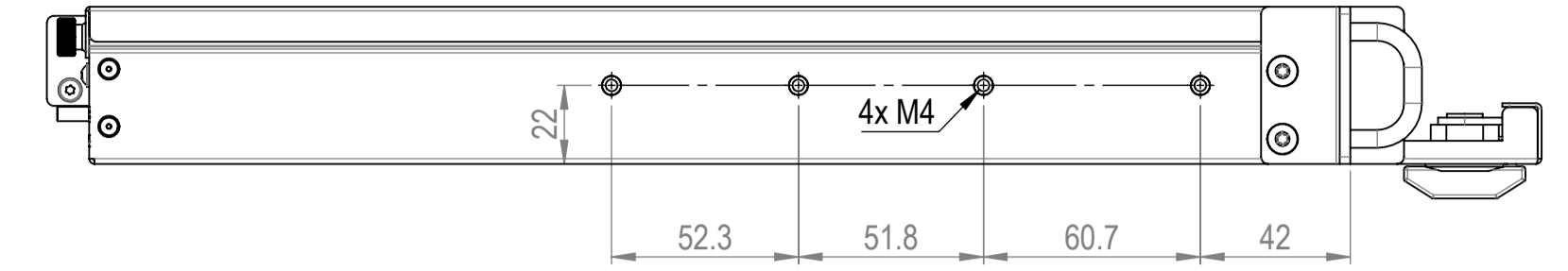
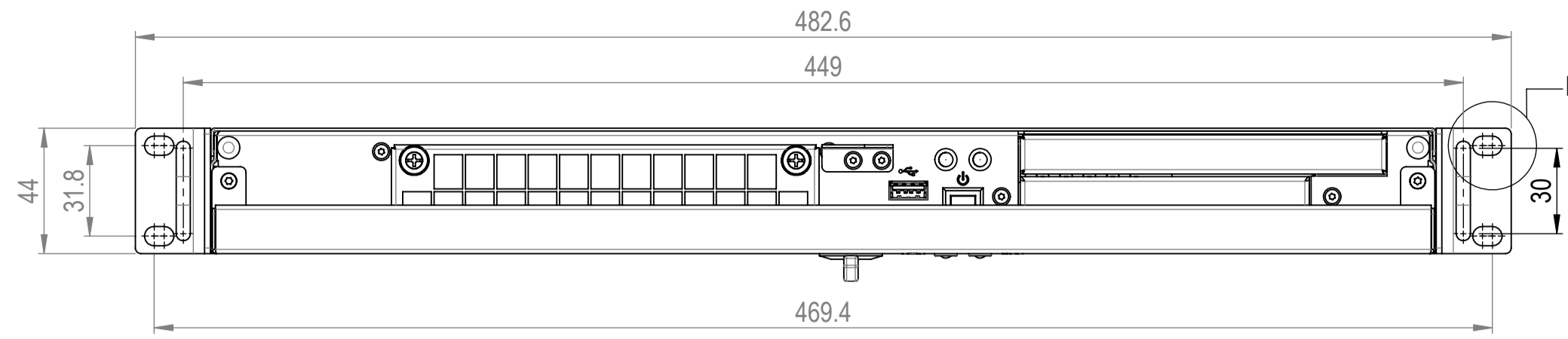
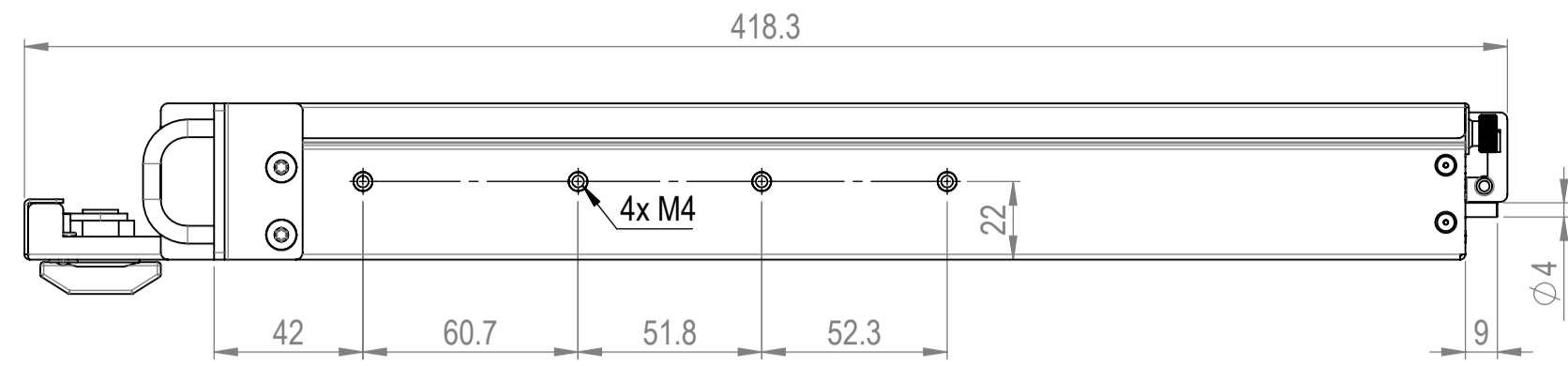

BACK VIEW

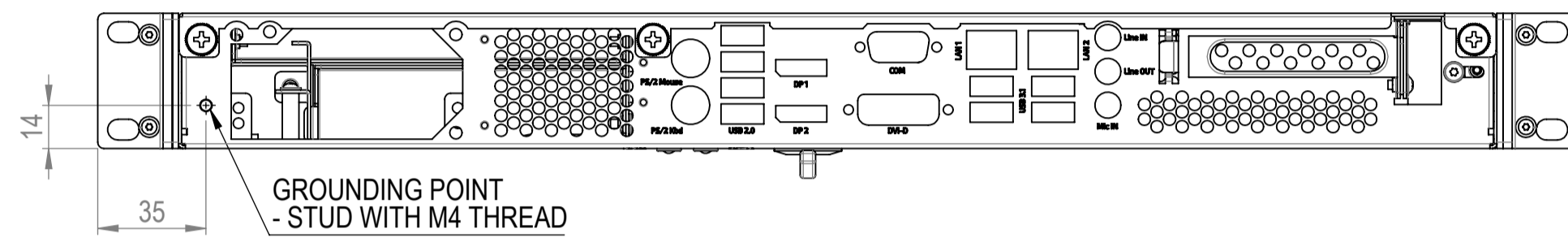

DETAIL D SCALE 2:1

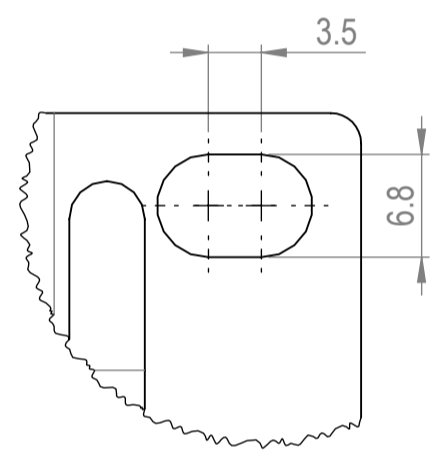

BOTTOM VIEW

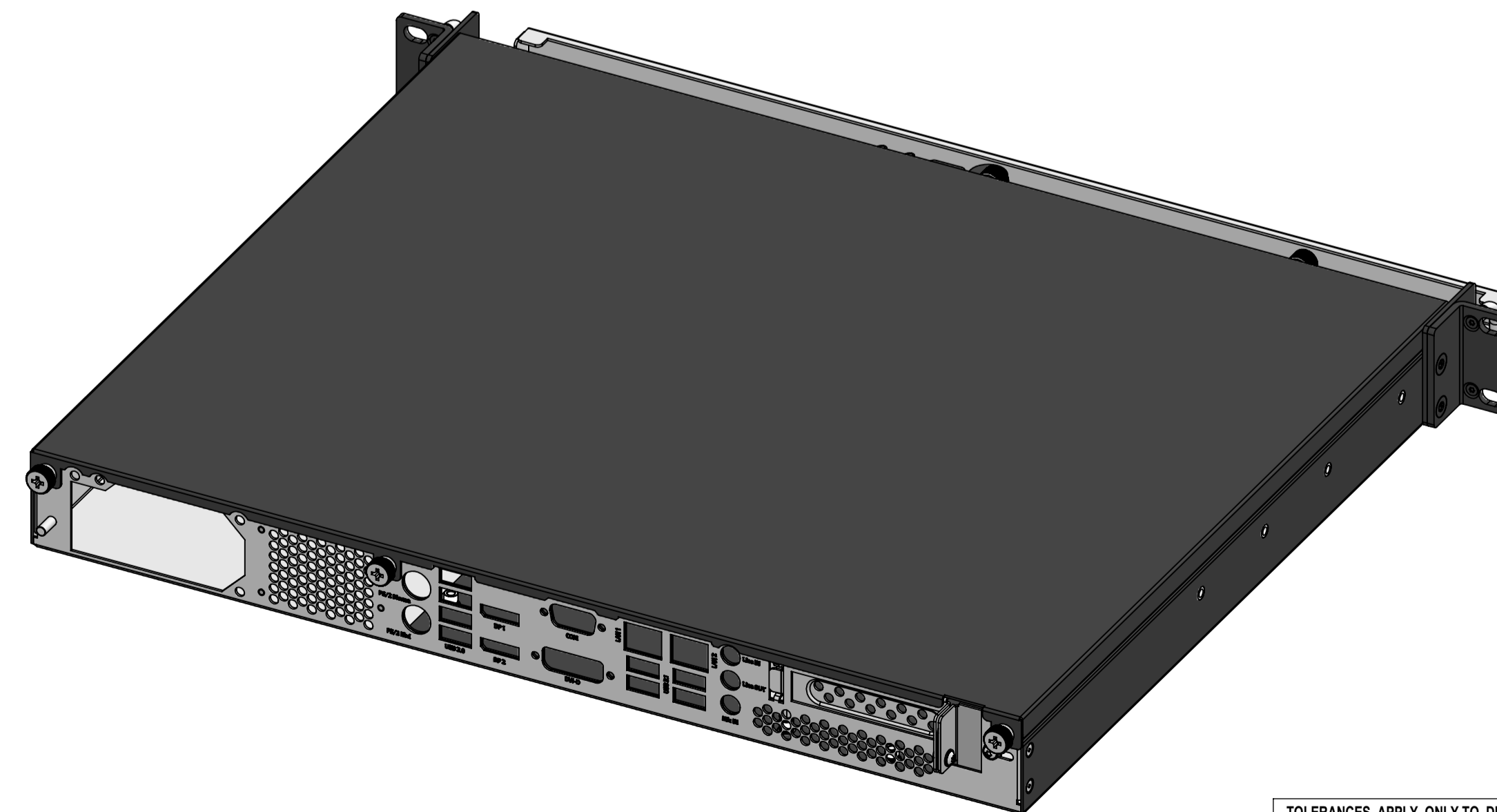
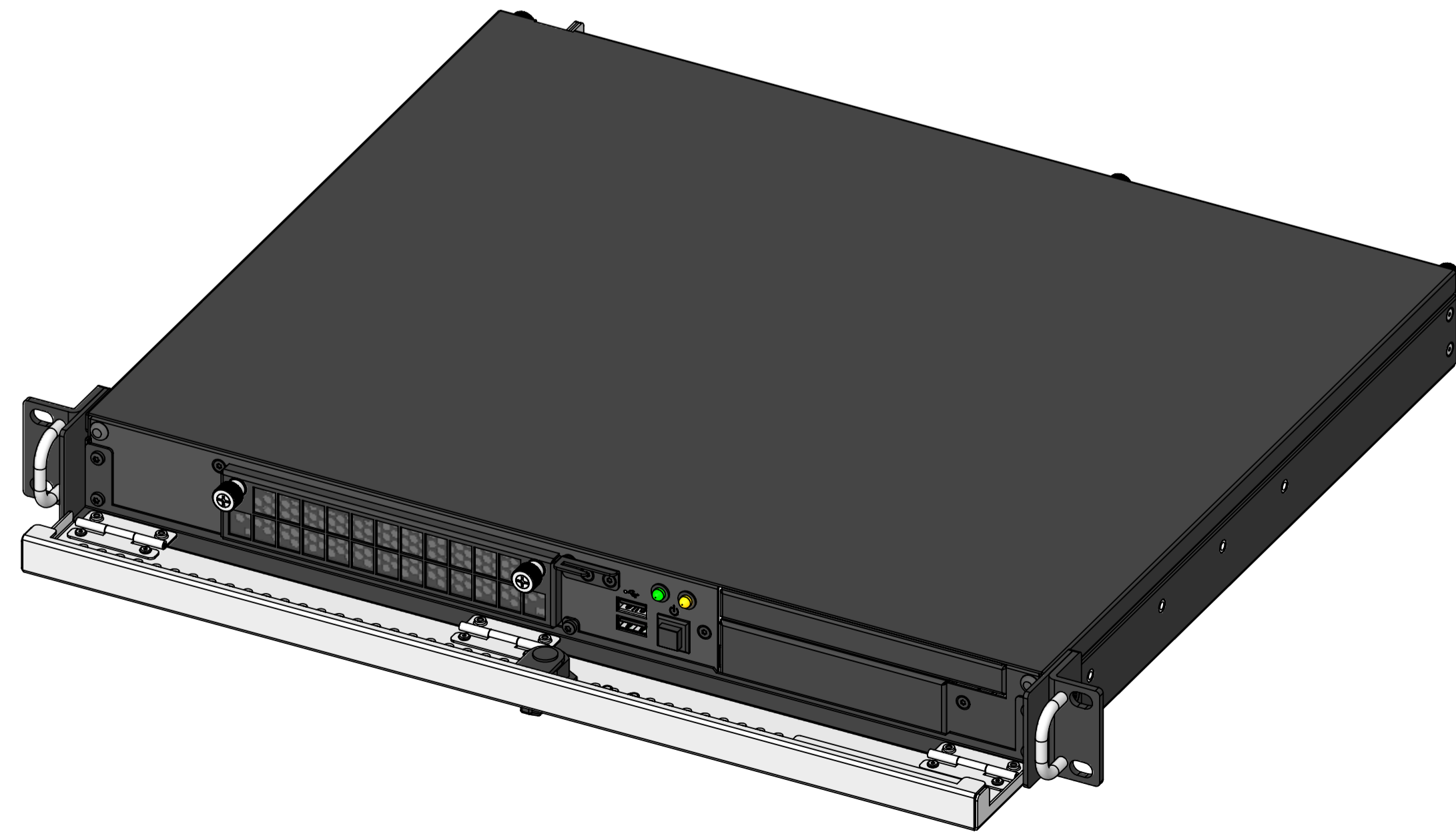
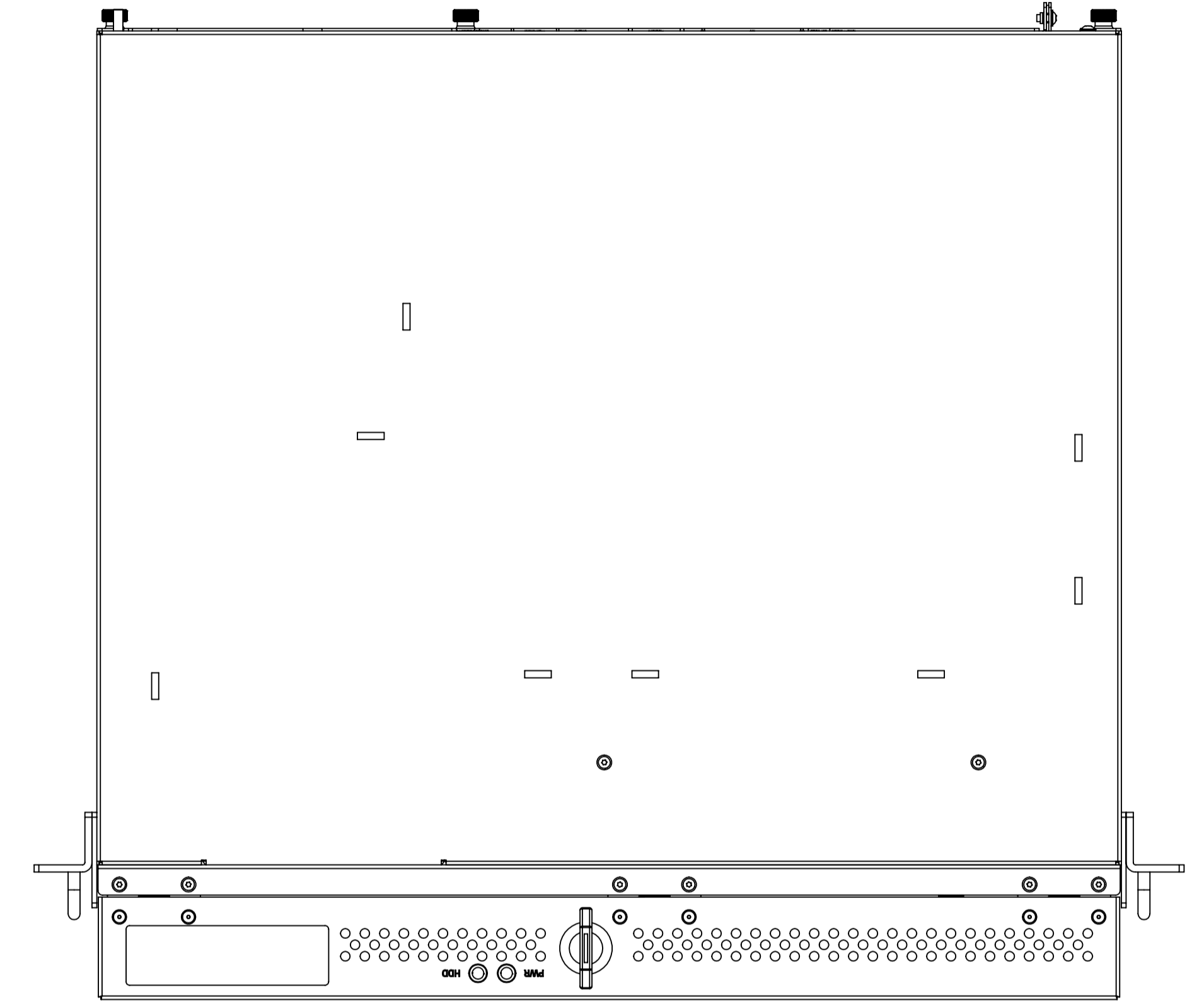
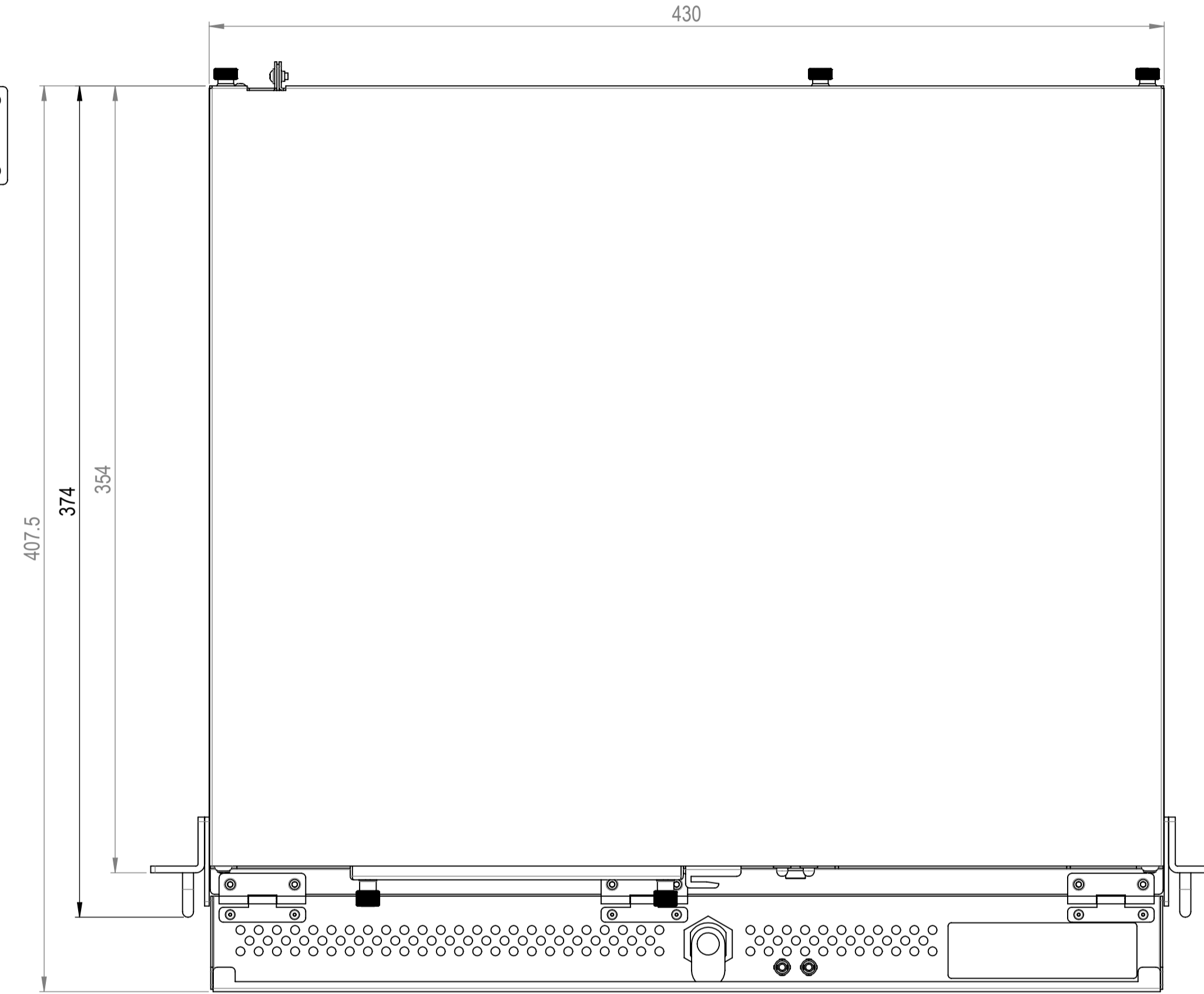

General:
 Undimensioned shape according to 3D model.
 Surface in visible area must be scratches free.
 Normal Handling should be free from risk of injury.
 Following specifications must be considered:
 - Technical Procurement Specification Mechanics
 - KISS 1U SHORT V3 Cosmetic Specification

TOLERANCES APPLY ONLY TO DESIGNATED DIMENSIONS, UNLESS OTHERWISE SPECIFIED:		DRAWN: 20.05.2019 TOMAS PASZEK		CHECKED: 20.05.2019 TOMAS PASZEK		APPROVED: 20.05.2019 TOMAS PASZEK		TOLERANCES: SEE TABLE		PART NO: 10141-099-00		PROJECT / CONTRACT NO: 60-01252	
HOLE TO HOLE ±0.1mm	BEND TO HOLE ±0.2mm	EDGE TO HOLE ±0.1mm	BEND TO EDGE ±0.2mm	EDGE TO EDGE ±0.2mm	BEND TO BEND ±0.2mm	HOLE SIZE ±0.08mm	BEND ANGLE ±0.5 DEG	ALL DIMENSIONS IN MILLIMETERS (DO NOT SCALE DRAWING)		PART NAME: KISS 1U SHORT V3 CFL OUTLINE DRAWING		DRAWN BY: ANKAPUSZEN	
										SHEET: 2/2		SCALE: 1:2	
										CONTRACT NUMBER: 10141-099-00		REVISION: A	