

Test Report

No. 300074.017
for KISS 2U 45-y, 2-A0ED-2xxx, 2-A0EE-2xxx

Test Laboratory: Kontron Embedded Computers GmbH
Oskar von Miller Straße 1
85386 Eching
Germany

Applicant: Kontron Embedded Computers GmbH

Purpose of Testing: To show compliance with:

CE EN 55022: 2006 + A1: 2007

CE EN 61000-3-2: 2000 + A2:2005

CE EN 61000-3-3: 1995 + A1: 2001 + A2:2005

CE EN 61000-4-2: 1995 + A1: 1998 + A2: 2001

CE EN 61000-4-4: 2004

CE EN 61000-4-5: 2006

CE EN 61000-4-6: 1996 + A1: 2001

CE EN 61000-4-8: 1993 + A1: 2001

CE EN 61000-4-11: 2004

Special Measurement: none
(see section "Reference Standards"
for identical national standards)

Note:

The test data of this report relate only to the individual item tested.

This report must not be reproduced unless explicitly approved by Kontron Embedded Computers GmbH.

1. Table of Contents

- 1. Table of Contents2
- 2. Administrative Data4
- 3. Summary of Test Results5
- 4. Data of Operation Mode and Configuration of EUT6
 - 4.1 Operation Mode6
 - 4.2 Configuration of Cables of EUT.....6
 - 4.3 Configuraion of EUT6
 - 4.4 Configuration of Peripherals of EUT.....7
- 5. Performed Tests and Results8
- 6. Annotations to Performed Tests and to CE certification9
- 7. Referenced Regulations19
- 8. List of Test Equipment20
 - 8.1 Radio Interference Emission Testing20
 - 8.2 Immunity Testing21
- 9. Photographs of EUT and Test Setup23
 - 9.1 Test Setup EN 55022, conducted & radiated emissions23
 - 9.2 Test Setup EN 55022, conducted emissions24
 - 9.3 Test Setup EN 61000-4-225
 - 9.4 Test Setup EN 61000-4-427
 - 9.5 Test Setup EN 61000-4-528
 - 9.6 Test Setup EN 61000-4-629
 - 9.7 Test Setup EN 61000-4-830
 - 9.8 Test Setup EN 61000-3-2; 3-3; - 4-1131
- 10. Test Report (Forms)32
 - 10.1 Test Report EN 55022 Conducted and radiated emissions32
 - 10.1.1 PSU1 - FSP400-60PFB, FSP Group Inc.32
 - 10.1.2 PSU2 - BES-630C 24VDC, Bicker47
 - 10.1.3 R1S2-5380V4V AC red., Bicker60
 - 10.2 Test Report EN 61000-3-2 Limits for harmonic current emissions PSU176
 - 10.3 Test Report EN 61000-3-2 Limits for harmonic current emissions PSU377
 - 10.4 Test Report EN 61000-3-3 Limits for Voltage Fluctuation and Flicker PSU178
 - 10.5 Test Report EN 61000-3-3 Limits for Voltage Fluctuation and Flicker PSU379
 - 10.6 Test Report EN 61000-4-2 Electrostatic Discharge Immunity test – Indirect action80
 - 10.7 Test Report EN 61000-4-2 Electrostatic Discharge Immunity test – Direct action.....81
 - 10.8 Test Report EN 61000-4-4 Electrical Fast Transients Burst Immunity test - Power Lines (Coupling Filter)
 - PSU182
 - 10.9 Test Report EN 61000-4-4 Electrical Fast Transients Burst Immunity test - Power Lines (Coupling Filter)
 - PSU283
 - 10.10 Test Report EN 61000-4-4 Electrical Fast Transients Burst Immunity test - Power Lines (Coupling Filter)
 - PSU384
 - 10.11 Test Report EN 61000-4-4 Electrical Fast Transients/Burst Immunity test - Data Lines (Coupling Clamp)85
 - 10.12 Test Report EN 61000-4-5 Surge Immunity test - Power Lines PSU186
 - 10.13 Test Report EN 61000-4-5 Surge Immunity test - Power Lines PSU287

10.14 Test Report EN 61000-4-5 Surge Immunity test - Power Lines PSU388

10.15 Test Report EN 61000-4-5 Surge Immunity test - Shielded Data Lines89

10.16 Test Report EN 61000-4-6 Immunity to Conducted Disturbances Induced by RF Fields – Power Lines PSU190

10.17 Test Report EN 61000-4-6 Immunity to Conducted Disturbances Induced by RF Fields – Power Lines PSU291

10.18 Test Report EN 61000-4-6 Immunity to Conducted Disturbances Induced by RF Fields – Power Lines PSU392

10.19 Test Report EN 61000-4-6 Immunity to Conducted Disturbances Induced by RF Fields – Data Lines93

10.20 Test Report EN 61000-4-8 Power Frequency Magnetic Field Immunity Test.....94

10.21 Test Report EN 61000-4-11 Voltage Dips, Short Interruptions and Voltage Variations Immunity Tests PSU1 95

10.22 Test Report EN 61000-4-11 Voltage Dips, Short Interruptions and Voltage Variations Immunity Tests PSU1 96

10.23 Test Report EN 61000-4-11 Voltage Dips, Short Interruptions and Voltage Variations Immunity Tests PSU1 97

10.24 Test Report EN 61000-4-11 Voltage Dips, Short Interruptions and Voltage Variations Immunity Tests PSU1 98

10.25 Test Report EN 61000-4-11 Voltage Dips, Short Interruptions and Voltage Variations Immunity Tests PSU1 99

10.26 Test Report EN 61000-4-11 Voltage Dips, Short Interruptions and Voltage Variations Immunity Tests PSU1 100

10.27 Test Report EN 61000-4-11 Voltage Dips, Short Interruptions and Voltage Variations Immunity Tests PSU3 101

10.28 Test Report EN 61000-4-11 Voltage Dips, Short Interruptions and Voltage Variations Immunity Tests PSU3 102

10.29 Test Report EN 61000-4-11 Voltage Dips, Short Interruptions and Voltage Variations Immunity Tests PSU3 103

10.30 Test Report EN 61000-4-11 Voltage Dips, Short Interruptions and Voltage Variations Immunity Tests PSU3 104

10.31 Test Report EN 61000-4-11 Voltage Dips, Short Interruptions and Voltage Variations Immunity Tests PSU3 105

10.32 Test Report EN 61000-4-11 Voltage Dips, Short Interruptions and Voltage Variations Immunity Tests PSU3 106

11. Measurement Uncertainty Values: 107

11.1 Emission Testing 107

11.2 Immunity Testing 108

2. Administrative Data

Equipment under test:	KISS 2U 45-y
<u>optional Equipment under test:</u>	none
Options/accessories:	Alteon Network ACESWITCH 180; I/O Loop back; PC Fieldworks FW8000-500
Serial number:	001
Version of EUT:	2-A0ED-2xxx, 2-A0EE-2xxx
Applicant (full address):	Kontron Embedded Computers GmbH Oskar-von-Miller-Str.1 85386 Eching, Germany
Contract identification:	--
Contact person:	K. Schiege
Manufacturer:	Kontron Embedded Computers GmbH
Receipt of EUT:	21.1.2010
Date of test:	21.1.2010 ÷ 11.3.2010
Date of report:	19.3.2010
Tested by:	Vesely P., Novak H.
Test report by:	Vesely P.

3. Summary of Test Results

- The tested sample fulfills the requirements set forth in EN 61000-6-4:2007 EMC – Part 6-4: Generic standards - Emission standard for industrial environments:

EN 55022: 2006 + A1: 2007

The tested sample fulfills the limit of class A according to EN 55022: 2006 + A1: 2007.

- The tested sample fulfills the requirements set forth in EN 61000-6-2: 2005 EMC – Part 6-2: Generic standards - Immunity for industrial environments:

EN 61000-4-2: 1995 + A1: 1998 + A2: 2001

EN 61000-4-4: 2004

EN 61000-4-5: 2006

EN 61000-4-6: 1996 + A1: 2001

EN 61000-4-8: 1993 + A1: 2001

EN 61000-4-11: 2004

No degradation of performance or loss of function is detected. The apparatus continue to operate as intended.

- The tested sample fulfills the requirements set forth in:

EN 61000-3-2: 2000 + A2: 2005

EN 61000-3-3: 1995 + A1: 2001 + A2: 2005

The tested sample fulfills all requirements for CE – Marking



Novak H.
Technical Manager



Vesely P.
Test Engineer

4. Data of Operation Mode and Configuration of EUT

4.1 Operation Mode

Special Susceptibility tests: none
Susceptibility tests: BitPro v6.0

4.2 Configuration of Cables of EUT

Unshielded and shielded data cables connected.

4.3 Configuraion of EUT

Motherboard: KTQ45/FLEX, 2xGB Intel Lan AMT 5.0, Kontron
CPU: Core2Quad Q9400 2,66GHz, Intel
Memory: DIMM 2GB DDR3 1333 MHz
Hard disk drive: Deskstar P7K500 HDP725025GLA380, HITACHI
DVD-ROM: Optiarc AD-7240S, Sony
VGA: PCIE-16 Radeon 4350 512MB passive
LAN3 card: DFE-528TX PCI, D-LINK
Power supply1: FSP400-60PFB, FSP Group Inc.
Power supply2: BES-630C 24VDC, Bicker
Power supply3: R1S2-5380V4V red., Bicker
Operating systems: WinXP SP3

4.4 Configuration of Peripherals of EUT

<u>Used Accessories:</u>	<u>Cable length:</u>
Monitor1, LG 23":	1,5m
Monitor2, Kontron 18" PM-EM-9509.01:	1,5m
PS/2 Keyboard PM-EM-9589.01; -9598.01:	1,5m
PS/2 Mouse PM-EM-9595.01; -8525.01:	1,5m
USB Keyboard:	1,5m
USB Mouse Microsoft:	1,5m
USB Floppy1 PM-EM-9594.01:	0,5m
USB CD-ROM Teac:	0,5m
USB HDD1 PM-EM-9516.01:	1,5m
USB/FireWire HDD2 PM-EM-9513.01:	1,5m
USB CD-ROM1 Amacom:	0,5m
USB CD-ROM2 Amacom:	0,5m
USB CD-ROM3 Amacom:	0,5m
<u>Unshielded cables:</u>	
Power Cord	1.7 m
<u>Shielded cables:</u>	
USB1 – USB8:	1,5 m
FireWire1:	3 m
Ethernet1 – Ethernet3:	3 m
COM1 – COM2:	1,5 m
LPT:	1,5 m
VGA:	1,5 m
DVI:	3 m
Headset:	1,5 m

5. Performed Tests and Results

Test	Classification/Result-CE	Note
EN 55022: 2006 + A1: 2007	The requirements are fulfilled for CE certification see point 6.	Conducted Emissions – see below Radiated emissions – see below
EN 61000-3-2: 2000 + A2: 2005	The requirements are fulfilled for CE certification see point 6.	PASS
EN 61000-3-3: 1995 + A1: 2001 + A2: 2005	The requirements are fulfilled for CE certification see point 6.	PASS
EN 61000-4-2: 1995 + A1: 1998 + A2: 2001	The requirements are fulfilled for CE certification see point 6.	Temporary degradation or loss of function or performance (criterion B according to EN 61000-6-2: 2005)
EN 61000-4-4: 2004	The requirements are fulfilled for CE certification see point 6.	Temporary degradation or loss of function or performance (criterion B according to EN 61000-6-2: 2005)
EN 61000-4-5: 2006	The requirements are fulfilled for CE certification see point 6.	Temporary degradation or loss of function or performance (criterion B according to EN 61000-6-2: 2005)
EN 61000-4-6: 1996 + A1: 2001	The requirements are fulfilled for CE certification see point 6.	No temporary degradation or loss of function or performance (criterion A according to EN 61000-6-2: 2005)
EN 61000-4-8: 1993 + A1: 2001	The requirements are fulfilled for CE certification see point 6.	No temporary degradation or loss of function or performance (criterion A according to EN 61000-6-2: 2005)
EN 61000-4-11: 2004	The requirements are fulfilled for CE certification see point 6.	Temporary degradation or loss of function or performance (criterion B & C according to EN 61000-6-2: 2005)

6. Annotations to Performed Tests and to CE certification

EMC-CE Basic Standards

EN 61000-6-3 + EN 61000-6-4 ... Generic emission standards

EN 61000-6-1 + EN 61000-6-2 ... Generic immunity standards

IEC 61000-3-2 (EN 61000-3-2)

Limits for harmonic current emissions (equipment input current less than or equal to 16 A per phase; $\leq 75\text{W}$) PowerFactorCorrector

IEC 61000 PT3-3 (EN 61000-3-3)

Limits for voltage fluctuation and flicker for equipment with rated current $\leq 16\text{ A}$ / $\leq 75\text{ W}$ PowerFactorCorrector

IEC 61000 PT4-2, ESD (EN 61000-4-2)

$\pm 4\text{ kV}$ Contact, $\pm 8\text{ kV}$ Air, Criterion B

IEC 61000 PT4-4, BURST (EN 61000-4-4)

$\pm 2\text{ kV}$ DC/DC PSUs, Criterion B

$\pm 2\text{ kV}$ AC/DC PSUs, Criterion B

$\pm 1\text{ kV}$ data and control cables longer than 3 m (KONTRON longer than 1.5m), Criterion B

IEC 61000 PT4-5, SURGE (EN61000-4-5)

With AC input/output lines, the EUT undergoes five positive as well as five negative impulses

DC In/Output $\pm 0.5\text{ kV}$ common and differential mode

AC Input port: $\pm 1\text{ kV}$ differential / $\pm 2\text{ kV}$ common mode

data cables $\pm 1\text{ kV}$ common mode, all cables longer than 30m (KONTRON longer than 3m), criterion B

(symmetrically and asymmetrically) at 90° , the same at 180° and at 270° .

IEC 61000 PT4-6, Radio-frequency common mode (EN 61000-4-6)

Refers to the conducted immunity requirements of electrical and electronic equipment to electromagnetic disturbance from intended radio-frequency (RF) transmitters in frequency range 150 kHz to 230MHz. Does not include equipment not having at least one conducting cable (i.e. mains supply, signal line or earth connection) which can couple the equipment to the disturbing RF.

Power lines and data lines: 10 V, 0.15-230 MHz, 80% AM, Criterion A

IEC 61000 PT4-8, Magnetic field (EN 61000-4-8)

50 Hz, 30 A/m only for system which have parts, they can be influenced by magnetic field.
Criterion A (for Monitor H>3A/m Criterion A)

IEC 61000 PT4-11, Voltage dips (EN61000-4-11)

Voltage dips, short interruptions and voltage variations immunity tests

AC Input: 30% - 10ms reduction, Criterion B

60% - 100ms and 1000ms reduction, Criterion C

>95% - 5000ms reduction, Criterion C

EN 55022 / CISPR 22

Conducted Emission Limit (at the mains):

Class A:	0,15 - 0,50 MHz	QP: 79	AV: 66 dBμV
	0,50 - 30,0 MHz	QP: 73	AV: 60 dBμV
Class B:	0,15 - 0,50 MHz	QP: 66 - 56	AV: 56 - 46 dBμV
	0,50 - 5,0 MHz	QP: 56	AV: 46 dBμV
	5,0 - 30,0 MHz	QP: 60	AV: 50 dBμV

Conducted Emission Limit (at the telecom terminal port):

Class A:	0,15 - 0,50 MHz	QP: 53 - 43	AV: 40 - 30 dBμA
	0,50 - 30,0 MHz	QP: 43	AV: 30 dBμA
Class B:	0,15 - 0,50 MHz	QP: 40 - 30	AV: 30 - 20 dBμA
	0,50 - 30,0 MHz	QP: 30	AV: 20 dBμA

Radiated Emission (for the **1m KONTRON** distance, hitch with **+10 dB** (μ V/m))

Class A:	30 - 230 MHz	40 dB(μV/m)/58,5	10m/1m
	230 - 1000 MHz	47 dB(μV/m)/58,5	10m/1m
Class B:	30 - 230 MHz	30 dB(μV/m)/48,5	10m/1m
	230 - 1000 MHz	37 dB(μV/m)/48,5	10m/1m

Measurement conditions according to CISPR 22 1997/ Amendment 1:

General measurement conditions

A test site shall permit disturbances from the EUT to be distinguished from ambient noise. The suitability of the site in this respect can be determined by measuring the ambient noise levels with the EUT inoperative and ensuring that the noise level is at least 6 dB below the limits specified in clauses 5 and 6.

If at certain frequency bands the ambient noise is not 6 dB below the specified limit, the methods shown in 10.4 may be used to show compliance of the EUT to the specified limits.

It is not necessary that the ambient noise level be 6 dB below the specified limit where both ambient noise and source disturbance combined do not exceed the specified limit. In this case the source emanation is considered to satisfy the specified limit. Where the combined ambient noise and source disturbance exceed the specified limit, the EUT shall not be judged to fail the specified limit unless it is demonstrated that, at any measurement frequency for which the limit is exceeded, two conditions are met:

- a) the ambient noise level is at least 6 dB below the source disturbance plus ambient noise level;
- b) the ambient noise level is at least 4,8 dB below the specified limit.

EUT configuration

Where not specified herein, the EUT shall be configured, installed, arranged and operated in a manner consistent with typical applications. Interface cables/loads/devices shall be connected to at least one of each type of interface port of the EUT, and where practical, each cable shall be terminated in a device typical of actual usage.

Where there are multiple interface ports of the same type, additional interconnecting cables/loads/devices may have to be added to the EUT depending upon the results of preliminary tests. The number of additional cables should be limited to the condition where the addition of another cable does not decrease the margin a significant amount (for example 2 dB) with respect to the limit. The rationale for the selection of the configuration and loading of ports shall be included in the test report.

Interconnecting cables should be of the type and length specified in the individual equipment requirements. If the length can be varied, the length shall be selected to produce maximum disturbance.

If shielded or special cables are used during the tests to achieve compliance, then a note shall be included in the instruction manual advising of the need to use such cables.

Excess lengths of cables shall be bundled at the approximate centre of the cable with the bundies 30 cm to 40 cm in length. If it is impractical to do so because of cable bulk or stiffness, or because the testing is being done at a user installation, the disposition of the excess cable shall be precisely noted in the test report.

Where there are multiple interface ports all of the same type, connecting a cable to just one of that type of port is sufficient, provided it can be shown that the additional cables would not significantly affect the results.

Any set of results shall be accompanied by a complete description of the cable and equipment orientation so that results can be repeated. If specific conditions of use are

required to meet the limits, those conditions shall be specified and documented; for example cable length, cable type, shielding and grounding. These conditions shall be included in the instructions to the user.

Equipment which is populated with multiple modules (drawer, plug-in card, board, etc.) shall be tested with a mix and number representative of that used in a typical installation. The number of additional boards or plug-in card actually used should be limited to the number for which the addition of another board or card does not decrease the margin a significant amount (for example 2 dB) with respect to the limit. The rationale used for selecting the number and type of modules should be stated in the test report.

A system that consists of a number of separate units shall be configured to form a minimum representative configuration. The number and mix of units included in the test configuration shall normally be representative of that used in a typical installation. The rationale used for selecting units should be stated in the test report.

Examples of a minimum representative configuration follow.

For a personal computer or a personal computer peripheral, the minimum configuration consists of the following device grouped and tested together:

- a) personal computer;
- b) keyboard;
- c) visual display unit;
- d) external peripheral for each of two different types of available I/O protocols, such as serial, parallel, etc.;
- e) if the EUT has a dedicated port for a special-purpose device such as a mouse or joystick, that device shall be part of the minimum configuration.

NOTE - Items a), b) and/or c) may, in some systems, be assembled in the same chassis. In no instance may items a), b), c) mouse or joystick controls, be used as a replacement for item d).

For a point of sale terminal, the minimum system consists of the following devices (to the extent applicable) grouped and tested together:

- a) active processor (till);
- b) cash drawer;
- c) keyboard(s);
- d) display units (operator and customer);
- e) typical peripheral (bar code scanner);
- f) handheld device (bar code scanner).

One module of each type shall be operative in each ITE evaluated in an EUT. For a system EUT, one of each type of ITE that can be included in the possible system configuration shall be included in the EUT.

A unit of equipment which forms part of a system distributed over a wide area (such as data processing terminals or workstations, or private branch telecommunication exchanges, etc.), and which in itself may be a subsystem, may be tested independently of the host unit or system. Distributed networks, for example a local area network, may be simulated on the test site by lengths of cable and actual peripherals or remote network communications simulators located at a distance sufficient to ensure that they do not contribute to the measured level.

The results of an evaluation of EUTs having one of each type of module or ITE can be applied to configurations having more than one of each of those modules or ITE. This is permissible because it has been found that disturbances from identical modules or ITE (see 3.5) are generally not additive in practice.

In the case of EUTs which functionally interact with other ITE, including any ITE that is dependent on a host unit for its power interface, either the actual interfacing ITE or simulators may be used to provide representative operating conditions, provided the effects of the simulator can be isolated or identified. If an ITE is designed to be a host unit to other ITE, such ITE may have to be connected in order that the host unit shall operate under normal conditions.

It is important that any simulator used instead of an actual interfacing ITE properly represents the electrical and, in some cases, the mechanical characteristics of the interfacing ITE, especially RF signals and impedances. Following this procedure will permit the results of measurements of individual ITE to remain valid for system application and integration of the ITE with other similarly tested ITE, including ITE produced and tested by different manufacturers.

In the case of printed wiring board assemblies (PWBA), separately marketed for the enhancement of diverse host units, the PWBA (such as ISDN interface, CPU, adaptor cards, etc.) shall be tested in at least one appropriate representative host unit of the PWBA manufacturer's choice so as to ensure compliance of the PWBA with the entire population of hosts in which it is intended to be installed.

The host shall be a typical compliant production sample.

PW BA intended to be class B shall not be tested in hosts which are class A.

The accompanying documentation of the PWBA shall include information regarding the host units in which the PW BA was tested and verified, and information enabling the user to identify host units in which the PW BA will achieve compliance with the classification (A or B).

Determination of maximum emission configuration(s)

Initial testing shall identify the frequency that has the highest disturbance relative to the limit while operating the EUT in typical modes of operation and cable positions in a test set-up which is representative of typical system configurations. The identification of the frequency of highest disturbance with respect to the limit shall be found by investigating disturbances at a number of significant frequencies, to give confidence that the probable frequency of maximum disturbance has been found and that the associated cable, EUT configurations and mode of operation has been identified.

For initial testing, the EUT shall be set up in accordance with figures 4 through 14. The distances between the EUT and peripherals are set according to the figures.

Final measurements shall be conducted as in clauses 9 and 10 for terminal disturbance voltage and disturbance field strength measurements, respectively.

Operation of the EUT

The EUT shall be operated within the rated (nominal) operating voltage range and typical load conditions (mechanical or electrical) for which it is designed. Actual loads should be used whenever possible. If a simulator is used, it shall represent the actual load with respect to its radio frequency and functional characteristics.

The test programs or other means of exercising the equipment should ensure that various parts of a system are exercised in a manner that permits detection of all system disturbances. For example, in a computer system, tape and disk drives should be put through a read-write erase sequence; and various portions of memories should be addressed. Any mechanical activities should be performed and visual display units should be operated as in 8.2.1.

Operation of visual display units

If the EUT includes a visual display or monitor, the following operating rules shall be used.

- Set the contrast control to maximum.
- Set the brightness control to maximum or at raster extinction if raster extinction occurs at less than maximum brightness.
- For color monitors, use white letters on a black background to represent all colors. - Select the worse case of positive or negative video if both alternatives are available.
- Set character size and number of characters per line so that typically the greatest number of characters per screen is displayed.
- For monitors with graphics capabilities, a pattern consisting of all scrolling Hs should be displayed. For monitors with text only capability, a pattern consisting of random text shall be displayed. If neither of the above apply, use a typical display.

The EUT shall be operated in the operating mode that generates the greatest level of emission while satisfying the above operating rules.

Measurement at telecommunication ports

The EUT shall be set up in accordance with figures 4 through 9 for tabletop equipment, floorstanding equipment, and combined floor-standing equipment and tabletop equipment.

In order to make reliable emission measurements representative of high LAN utilization it is only necessary to create a condition of LAN utilization in excess of 10 % and sustain that level for a minimum of 250 ms. The content of the test traffic should consist of both periodic and pseudo-random messages in order to emulate realistic types of data transmission (e.g. random: files compressed or encrypted; periodic: uncompressed graphic files, memory dumps, screen updates, disk images). If the LAN maintains transmission during idle periods measurements shall also be made during idle periods (see clause E.3, [7]).

Current measurements at telecommunication ports intended for connection to screened cables or to coaxial cables. Test set-up for common mode measurements C.1.2 Using a 150 Ω load to the outside surface of the shield ("in situ CDN/ISN").

- Break the insulation and connect a 150 Ω resistor from the outside surface of the shield to ground.
- Apply a ferrite tube or clamp between 150 Ω connection and AE.
- Measure current with a current probe and compare to the current limit. The common mode impedance towards the right of the 150 Ω resistor shall be sufficiently large as not to affect the measurement. Use clause C.2 to measure this impedance which should be much greater than 150 Ω so as not to affect the measurement for frequencies emitted by the EUT.

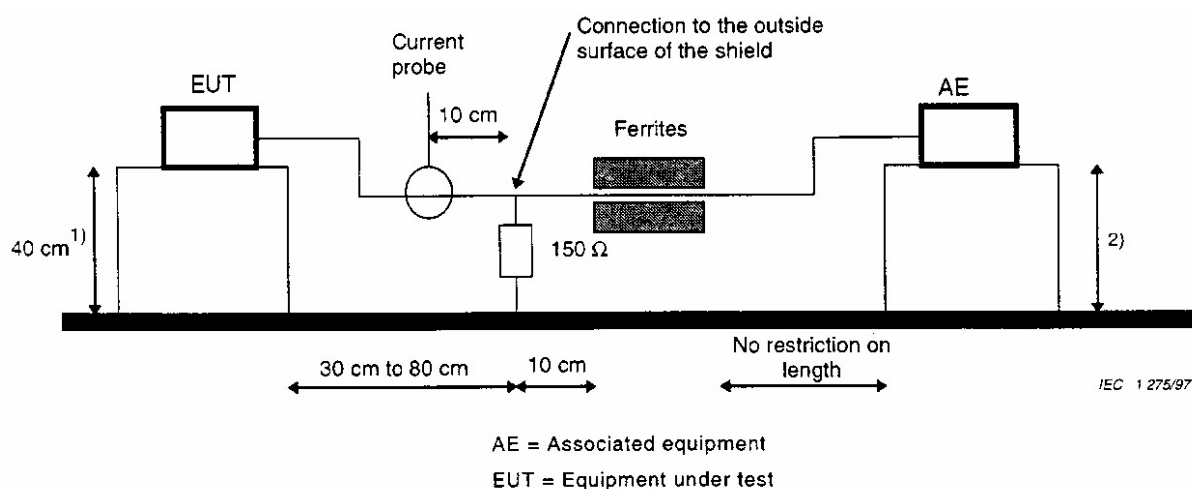

¹⁾ Distance to the reference groundplane (vertical or horizontal).

²⁾ Distance to the reference groundplane is not critical.

Figure C.2

Short description of some performed tests:

ESD EN 61000-4-2

At each test point 10 positive and 10 negative pulses are applied with a recovery time of at least 1 s.

Burst EN 61000-4-4

Each AC/DC input/output line of the EUT undergoes with each single line and also all lines together of one port (N, L1, PE, GND) positive as well as negative impulses for 2 minutes each.

Each DATA line of the EUT undergoes positive as well as negative impulses for 2 minutes each.

The test procedure is executed for every test level up to the highest test level. Test is executed up to the highest specified test level (250 V or 500 V or 1000 V or 2000 V or 4000 V). Higher levels include all lower levels, i.e. if a 2000 V test is performed, a 250 V, a 500 V and a 1000 V test must also be performed.

Surge EN 61000-4-5

With AC input/output lines, the EUT undergoes five positive as well as five negative impulses (symmetrically and asymmetrically) at 90°, the same at 180° and at 270°.

DC input/output lines, data lines and shielded lines undergo five positive as well as five negative impulses. DC input/output lines and data lines are tested symmetrically and asymmetrically.

The test procedure is executed for every test level up to the highest test level. Test is executed up to the highest specified test level (500 V or 1000 V or 2000 V or 4000 V). Higher levels include all lower levels, i.e. if a 2000 V test is performed, a 500 V and a 1000 V test must also be performed. Recovery time between the pulses is 60 seconds.

Conducted disturbances induced by Radio Frequency field EN 61000-4-6

Attempts should be made to fully exercise the EUT during testing, and to fully interrogate all exercise modes selected for susceptibility. The frequency range is swept from 150 KHz to 230 MHz, using the signal levels established during the setting process, and with the disturbance signal 80% amplitude modulated with a 1 KHz sine wave, pausing to adjust the RF-signal level or to switch coupling devices as necessary. The rate of sweep shall not exceed 1.5×10^{-3} decades/s. Where the frequency is swept incrementally, the step size shall not exceed 1 % of the start and thereafter 1 % of the preceding frequency value.

Immunity Testing with LF Magnetic Fields EN 61000-4-8

This test method describes immersion of the EUT by a continuous LF magnetic field, obtained by a current of power frequency flowing in an induction coil. The test equipment needed for this test includes a current source, the induction coil, and auxiliary test instrumentation. The test setup requires a nonmagnetic ground plane under the EUT of at least 1 x 1 m. The equipment is to be placed on the ground plane with an insulating support.

Depending on the size of the EUT, induction coils of different dimensions may be used. The dimensions recommended are to produce a magnetic field in the whole volume of the EUT within +3 dB. For small EUTs, like terminals and instruments, a square-shaped or circular coil of 1 m side or diameter is recommended. The double coils of the Helmholtz type could be used in order to obtain a homogeneous field better than +3 dB or to extend the volume of testable EUT.

Performance Criteria according to EN 61000-6-2: 2001 EMC - Generic standards - Immunity for industrial environments

Performance Criterion A

The apparatus shall continue to operate as intended. No degradation of performance or loss of function is allowed below a performance level specified by the manufacturer, when the apparatus is used as intended. In some cases the performance level may be replaced by a permissible loss of performance. If the minimum performance level or the permissible performance loss is not specified by the manufacturer then either of these may be derived from the product description and documentation, and what the user may reasonably expect from the apparatus if used as intended.

This criterion is to be used when the apparatus is stressed with an electromagnetic phenomenon of a continuous nature such as electromagnetic fields, magnetic fields, etc.

Performance Criterion B

The apparatus shall continue to operate as intended after the test. No degradation of performance or loss of function is allowed below a performance level specified by the manufacturer, when the apparatus is used as intended. In some cases the performance level may be replaced by a permissible loss of performance. During the test, degradation of performance is however allowed. If the minimum performance level or the permissible performance loss is not specified by the manufacturer then either of these may be derived from the product description and documentation, and what the user may reasonably expect from the apparatus if used as intended.

This criterion is to be used when the apparatus is stressed with an electromagnetic phenomenon of a transient nature such as electrostatic discharges, fast transients, and power supply voltage dips less than 10 ms in duration, etc.

Performance Criterion C

Temporary loss of function is allowed, provided the loss of function is self-recoverable, or can be restored by the operation of the controls. In cases where a manufacturer's specification specifically requires external protection devices or measures which are clearly specified in the users' manual, the test requirements of this standard may be applied with the external protection devices or measures in place.

This criterion is to be used when the apparatus is stressed with short supply voltage interruptions (in excess of 100 ms).

The specification of performance criteria in a generic standard is necessarily vague, given the diversity of types of apparatus which is within the scope.

7. Referenced Regulations

(see section "Reference Standards" for identical national standards)

Regulation	Comment
EN 55022: 2006 + A1: 2007	Limits & methods of measurement of radio disturbance characteristics of information technology equipment
EN 61000-3-2: 2000 + A2: 2005	Electromagnetic compatibility (EMC) Part 3: Limits Section 2: Limits for harmonic current emissions (Equipment input current less than or equal to 16 A per phase) PowerFactorCorrector
EN 61000-3-3: 1995 + A1: 2001 + A2: 2005	Electromagnetic compatibility (EMC) Part 3: Limits Section 3: Limits for voltage fluctuation and flicker for equipment with rated current ≤ 16 A PowerFactorCorrector
EN 61000-4-2: 1995 + A1: 1998 + A2: 2001	Electromagnetic compatibility (EMC) Part 4: Testing and measuring techniques Section 2: Electrostatic discharge immunity test
EN 61000-4-4: 2005	Electromagnetic compatibility (EMC) Part 4: Testing and measuring techniques Section 4: Electrical fast transients/Burst immunity test
EN 61000-4-5: 2006	Electromagnetic compatibility (EMC) Part 4: Testing and measuring techniques Section 5: Surge immunity test
EN 61000-4-6: 1996 + A1: 2001	Electromagnetic compatibility (EMC) Part 4: Testing and measuring techniques Section 6: Immunity to conducted disturbances induced by radio frequency fields
EN 61000-4-8: 1993 + A1: 2001	Electromagnetic compatibility (EMC) Part 4: Testing and measuring techniques Section 8: Power frequency magnetic field immunity test
EN 61000-4-11: 2004	Electromagnetic compatibility (EMC) Part 4: Testing and measuring techniques Section 11: Voltage dips, short interruptions and voltage variations immunity tests
Special standard	

8. List of Test Equipment

8.1 Radio Interference Emission Testing

	Type	Model	Equipment No.	Manufacturer
✓	EMI test receiver	ESMI	PM-EM-3158-1	Rohde & Schwarz
✓	LISN	ESH3-Z5	PM-EM-3142-1	Rohde & Schwarz
	LISN	ESH3-Z5	PM-EM-7561-1	Rohde & Schwarz
	LISN	ESH3-Z6	PM-EM-3136-1	Rohde & Schwarz
	LISN	ESH3-Z6	PM-EM-3137-1	Rohde & Schwarz
	LISN	ENV4200	PM-EM-7562-1	Rohde & Schwarz
✓	Pulse limiter	ESH3-Z2	PM-EM-3180-1	Rohde & Schwarz
	Pulse limiter	ESH3-Z2	PM-EM-7563-1	Rohde & Schwarz
✓	Current clamp	ESH2-Z1	PM-EM-3140-1	Rohde & Schwarz
	Current clamp	ESV-Z1	PM-EM-3140-1	Rohde & Schwarz
	Current clamp	F-61	PM-EM-7554-1	FCC
	Current clamp	F-65-A	PM-EM-8543-1	FCC
	Current clamp	F-36-4	PM-EM-6173-1	FCC
	Current clamp	F-2000	PM-EM-6171-1	FCC
✓	RF relays matrix	PSU	PM-EM-6101-1	Rohde & Schwarz
✓	HF room 10 kHz to 18 GHz	Shielded room	PM-EM-6172-1	Siemens Matsushita
	Drive quali. comp.	-----	PM-EM-8500-1	Kontron Elektronik

(check mark in 1st column) = tested

8.2 Immunity Testing

	Type	Model	Equipment No.	Manufacturer
✓	Hybrid generator	NSG 650	PM-EM-3148-1	Schaffner
✓	Coupling/decoupling network for NSG 650	CDN 110	PM-EM-3149-1	Schaffner
✓	Coupling network for NSG 650 & CDN110	INA 202	PM-EM-4134-1	Schaffner
✓	Coupling network for NSG 650 & CDN110	INA 204	PM-EM-4136-1	Schaffner
✓	Coupling network for NSG 650 & CDN110	INA 206	PM-EM-4138-1	Schaffner
	Coupling/decoupling network for NSG 650 (data line)	CDN 115	PM-EM-4140-1	Schaffner
	40 Ω resistor for NSG 650 & CDN115	INA 110-40	PM-EM-7519-1	Schaffner
✓	HF room 10 kHz to 18 GHz	Shielded room	PM-EM-6172-1	Siemens Matsushita
✓	ESD generator	NSG 435	PM-EM-9014	Schaffner
✓	19" Rack EN61000- 3-2/3-3/4-8/4-11/4-13	PHE5000/ PAS	PM-EM-6519-1	Spitzenberger & SPIES
✓	Burst generator	NSG 2025	PM-EM-6162-1	Schaffner
✓	Capacitive coupling clamp	CDN 8014	PM-EM-3147-1	Schaffner
	Oscilloscope	HM203-7	PM-EM-3184-1	Hameg
	Digital multimeter	Fluke 83	PM-EM-7560-1	FLUKE
	Coupling/decoupling network, coaxial lines	FCC-801-C1-N-50	PM-EM-7527-1	FCC
	Coupling/decoupling network, coaxial lines	FCC-801-C1-N-50	PM-EM-7529-1	FCC
	Coupling/decoupling network, single pole	FCC-801-M1-25	PM-EM-7531-1	FCC

(check mark in 1st column) = tested

List of Test Equipment: Immunity Testing (continued)

	Type	Model	Equipment No.	Manufacturer
✓	Coupling/decoupling network, single pole	FCC-801-M2-25	PM-EM-7543-1	FCC
✓	Coupling/decoupling network, single pole	FCC-801-M3-25	PM-EM-7544-1	FCC
	EM clamp	F-203I-32mm	PM-EM-7534-1	FCC
	Decoupling clamp for EM clamp	F-203I-DCN-32mm	PM-EM-7535-1	FCC
✓	Current clamp 100 kHz to 230 MHz	F-120-9A	PM-EM-7546-1	FCC
✓	19" rack test system EN 61000-4-6	61000-4-6	PM-EM-7542-1	NeWeTec
	Current clamp	F-61	PM-EM-7554-1	FCC
	Current clamp	F-65A	PM-EM-7554-1	FCC
	Drive quali. comp.	-----	PM-EM-8500-1	Kontron Elektronik
✓	Helmholtz coil set	KEC	PM-EM-7558-1	KEC

(check mark in 1st column) = tested

9. Photographs of EUT and Test Setup

9.1 Test Setup EN 55022, conducted & radiated emissions

Limits & methods of measurement of radio disturbance characteristics of information technology equipment

Radiated and Conducted Emissions Test (test distance 1m)

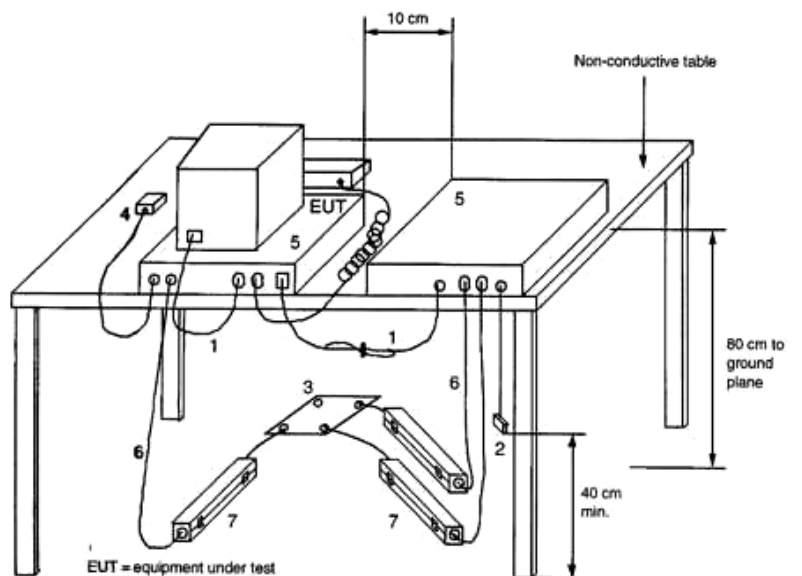

9.2 Test Setup EN 55022, conducted emissions

Conducted Emissions at the telecommunication ports

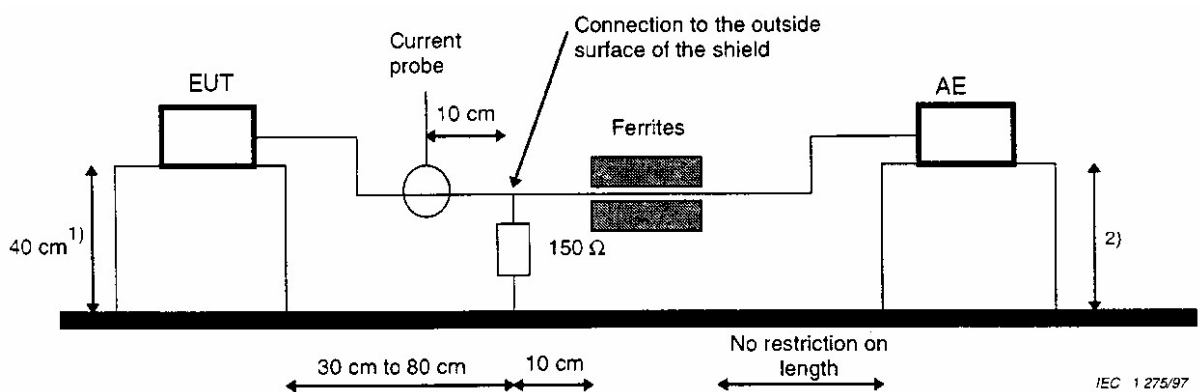

AE = Associated equipment
 EUT = Equipment under test

- 1) Distance to the reference groundplane (vertical or horizontal).
- 2) Distance to the reference groundplane is not critical.

Figure C.2

9.3 Test Setup EN 61000-4-2

Electrostatic discharge immunity test

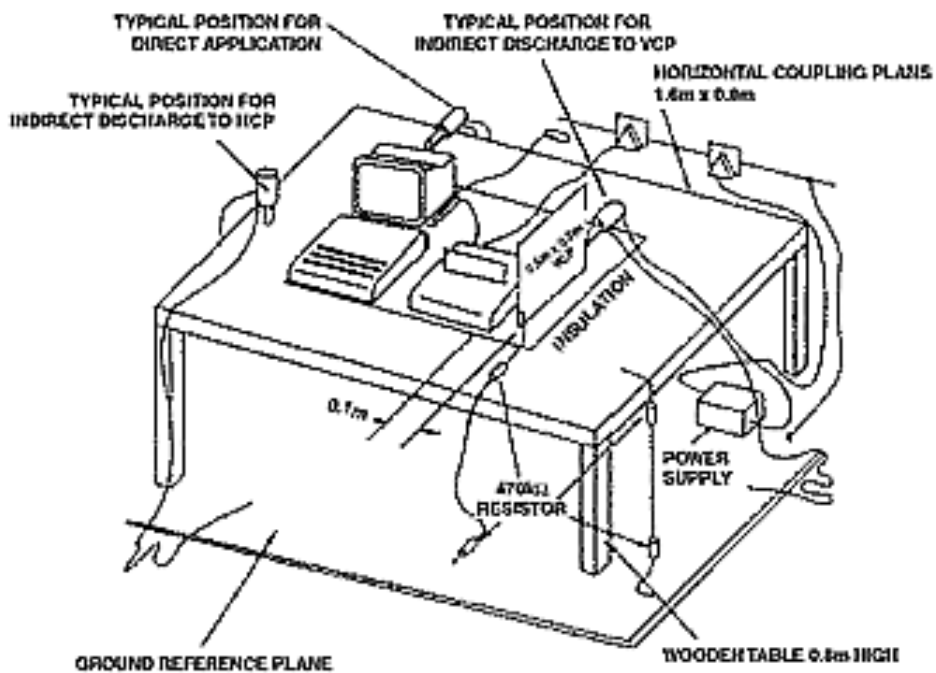

Electrostatic discharge immunity test – pulses location

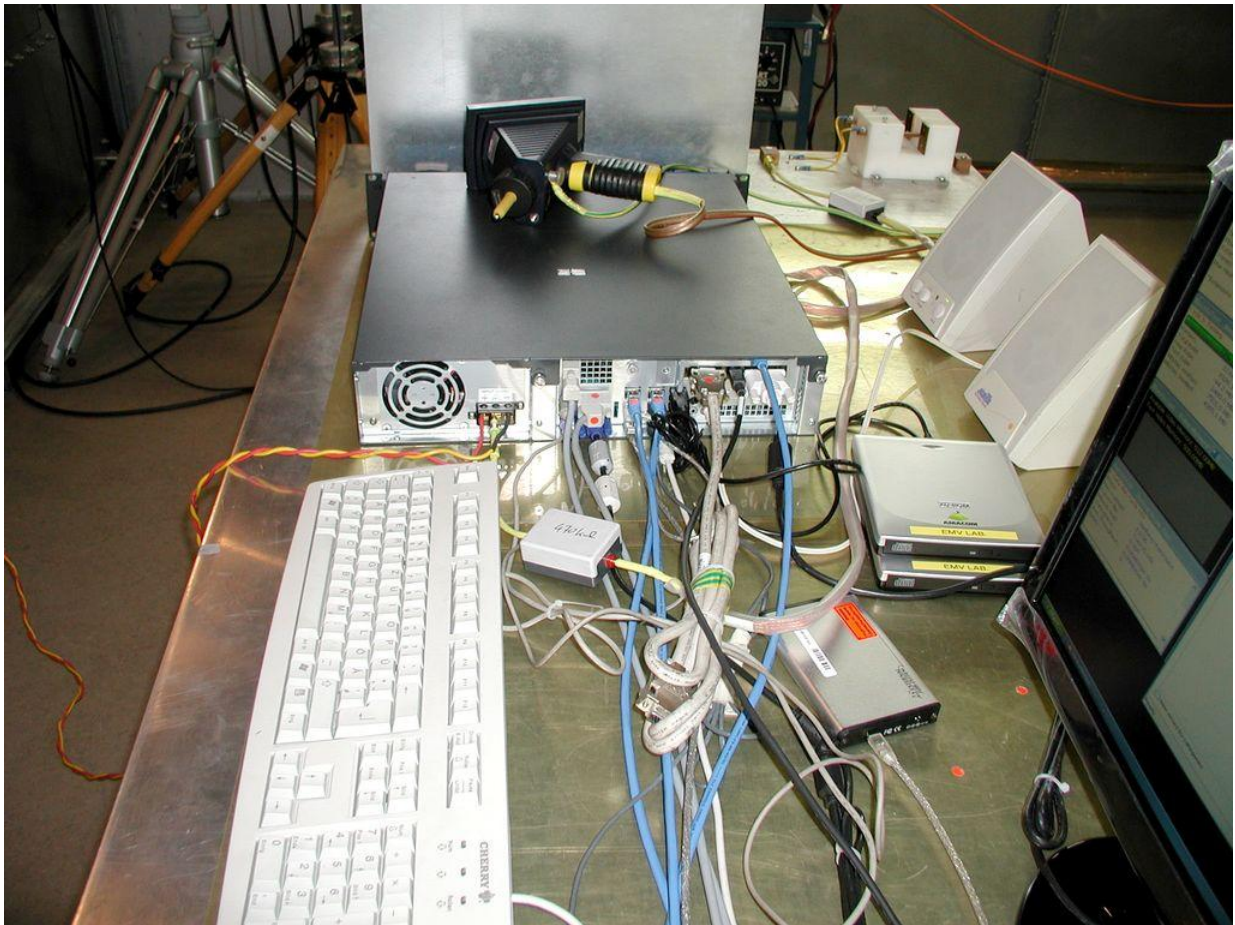

9.4 Test Setup EN 61000-4-4

Burst immunity test

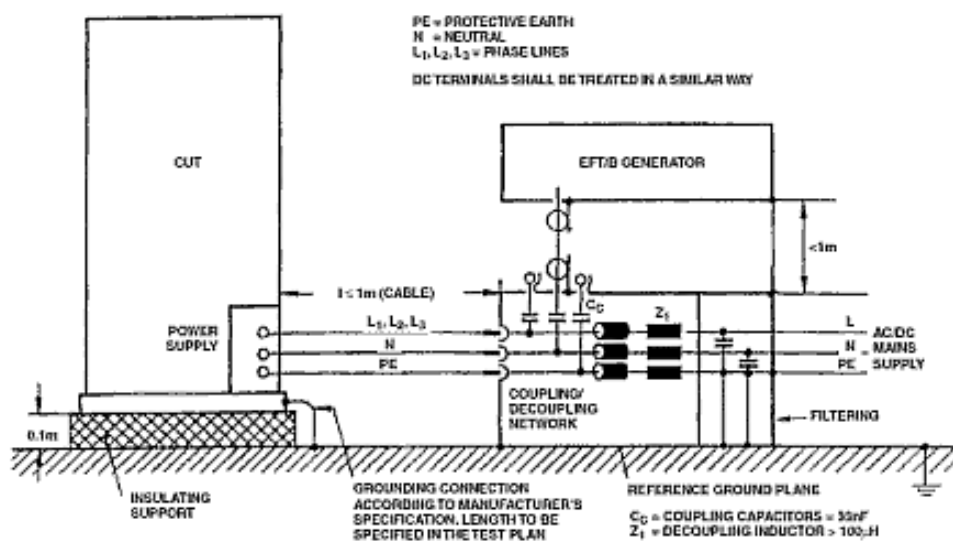

9.5 Test Setup EN 61000-4-5

Surge immunity test

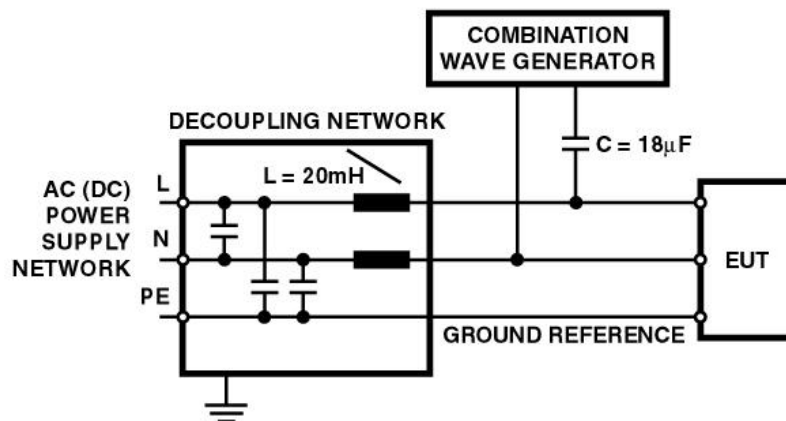
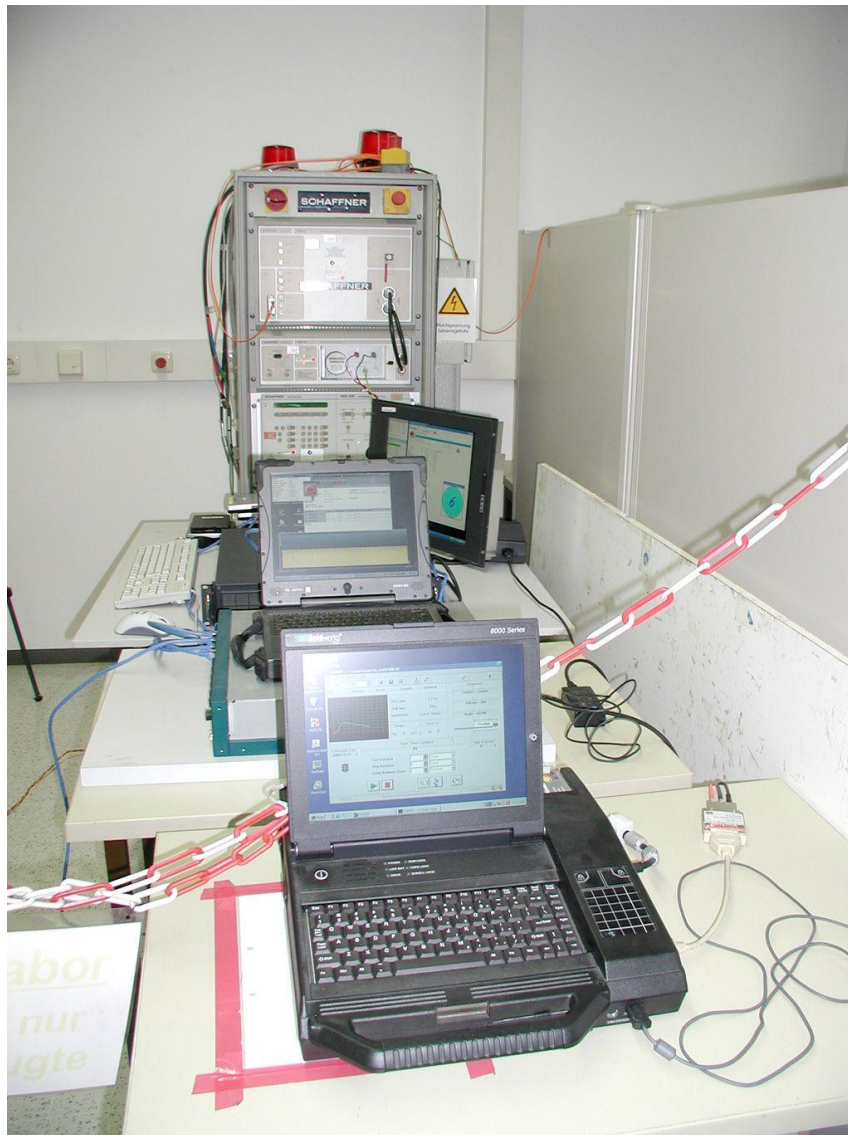

TEST SETUP FOR CAPACITIVE COUPLING ON AC/DC LINES; LINE TO LINE COUPLING ACCORDING TO 7.2

9.6 Test Setup EN 61000-4-6

Immunity to conducted disturbances induced by radio frequency fields test

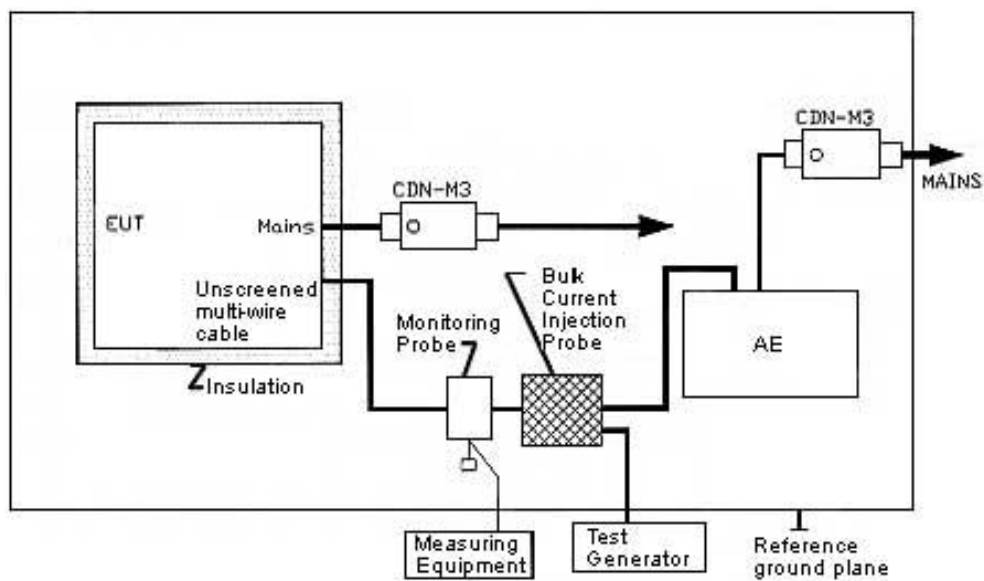

9.7 Test Setup EN 61000-4-8

EMC Laboratory- Kontron Embedded Computers GmbH- Helmholtz coil



9.8 Test Setup EN 61000-3-2; 3-3; - 4-11

Voltage dips, short interruption, and voltage variations immunity



10. Test Report (Forms)

10.1 Test Report EN 55022

Conducted and radiated emissions

10.1.1 PSU1 - FSP400-60PFB, FSP Group Inc.

Conducted Emissions – Class B

Radiated emissions – Class A

**Conducted Emission Test 150 kHz - 30 MHz
acc. to EN 55022 Class B / CISPR 22**

<p>Model: KISS 2U 45-y</p> <p>Serial no.: 001</p> <p>Applicant: Schiege K.</p> <p>Test site: Shielded room PM-EM-6172-1</p> <p>Tested on: Linecord Phase L1</p> <p>Date of test: 03/10/2010</p> <p>Test performed: automatically</p>	<p>Comment: KISS 2U 45-y, 2-A0ED-20xx</p> <p>PSU: FSP400-60PFB AC</p> <p>Accessories: PS/2 Keyboard and PS/2 Mouse, 23" DVI LCD Display and Headset</p> <p>Connected data cables: VGA, COM1-2, LAN1-3 and USB1-8 (rear)</p> <p>- BitPro v6.0 test SW: 2D Graphic H-Pattern test</p> <p>- Display OFF</p> <p>- left side (270°)</p>
<p>Detector: Peak / Final Results: QP</p>	<p>Final results: 20 dB Margin 50 Subranges</p>

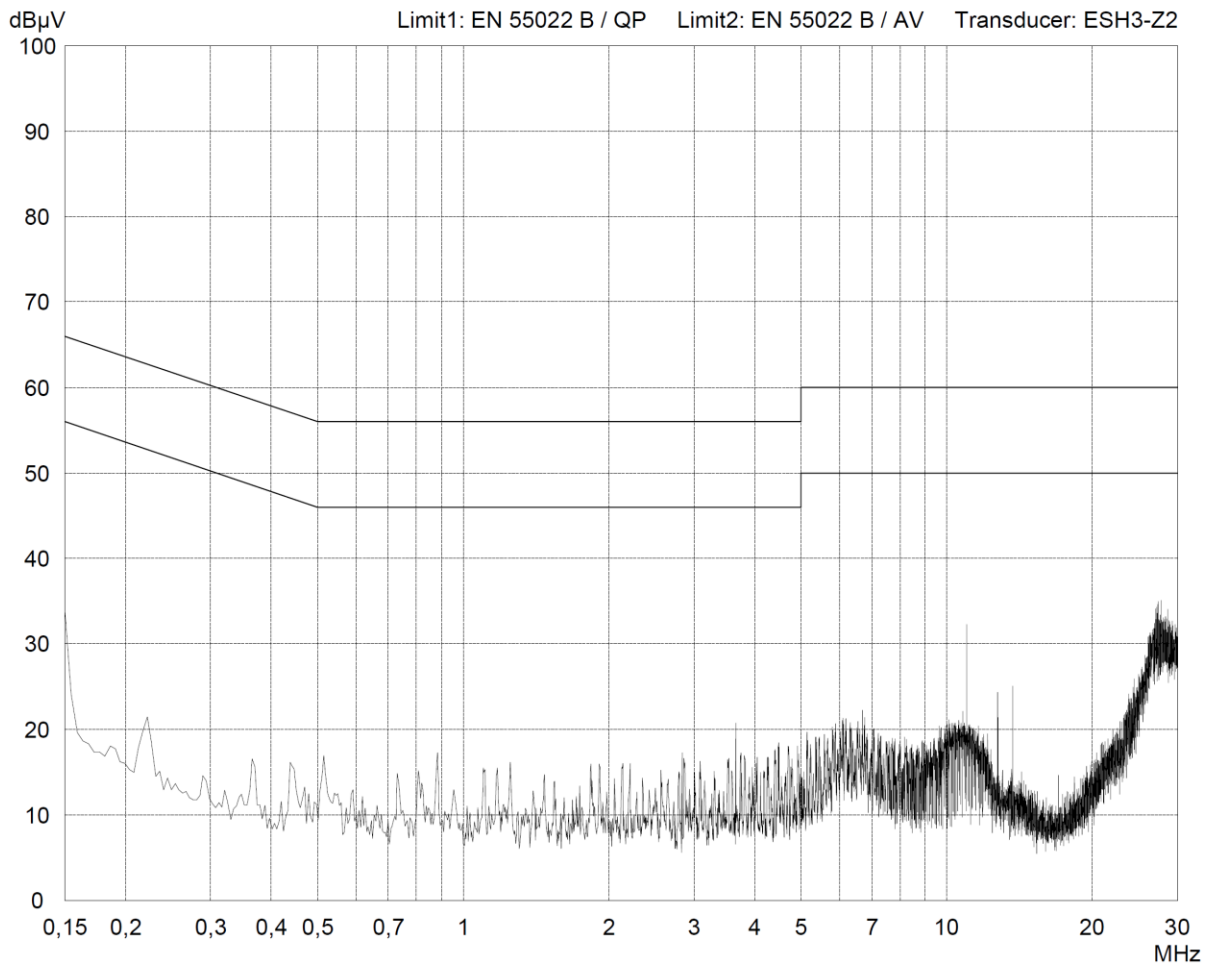

**Conducted Emission Test 150 kHz - 30 MHz
acc. to EN 55022 Class B / CISPR 22**

<p>Model: KISS 2U 45-y</p> <p>Serial no.: 001</p> <p>Applicant: Schiege K.</p> <p>Test site: Shielded room PM-EM-6172-1</p> <p>Tested on: Linecord Phase N</p> <p>Date of test: 03/10/2010</p> <p>Test performed: automatically</p>	<p>Comment: KISS 2U 45-y, 2-A0ED-20xx</p> <p>PSU: FSP400-60PFB AC</p> <p>Accessories: PS/2 Keyboard and PS/2 Mouse, 23" DVI LCD Display and Headset</p> <p>Connected data cables: VGA, COM1-2, LAN1-3 and USB1-8 (rear)</p> <p>- BitPro v6.0 test SW: 2D Graphic H-Pattern test</p> <p>- Display OFF</p> <p>- left side (270°)</p>
<p>Detector: Peak / Final Results: QP</p>	<p>Final results: 20 dB Margin 50 Subranges</p>

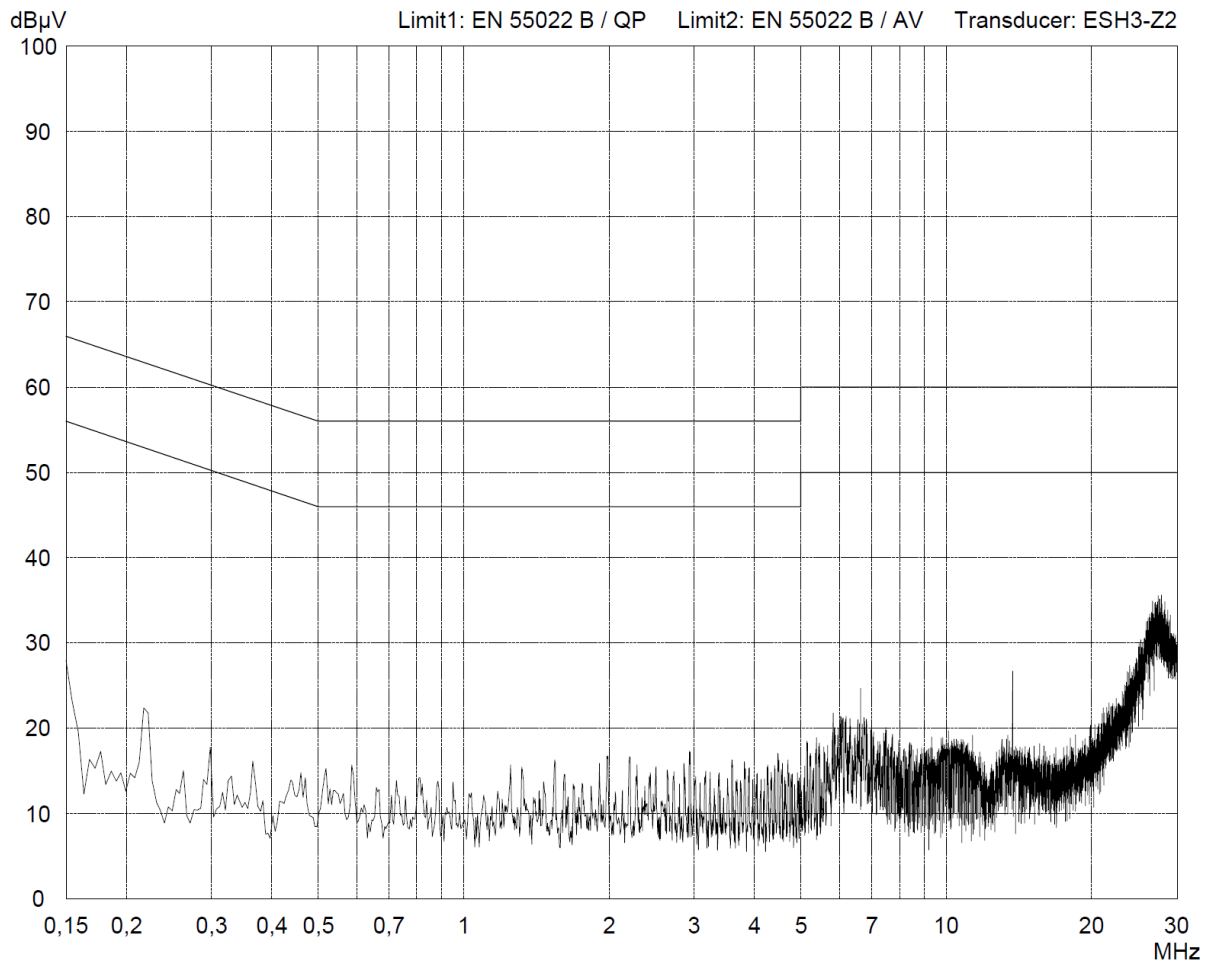

**Conducted Emission Test 150 kHz - 30 MHz
acc. to EN 55022 Class B / CISPR 22**

<p>Model: KISS 2U 45-y</p> <p>Serial no.: 001</p> <p>Applicant: Schiege K.</p> <p>Test site: Shielded room PM-EM-6172-1</p> <p>Tested on: Signal and control lines LAN1</p> <p>Date of test: 01/20/2010</p> <p>Test performed: automatically</p>	<p>Comment: FSP400-60PFB</p> <p>Accessories: PS/2 Keyboard and PS/2 Mouse, 23" DVI LCD Display</p> <p>Connected data cable: LAN1 (MB)</p> <p>- BitPro v6.0 test SW: LAN port 50% loaded</p> <p>- Display ON</p>
<p>Operator: P. Vesely, Novak H.</p> <p>File name:</p>	<p>Final results: 20 dB Margin 50 Subranges</p>
<p>Detector: Peak / Final Results: QP</p>	

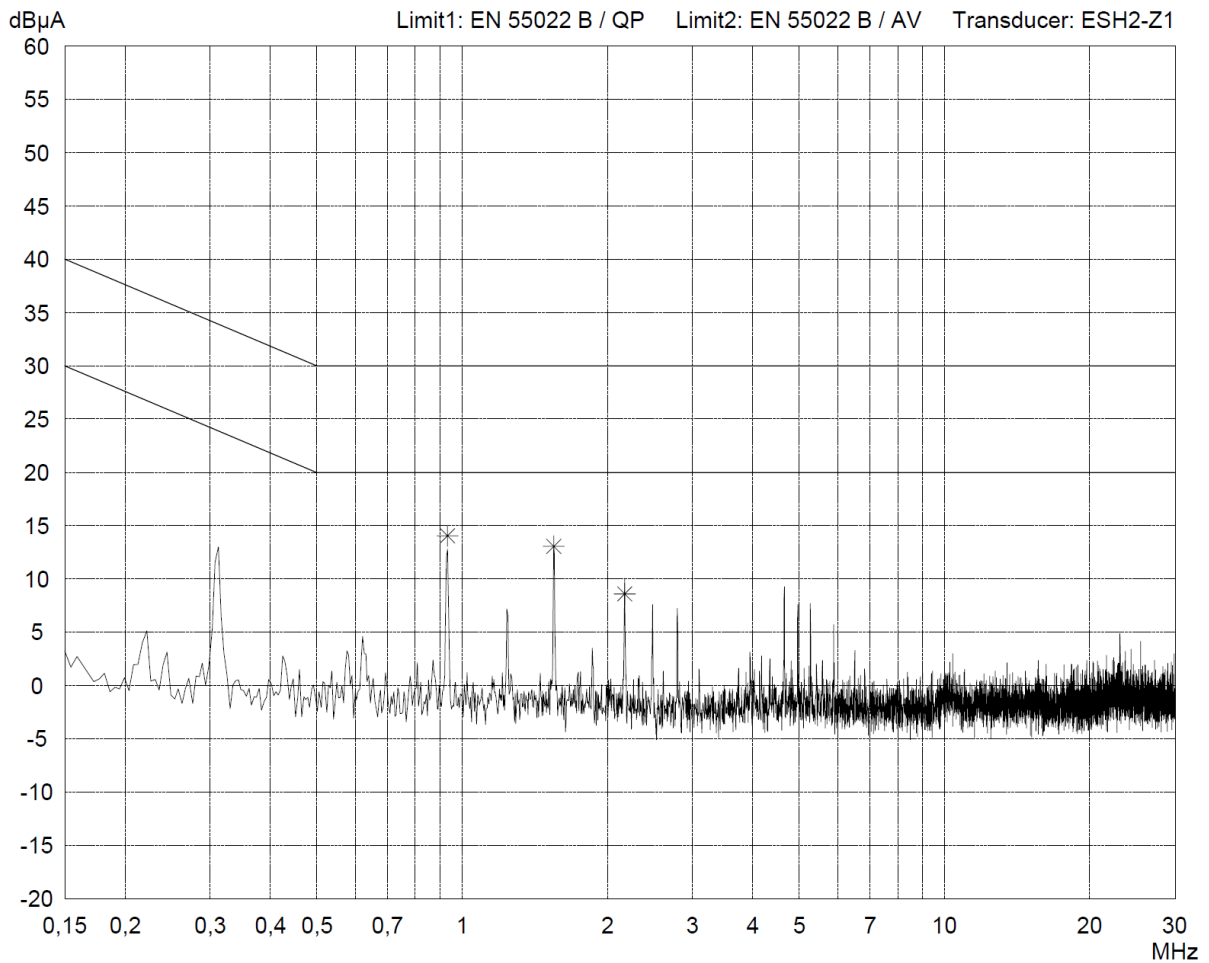

**Conducted Emission Test 150 kHz - 30 MHz
acc. to EN 55022 Class B / CISPR 22**

<p>Model: KISS 2U 45-y</p> <p>Serial no.: 001</p> <p>Applicant: Schiege K.</p> <p>Test site: Shielded room PM-EM-6172-1</p> <p>Tested on: Signal and control lines LAN2</p> <p>Date of test: 01/20/2010</p> <p>Test performed: automatically</p>	<p>Comment: FSP400-60PFB</p> <p>Accessories: PS/2 Keyboard and PS/2 Mouse, 23" DVI LCD Display</p> <p>Connected data cable: LAN2 (MB)</p> <p>- BitPro v6.0 test SW: LAN port 50% loaded</p> <p>- Display ON</p>
<p>Operator: P. Vesely, Novak H.</p> <p>File name:</p>	<p>Final results: 20 dB Margin 50 Subranges</p>
<p>Detector: Peak / Final Results: QP</p>	

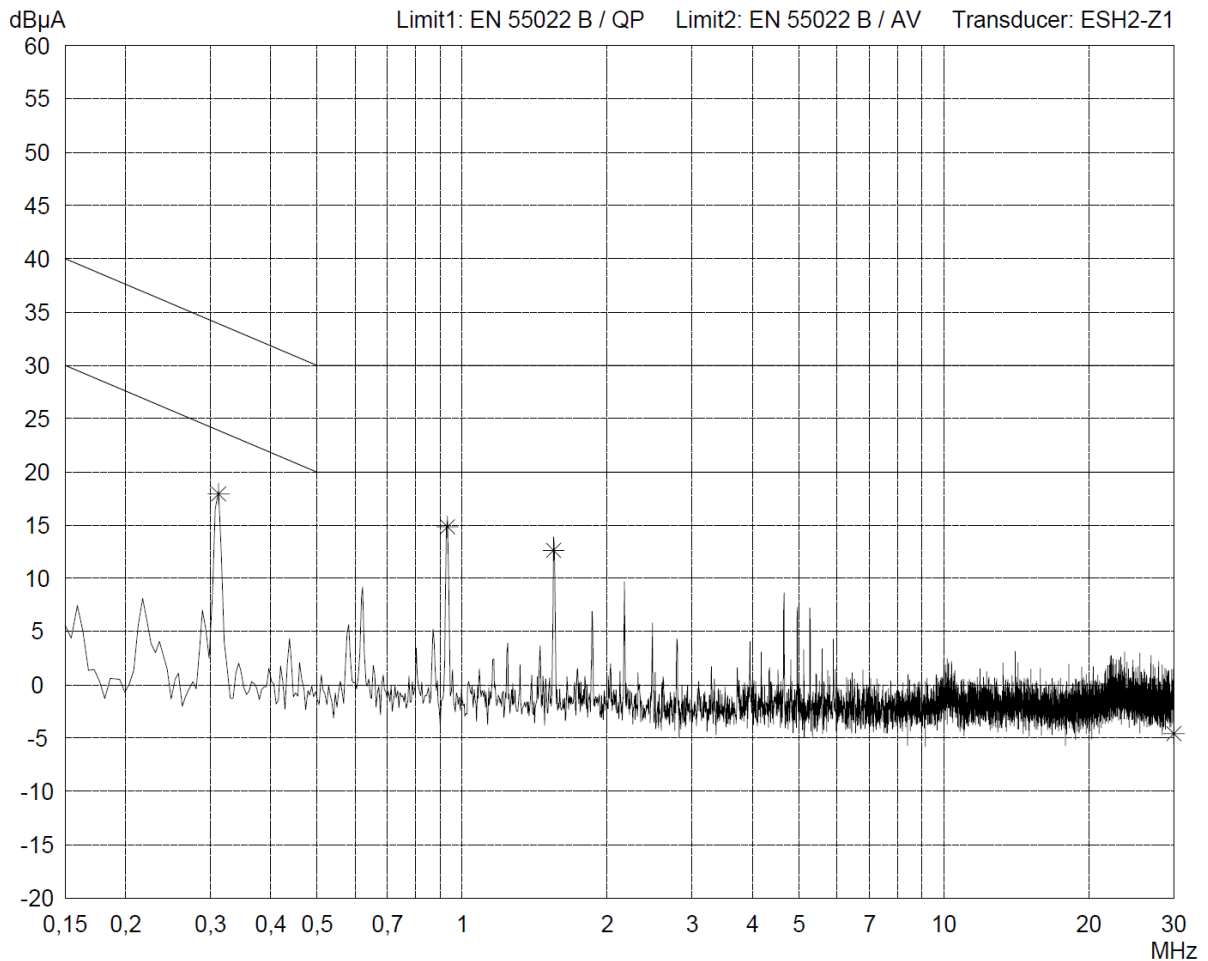

**Conducted Emission Test 150 kHz - 30 MHz
acc. to EN 55022 Class B / CISPR 22**

Model: KISS 2U 45-y	Comment: FSP400-60PFB Accessories: PS/2 Keyboard and PS/2 Mouse, 23" DVI LCD Display Connected data cable: LAN3 (PCI) - BitPro v6.0 test SW: LAN port 50% loaded - Display ON	
Serial no.: 001		
Applicant: Schiege K.		
Test site: Shielded room PM-EM-6172-1		
Tested on: Signal and control lines LAN3		
Date of test: 01/20/2010		Operator: P. Vesely, Novak H.
Test performed: automatically		File name:
Detector: Peak / Final Results: QP	Final results: 20 dB Margin 50 Subranges	

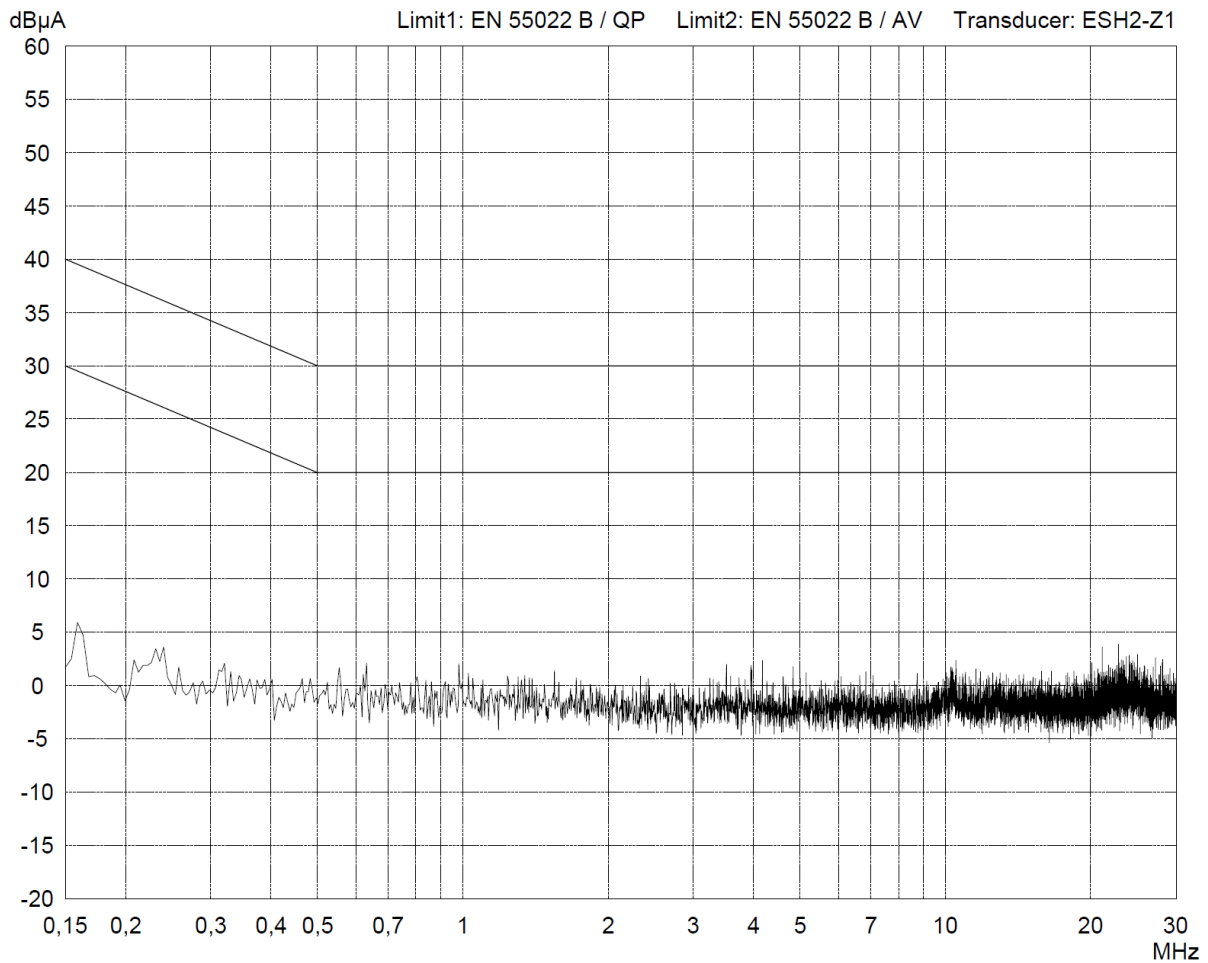

**Radiated Emission Test 30 MHz - 200 MHz
acc. to KE_30MHz-200MHz**

<p>Model: KISS 2U 45-y</p> <p>Serial no.: 001</p> <p>Applicant: Schiege K.</p> <p>Test site: Shielded room PM-EM-6172-1</p> <p>Tested on: Distance 1m Horizontal Polarization</p> <p>Date of test: 03/10/2010</p> <p>Test performed: automatically</p>	<p>Comment: KISS 2U 45-y, 2-A0ED-20xx</p> <p>PSU: FSP400-60PFB AC</p> <p>Accessories: PS/2 Keyboard and PS/2 Mouse, 23" DVI LCD Display and Headset</p> <p>Connected data cables: VGA, COM1-2, LAN1-3 and USB1-8 (rear)</p> <p>- BitPro v6.0 test SW: 2D Graphic H-Pattern test</p> <p>- Display OFF</p> <p>- front side (0°)</p>
<p>Detector: Peak / Final Results: QP</p>	<p>Final results: 20 dB Margin 50 Subranges</p>

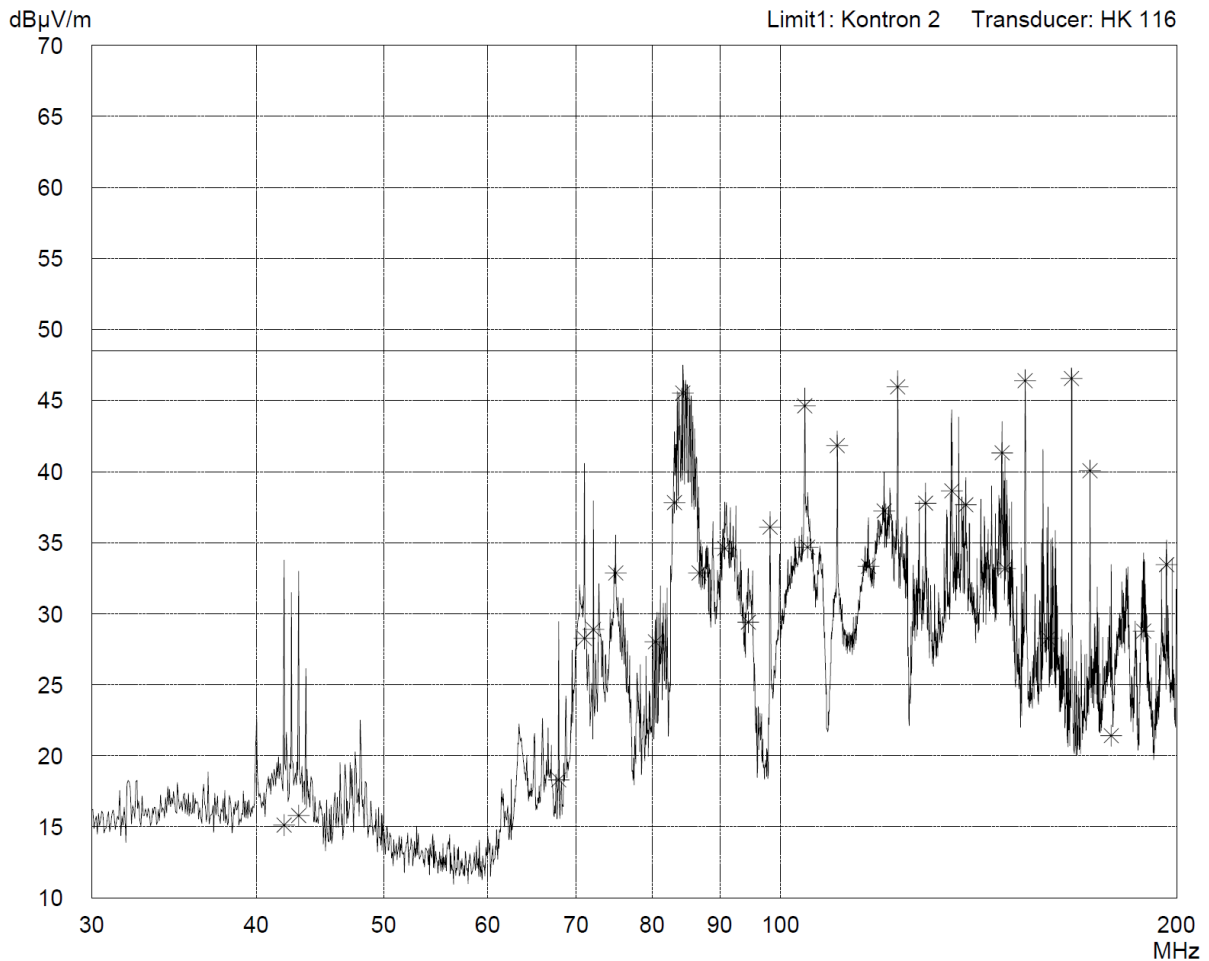

Radiated Emission Test 30 MHz - 200 MHz
acc. to KE_30MHz-200MHz

<p>Model: KISS 2U 45-y</p> <p>Serial no.: 001</p> <p>Applicant: Schiege K.</p> <p>Test site: Shielded room PM-EM-6172-1</p> <p>Tested on: Distance 1m Vertical Polarization</p> <p>Date of test: 03/10/2010</p> <p>Test performed: automatically</p>	<p>Comment: KISS 2U 45-y, 2-A0ED-20xx</p> <p>PSU: FSP400-60PFB AC</p> <p>Accessories: PS/2 Keyboard and PS/2 Mouse, 23" DVI LCD Display and Headset</p> <p>Connected data cables: VGA, COM1-2, LAN1-3 and USB1-8 (rear)</p> <p>- BitPro v6.0 test SW: 2D Graphic H-Pattern test</p> <p>- Display OFF</p> <p>- front side (0°)</p>
<p>Detector: Peak / Final Results: QP</p>	<p>Final results: 20 dB Margin 50 Subranges</p>

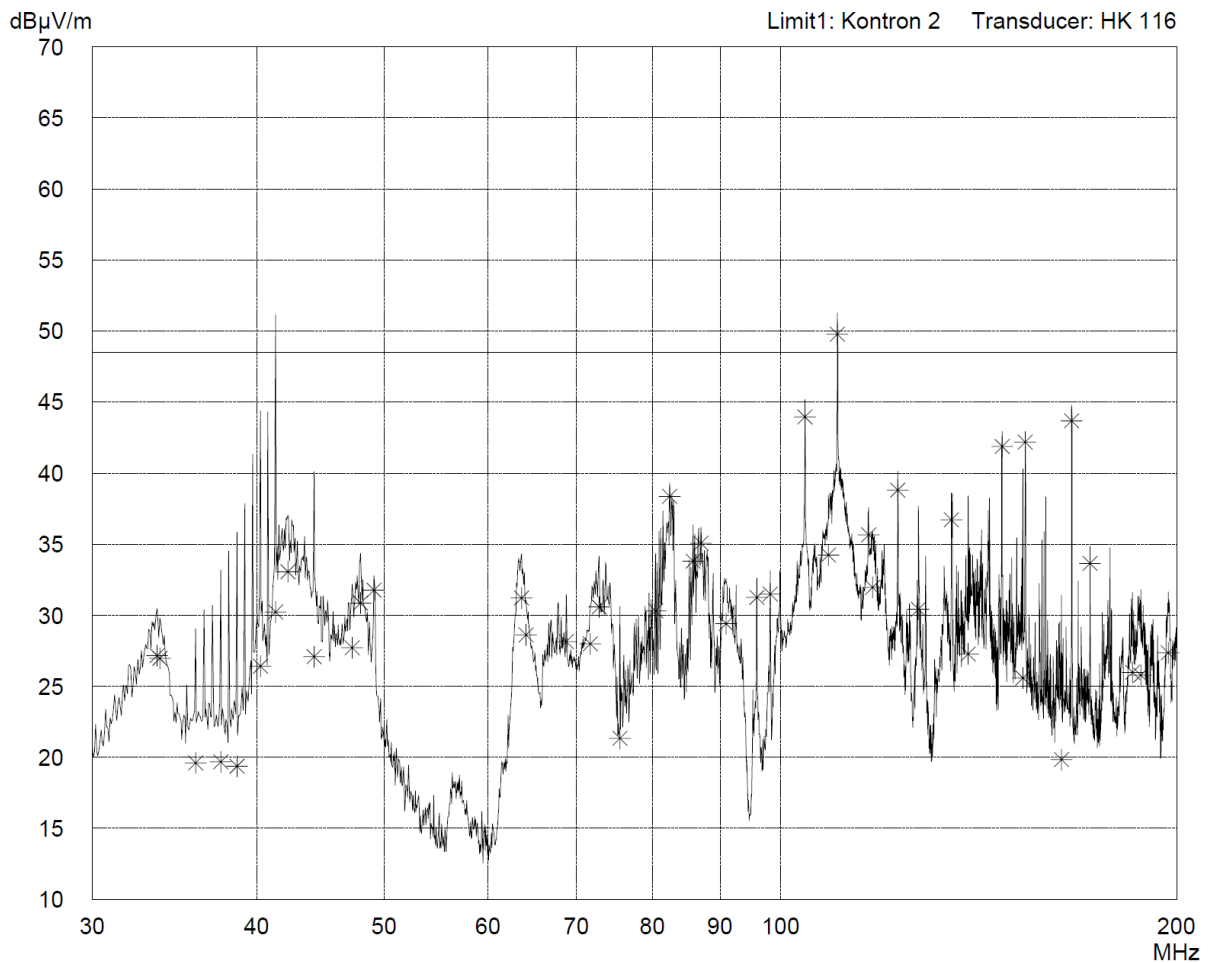

Radiated Emission Test 200 MHz - 1 GHz
acc. to KE_200MHz-2GHz

Model: KISS 2U 45-y	Comment: KISS 2U 45-y, 2-A0ED-20xx PSU: FSP400-60PFB AC Accessories: PS/2 Keyboard and PS/2 Mouse, 23" DVI LCD Display and Headset Connected data cables: VGA, COM1-2, LAN1-3 and USB1-8 (rear) - BitPro v6.0 test SW: 2D Graphic H-Pattern test - Display OFF - front side (0°)	
Serial no.: 001		
Applicant: Schiege K.		
Test site: Shielded room PM-EM-6172-1		
Tested on: Distance 1m Circular Polarization		
Date of test: 03/10/2010		Operator: Vesely P.
Test performed: automatically		File name:
Detector: Peak / Final Results: QP	Final results: 20 dB Margin 50 Subranges	

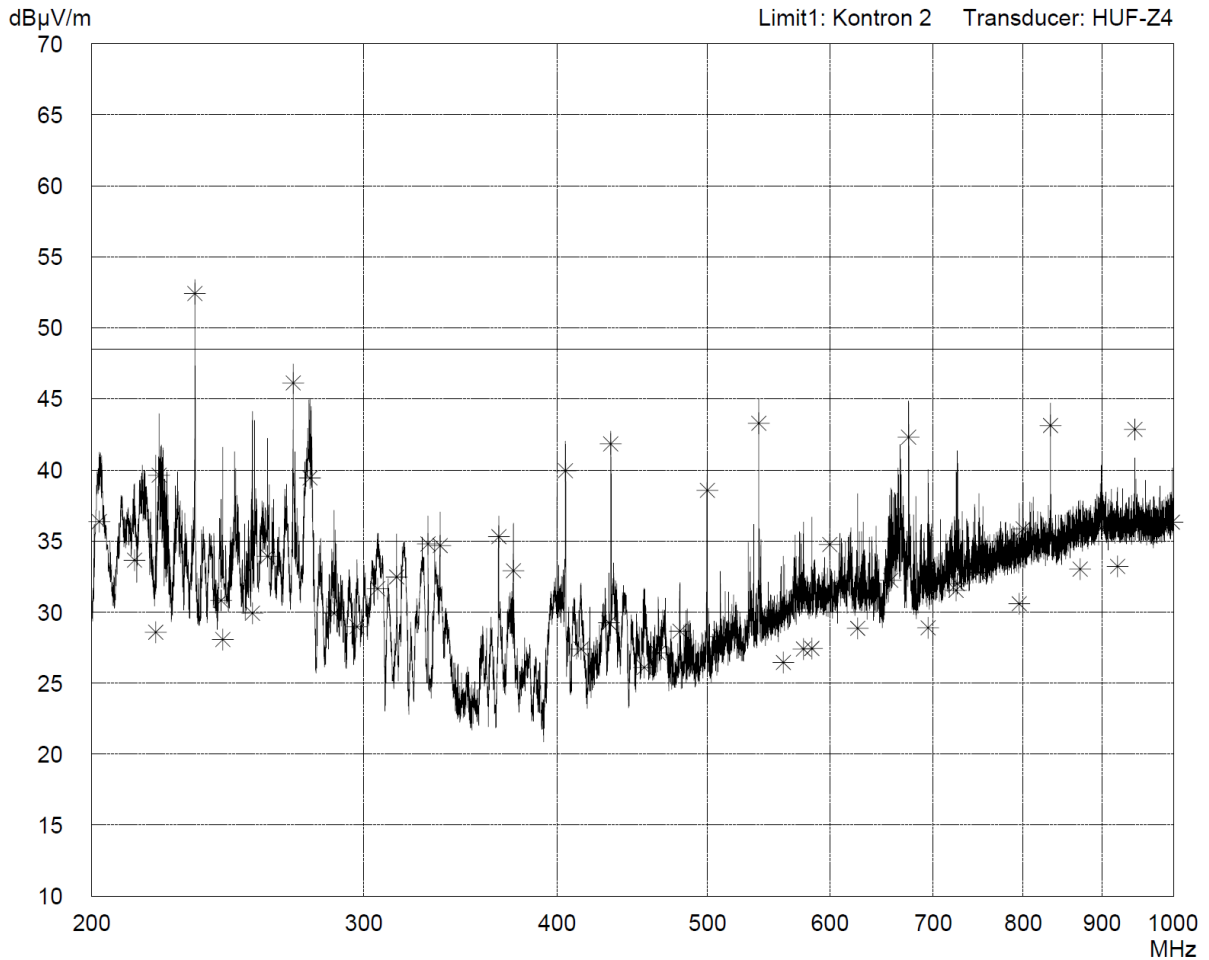

Radiated Emission Test 30 MHz - 200 MHz
acc. to KE_30MHz-200MHz

<p>Model: KISS 2U 45-y</p> <p>Serial no.: 001</p> <p>Applicant: Schiege K.</p> <p>Test site: Shielded room PM-EM-6172-1</p> <p>Tested on: Distance 1m Horizontal Polarization</p> <p>Date of test: 03/10/2010</p> <p>Operator: Vesely P.</p> <p>Test performed: automatically</p> <p>File name:</p>	<p>Comment: KISS 2U 45-y, 2-A0ED-20xx</p> <p>PSU: FSP400-60PFB AC</p> <p>Accessories: PS/2 Keyboard and PS/2 Mouse, 23" DVI LCD Display and Headset</p> <p>Connected data cables: VGA, COM1-2, LAN1-3 and USB1-8 (rear)</p> <p>- BitPro v6.0 test SW: 2D Graphic H-Pattern test</p> <p>- Display OFF</p> <p>- interface side (180°)</p>
<p>Detector: Peak / Final Results: QP</p>	<p>Final results: 20 dB Margin 50 Subranges</p>

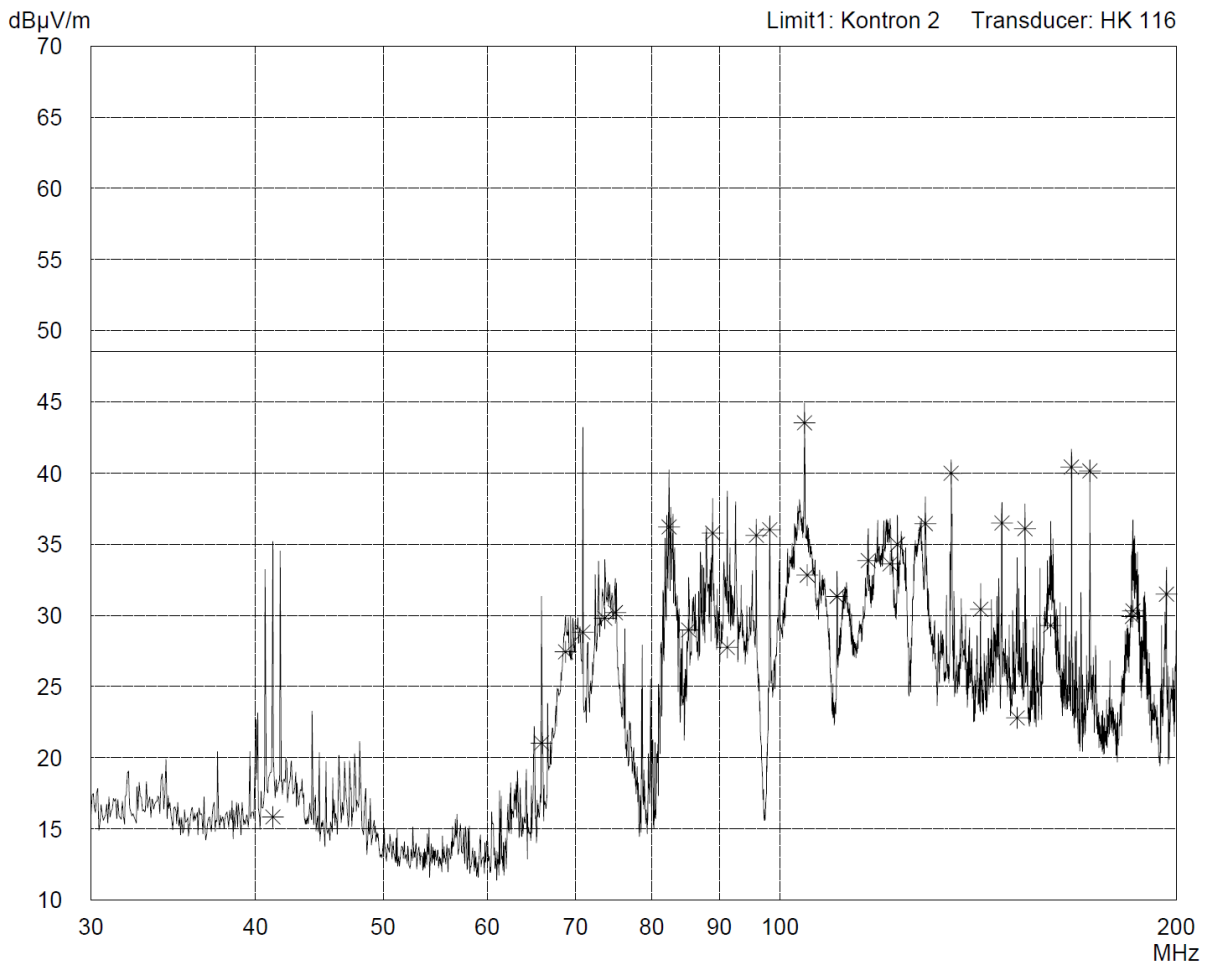

**Radiated Emission Test 30 MHz - 200 MHz
acc. to KE_30MHz-200MHz**

Model: KISS 2U 45-y	Comment: KISS 2U 45-y, 2-A0ED-20xx PSU: FSP400-60PFB AC Accessories: PS/2 Keyboard and PS/2 Mouse, 23" DVI LCD Display and Headset Connected data cables: VGA, COM1-2, LAN1-3 and USB1-8 (rear) - BitPro v6.0 test SW: 2D Graphic H-Pattern test - Display OFF - interface side (180°)	
Serial no.: 001		
Applicant: Schiege K.		
Test site: Shielded room PM-EM-6172-1		
Tested on: Distance 1m Vertical Polarization		
Date of test: 03/10/2010		Operator: Vesely P.
Test performed: automatically		File name:
Detector: Peak / Final Results: QP	Final results: 20 dB Margin 50 Subranges	

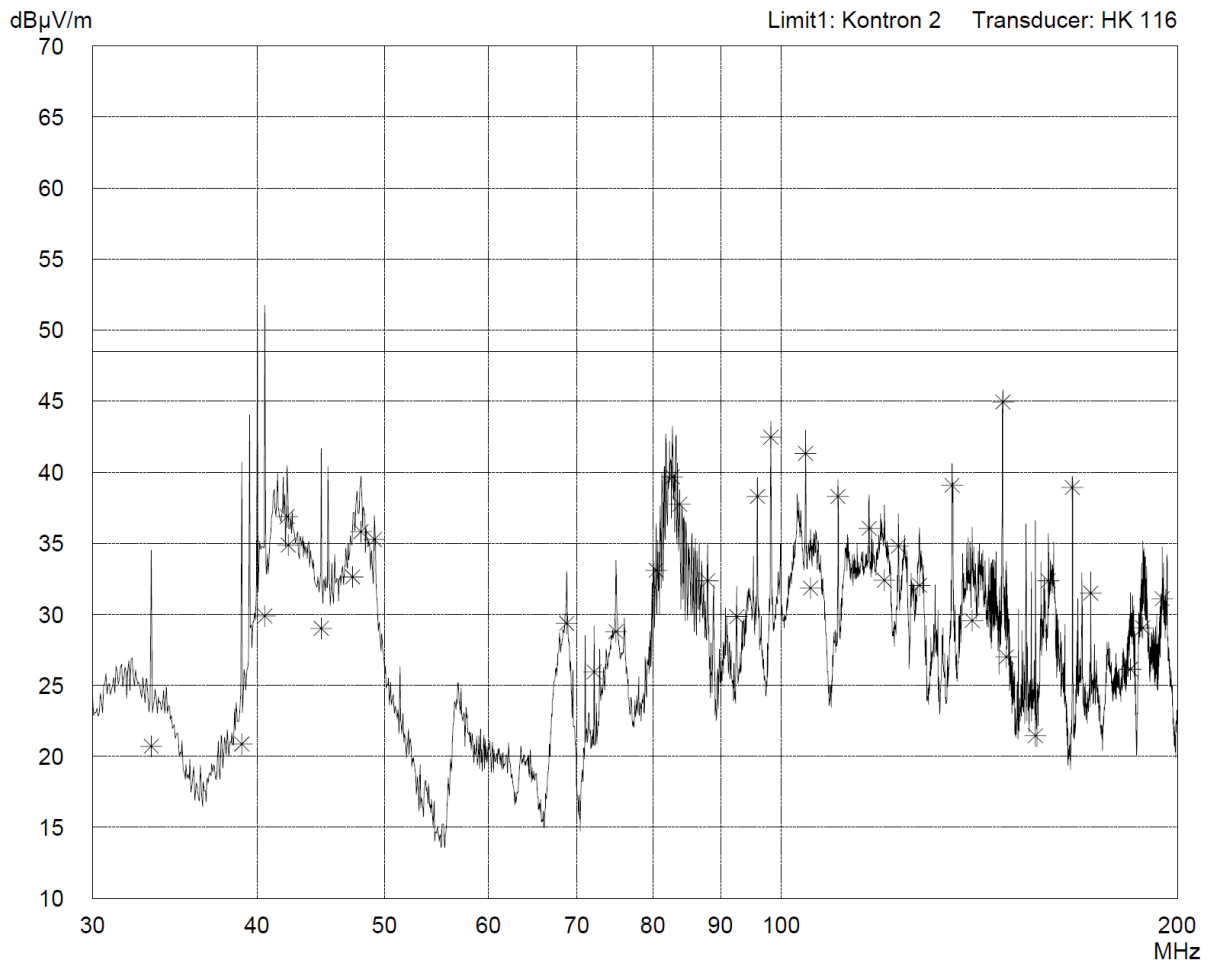

**Radiated Emission Test 200 MHz - 1 GHz
acc. to KE_200MHz-2GHz**

<p>Model: KISS 2U 45-y</p> <p>Serial no.: 001</p> <p>Applicant: Schiege K.</p> <p>Test site: Shielded room PM-EM-6172-1</p> <p>Tested on: Distance 1m Circular Polarization</p> <p>Date of test: 03/10/2010</p> <p>Test performed: automatically</p>	<p>Comment: KISS 2U 45-y, 2-A0ED-20xx</p> <p>PSU: FSP400-60PFB AC</p> <p>Accessories: PS/2 Keyboard and PS/2 Mouse, 23" DVI LCD Display and Headset</p> <p>Connected data cables: VGA, COM1-2, LAN1-3 and USB1-8 (rear)</p> <p>- BitPro v6.0 test SW: 2D Graphic H-Pattern test</p> <p>- Display OFF</p> <p>- interface side (180°)</p>
<p>Detector: Peak / Final Results: QP</p>	<p>Final results: 20 dB Margin 50 Subranges</p>

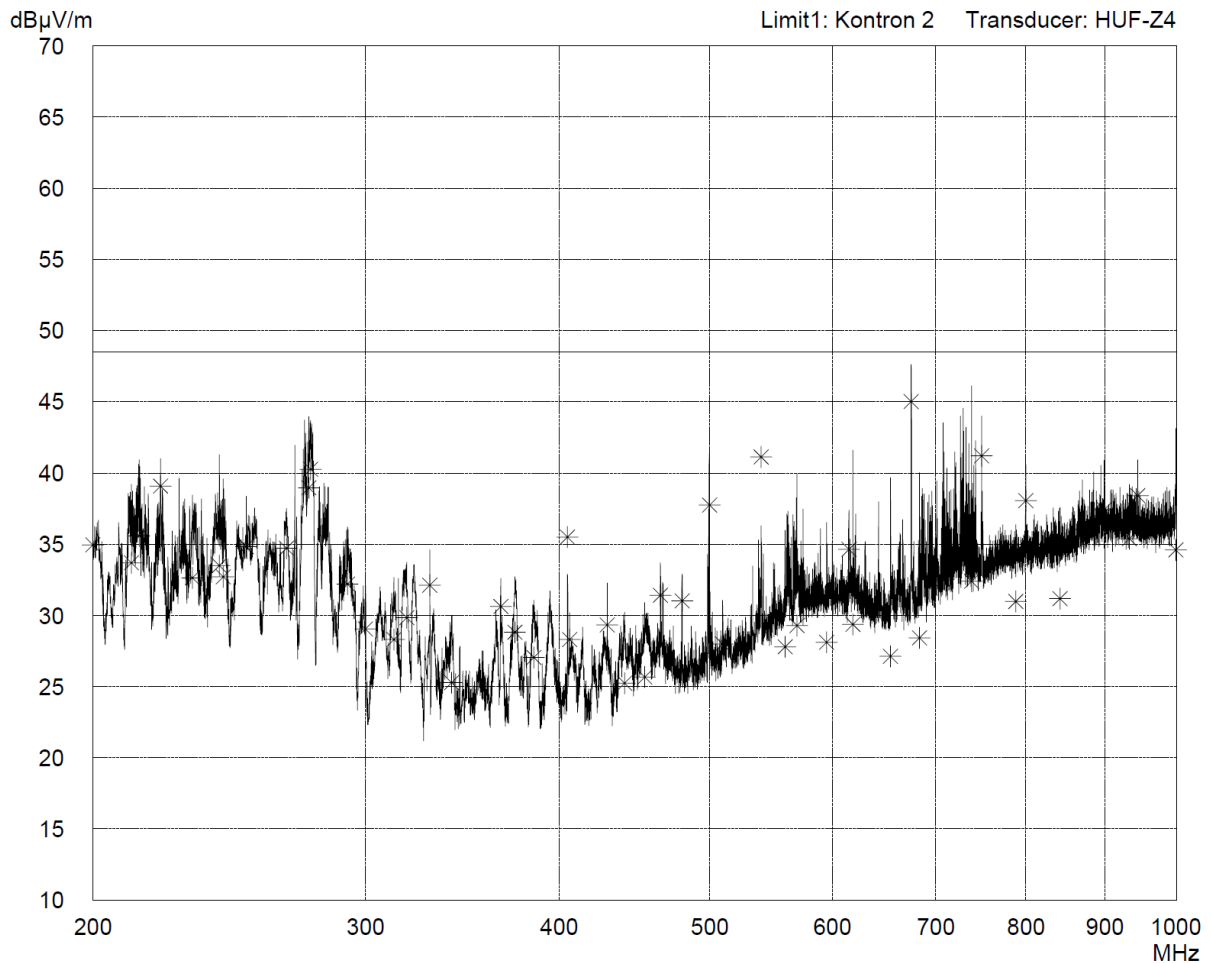

Radiated Emission Test 30 MHz - 200 MHz
acc. to KE_30MHz-200MHz

<p>Model: KISS 2U 45-y</p> <p>Serial no.: 001</p> <p>Applicant: Schiege K.</p> <p>Test site: Shielded room PM-EM-6172-1</p> <p>Tested on: Distance 1m Horizontal Polarization</p> <p>Date of test: 03/10/2010</p> <p>Test performed: automatically</p>	<p>Comment: KISS 2U 45-y, 2-A0ED-20xx</p> <p>PSU: FSP400-60PFB AC</p> <p>Accessories: PS/2 Keyboard and PS/2 Mouse, 23" DVI LCD Display and Headset</p> <p>Connected data cables: VGA, COM1-2, LAN1-3 and USB1-8 (rear)</p> <p>- BitPro v6.0 test SW: 2D Graphic H-Pattern test</p> <p>- Display OFF</p> <p>- left side (270°)</p>
<p>Detector: Peak / Final Results: QP</p>	<p>Final results: 20 dB Margin 50 Subranges</p>

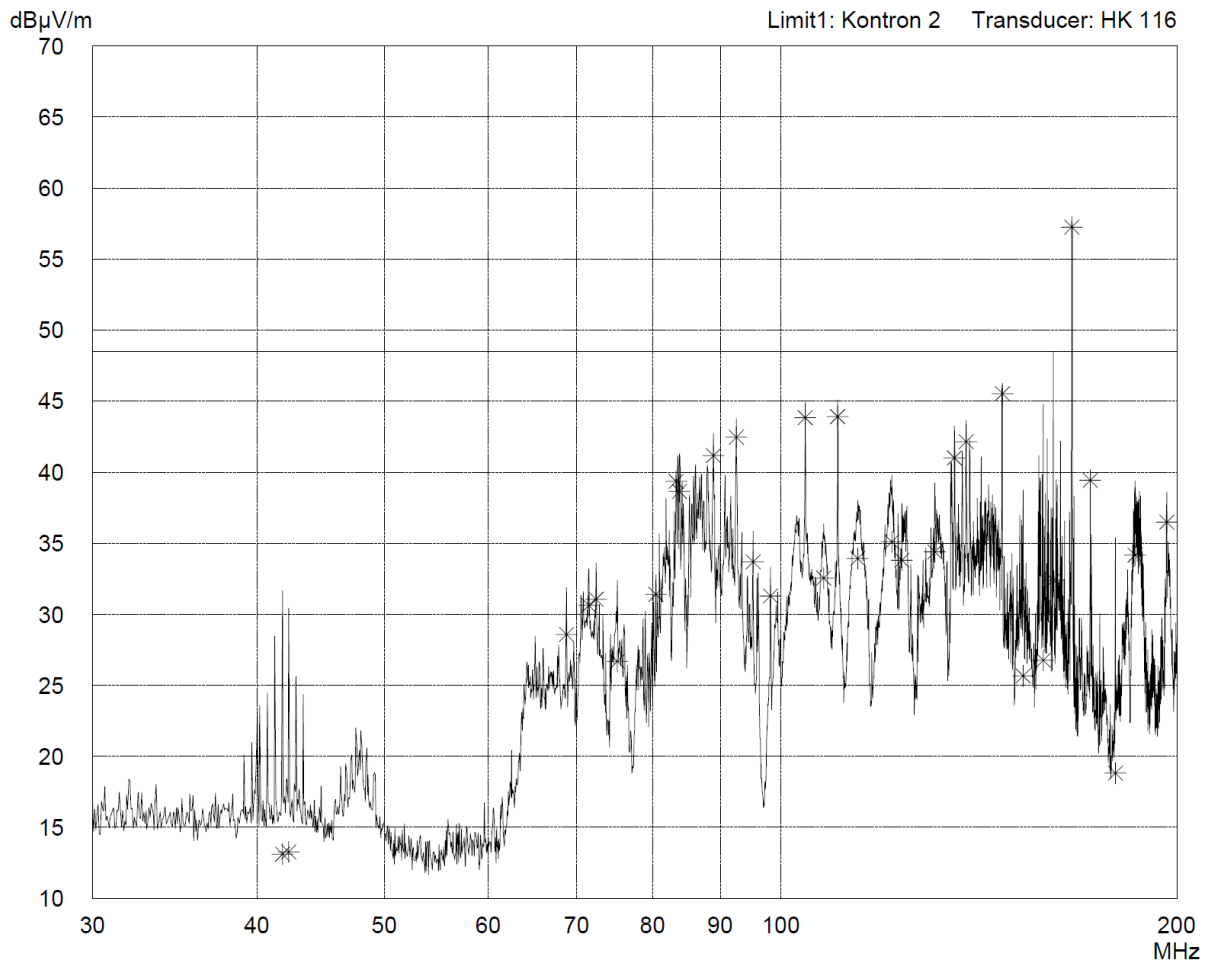

Radiated Emission Test 30 MHz - 200 MHz
acc. to KE_30MHz-200MHz

<p>Model: KISS 2U 45-y</p> <p>Serial no.: 001</p> <p>Applicant: Schiege K.</p> <p>Test site: Shielded room PM-EM-6172-1</p> <p>Tested on: Distance 1m Vertical Polarization</p> <p>Date of test: 03/10/2010</p> <p>Test performed: automatically</p>	<p>Comment: KISS 2U 45-y, 2-A0ED-20xx</p> <p>PSU: FSP400-60PFB AC</p> <p>Accessories: PS/2 Keyboard and PS/2 Mouse, 23" DVI LCD Display and Headset</p> <p>Connected data cables: VGA, COM1-2, LAN1-3 and USB1-8 (rear)</p> <p>- BitPro v6.0 test SW: 2D Graphic H-Pattern test</p> <p>- Display OFF</p> <p>- left side (270°)</p>
<p>Detector: Peak / Final Results: QP</p>	<p>Final results: 20 dB Margin 50 Subranges</p>

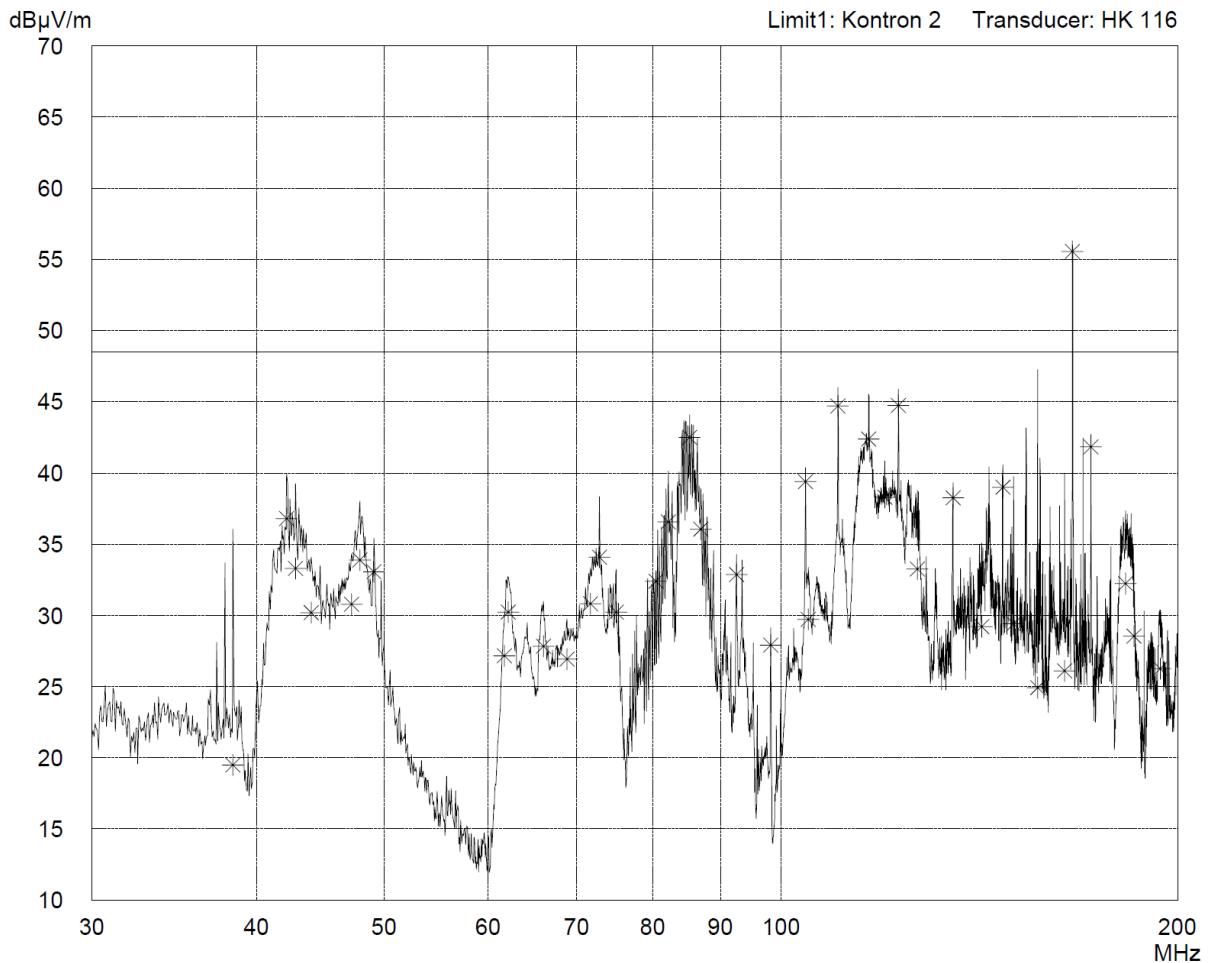

**Radiated Emission Test 200 MHz - 1 GHz
acc. to KE_200MHz-2GHz**

<p>Model: KISS 2U 45-y</p> <p>Serial no.: 001</p> <p>Applicant: Schiege K.</p> <p>Test site: Shielded room PM-EM-6172-1</p> <p>Tested on: Distance 1m Circular Polarization</p> <p>Date of test: 03/10/2010</p> <p>Test performed: automatically</p>	<p>Comment: KISS 2U 45-y, 2-A0ED-20xx</p> <p>PSU: FSP400-60PFB AC</p> <p>Accessories: PS/2 Keyboard and PS/2 Mouse, 23" DVI LCD Display and Headset</p> <p>Connected data cables: VGA, COM1-2, LAN1-3 and USB1-8 (rear)</p> <p>- BitPro v6.0 test SW: 2D Graphic H-Pattern test</p> <p>- Display OFF</p> <p>- left side (270°)</p>
<p>Detector: Peak / Final Results: QP</p>	<p>Final results: 20 dB Margin 50 Subranges</p>

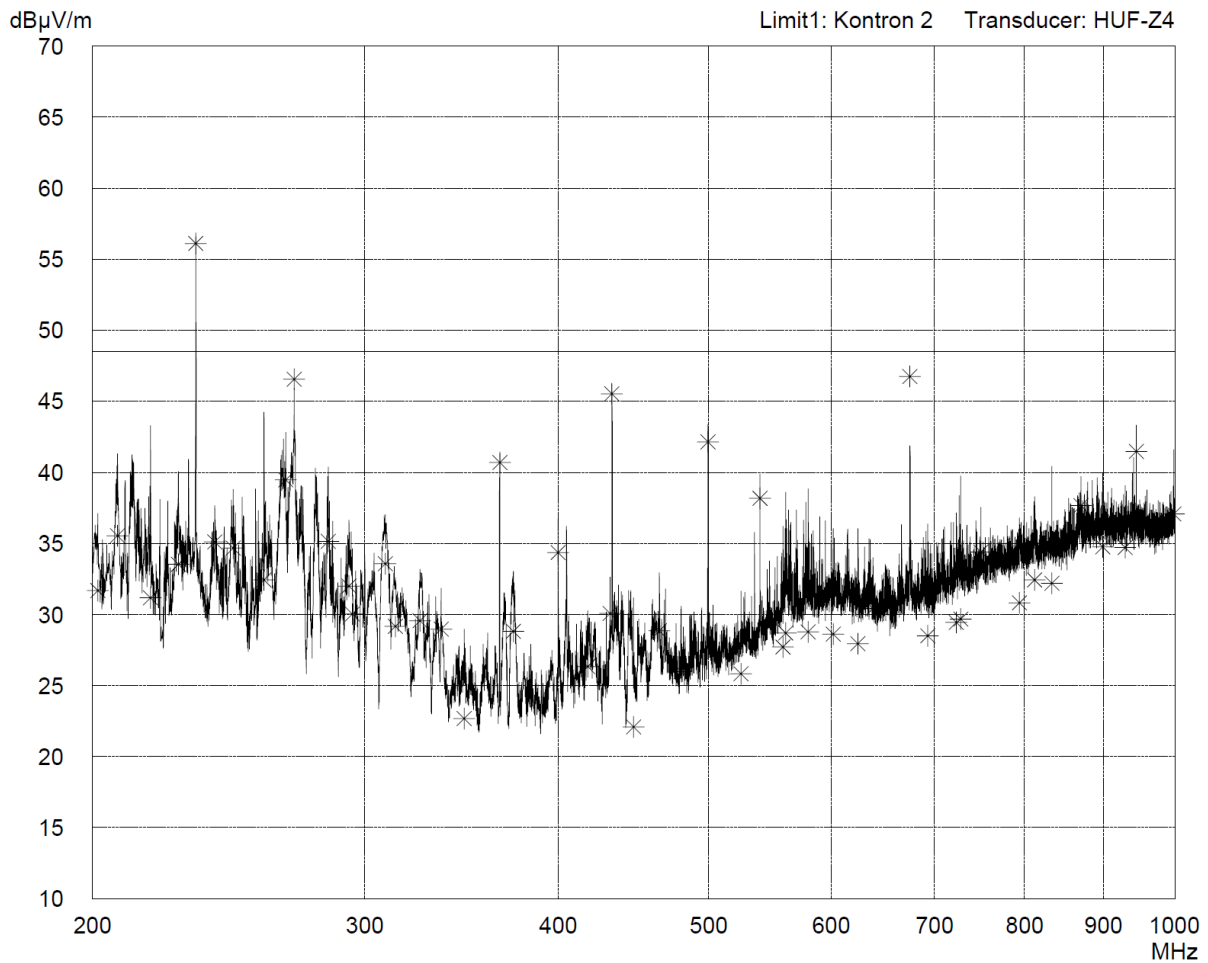

10.1.2 PSU2 - BES-630C 24VDC, Bicker

Conducted Emissions – Class B

Radiated emissions – Class A

**Conducted Emission Test 150 kHz - 30 MHz
acc. to EN 55022 Class B / CISPR 22**

<p>Model: KISS 2U 45-y</p> <p>Serial no.: 001</p> <p>Applicant: Schiege K.</p> <p>Test site: Shielded room PM-EM-6172-1</p> <p>Tested on: Signal and control lines LAN1</p> <p>Date of test: 01/20/2010</p> <p>Test performed: automatically</p>	<p>Comment: PSU: BES-630C 24 VDC - power 24 VDC from car batteries</p> <p>Accessories: PS/2 Keyboard and PS/2 Mouse, 23" DVI LCD Display</p> <p>Connected data cable: LAN1 (MB)</p> <p>- BitPro v6.0 test SW: LAN port 50% loaded</p> <p>- Display ON</p>
<p>Operator: Vesely P., Novak H.</p> <p>File name:</p>	<p>Final results: 20 dB Margin</p> <p style="text-align: right;">50 Subranges</p>

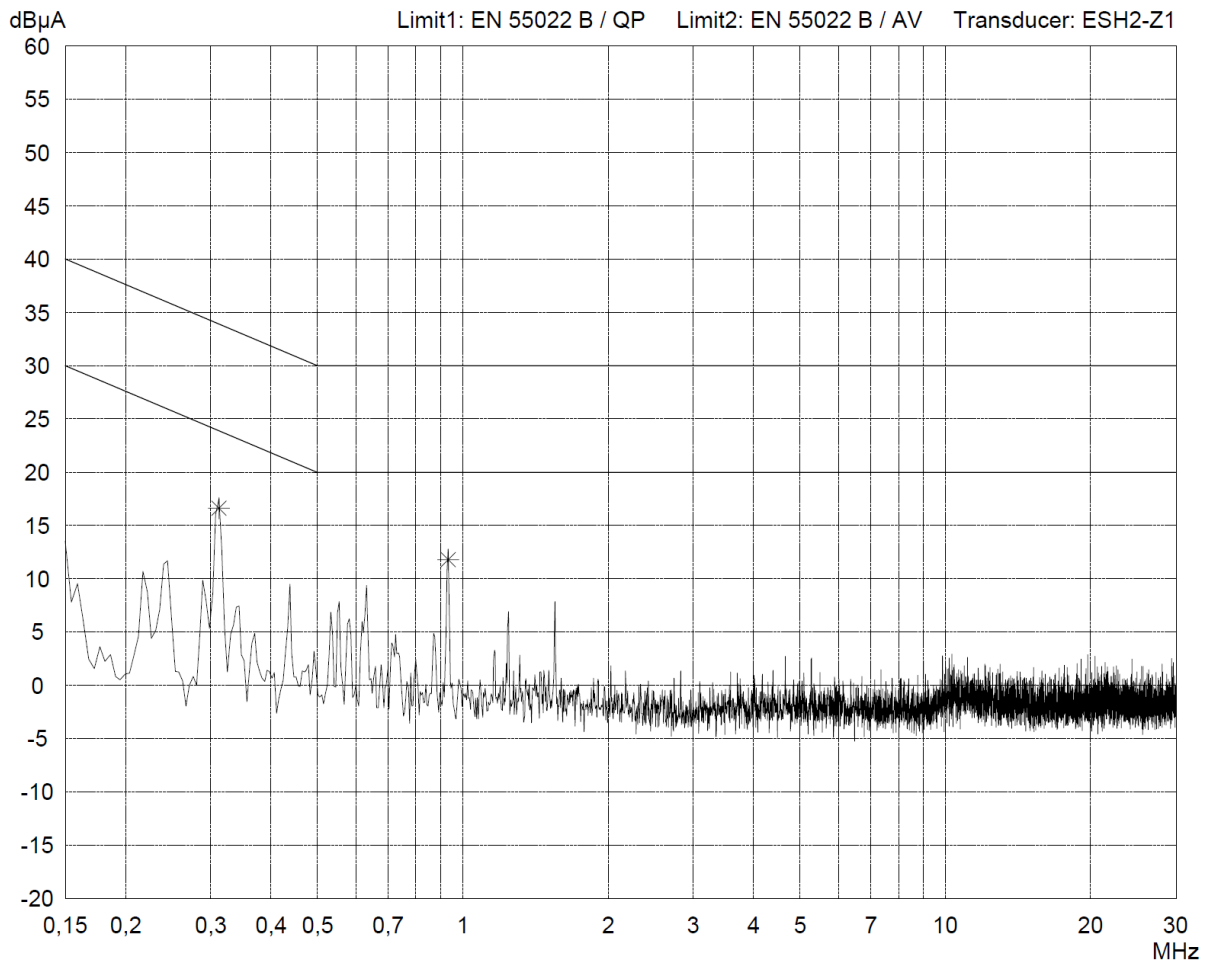

**Conducted Emission Test 150 kHz - 30 MHz
acc. to EN 55022 Class B / CISPR 22**

<p>Model: KISS 2U 45-y</p> <p>Serial no.: 001</p> <p>Applicant: Schiege K.</p> <p>Test site: Shielded room PM-EM-6172-1</p> <p>Tested on: Signal and control lines LAN2</p> <p>Date of test: 01/20/2010</p> <p>Test performed: automatically</p>	<p>Comment: PSU: BES-630C 24 VDC - power 24 VDC from car batteries</p> <p>Accessories: PS/2 Keyboard and PS/2 Mouse, 23" DVI LCD Display</p> <p>Connected data cable: LAN2 (MB)</p> <p>- BitPro v6.0 test SW: LAN port 50% loaded</p> <p>- Display ON</p>
<p>Operator: Vesely P., Novak H.</p> <p>File name:</p>	<p>Final results: 20 dB Margin 50 Subranges</p>

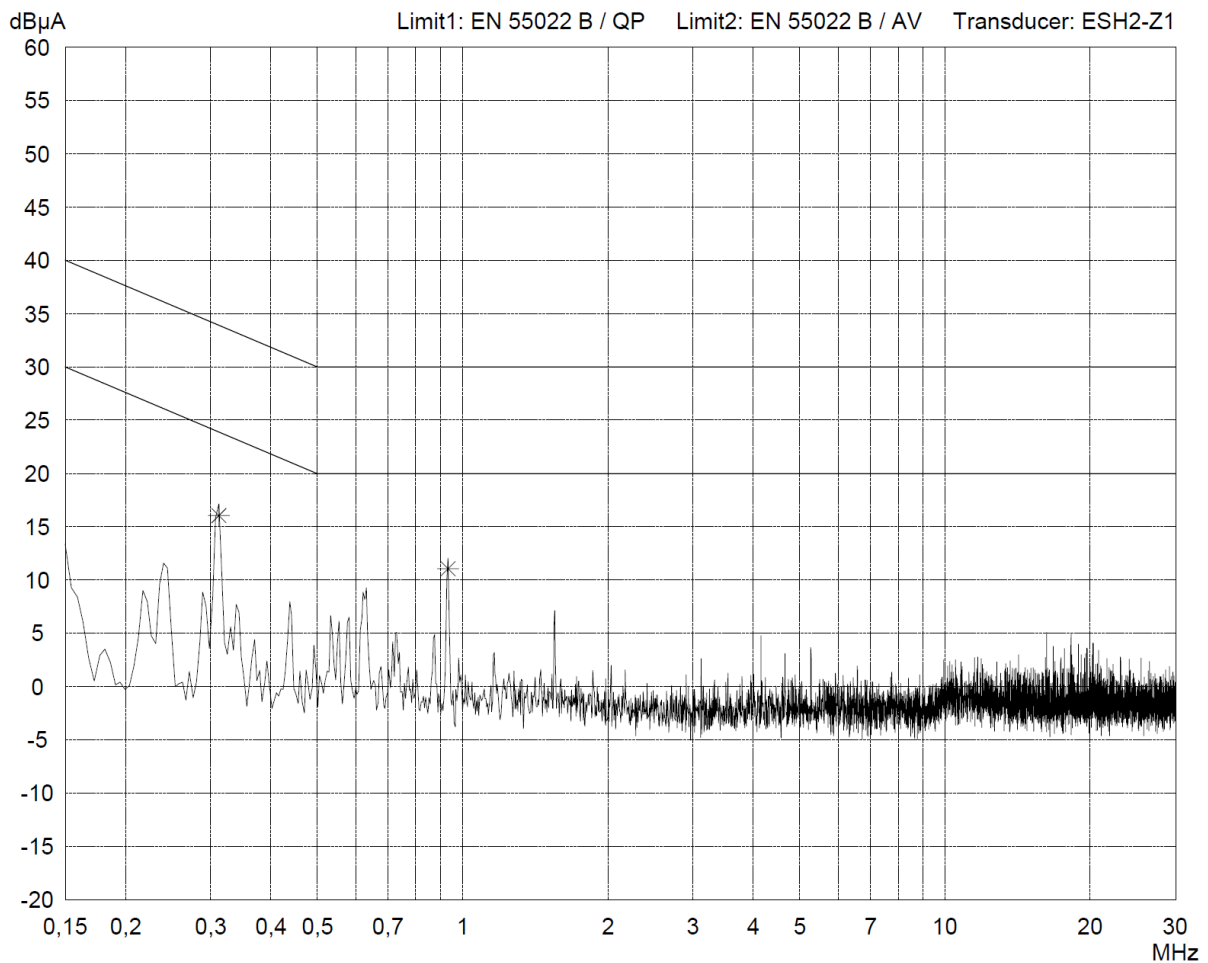

**Conducted Emission Test 150 kHz - 30 MHz
acc. to EN 55022 Class B / CISPR 22**

<p>Model: KISS 2U 45-y</p> <p>Serial no.: 001</p> <p>Applicant: Schiege K.</p> <p>Test site: Shielded room PM-EM-6172-1</p> <p>Tested on: Signal and control lines LAN3</p> <p>Date of test: 01/20/2010</p> <p>Test performed: automatically</p>	<p>Comment: PSU: BES-630C 24 VDC - power 24 VDC from car batteries</p> <p>Accessories: PS/2 Keyboard and PS/2 Mouse, 23" DVI LCD Display</p> <p>Connected data cable: LAN3 (PCI)</p> <p>- BitPro v6.0 test SW: LAN port 50% loaded</p> <p>- Display ON</p>
<p>Operator: Vesely P., Novak H.</p> <p>File name:</p>	<p>Final results: 20 dB Margin 50 Subranges</p>
<p>Detector: Peak / Final Results: QP</p>	

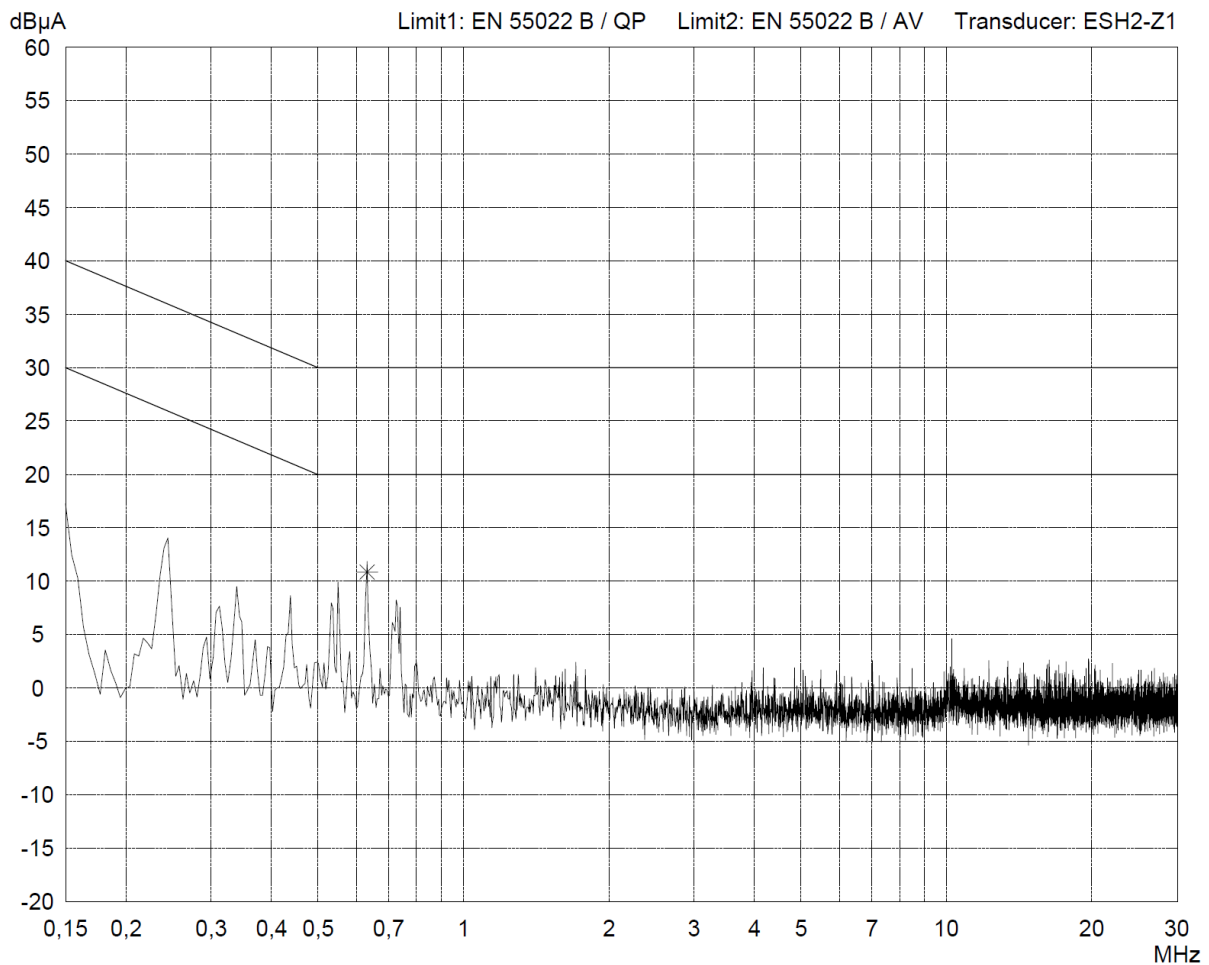

Radiated Emission Test 30 MHz - 200 MHz
acc. to KE_30MHz-200MHz

<p>Model: KISS 2U 45-y</p> <p>Serial no.: 001</p> <p>Applicant: Schiege K.</p> <p>Test site: Shielded room PM-EM-6172-1</p> <p>Tested on: Distance 1m Horizontal Polarization</p> <p>Date of test: 03/10/2010</p> <p>Test performed: automatically</p>	<p>Comment: KISS 2U 45-y, 2-A0ED-2xxx</p> <p>PSU: BES-630C 24 VDC - power from car batteries</p> <p>Accessories: PS/2 Keyboard and PS/2 Mouse, 23" DVI LCD Display and Headset</p> <p>Connected data cables: VGA, COM1-2, LAN1-3 and USB1-8 (rear)</p> <p>- BitPro v6.0 test SW: 2D Graphic H-Pattern test</p> <p>- Display OFF</p> <p>- front side (0°)</p>
<p>Operator: Vesely P.</p> <p>File name:</p>	<p>Final results: 20 dB Margin</p> <p style="text-align: right;">50 Subranges</p>
<p>Detector: Peak / Final Results: QP</p>	

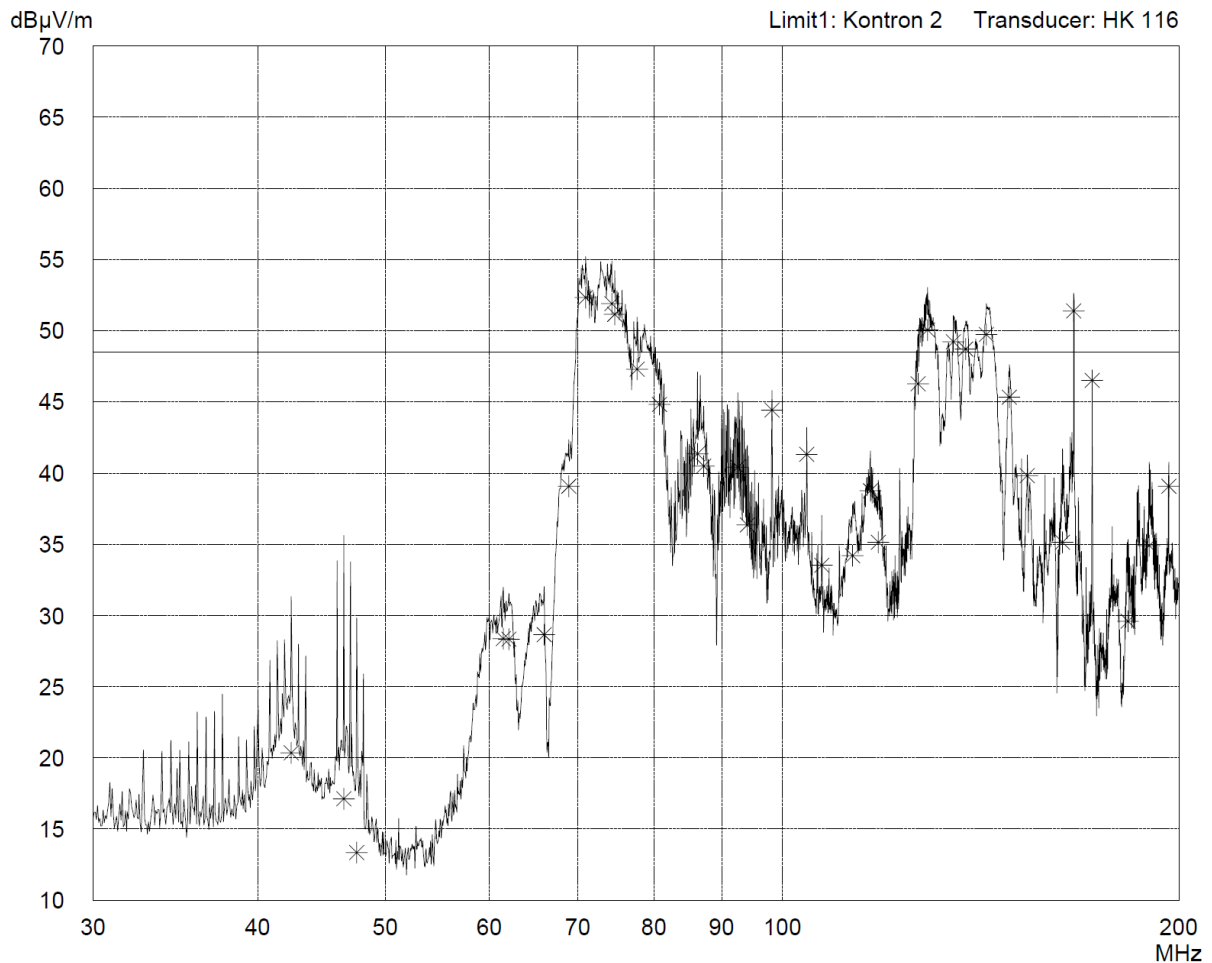

**Radiated Emission Test 30 MHz - 200 MHz
acc. to KE_30MHz-200MHz**

<p>Model: KISS 2U 45-y</p> <p>Serial no.: 001</p> <p>Applicant: Schiege K.</p> <p>Test site: Shielded room PM-EM-6172-1</p> <p>Tested on: Distance 1m Vertical Polarization</p> <p>Date of test: 03/10/2010</p> <p>Test performed: automatically</p>	<p>Comment: KISS 2U 45-y, 2-A0ED-2xxx</p> <p>PSU: BES-630C 24 VDC - power from car batteries</p> <p>Accessories: PS/2 Keyboard and PS/2 Mouse, 23" DVI LCD Display and Headset</p> <p>Connected data cables: VGA, COM1-2, LAN1-3 and USB1-8 (rear)</p> <p>- BitPro v6.0 test SW: 2D Graphic H-Pattern test</p> <p>- Display OFF</p> <p>- front side (0°)</p>
<p>Detector: Peak / Final Results: QP</p>	<p>Final results: 20 dB Margin 50 Subranges</p>

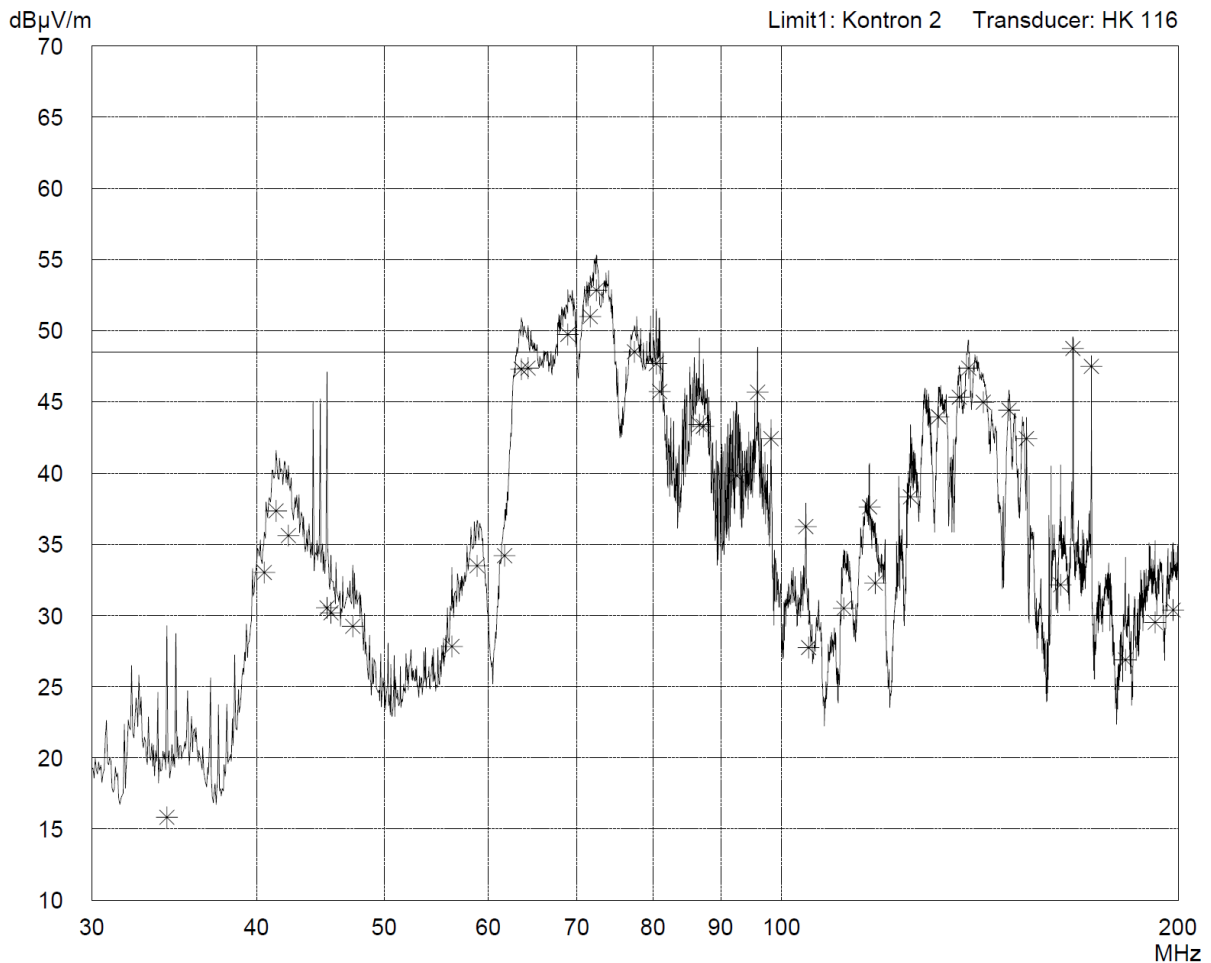

**Radiated Emission Test 200 MHz - 1 GHz
acc. to KE_200MHz-2GHz**

<table border="1" style="width: 100%; border-collapse: collapse;"> <tr> <td style="padding: 2px;">Model: KISS 2U 45-y</td> </tr> <tr> <td style="padding: 2px;">Serial no.: 001</td> </tr> <tr> <td style="padding: 2px;">Applicant: Schiege K.</td> </tr> <tr> <td style="padding: 2px;">Test site: Shielded room PM-EM-6172-1</td> </tr> <tr> <td style="padding: 2px;">Tested on: Distance 1m Circular Polarization</td> </tr> <tr> <td style="padding: 2px;">Date of test: 03/10/2010</td> <td style="padding: 2px;">Operator: Vesely P.</td> </tr> <tr> <td style="padding: 2px;">Test performed: automatically</td> <td style="padding: 2px;">File name:</td> </tr> </table>	Model: KISS 2U 45-y	Serial no.: 001	Applicant: Schiege K.	Test site: Shielded room PM-EM-6172-1	Tested on: Distance 1m Circular Polarization	Date of test: 03/10/2010	Operator: Vesely P.	Test performed: automatically	File name:	<p>Comment: KISS 2U 45-y, 2-A0ED-2xxx</p> <p>PSU: BES-630C 24 VDC - power from car batteries</p> <p>Accessories: PS/2 Keyboard and PS/2 Mouse, 23" DVI LCD Display and Headset</p> <p>Connected data cables: VGA, COM1-2, LAN1-3 and USB1-8 (rear)</p> <p>- BitPro v6.0 test SW: 2D Graphic H-Pattern test</p> <p>- Display OFF</p> <p>- front side (0°)</p>
Model: KISS 2U 45-y										
Serial no.: 001										
Applicant: Schiege K.										
Test site: Shielded room PM-EM-6172-1										
Tested on: Distance 1m Circular Polarization										
Date of test: 03/10/2010	Operator: Vesely P.									
Test performed: automatically	File name:									
Detector: Peak / Final Results: QP	Final results: 20 dB Margin 50 Subranges									

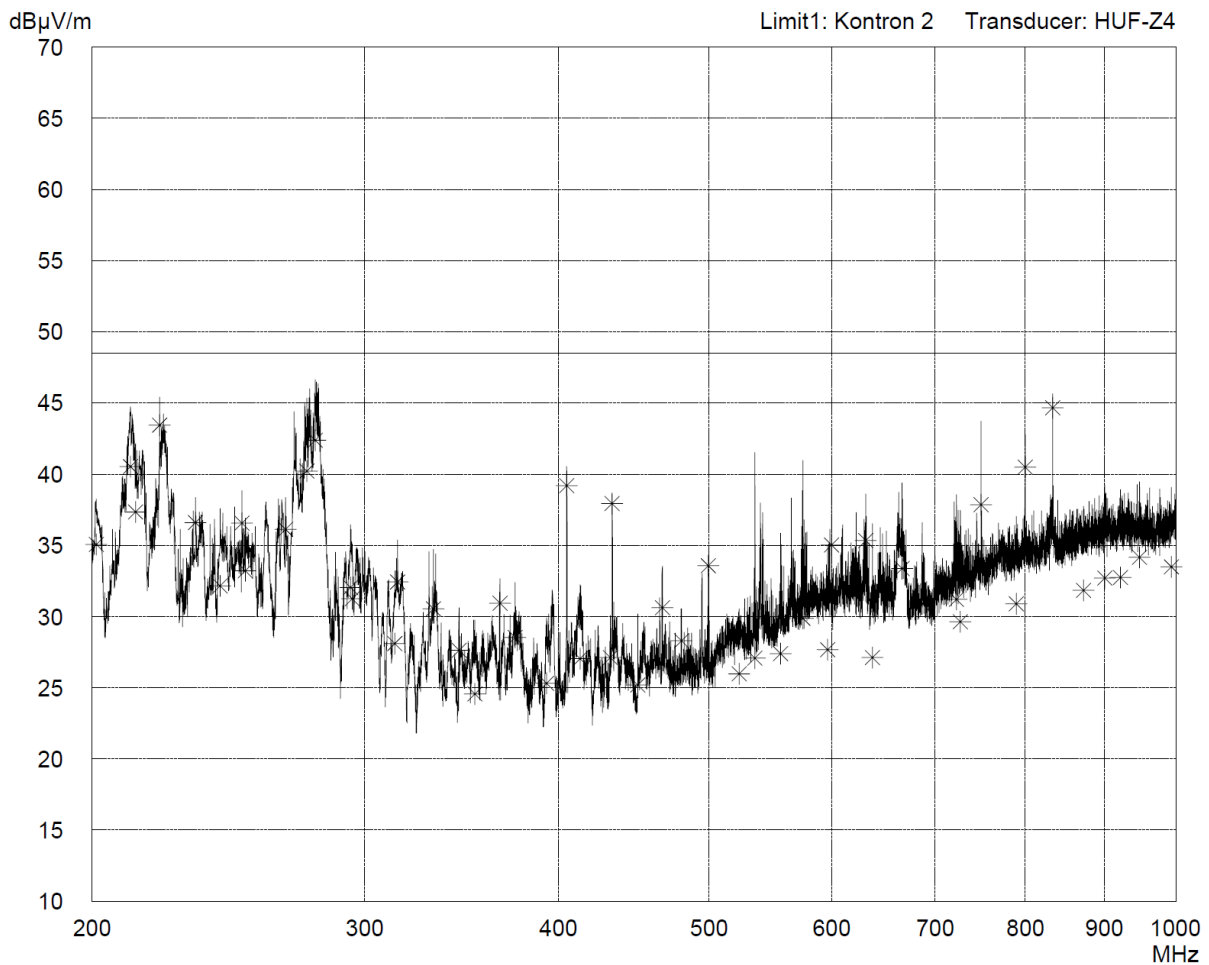

**Radiated Emission Test 30 MHz - 200 MHz
acc. to KE_30MHz-200MHz**

<p>Model: KISS 2U 45-y</p> <p>Serial no.: 001</p> <p>Applicant: Schiege K.</p> <p>Test site: Shielded room PM-EM-6172-1</p> <p>Tested on: Distance 1m Horizontal Polarization</p> <p>Date of test: 03/10/2010</p> <p>Test performed: automatically</p>	<p>Comment: KISS 2U 45-y, 2-A0ED-20xx</p> <p>PSU: FSP400-60PFB AC</p> <p>Accessories: PS/2 Keyboard and PS/2 Mouse, 23" DVI LCD Display and Headset</p> <p>Connected data cables: VGA, COM1-2, LAN1-3 and USB1-8 (rear)</p> <p>- BitPro v6.0 test SW: 2D Graphic H-Pattern test</p> <p>- Display OFF</p> <p>- interface side (180°)</p>
<p>Detector: Peak / Final Results: QP</p>	<p>Final results: 20 dB Margin 50 Subranges</p>

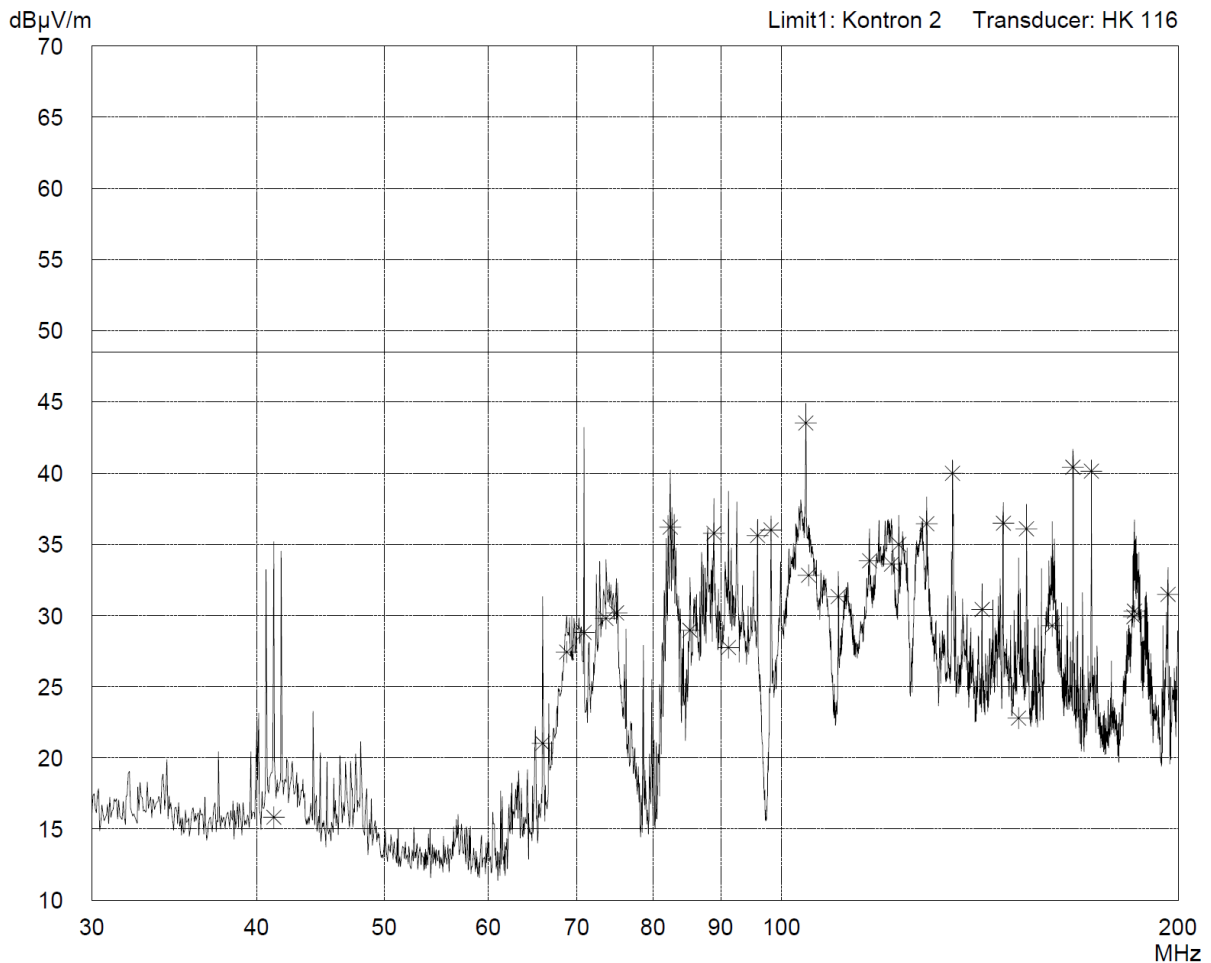

**Radiated Emission Test 200 MHz - 1 GHz
acc. to KE_200MHz-2GHz**

<p>Model: KISS 2U 45-y</p> <p>Serial no.: 001</p> <p>Applicant: Schiege K.</p> <p>Test site: Shielded room PM-EM-6172-1</p> <p>Tested on: Distance 1m Circular Polarization</p> <p>Date of test: 03/10/2010</p> <p>Test performed: automatically</p>	<p>Comment: KISS 2U 45-y, 2-A0ED-20xx</p> <p>PSU: FSP400-60PFB AC</p> <p>Accessories: PS/2 Keyboard and PS/2 Mouse, 23" DVI LCD Display and Headset</p> <p>Connected data cables: VGA, COM1-2, LAN1-3 and USB1-8 (rear)</p> <p>- BitPro v6.0 test SW: 2D Graphic H-Pattern test</p> <p>- Display OFF</p> <p>- interface side (180°)</p>
<p>Detector: Peak / Final Results: QP</p>	<p>Final results: 20 dB Margin 50 Subranges</p>

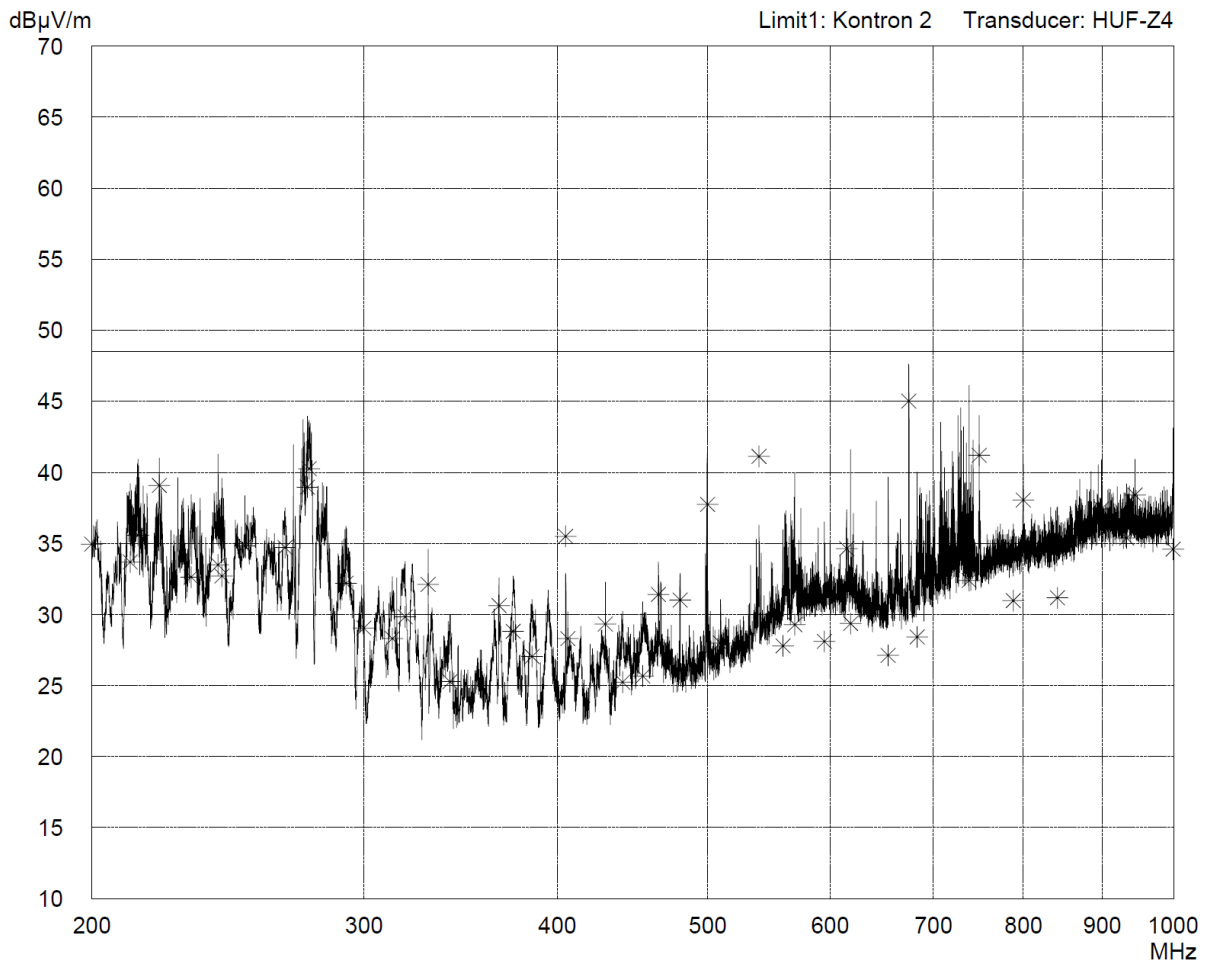

**Radiated Emission Test 30 MHz - 200 MHz
acc. to KE_30MHz-200MHz**

<p>Model: KISS 2U 45-y</p> <p>Serial no.: 001</p> <p>Applicant: Schiege K.</p> <p>Test site: Shielded room PM-EM-6172-1</p> <p>Tested on: Distance 1m Horizontal Polarization</p> <p>Date of test: 03/10/2010</p> <p>Test performed: automatically</p>	<p>Comment: KISS 2U 45-y, 2-A0ED-20xx</p> <p>PSU: FSP400-60PFB AC</p> <p>Accessories: PS/2 Keyboard and PS/2 Mouse, 23" DVI LCD Display and Headset</p> <p>Connected data cables: VGA, COM1-2, LAN1-3 and USB1-8 (rear)</p> <p>- BitPro v6.0 test SW: 2D Graphic H-Pattern test</p> <p>- Display OFF</p> <p>- left side (270°)</p>
<p>Detector: Peak / Final Results: QP</p>	<p>Final results: 20 dB Margin 50 Subranges</p>

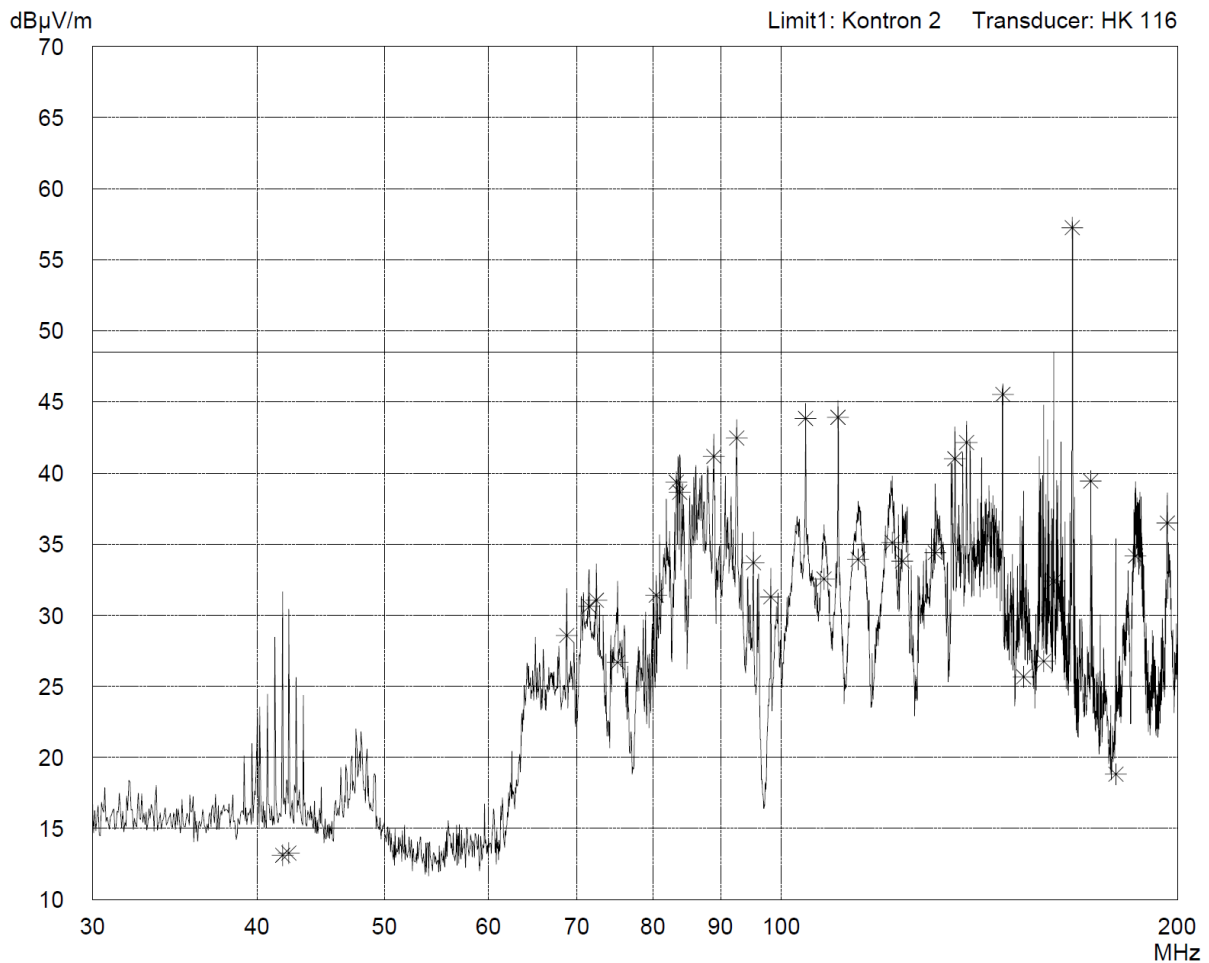

Radiated Emission Test 30 MHz - 200 MHz
acc. to KE_30MHz-200MHz

Model: KISS 2U 45-y	Comment: KISS 2U 45-y, 2-A0ED-20xx PSU: FSP400-60PFB AC Accessories: PS/2 Keyboard and PS/2 Mouse, 23" DVI LCD Display and Headset Connected data cables: VGA, COM1-2, LAN1-3 and USB1-8 (rear) - BitPro v6.0 test SW: 2D Graphic H-Pattern test - Display OFF - left side (270°)	
Serial no.: 001		
Applicant: Schiege K.		
Test site: Shielded room PM-EM-6172-1		
Tested on: Distance 1m Vertical Polarization		
Date of test: 03/10/2010		Operator: Vesely P.
Test performed: automatically		File name:
Detector: Peak / Final Results: QP	Final results: 20 dB Margin 50 Subranges	

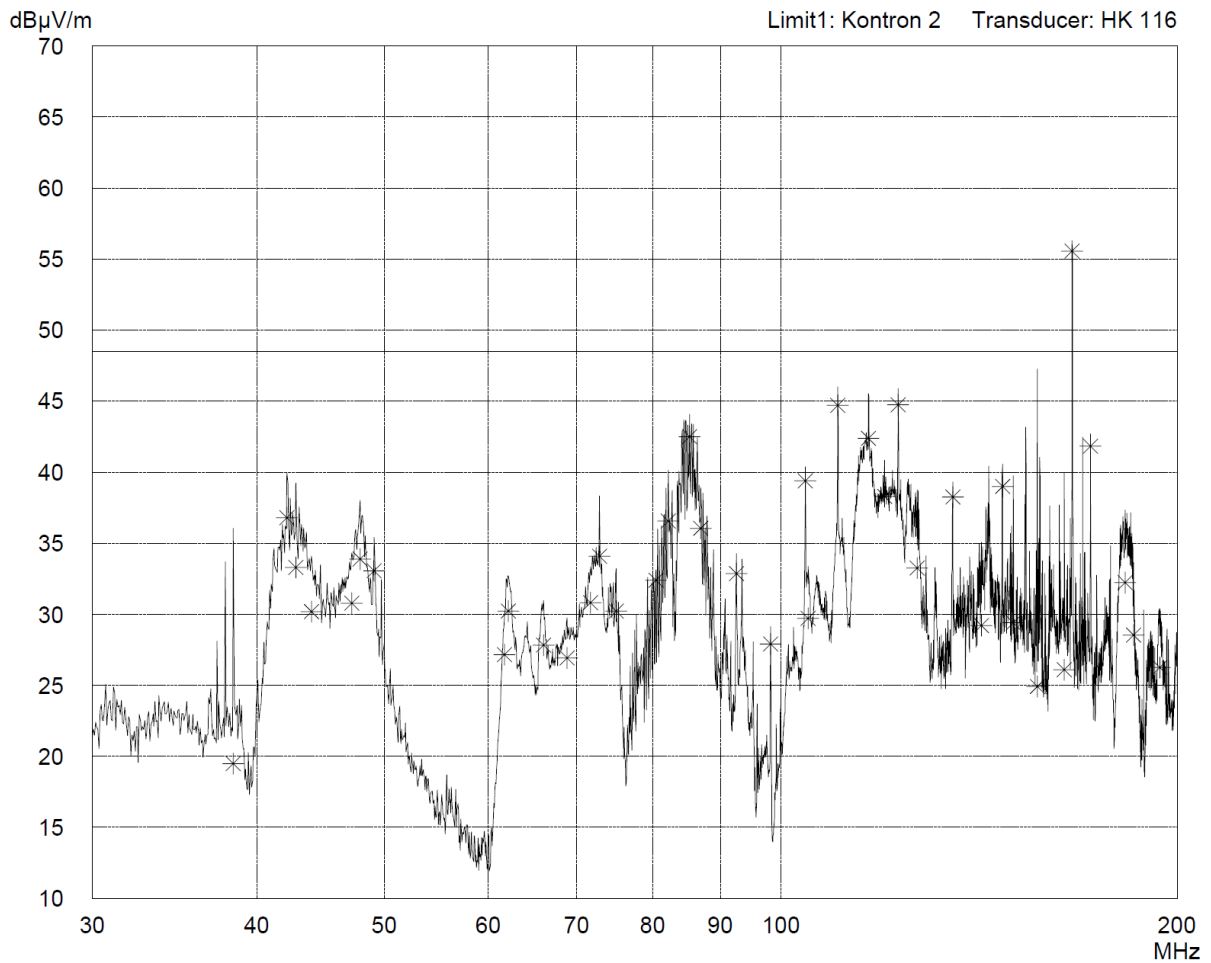

Radiated Emission Test 200 MHz - 1 GHz
acc. to KE_200MHz-2GHz

<p>Model: KISS 2U 45-y</p> <p>Serial no.: 001</p> <p>Applicant: Schiege K.</p> <p>Test site: Shielded room PM-EM-6172-1</p> <p>Tested on: Distance 1m Circular Polarization</p> <p>Date of test: 03/10/2010</p> <p>Test performed: automatically</p>	<p>Comment: KISS 2U 45-y, 2-A0ED-20xx</p> <p>PSU: FSP400-60PFB AC</p> <p>Accessories: PS/2 Keyboard and PS/2 Mouse, 23" DVI LCD Display and Headset</p> <p>Connected data cables: VGA, COM1-2, LAN1-3 and USB1-8 (rear)</p> <p>- BitPro v6.0 test SW: 2D Graphic H-Pattern test</p> <p>- Display OFF</p> <p>- left side (270°)</p>
<p>Detector: Peak / Final Results: QP</p>	<p>Final results: 20 dB Margin 50 Subranges</p>

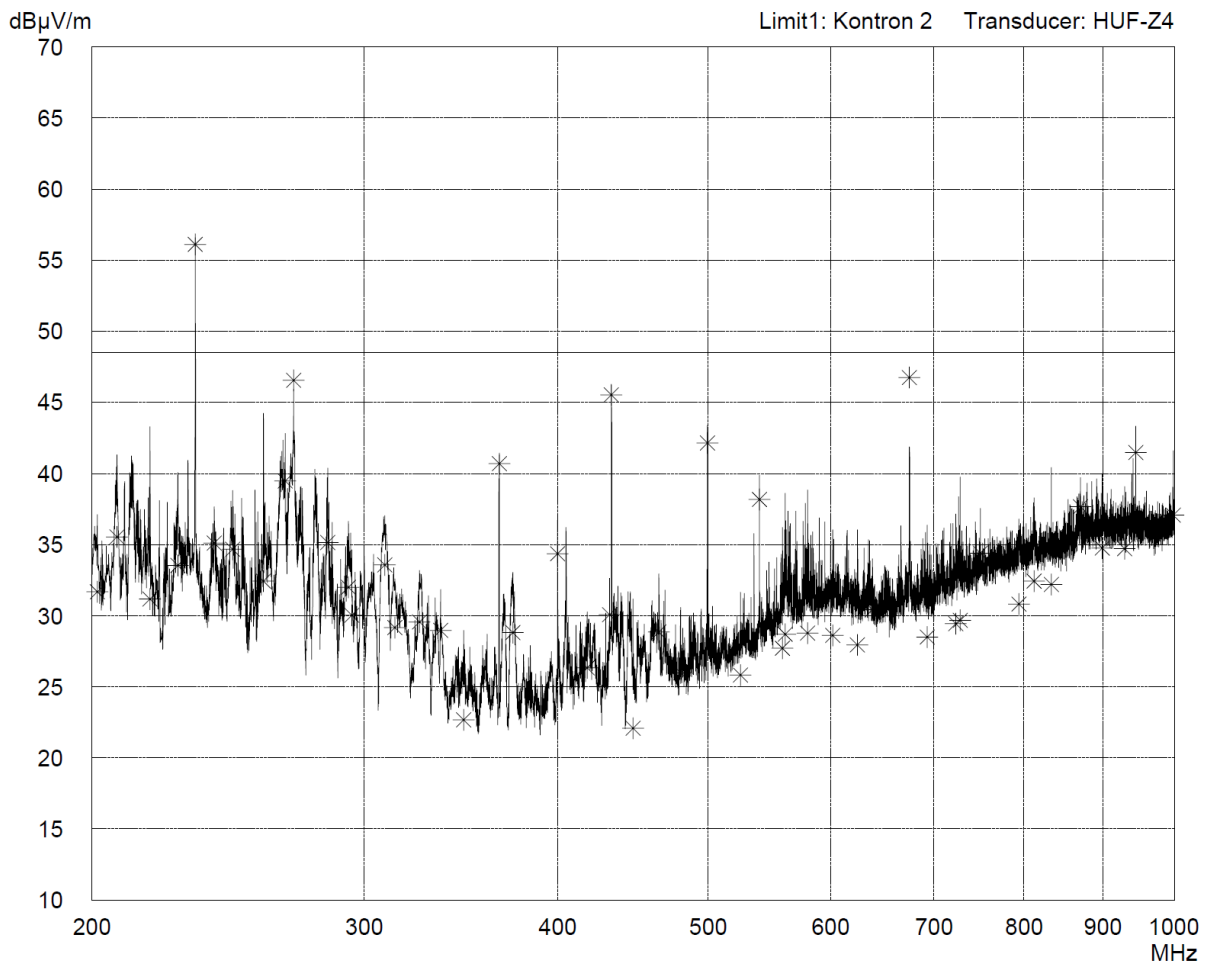

10.1.3 R1S2-5380V4V AC red., Bicker

Conducted Emissions – Class B

Radiated emissions – Class A

**Conducted Emission Test 150 kHz - 30 MHz
acc. to EN 55022 Class B / CISPR 22**

<p>Model: KISS 2U 45-y</p> <p>Serial no.: 001</p> <p>Applicant: Schiege K.</p> <p>Test site: Shielded room PM-EM-6172-1</p> <p>Tested on: Linecord Phase L1</p> <p>Date of test: 03/11/2010 Operator: Vesely P.</p> <p>Test performed: automatically File name:</p>	<p>Comment: KISS 2U 45-y, 2-A0ED-2xxx</p> <p>PSU: Bicker R1S2-5380V4V AC red.</p> <p>Accessories: PS/2 Keyboard and PS/2 Mouse, 23" DVI LCD Display and Headset</p> <p>Connected data cables: VGA, COM1-2, LAN1-3 and USB1-8 (rear)</p> <p>- BitPro v6.0 test SW: 2D Graphic H-Pattern test</p> <p>- Display OFF</p> <p>- front side (0°)</p>
<p>Detector: Peak / Final Results: QP</p>	<p>Final results: 20 dB Margin 50 Subranges</p>

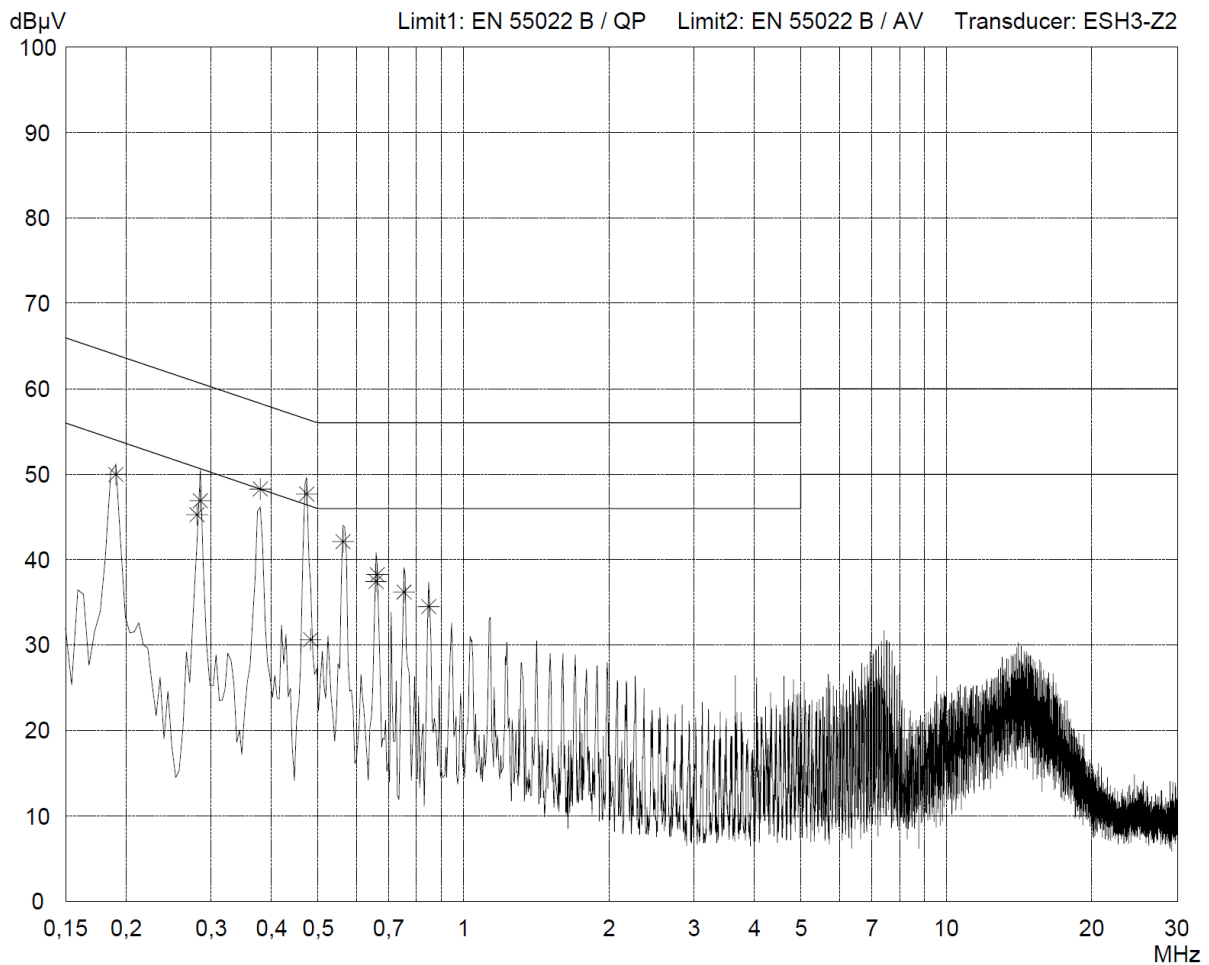

**Conducted Emission Test 150 kHz - 30 MHz
acc. to EN 55022 Class B / CISPR 22**

Model: KISS 2U 45-y	Comment: KISS 2U 45-y, 2-A0ED-2xxx
Serial no.: 001	PSU: Bicker R1S2-5380V4V AC red.
Applicant: Schiege K.	Accessories: PS/2 Keyboard and PS/2 Mouse, 23" DVI LCD Display and Headset
Test site: Shielded room PM-EM-6172-1	Connected data cables: VGA, COM1-2, LAN1-3 and USB1-8 (rear)
Tested on: Linecord Phase L1	- BitPro v6.0 test SW: 2D Graphic H-Pattern test
Date of test: 03/11/2010	Operator: Vesely P.
Test performed: automatically	File name:
Detector: Average	List of values: 20 dB Margin 50 Subranges

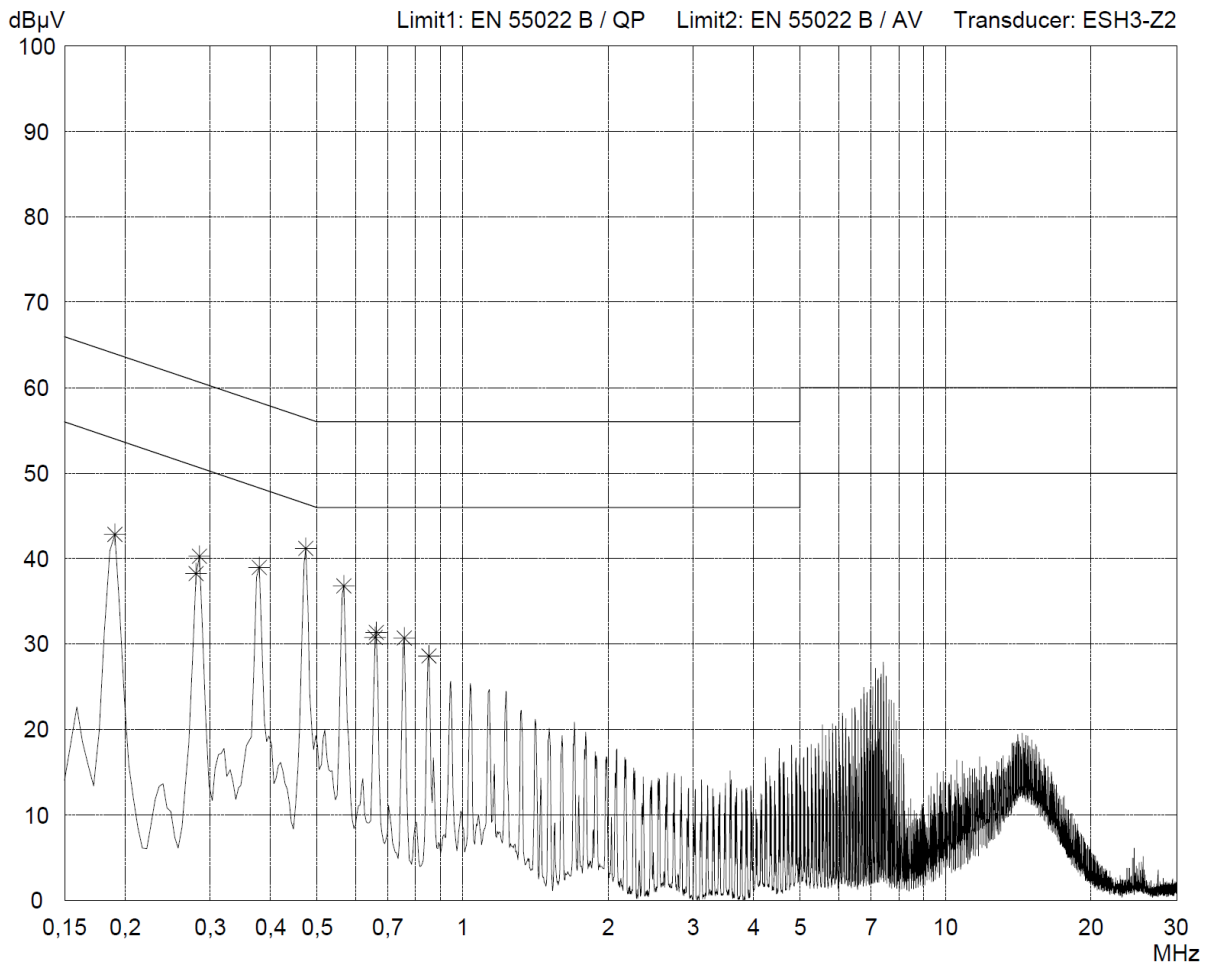

**Conducted Emission Test 150 kHz - 30 MHz
acc. to EN 55022 Class B / CISPR 22**

<p>Model: KISS 2U 45-y</p> <p>Serial no.: 001</p> <p>Applicant: Schiege K.</p> <p>Test site: Shielded room PM-EM-6172-1</p> <p>Tested on: Linecord Phase N</p> <p>Date of test: 03/11/2010</p> <p>Test performed: automatically</p>	<p>Comment: KISS 2U 45-y, 2-A0ED-2xxx</p> <p>PSU: Bicker R1S2-5380V4V AC red.</p> <p>Accessories: PS/2 Keyboard and PS/2 Mouse, 23" DVI LCD Display and Headset</p> <p>Connected data cables: VGA, COM1-2, LAN1-3 and USB1-8 (rear)</p> <p>- BitPro v6.0 test SW: 2D Graphic H-Pattern test</p> <p>- Display OFF</p> <p>- front side (0°)</p>
<p>Detector: Peak / Final Results: QP</p>	<p>Final results: 20 dB Margin 50 Subranges</p>

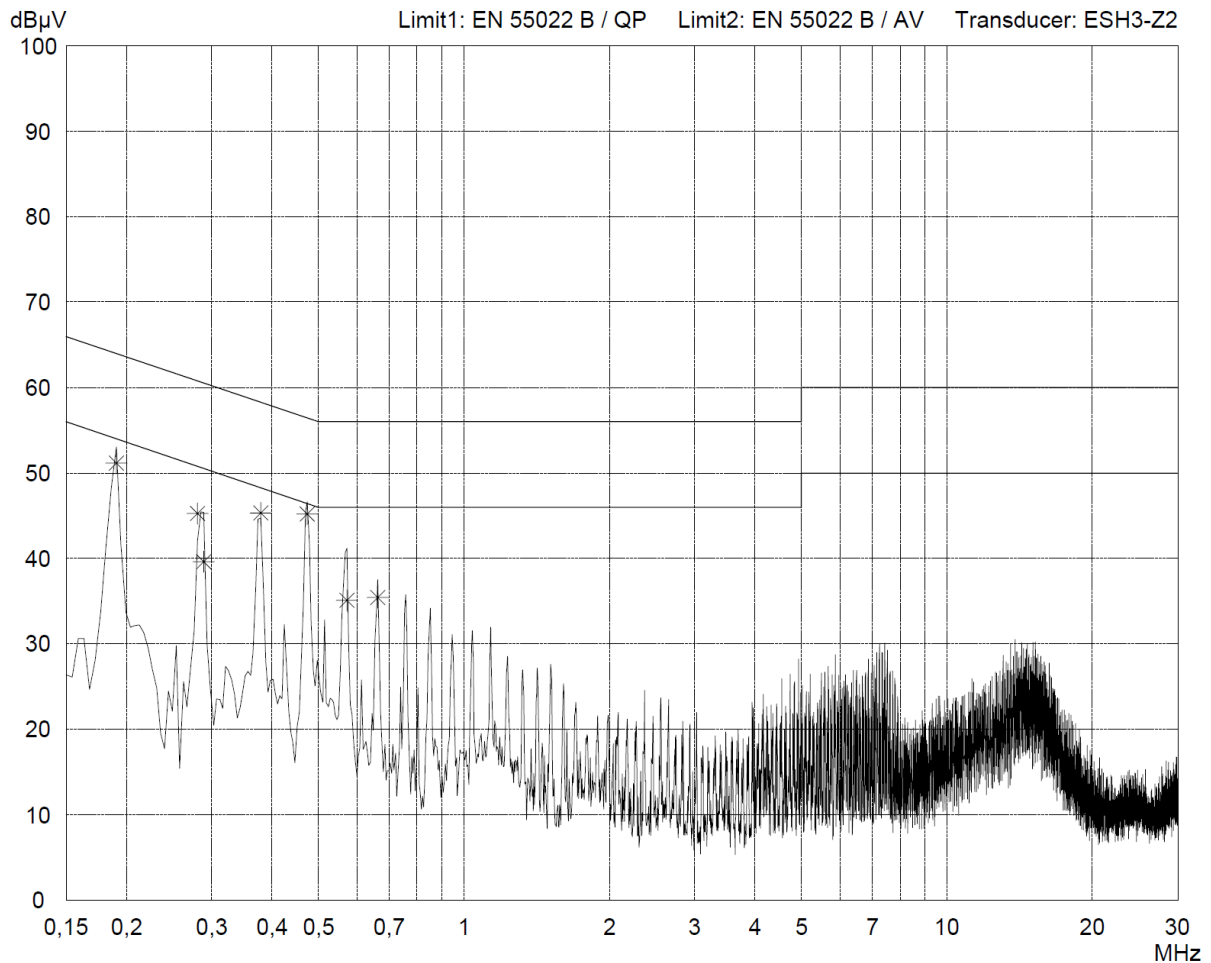

**Conducted Emission Test 150 kHz - 30 MHz
acc. to EN 55022 Class B / CISPR 22**

<p>Model: KISS 2U 45-y</p> <p>Serial no.: 001</p> <p>Applicant: Schiege K.</p> <p>Test site: Shielded room PM-EM-6172-1</p> <p>Tested on: Linecord Phase N</p> <p>Date of test: 03/11/2010</p> <p>Test performed: automatically</p>	<p>Comment: KISS 2U 45-y, 2-A0ED-2xxx</p> <p>PSU: Bicker R1S2-5380V4V AC red.</p> <p>Accessories: PS/2 Keyboard and PS/2 Mouse, 23" DVI LCD Display and Headset</p> <p>Connected data cables: VGA, COM1-2, LAN1-3 and USB1-8 (rear)</p> <p>- BitPro v6.0 test SW: 2D Graphic H-Pattern test</p> <p>- Display OFF</p> <p>- front side (0°)</p>
<p>Detector: Average</p>	<p>List of values: 20 dB Margin 50 Subranges</p>

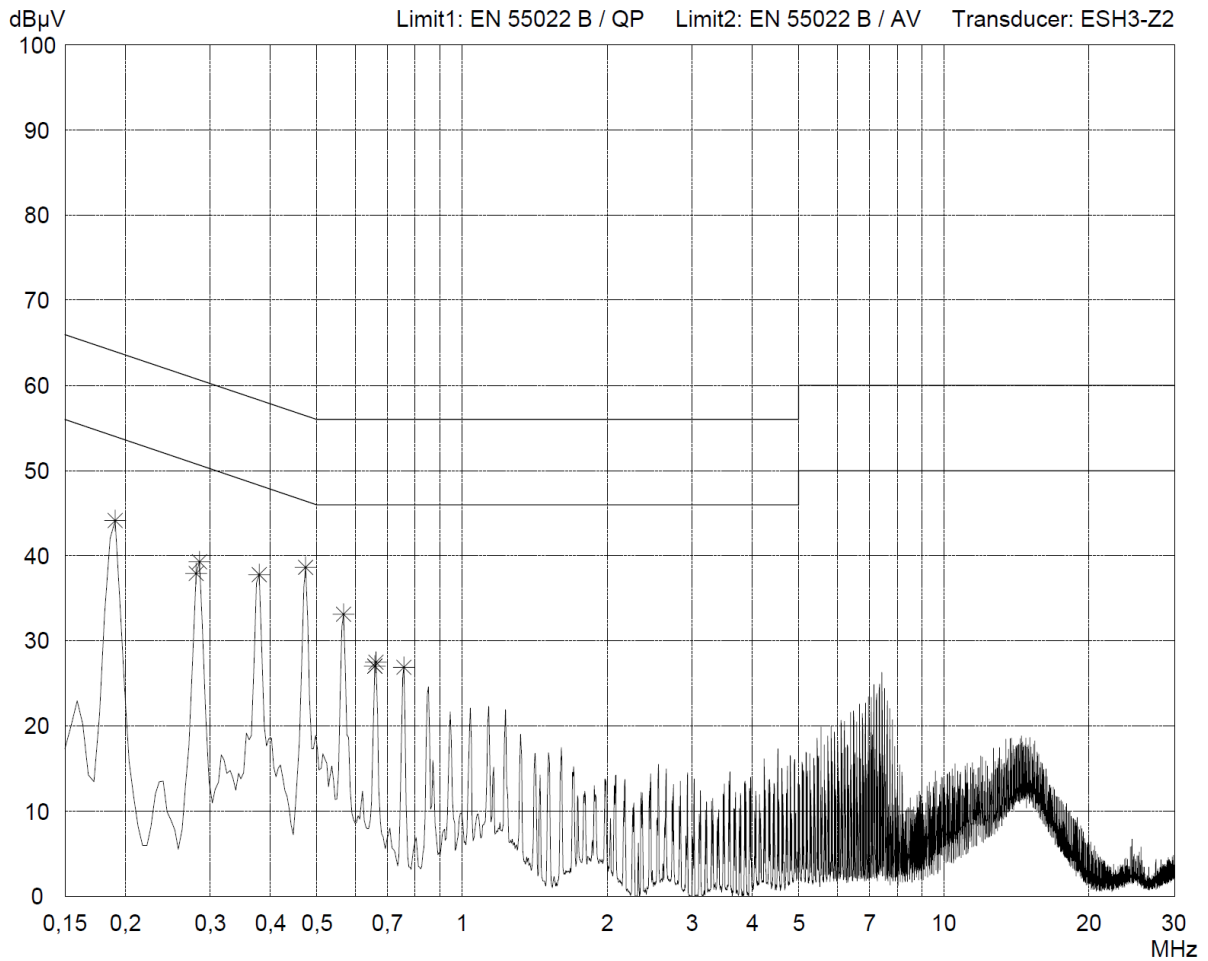

**Conducted Emission Test 150 kHz - 30 MHz
acc. to EN 55022 Class B / CISPR 22**

<p>Model: KISS 2U 45-y</p> <p>Serial no.: 001</p> <p>Applicant: Schiege K.</p> <p>Test site: Shielded room PM-EM-6172-1</p> <p>Tested on: Signal and control lines LAN1</p> <p>Date of test: 01/20/2010</p> <p>Test performed: automatically</p>	<p>Comment: PSU: Bicker R1S2-5380V4V AC redundant</p> <p>Accessories: PS/2 Keyboard and PS/2 Mouse, 23" DVI LCD Display</p> <p>Connected data cable: LAN1</p> <p>- BitPro v6.0 test SW: LAN port 50% loaded</p> <p>- Display ON</p>
<p>Operator: Vesely P., Novak H.</p> <p>File name:</p>	<p>Final results: 20 dB Margin 50 Subranges</p>
<p>Detector: Peak / Final Results: QP</p>	

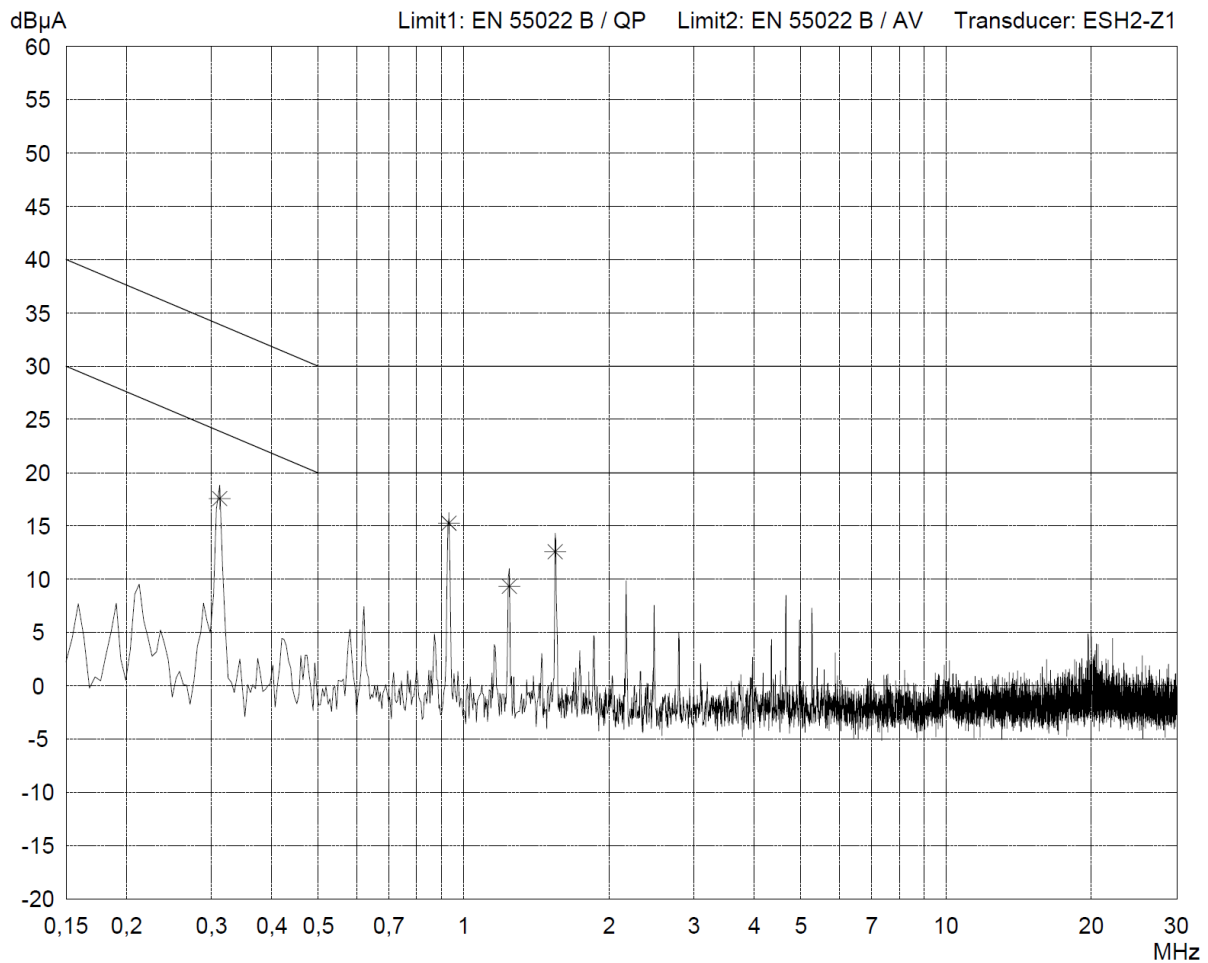

**Conducted Emission Test 150 kHz - 30 MHz
acc. to EN 55022 Class B / CISPR 22**

<p>Model: KISS 2U 45-y</p> <p>Serial no.: 001</p> <p>Applicant: Schiege K.</p> <p>Test site: Shielded room PM-EM-6172-1</p> <p>Tested on: Signal and control lines LAN2</p> <p>Date of test: 01/20/2010</p> <p>Test performed: automatically</p>	<p>Operator: Vesely P., Novak H.</p> <p>File name:</p> <p>Comment: PSU: Bicker R1S2-5380V4V AC redundant</p> <p>Accessories: PS/2 Keyboard and PS/2 Mouse, 23" DVI LCD Display</p> <p>Connected data cable: LAN2</p> <p>- BitPro v6.0 test SW: LAN port 50% loaded</p> <p>- Display ON</p>
<p>Detector: Peak / Final Results: QP</p>	<p>Final results: 20 dB Margin 50 Subranges</p>

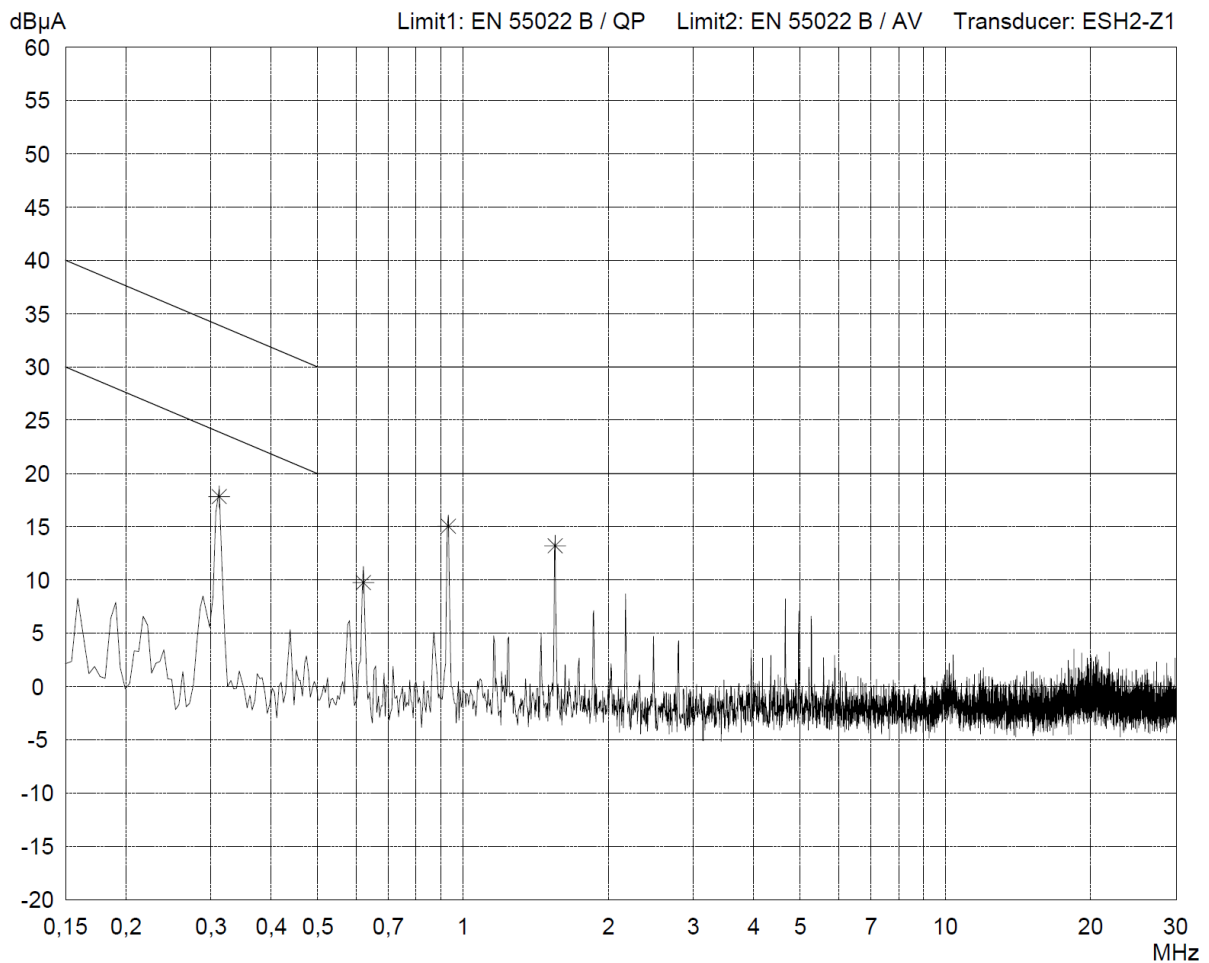

**Radiated Emission Test 30 MHz - 200 MHz
acc. to KE_30MHz-200MHz**

<p>Model: KISS 2U 45-y</p> <p>Serial no.: 001</p> <p>Applicant: Schiege K.</p> <p>Test site: Shielded room PM-EM-6172-1</p> <p>Tested on: Distance 1m Horizontal Polarization</p> <p>Date of test: 03/11/2010</p> <p>Operator: Vesely P.</p> <p>Test performed: automatically</p> <p>File name:</p>	<p>Comment: KISS 2U 45-y, 2-A0ED-2xxx</p> <p>PSU: Bicker R1S2-5380V4V AC red.</p> <p>Accessories: PS/2 Keyboard and PS/2 Mouse, 23" DVI LCD Display and Headset</p> <p>Connected data cables: VGA, COM1-2, LAN1-3 and USB1-8 (rear)</p> <p>- BitPro v6.0 test SW: 2D Graphic H-Pattern test</p> <p>- Display OFF</p> <p>- front side (0°)</p>
<p>Detector: Peak / Final Results: QP</p>	<p>Final results: 20 dB Margin 50 Subranges</p>

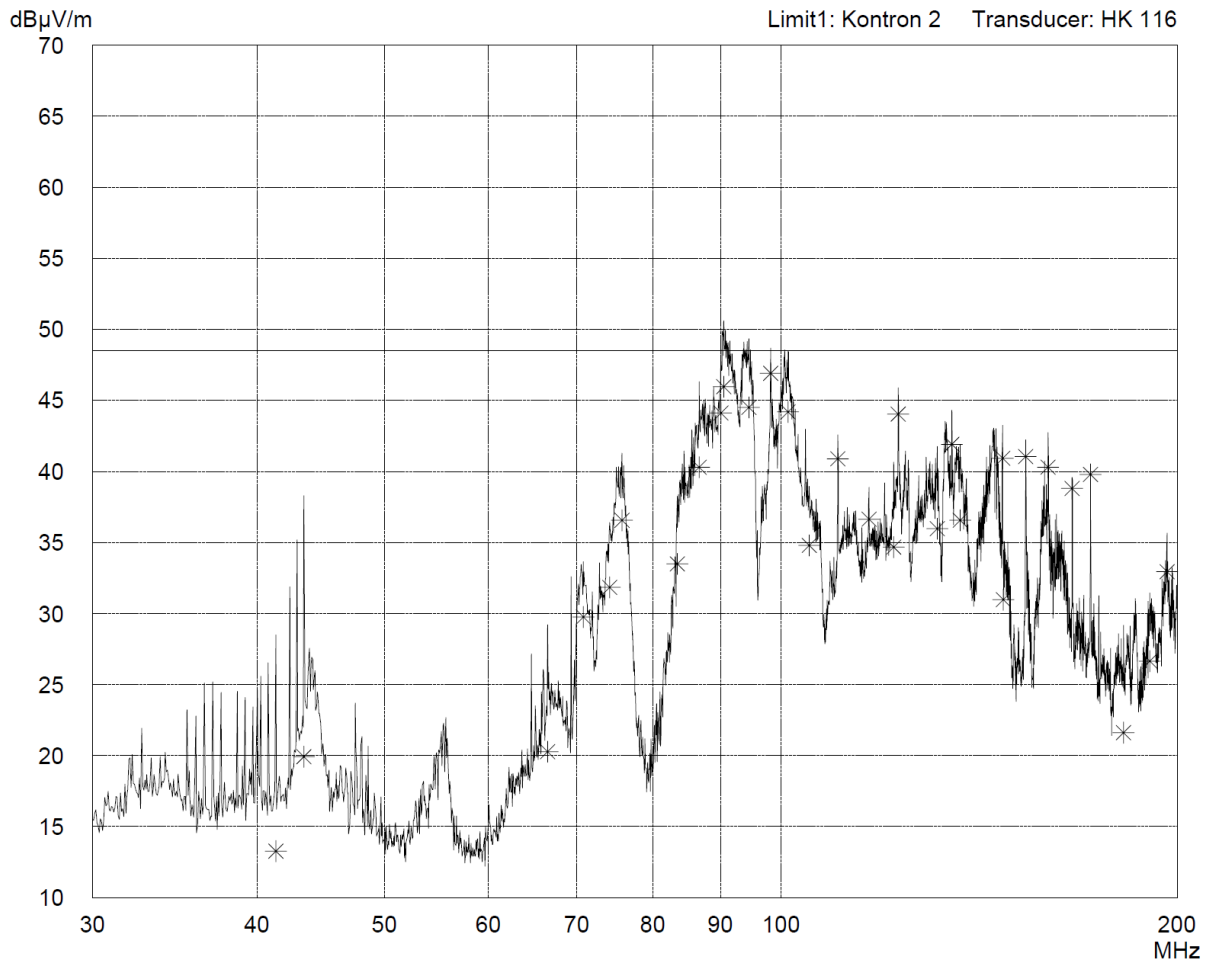

Radiated Emission Test 30 MHz - 200 MHz
acc. to KE_30MHz-200MHz

Model: KISS 2U 45-y	Comment: KISS 2U 45-y, 2-A0ED-2xxx
Serial no.: 001	PSU: Bicker R1S2-5380V4V AC red.
Applicant: Schiege K.	Accessories: PS/2 Keyboard and PS/2 Mouse, 23" DVI LCD Display and Headset
Test site: Shielded room PM-EM-6172-1	Connected data cables: VGA, COM1-2, LAN1-3 and USB1-8 (rear)
Tested on: Distance 1m Vertical Polarization	- BitPro v6.0 test SW: 2D Graphic H-Pattern test
Date of test: 03/11/2010	Operator: Vesely P.
Test performed: automatically	File name:
Detector: Peak / Final Results: QP	Final results: 20 dB Margin 50 Subranges

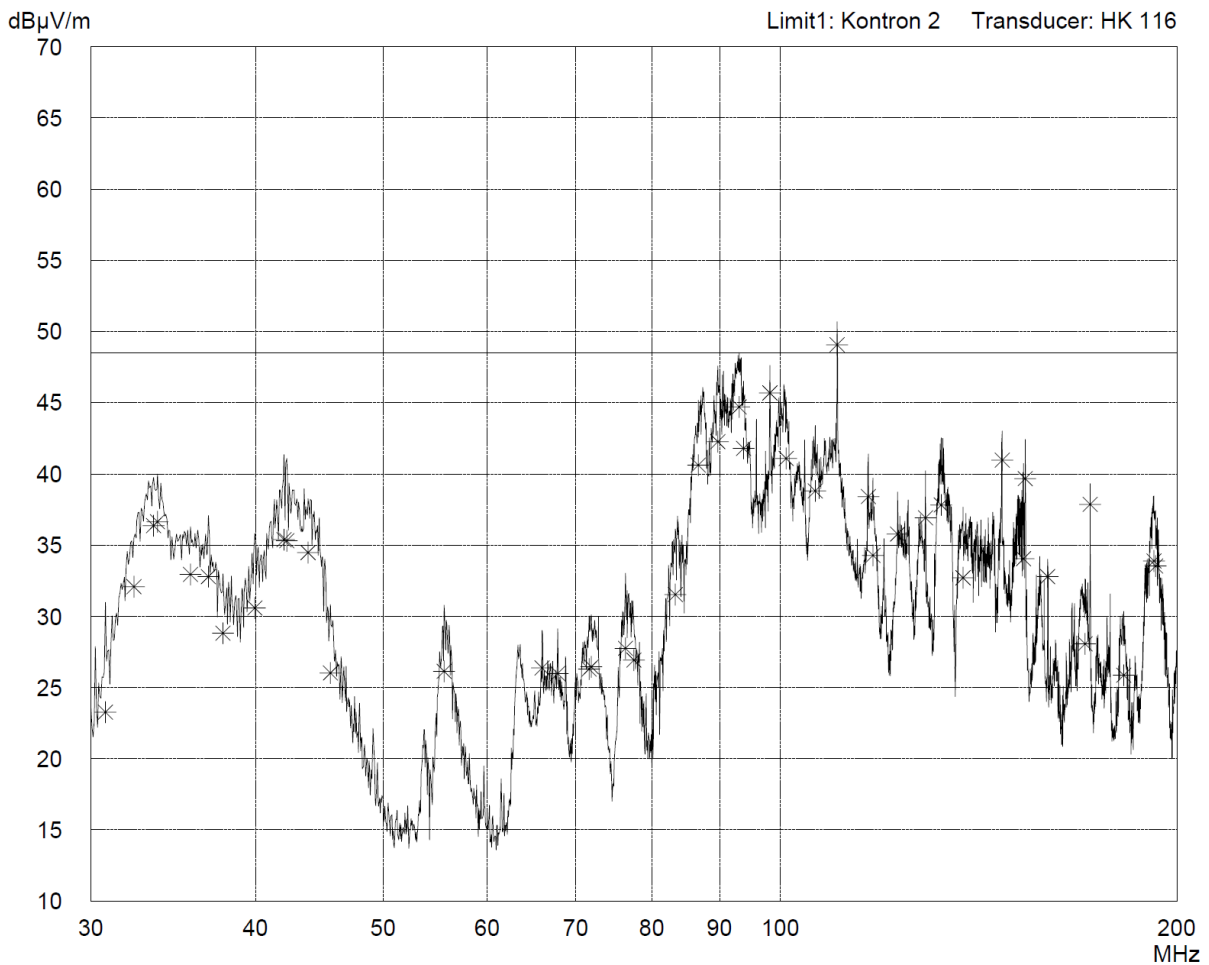

Radiated Emission Test 200 MHz - 1 GHz
acc. to KE_200MHz-2GHz

Model: KISS 2U 45-y	Comment: KISS 2U 45-y, 2-A0ED-2xxx
Serial no.: 001	PSU: Bicker R1S2-5380V4V AC red.
Applicant: Schiege K.	Accessories: PS/2 Keyboard and PS/2 Mouse, 23" DVI LCD Display and Headset
Test site: Shielded room PM-EM-6172-1	Connected data cables: VGA, COM1-2, LAN1-3 and USB1-8 (rear)
Tested on: Distance 1m Circular Polarization	- BitPro v6.0 test SW: 2D Graphic H-Pattern test - Display OFF - front side (0°)
Date of test: 03/11/2010	Operator: Vesely P.
Test performed: automatically	File name:
Detector: Peak / Final Results: QP	Final results: 20 dB Margin 50 Subranges

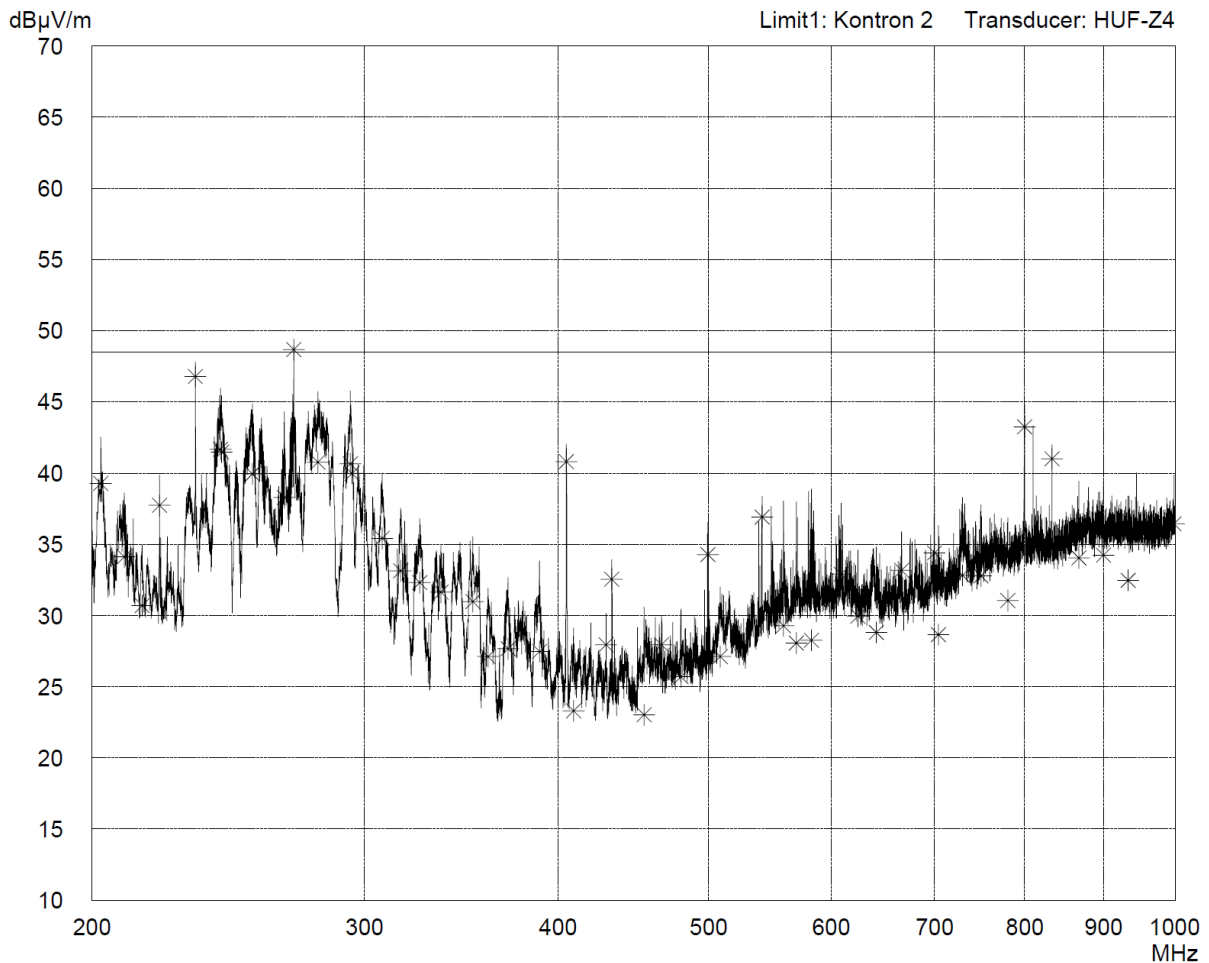

**Radiated Emission Test 30 MHz - 200 MHz
acc. to KE_30MHz-200MHz**

<p>Model: KISS 2U 45-y</p> <p>Serial no.: 001</p> <p>Applicant: Schiege K.</p> <p>Test site: Shielded room PM-EM-6172-1</p> <p>Tested on: Distance 1m Horizontal Polarization</p> <p>Date of test: 03/11/2010</p> <p>Test performed: automatically</p>	<p>Comment: KISS 2U 45-y, 2-A0ED-2xxx</p> <p>PSU: Bicker R1S2-5380V4V AC red.</p> <p>Accessories: PS/2 Keyboard and PS/2 Mouse, 23" DVI LCD Display and Headset</p> <p>Connected data cables: VGA, COM1-2, LAN1-3 and USB1-8 (rear)</p> <p>- BitPro v6.0 test SW: 2D Graphic H-Pattern test</p> <p>- Display OFF</p> <p>- interface side (180°)</p>
<p>Detector: Peak / Final Results: QP</p>	<p>Final results: 20 dB Margin 50 Subranges</p>

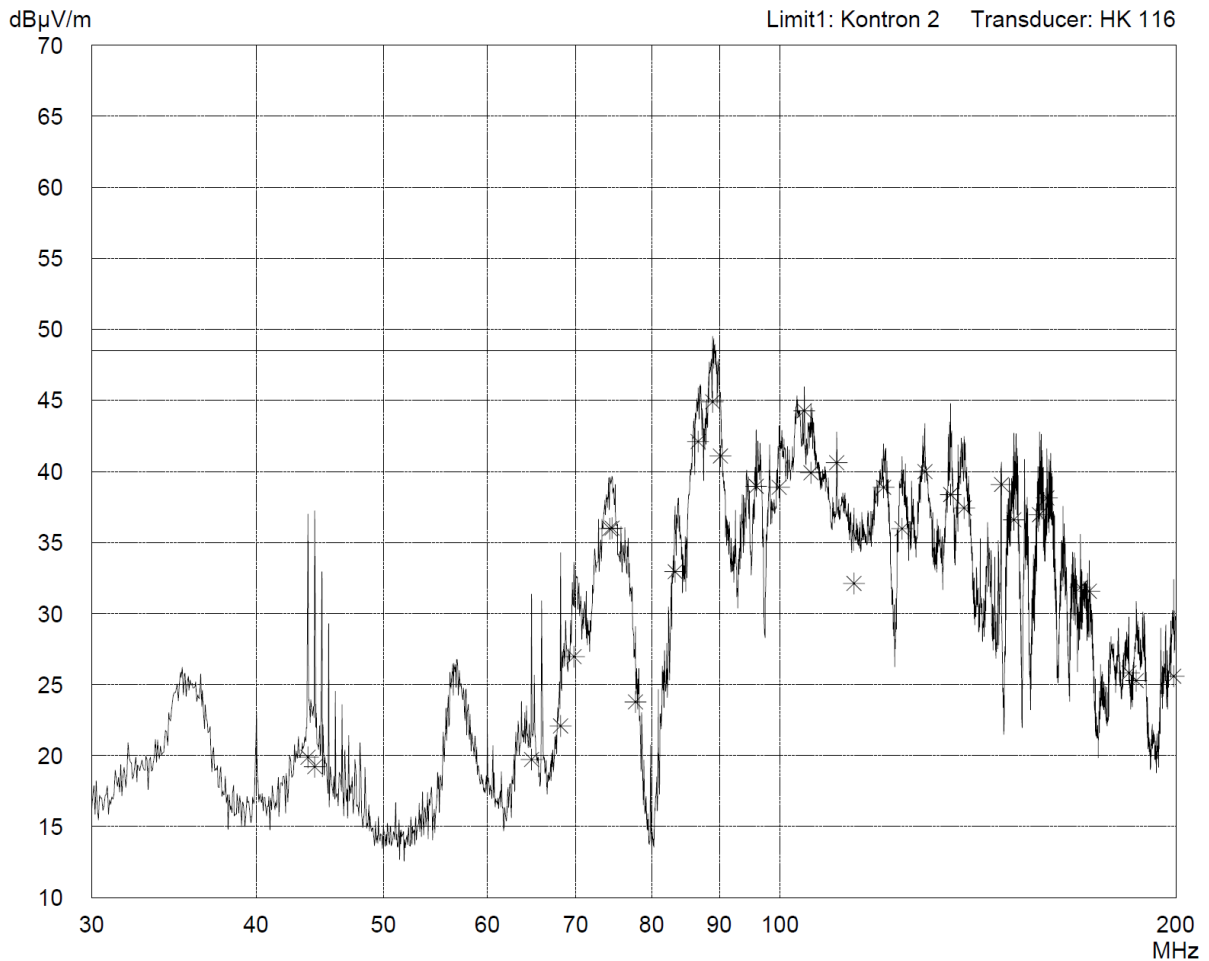

**Radiated Emission Test 30 MHz - 200 MHz
acc. to KE_30MHz-200MHz**

<p>Model: KISS 2U 45-y</p> <p>Serial no.: 001</p> <p>Applicant: Schiege K.</p> <p>Test site: Shielded room PM-EM-6172-1</p> <p>Tested on: Distance 1m Vertical Polarization</p> <p>Date of test: 03/11/2010</p> <p>Operator: Vesely P.</p> <p>Test performed: automatically</p> <p>File name:</p>	<p>Comment: KISS 2U 45-y, 2-A0ED-2xxx</p> <p>PSU: Bicker R1S2-5380V4V AC red.</p> <p>Accessories: PS/2 Keyboard and PS/2 Mouse, 23" DVI LCD Display and Headset</p> <p>Connected data cables: VGA, COM1-2, LAN1-3 and USB1-8 (rear)</p> <p>- BitPro v6.0 test SW: 2D Graphic H-Pattern test</p> <p>- Display OFF</p> <p>- interface side (180°)</p>
<p>Detector: Peak / Final Results: QP</p>	<p>Final results: 20 dB Margin 50 Subranges</p>

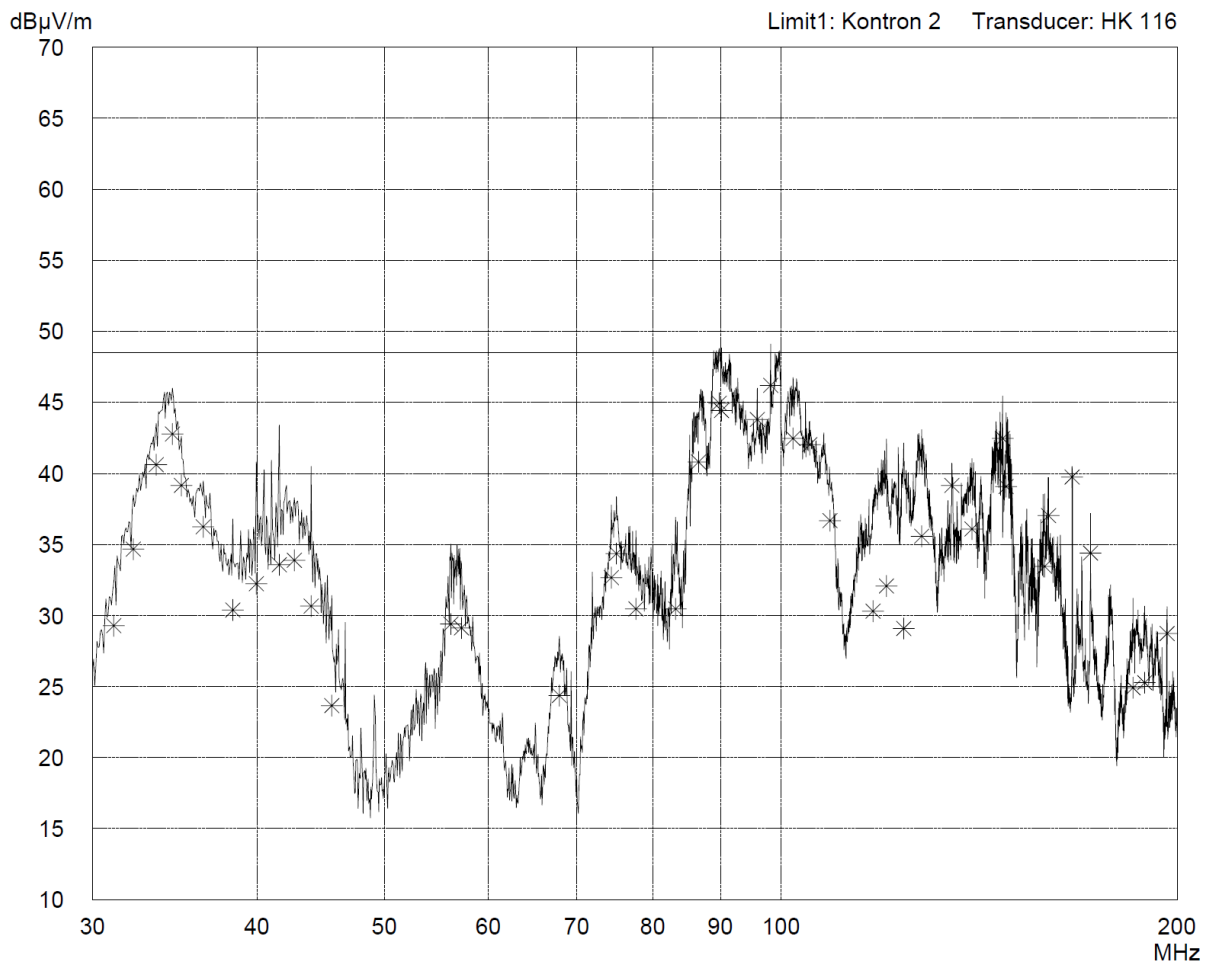

Radiated Emission Test 200 MHz - 1 GHz
acc. to KE_200MHz-2GHz

<p>Model: KISS 2U 45-y</p> <p>Serial no.: 001</p> <p>Applicant: Schiege K.</p> <p>Test site: Shielded room PM-EM-6172-1</p> <p>Tested on: Distance 1m Circular Polarization</p> <p>Date of test: 03/11/2010</p> <p>Test performed: automatically</p>	<p>Comment: KISS 2U 45-y, 2-A0ED-2xxx</p> <p>PSU: Bicker R1S2-5380V4V AC red.</p> <p>Accessories: PS/2 Keyboard and PS/2 Mouse, 23" DVI LCD Display and Headset</p> <p>Connected data cables: VGA, COM1-2, LAN1-3 and USB1-8 (rear)</p> <p>- BitPro v6.0 test SW: 2D Graphic H-Pattern test</p> <p>- Display OFF</p> <p>- interface side (180°)</p>
<p>Detector: Peak / Final Results: QP</p>	<p>Final results: 20 dB Margin 50 Subranges</p>

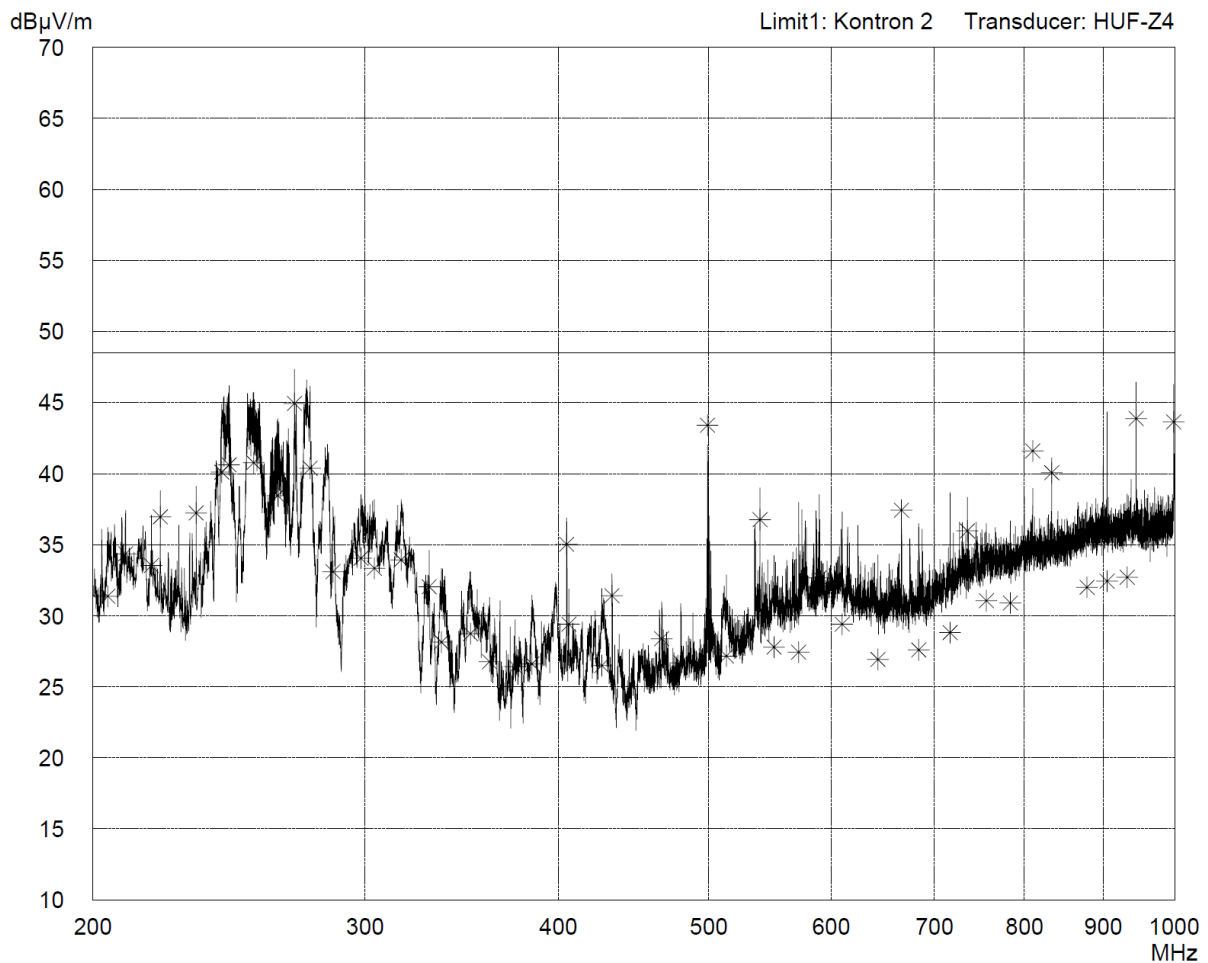

**Radiated Emission Test 30 MHz - 200 MHz
acc. to KE_30MHz-200MHz**

<p>Model: KISS 2U 45-y</p> <p>Serial no.: 001</p> <p>Applicant: Schiege K.</p> <p>Test site: Shielded room PM-EM-6172-1</p> <p>Tested on: Distance 1m Horizontal Polarization</p> <p>Date of test: 03/11/2010</p> <p>Test performed: automatically</p>	<p>Comment: KISS 2U 45-y, 2-A0ED-2xxx</p> <p>PSU: Bicker R1S2-5380V4V AC red.</p> <p>Accessories: PS/2 Keyboard and PS/2 Mouse, 23" DVI LCD Display and Headset</p> <p>Connected data cables: VGA, COM1-2, LAN1-3 and USB1-8 (rear)</p> <p>- BitPro v6.0 test SW: 2D Graphic H-Pattern test</p> <p>- Display OFF</p> <p>- left side (270°)</p>
<p>Detector: Peak / Final Results: QP</p>	<p>Final results: 20 dB Margin 50 Subranges</p>

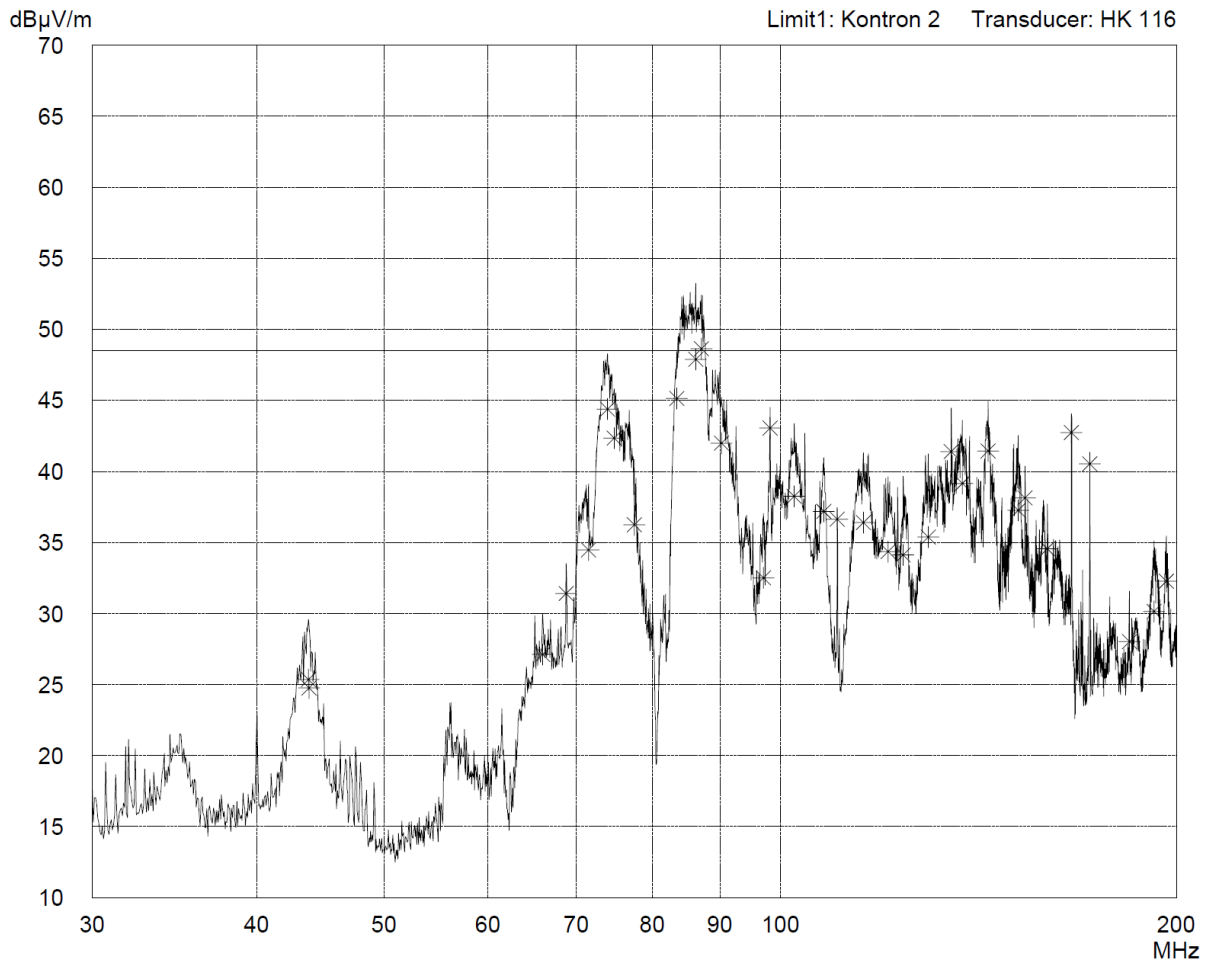

**Radiated Emission Test 30 MHz - 200 MHz
acc. to KE_30MHz-200MHz**

<p>Model: KISS 2U 45-y</p> <p>Serial no.: 001</p> <p>Applicant: Schiege K.</p> <p>Test site: Shielded room PM-EM-6172-1</p> <p>Tested on: Distance 1m Vertical Polarization</p> <p>Date of test: 03/11/2010</p> <p>Test performed: automatically</p>	<p>Comment: KISS 2U 45-y, 2-A0ED-2xxx</p> <p>PSU: Bicker R1S2-5380V4V AC red.</p> <p>Accessories: PS/2 Keyboard and PS/2 Mouse, 23" DVI LCD Display and Headset</p> <p>Connected data cables: VGA, COM1-2, LAN1-3 and USB1-8 (rear)</p> <p>- BitPro v6.0 test SW: 2D Graphic H-Pattern test</p> <p>- Display OFF</p> <p>- left side (270°)</p>
<p>Detector: Peak / Final Results: QP</p>	<p>Final results: 20 dB Margin 50 Subranges</p>

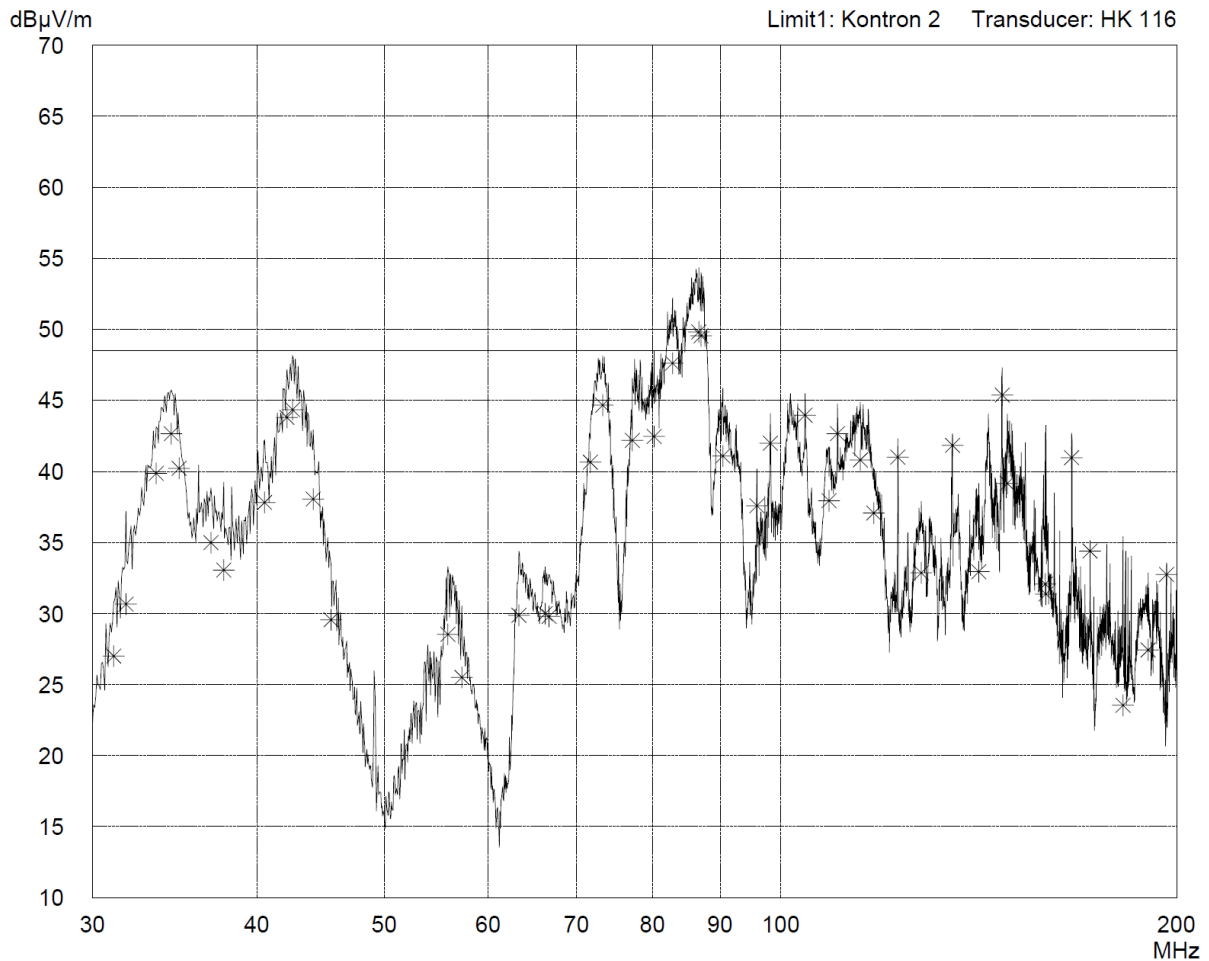

**Radiated Emission Test 200 MHz - 1 GHz
acc. to KE_200MHz-2GHz**

<p>Model: KISS 2U 45-y</p> <p>Serial no.: 001</p> <p>Applicant: Schiege K.</p> <p>Test site: Shielded room PM-EM-6172-1</p> <p>Tested on: Distance 1m Circular Polarization</p> <p>Date of test: 03/11/2010</p> <p>Test performed: automatically</p>	<p>Comment: KISS 2U 45-y, 2-A0ED-2xxx</p> <p>PSU: Bicker R1S2-5380V4V AC red.</p> <p>Accessories: PS/2 Keyboard and PS/2 Mouse, 23" DVI LCD Display and Headset</p> <p>Connected data cables: VGA, COM1-2, LAN1-3 and USB1-8 (rear)</p> <p>- BitPro v6.0 test SW: 2D Graphic H-Pattern test</p> <p>- Display OFF</p> <p>- left side (270°)</p>
<p>Detector: Peak / Final Results: QP</p>	<p>Final results: 20 dB Margin 50 Subranges</p>

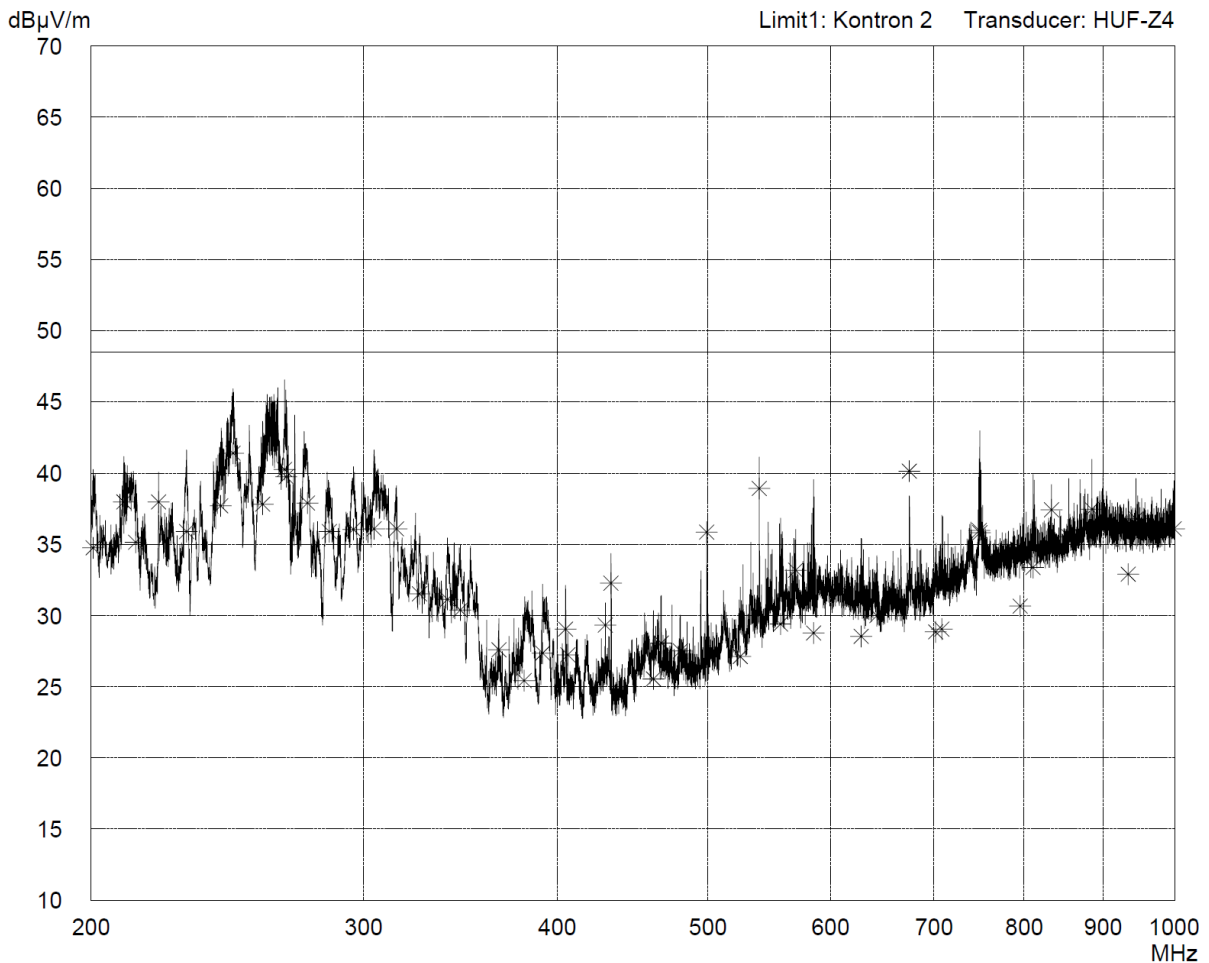

10.2 Test Report EN 61000-3-2

Limits for harmonic current emissions PSU1

(Equipment input current less than or equal to 16 A per phase) PowerFactorCorrector

Model:	KISS 2U 45-y
Applicant:	Kontron Embedded Computers GmbH
Operation mode:	Test software: see Point 4.1 (Operation Mode)
Regulation(s):	EN 61000-3-2: 2000 + A2: 2005
Requirements:	Harmonic n = 40; Unit: _Arms
Test result:	PASS
Classification:	The requirements are fulfilled
Date of test:	month: 01 day: 21 year: 2010
Tested by:	H. Novak

10.3 Test Report EN 61000-3-2

Limits for harmonic current emissions PSU3

(Equipment input current less than or equal to 16 A per phase) PowerFactorCorrector

Model:	KISS 2U 45-y
Applicant:	Kontron Embedded Computers GmbH
Operation mode:	Test software: see Point 4.1 (Operation Mode)
Regulation(s):	EN 61000-3-2: 2000 + A2: 2005
Requirements:	Harmonic n = 40; Unit: _Arms
Test result:	PASS
Classification:	The requirements are fulfilled
Date of test:	month: 01 day: 21 year: 2010
Tested by:	H. Novak

10.4 Test Report EN 61000-3-3

Limits for Voltage Fluctuation and Flicker PSU1

(Equipment input current less than or equal to 16 A per phase)

Model:	KISS 2U 45-y
Applicant:	Kontron Embedded Computers GmbH
Operation mode:	Test software: see Point 4.1 (Operation Mode)
Regulation(s):	EN 61000-3-3: 1995 + A1: 2001 + A2: 2005
Requirements:	Short-time flicker $P_{st} \leq 1$ (Observations 1x10 min) sliding $Plt \leq 0,65$; $dC \leq 3,3$ (%); $d_{max} \leq 4$ (%); $d(t) > 3,3\%$ (Sec)
Test result:	PASS
Classification:	The requirements are fulfilled.
Date of test:	month: 01 day: 21 year: 2010
Tested by:	H. Novak

10.5 Test Report EN 61000-3-3

Limits for Voltage Fluctuation and Flicker PSU3

(Equipment input current less than or equal to 16 A per phase)

Model:	KISS 2U 45-y
Applicant:	Kontron Embedded Computers GmbH
Operation mode:	Test software: see Point 4.1 (Operation Mode)
Regulation(s):	EN 61000-3-3: 1995 + A1: 2001 + A2: 2005
Requirements:	Short-time flicker $P_{st} \leq 1$ (Observations 1x10 min) sliding $Plt \leq 0,65$; $dC \leq 3,3$ (%); $d_{max} \leq 4$ (%); $d(t) > 3,3\%$ (Sec)
Test result:	PASS
Classification:	The requirements are fulfilled.
Date of test:	month: 01 day: 21 year: 2010
Tested by:	H. Novak

10.6 Test Report EN 61000-4-2

Electrostatic Discharge Immunity test – Indirect action

Model:	KISS 2U 45-y																	
Applicant:	Kontron Embedded Computers GmbH																	
Operation mode:	Test software: see Point 4.1 (Operation Mode)																	
Regulation(s):	EN 61000-4-2: 1995 + A1: 1998 + A2: 2001																	
Performed test:	Contact discharge								Air discharge									
Locations of discharge:	Several points close to EUT at horizontal coupling plate																	
Tested severity level/ voltage:	-	1	2	3	4	5	6	7	8	9	10	11	12	13	14	15	16	kV
	+	1	2	3	4	5	6	7	8	9	10	11	12	13	14	15	16	kV
Locations of discharge:	Several points close to EUT at vertical coupling plate																	
Tested severity level/ voltage:	-	1	2	3	4	5	6	7	8	9	10	11	12	13	14	15	16	kV
	+	1	2	3	4	5	6	7	8	9	10	11	12	13	14	15	16	kV
Performance criteria:	Temporary degradation or loss of function or performance (criterion B)																	
Test result:	No errors detected.																	
Classification:	The requirements are fulfilled.																	
Date of test:	month: 01					day: 26					year: 2010							
Tested by:	H. Novak																	

1 tested

1 not tested

10.7 Test Report EN 61000-4-2

Electrostatic Discharge Immunity test – Direct action

Model:	KISS 2U 45-y										
Applicant:	Kontron Embedded Computers GmbH										
Operation mode:	Test software: see Point 4.1 (Operation Mode)										
Regulation(s):	EN 61000-4-2: 1995 + A1: 1998 + A2: 2001										
Performed test:	Contact discharge						Air discharge				
Locations of discharge:	Whole surface of the EUT										
Tested severity level/ voltage:	-	1	2	3	4	5	6	7	8		kV
	+	1	2	3	4	5	6	7	8		kV
Locations of discharge:	All conductive parts of EUT accessible to normal user										
Tested severity level/ voltage:	-	1	2	3	4	5	6	7	8		kV
	+	1	2	3	4	5	6	7	8		kV
Performance criteria:	Temporary degradation or loss of function or performance (criterion B)										
Test result:	No errors detected.										
Classification:	The requirements are fulfilled.										
Date of test:	month:	01	day:	26	year:	2010					
Tested by:	H. Novak										

1 tested

1 not tested

10.8 Test Report EN 61000-4-4 Electrical Fast Transients Burst Immunity test - Power Lines (Coupling Filter) PSU1

Model:	KISS 2U 45-y								
Applicant:	Kontron Embedded Computers GmbH								
Operation mode:	Test software: see Point 4.1 (Operation Mode)								
Regulation(s):	EN 61000-4-4: 2004								
Performed test:	Capacitive coupling with coupling/decoupling network								
Coupling via:	Coupling filter								
Coupling to:	Power Line: L								
Tested severity level/	+		0.5	1.0	2.0	4.0		kV	
pulse amplitude:	-		0.5	1.0	2.0	4.0		kV	
Coupling to:	Power Line: N								
Tested severity level/	+		0.5	1.0	2.0	4.0		kV	
pulse amplitude:	-		0.5	1.0	2.0	4.0		kV	
Coupling to:	Power Line: PE								
Tested severity level/	+		0.5	1.0	2.0	4.0		kV	
pulse amplitude	-		0.5	1.0	2.0	4.0		kV	
Coupling to:	Power Line: L, N, PE								
Tested severity level/	+		0.5	1.0	2.0	4.0		kV	
pulse amplitude:	-		0.5	1.0	2.0	4.0		kV	
Performance criteria:	Temporary degradation or loss of function or performance (criterion B)								
Test result:	No inadmissible errors detected.								
Classification:	The requirements are fulfilled.								
Date of test:	month:	01	day:	27	year:	2010			
Tested by:	P. Vesely								
1	tested	1	not tested						

10.9 Test Report EN 61000-4-4 Electrical Fast Transients Burst Immunity test - Power Lines (Coupling Filter) PSU2

Model:	KISS 2U 45-y								
Applicant:	Kontron Embedded Computers GmbH								
Operation mode:	Test software: see Point 4.1 (Operation Mode)								
Regulation(s):	EN 61000-4-4: 2004								
Performed test:	Capacitive coupling with coupling/decoupling network								
Coupling via:	Coupling filter								
Coupling to:	Power Line: L+								
Tested severity level/	+		0.5	1.0	2.0	4.0		kV	
pulse amplitude:	-		0.5	1.0	2.0	4.0		kV	
Coupling to:	Power Line: L-								
Tested severity level/	+		0.5	1.0	2.0	4.0		kV	
pulse amplitude:	-		0.5	1.0	2.0	4.0		kV	
Coupling to:	Power Line:								
Tested severity level/	+		0.5	1.0	2.0	4.0		kV	
pulse amplitude	-		0.5	1.0	2.0	4.0		kV	
Coupling to:	Power Line:								
Tested severity level/	+		0.5	1.0	2.0	4.0		kV	
pulse amplitude:	-		0.5	1.0	2.0	4.0		kV	
Performance criteria:	Temporary degradation or loss of function or performance (criterion B)								
Test result:	No inadmissible errors detected.								
Classification:	The requirements are fulfilled.								
Date of test:	month: 01		day: 27		year: 2010				
Tested by:	P. Vesely								
1	tested	1	not tested						

10.10 Test Report EN 61000-4-4 Electrical Fast Transients Burst Immunity test - Power Lines (Coupling Filter) PSU3

Model:	KISS 2U 45-y							
Applicant:	Kontron Embedded Computers GmbH							
Operation mode:	Test software: see Point 4.1 (Operation Mode)							
Regulation(s):	EN 61000-4-4: 2004							
Performed test:	Capacitive coupling with coupling/decoupling network							
Coupling via:	Coupling filter							
Coupling to:	Power Line: L							
Tested severity level/ pulse amplitude:	+		0.5	1.0	2.0	4.0		kV
	-		0.5	1.0	2.0	4.0		kV
Coupling to:	Power Line: N							
Tested severity level/ pulse amplitude:	+		0.5	1.0	2.0	4.0		kV
	-		0.5	1.0	2.0	4.0		kV
Coupling to:	Power Line: PE							
Tested severity level/ pulse amplitude:	+		0.5	1.0	2.0	4.0		kV
	-		0.5	1.0	2.0	4.0		kV
Coupling to:	Power Line: L, N, PE							
Tested severity level/ pulse amplitude:	+		0.5	1.0	2.0	4.0		kV
	-		0.5	1.0	2.0	4.0		kV
Performance criteria:	Temporary degradation or loss of function or performance (criterion B)							
Test result:	No inadmissible errors detected.							
Classification:	The requirements are fulfilled.							
Date of test:	month: 01		day: 27		year: 2010			
Tested by:	P. Vesely							
1	tested		1	not tested				

10.11 Test Report EN 61000-4-4

Electrical Fast Transients/Burst Immunity test - Data Lines (Coupling Clamp)

Model:	KISS 2U 45-y								
Applicant:	Kontron Embedded Computers GmbH								
Operation mode:	Test software: see Point 4.1 (Operation Mode)								
Regulation(s):	EN 61000-4-4: 2004								
Performed test:	Capacitive coupling with capacitive coupling clamp								
Coupling via:	Capacitive coupling clamp								
Coupling to:	PSU1 ÷ PSU3 Data Lines: LAN1 ÷ 3, COM1+2, DVI (VGA) and USB1-8 Test Cables								
Tested severity level/ pulse amplitude:	+	0.25	0.5	1.0	2.0	4.0		kV	
	-	0.25	0.5	1.0	2.0	4.0		kV	
Coupling to:									
Tested severity level/ pulse amplitude:	+	0.25	0.5	1.0	2.0	4.0		kV	
	-	0.25	0.5	1.0	2.0	4.0		kV	
Coupling to:									
Tested severity level/ pulse amplitude:	+	0.25	0.5	1.0	2.0	4.0		kV	
	-	0.25	0.5	1.0	2.0	4.0		kV	
Performance criteria:	Temporary degradation or loss of function or performance (criterion B)								
Test result:	No errors detected.								
Classification:	The requirements are fulfilled.								
Date of test:	month:	01	day:	27	year:	2010			
Tested by:	P. Vesely								
1 tested			1 not tested						

10.12 Test Report EN 61000-4-5

Surge Immunity test - Power Lines PSU1

Model:	KISS 2U 45-y							
Applicant:	Kontron Embedded Computers GmbH							
Operation mode:	Test software: see Point 4.1 (Operation Mode)							
Regulation(s):	EN 61000-4-5: 2006							
Performed test:	Capacitive coupling with coupling/decoupling network							
Coupling to:	Symmetrical coupling between L1 and L2							
Tested severity level/ pulse amplitude:	+		0.5	1.0	2.0	4.0		kV
	-		0.5	1.0	2.0	4.0		kV
Coupling to:	Asymmetrical coupling onto L1							
Tested severity level/ pulse amplitude:	+		0.5	1.0	2.0	4.0		kV
	-		0.5	1.0	2.0	4.0		kV
Coupling to:	Asymmetrical coupling onto L2							
Tested severity level/ pulse amplitude:	+		0.5	1.0	2.0	4.0		kV
	-		0.5	1.0	2.0	4.0		kV
Performance criteria:	Temporary degradation or loss of function or performance (criterion B)							
Test result:	No inadmissible errors detected.							
Classification:	The requirements are fulfilled.							
Date of test:	month: 01		day: 28		year: 2010			
Tested by:	H. Novak							

 1 tested

 1 not tested

10.13 Test Report EN 61000-4-5

Surge Immunity test - Power Lines PSU2

Model:	KISS 2U 45-y							
Applicant:	Kontron Embedded Computers GmbH							
Operation mode:	Test software: see Point 4.1 (Operation Mode)							
Regulation(s):	EN 61000-4-5: 2006							
Performed test:	Capacitive coupling with coupling/decoupling network							
Coupling to:	Symmetrical coupling between L+ and L-							
Tested severity level/ pulse amplitude:	+		0.5	1.0	2.0	4.0		kV
	-		0.5	1.0	2.0	4.0		kV
Coupling to:	Asymmetrical coupling onto L+							
Tested severity level/ pulse amplitude:	+		0.5	1.0	2.0	4.0		kV
	-		0.5	1.0	2.0	4.0		kV
Coupling to:	Asymmetrical coupling onto L-							
Tested severity level/ pulse amplitude:	+		0.5	1.0	2.0	4.0		kV
	-		0.5	1.0	2.0	4.0		kV
Performance criteria:	Temporary degradation or loss of function or performance (criterion B)							
Test result:	No inadmissible errors detected.							
Classification:	The requirements are fulfilled.							
Date of test:	month: 01		day: 28		year: 2010			
Tested by:	H. Novak							

1 tested

1 not tested

10.14 Test Report EN 61000-4-5

Surge Immunity test - Power Lines PSU3

Model:	KISS 2U 45-y							
Applicant:	Kontron Embedded Computers GmbH							
Operation mode:	Test software: see Point 4.1 (Operation Mode)							
Regulation(s):	EN 61000-4-5: 2006							
Performed test:	Capacitive coupling with coupling/decoupling network							
Coupling to:	Symmetrical coupling between L1 and L2							
Tested severity level/ pulse amplitude:	+		0.5	1.0	2.0	4.0		kV
	-		0.5	1.0	2.0	4.0		kV
Coupling to:	Asymmetrical coupling onto L1							
Tested severity level/ pulse amplitude:	+		0.5	1.0	2.0	4.0		kV
	-		0.5	1.0	2.0	4.0		kV
Coupling to:	Asymmetrical coupling onto L2							
Tested severity level/ pulse amplitude:	+		0.5	1.0	2.0	4.0		kV
	-		0.5	1.0	2.0	4.0		kV
Performance criteria:	Temporary degradation or loss of function or performance (criterion B)							
Test result:	No inadmissible errors detected.							
Classification:	The requirements are fulfilled.							
Date of test:	month: 01		day: 28		year: 2010			
Tested by:	H. Novak							

1 tested

1 not tested

10.15 Test Report EN 61000-4-5

Surge Immunity test - Shielded Data Lines

Model:	KISS 2U 45-y							
Applicant:	Kontron Embedded Computers GmbH							
Operation mode:	Test software: see Point 4.1 (Operation Mode)							
Regulation(s):	EN 61000-4-5: 2006							
Performed test:	Coupling direct onto shield							
Coupling to:	Data Line: Coupling onto LAN1 ÷ 3 Test Cables							
Tested severity level/ pulse amplitude:	+	0.25	0.5	1.0	2.0	4.0		kV
	-	0.25	0.5	1.0	2.0	4.0		kV
Coupling to:	Data Line: Coupling onto COM1 + 2 Test Cables							
Tested severity level/ pulse amplitude:	+	0.25	0.5	1.0	2.0	4.0		kV
	-	0.25	0.5	1.0	2.0	4.0		kV
Coupling to:	Data Line:							
Tested severity level/ pulse amplitude:	+	0.25	0.5	1.0	2.0	4.0		kV
	-	0.25	0.5	1.0	2.0	4.0		kV
Coupling to:	Data Line:							
Tested severity level/ pulse amplitude:	+	0.25	0.5	1.0	2.0	4.0		kV
	-	0.25	0.5	1.0	2.0	4.0		kV
Performance criteria:	Temporary degradation or loss of function or performance (criterion B).							
Test result:	No inadmissible errors detected.							
Classification:	The requirements are fulfilled.							
Date of test:	month: 01	day: 28	year: 2010					
Tested by:	H. Novak							

 1 tested

 1 not tested

10.16 Test Report EN 61000-4-6

Immunity to Conducted Disturbances Induced by RF Fields – Power Lines PSU1

Model:	KISS 2U 45-y
Applicant:	Kontron Embedded Computers GmbH
Operation mode:	Test software: see Point 4.1 (Operation Mode)
Regulation(s):	EN 61000-4-6: 1996 + A1: 2001
Requirements:	150 kHz to 230 MHz : 10 V _{eff}
Interfering signal:	Modulation: AM Modulation depth: 80 % Modulation frequency: 1 kHz Step size: 1 % Dwell time: 1 s
Coupling to:	Power cables
Coupling with:	CDN: FCC-M3; S/N: 9720; PM-EM-7544-1
Performance criteria:	No temporary degradation or loss of function or performance (criterion A)
Test result:	No errors detected.
Classification:	The requirements are fulfilled.
Date of test:	month: 01 day: 29 year: 2010
Tested by:	H. Novak

10.17 Test Report EN 61000-4-6

Immunity to Conducted Disturbances Induced by RF Fields – Power Lines PSU2

Model:	KISS 2U 45-y
Applicant:	Kontron Embedded Computers GmbH
Operation mode:	Test software: see Point 4.1 (Operation Mode)
Regulation(s):	EN 61000-4-6: 1996 + A1: 2001
Requirements:	150 kHz to 230 MHz : 10 V _{eff}
Interfering signal:	Modulation: AM Modulation depth: 80 % Modulation frequency: 1 kHz Step size: 1 % Dwell time: 1 s
Coupling to:	Power cables
Coupling with:	CDN: FCC-M2, S/N: 9712, PM-EM-7543-1
Performance criteria:	No temporary degradation or loss of function or performance (criterion A)
Test result:	No errors detected.
Classification:	The requirements are fulfilled.
Date of test:	month: 01 day: 29 year: 2010
Tested by:	H. Novak

10.18 Test Report EN 61000-4-6

Immunity to Conducted Disturbances Induced by RF Fields – Power Lines PSU3

Model:	KISS 2U 45-y
Applicant:	Kontron Embedded Computers GmbH
Operation mode:	Test software: see Point 4.1 (Operation Mode)
Regulation(s):	EN 61000-4-6: 1996 + A1: 2001
Requirements:	150 kHz to 230 MHz : 10 V _{eff}
Interfering signal:	Modulation: AM Modulation depth: 80 % Modulation frequency: 1 kHz Step size: 1 % Dwell time: 1 s
Coupling to:	Power cables
Coupling with:	CDN: FCC-M3; S/N: 9720; PM-EM-7544-1
Performance criteria:	No temporary degradation or loss of function or performance (criterion A)
Test result:	No errors detected.
Classification:	The requirements are fulfilled.
Date of test:	month: 01 day: 29 year: 2010
Tested by:	H. Novak

10.19 Test Report EN 61000-4-6

Immunity to Conducted Disturbances Induced by RF Fields – Data Lines

Model:	KISS 2U 45-y
Applicant:	Kontron Embedded Computers GmbH
Operation mode:	Test software: see Point 4.1 (Operation Mode)
Regulation(s):	EN 61000-4-6: 1996 + A1: 2001
Requirements:	150 kHz to 230 MHz : 10 V _{eff}
Interfering signal:	Modulation: AM Modulation depth: 80 % Modulation frequency: 1 kHz Step size: 1 % Dwell time: 1 s
Coupling to:	LAN1-3, COM1+2, DVI (VGA) and USB1-8 Test Cables
Coupling with:	F 120-9A; S/N: 20; PM-EM-7546-1
Performance criteria:	No temporary degradation or loss of function or performance (criterion A)
Test result:	No errors detected.
Classification:	The requirements are fulfilled.
Date of test:	month: 01 day: 29 year: 2010
Tested by:	H. Novak

10.20 Test Report EN 61000-4-8

Power Frequency Magnetic Field Immunity Test

Model:	KISS 2U 45-y
Applicant:	Kontron Embedded Computers GmbH
Operation mode:	Test software: see Point 4.1 (Operation Mode)
Regulation(s):	EN 61000-4-8: 1993 + A1: 2001
Requirements:	50 Hz; 30 A/m
Performance criteria:	No temporary degradation or loss of function or performance (criterion A)
Test result:	No errors detected.
Classification:	The requirements are fulfilled.
Date of test:	month: 01 day: 21 year: 2010
Tested by:	H. Novak

10.21 Test Report EN 61000-4-11

Voltage Dips, Short Interruptions and Voltage Variations

Immunity Tests PSU1

Model:	KISS 2U 45-y
Applicant:	Kontron Embedded Computers GmbH
Operation mode:	Test software: see Point 4.1 (Operation Mode)
Regulation(s):	EN 61000-4-11: 2004
Requirements:	AC input: 100 % - 10ms reduction
Performance criteria:	Temporary degradation or loss of function or performance (criterion C).
Test result:	No errors detected.
Classification:	The requirements are fulfilled.
Date of test:	month: 01 day: 21 year: 2010
Tested by:	H. Novak

10.22 Test Report EN 61000-4-11

Voltage Dips, Short Interruptions and Voltage Variations Immunity Tests PSU1

Model:	KISS 2U 45-y
Applicant:	Kontron Embedded Computers GmbH
Operation mode:	Test software: see Point 4.1 (Operation Mode)
Regulation(s):	EN 61000-4-11: 2004
Requirements:	AC input: 100 % - 20ms reduction
Performance criteria:	Temporary degradation or loss of function or performance (criterion C).
Test result:	No errors detected.
Classification:	The requirements are fulfilled.
Date of test:	month: 01 day: 21 year: 2010
Tested by:	H. Novak

10.23 Test Report EN 61000-4-11

Voltage Dips, Short Interruptions and Voltage Variations Immunity Tests PSU1

Model:	KISS 2U 45-y
Applicant:	Kontron Embedded Computers GmbH
Operation mode:	Test software: see Point 4.1 (Operation Mode)
Regulation(s):	EN 61000-4-11: 2004
Requirements:	AC input: 60 % - 0,2s reduction
Performance criteria:	Temporary degradation or loss of function or performance (criterion C).
Test result:	No inadmissible errors detected.
Classification:	The requirements are fulfilled.
Date of test:	month: 01 day: 21 year: 2010
Tested by:	H. Novak

10.24 Test Report EN 61000-4-11

Voltage Dips, Short Interruptions and Voltage Variations Immunity Tests PSU1

Model:	KISS 2U 45-y
Applicant:	Kontron Embedded Computers GmbH
Operation mode:	Test software: see Point 4.1 (Operation Mode)
Regulation(s):	EN 61000-4-11: 2004
Requirements:	AC input: 30 % - 0,5s reduction
Performance criteria:	Temporary degradation or loss of function or performance (criterion C).
Test result:	No errors detected.
Classification:	The requirements are fulfilled.
Date of test:	month: 01 day: 21 year: 2010
Tested by:	H. Novak

10.25 Test Report EN 61000-4-11

Voltage Dips, Short Interruptions and Voltage Variations Immunity Tests PSU1

Model:	KISS 2U 45-y
Applicant:	Kontron Embedded Computers GmbH
Operation mode:	Test software: see Point 4.1 (Operation Mode)
Regulation(s):	EN 61000-4-11: 2004
Requirements:	AC input: 20 % - 5s reduction
Performance criteria:	Temporary degradation or loss of function or performance (criterion C).
Test result:	No errors detected.
Classification:	The requirements are fulfilled.
Date of test:	month: 01 day: 21 year: 2010
Tested by:	H. Novak

10.26 Test Report EN 61000-4-11

Voltage Dips, Short Interruptions and Voltage Variations

Immunity Tests PSU1

Model:	KISS 2U 45-y
Applicant:	Kontron Embedded Computers GmbH
Operation mode:	Test software: see Point 4.1 (Operation Mode)
Regulation(s):	EN 61000-4-11: 2004
Requirements:	AC input: 100 % - 5000ms reduction
Performance criteria:	Temporary degradation or loss of function or performance (criterion C).
Test result:	No inadmissible errors detected.
Classification:	The requirements are fulfilled.
Date of test:	month: 01 day: 21 year: 2010
Tested by:	H. Novak

10.27 Test Report EN 61000-4-11

Voltage Dips, Short Interruptions and Voltage Variations Immunity Tests PSU3

Model:	KISS 2U 45-y
Applicant:	Kontron Embedded Computers GmbH
Operation mode:	Test software: see Point 4.1 (Operation Mode)
Regulation(s):	EN 61000-4-11: 2004
Requirements:	AC input: 100 % - 10ms reduction
Performance criteria:	Temporary degradation or loss of function or performance (criterion C).
Test result:	No errors detected.
Classification:	The requirements are fulfilled.
Date of test:	month: 01 day: 21 year: 2010
Tested by:	H. Novak

10.28 Test Report EN 61000-4-11

Voltage Dips, Short Interruptions and Voltage Variations Immunity Tests PSU3

Model:	KISS 2U 45-y
Applicant:	Kontron Embedded Computers GmbH
Operation mode:	Test software: see Point 4.1 (Operation Mode)
Regulation(s):	EN 61000-4-11: 2004
Requirements:	AC input: 100 % - 20ms reduction
Performance criteria:	Temporary degradation or loss of function or performance (criterion C).
Test result:	No errors detected.
Classification:	The requirements are fulfilled.
Date of test:	month: 01 day: 21 year: 2010
Tested by:	H. Novak

10.29 Test Report EN 61000-4-11

Voltage Dips, Short Interruptions and Voltage Variations Immunity Tests PSU3

Model:	KISS 2U 45-y
Applicant:	Kontron Embedded Computers GmbH
Operation mode:	Test software: see Point 4.1 (Operation Mode)
Regulation(s):	EN 61000-4-11: 2004
Requirements:	AC input: 60 % - 0,2s reduction
Performance criteria:	Temporary degradation or loss of function or performance (criterion C).
Test result:	No inadmissible errors detected.
Classification:	The requirements are fulfilled.
Date of test:	month: 01 day: 21 year: 2010
Tested by:	H. Novak

10.30 Test Report EN 61000-4-11

Voltage Dips, Short Interruptions and Voltage Variations Immunity Tests PSU3

Model:	KISS 2U 45-y
Applicant:	Kontron Embedded Computers GmbH
Operation mode:	Test software: see Point 4.1 (Operation Mode)
Regulation(s):	EN 61000-4-11: 2004
Requirements:	AC input: 30 % - 0,5s reduction
Performance criteria:	Temporary degradation or loss of function or performance (criterion C).
Test result:	No errors detected.
Classification:	The requirements are fulfilled.
Date of test:	month: 01 day: 21 year: 2010
Tested by:	H. Novak

10.31 Test Report EN 61000-4-11

Voltage Dips, Short Interruptions and Voltage Variations Immunity Tests PSU3

Model:	KISS 2U 45-y
Applicant:	Kontron Embedded Computers GmbH
Operation mode:	Test software: see Point 4.1 (Operation Mode)
Regulation(s):	EN 61000-4-11: 2004
Requirements:	AC input: 20 % - 5s reduction
Performance criteria:	Temporary degradation or loss of function or performance (criterion C).
Test result:	No errors detected.
Classification:	The requirements are fulfilled.
Date of test:	month: 01 day: 21 year: 2010
Tested by:	H. Novak

10.32 Test Report EN 61000-4-11

Voltage Dips, Short Interruptions and Voltage Variations Immunity Tests PSU3

Model:	KISS 2U 45-y
Applicant:	Kontron Embedded Computers GmbH
Operation mode:	Test software: see Point 4.1 (Operation Mode)
Regulation(s):	EN 61000-4-11: 2004
Requirements:	AC input: 100 % - 5000ms reduction
Performance criteria:	Temporary degradation or loss of function or performance (criterion C).
Test result:	No inadmissible errors detected.
Classification:	The requirements are fulfilled.
Date of test:	month: 01 day: 21 year: 2010
Tested by:	H. Novak

11. Measurement Uncertainty Values:

11.1 Emission Testing

Used measuring instrument	Unit	Tolerance
Test Receiver ESMI		< 1,5dB
LISN ESH3-Z5		$\leq \pm 20\%$
LISN ESH3-Z6		$\leq \pm 20\%$
LISN ENV4200		$\leq \pm 20\%$
Pulse Limiter ESH3-Z3		$\leq \pm 0,2\text{dB}$
Cable attenuation incl. PSU		
10kHz - 30MHz		$\leq \pm 0,5\text{dB}$
30MHz - 200MHz		$\leq \pm 1,5\text{dB}$
200MHz - 1GHz		$\leq \pm 2,7\text{dB}$
Pre Amplifier ESMI-Z7		max. + 2dB/-1dB
Current Clamp -ESH2-Z1	uA	$\leq \pm 1\text{dB}$
Current Clamp -ESV-Z1	uA	$\leq \pm 0,5\text{dB}$
Current Clamp -F61	uA	$\leq \pm 1,8\text{dB}$
Current Clamp F-65A	uA	$\leq \pm 1,8\text{dB}$
Current Clamp F-36-4	uA	$\leq \pm 1,8\text{dB}$
Current Clamp F-2000	uA	$\leq \pm 1,8\text{dB}$

11.2 Immunity Testing

Used measuring instrument	Unit	Tolerance
Harmonics current PHE5000/PAS	Measured current	$\pm 1 \%$
Flicker PHE5000/PAS	Higher than specified by IEC868 + AMD 1	
PHE5000/PAS	Adjusted voltage	$\pm 1 \%$
ESD generator NSG 435	Air discharge	$\pm 5 \%$
	Contact discharge	$\pm 5 \%$
Burst generator NSG 2025	Test level voltage	$\pm 10 \%$
	Frequency	$\pm 2 \%$
	Phase angle	$\pm 2^\circ$
	Pulse rise time:	
	BNC output below 1500V	$\pm 30 \%$
	BNC output above 1500V	$\pm 20 \%$
	Mains output	$\pm 30 \%$
Pulse width:	$\pm 30 \%$	
Generator impedance:	$\pm 10 \%$	
Surge generator NSG 650	Test level voltage	$\pm 10 \%$
	Phase angle	$V \leq 4 \text{ kV} \pm 15^\circ$ $V > 4 \text{ kV} \pm 25^\circ$
Current Clamp -F61	uA	$\leq \pm 1,8\text{dB}$
Current Clamp F-65A	uA	$\leq \pm 1,8\text{dB}$
Current Clamp F-120-9A	uA	$\leq \pm 1,8\text{dB}$
EM-Clamp	uA	$\leq \pm 1,8\text{dB}$
19" Rack EN61000-4-6	Frequency	$\leq \pm 0,1\text{Hz}$
	Output Level	$\leq \pm 2\text{dB}$