

FCC CLASS A COMPLIANCE REPORT

for

Electromagnetic Emissions

of

IPC

Trade Name : ISPro
Model Number : RPD-1151, RPD-1151T, RPD-1158
Serial Number : N/A
Report Number : 010682-F
Date : Sep. 12, 2001

Prepared for :

ISPro, Inc.

**6F, No. 9, Lane 235, Pao-Chiao Rd., Hsin-Tien,
Taipei Hsien, Taiwan, R.O.C.**

Prepared by :

C&C LABORATORY, CO., LTD.

#B1, 1st Fl., Universal Center,

No. 183, Sec. 1, Tatung Rd., Hsi Chih,

Taipei Hsien, Taiwan, R.O.C.

TEL: (02)8642-2071~3

FAX: (02)8642-2256



**This report shall not be reproduced, except in full, without the written approval of
C&C Laboratory, Co., Ltd.**



TABLE OF CONTENTS

DESCRIPTION	PAGE
VERIFICATION OF COMPLIANCE	3
SYSTEM DESCRIPTION	4
PRODUCT INFORMATION	5
SUPPORT EQUIPMENT	6
MEASUREMENT PROCEDURE & LIMIT (LINE CONDUCTED EMISSION TEST)	7
MEASUREMENT PROCEDURE & LIMIT (RADIATED EMISSION TEST)	9
SUMMARY DATA	12
TEST FACILITY	15
TEST EQUIPMENT	16
BLOCK DIAGRAM OF TEST SETUP	17
APPENDIX 1 PHOTOGRAPHS OF SETUP	18
APPENDIX 2 PHOTOGRAPHS OF EUT	21



VERIFICATION OF COMPLIANCE

Equipment Under Test: IPC

Trade Name: ISPro

Model Number: RPD-1151, RPD-1151T, RPD-1158

Serial Number: N/A

Applicant: **ISPro, Inc.**
6F, No. 9, Lane 235, Pao-Chiao Rd.
Hsin-Tien, Taipei Hsien, Taiwan, R.O.C.

Manufacturer: **ISPro, Inc.**
6F, No. 9, Lane 235, Pao-Chiao Rd.
Hsin-Tien, Taipei Hsien, Taiwan, R.O.C.

Type of Test: FCC Class A

Measurement Procedure: ANSI C63.4: 1992

File Number: 010682-F

Date of test: Aug. 22 ~ Sep. 10, 2001

Deviation: According to applicant's declaration this EUT is a class A product, and to be market in industrial environment only.

Condition of Test Sample: Normal

The above equipment was tested by C&C Laboratory, Co., Ltd. for compliance with the requirements set forth in the FCC Rules and Regulations Part 15, Subpart B and the measurement procedure according to ANSI C63.4. This said equipment in the configuration described in this report shows the maximum emission levels emanating from equipment are within the compliance requirements.

The test results of this report relate only to the tested sample identified in this report.

Kuo Chen

Authorized Signatory

Responsible Party

Officer of the Responsible Party



SYSTEM DESCRIPTION

EUT Test Program:

1. An EMI test software was loaded and executed under Windows environment.
2. A communicated software was loaded and executed to communicate between EUT and PC.
3. EUT (IPC) sends and receives data from PC via Line Cable.
4. Data was sent to monitor filling the screen with upper case of “H” patterns.
5. Test program sequentially exercised all related I/O’s of EUT and sent “H” patterns to all applicable output ports of EUT.
6. Repeat step 3 to 5 Test program is self-repeating throughout the test.



PRODUCT INFORMATION

Housing Type: Metal case

EUT Power Rating: 88-264VAC, 50-60Hz

AC Power during Test 120VAC/60Hz

Power Supply Manufacturer: 1.) HITRON 2.) Sunpower

Power Supply Model Number: 1. HES24-12020 (For RPD-1151& RPD-1151T)
 2. SPP-AS21Z1 (For RPD-1158)

AC Power Cord Type: Shielded, 1.8m (Detachable)

15" TFT LCD Panel Manufacturer: SAMSUNG

15" TFT LCD Panel Model: 2TM150

Touch Screen Model: XS-201 (for RPD-1151T)

Chassis Manufacturer: Images & Shatetek **Model:** RPD-1151/1151T/1158

VGA Cable Type: Shielded, 1.6m (Detachable)

PS/2 Keyboard Cable Type: Shielded, 1.0m (Detachable)

PS/2 Mouse Cable Type: Shielded, 1.0m (Detachable)

Model No.	I/O Port	Touch Screen	Power Supply
RPD-1151	VGA x 1 PS/2 Mouse x 1 PS/2 Keyboard x 1	NO	HITRON HES24-12020
RPD-1151T	VGA x 1 PS/2 Mouse x 1 PS/2 Keyboard x 1 Serial port x 1	YES	HITRON HES24-12020
RPD-1158	PC Connector Port x 8	NO	Sunpower SPP-AS21Z1

Note: According to customer declaration three Models are identical (include PCB Layout) except list as above items.



SUPPORT EQUIPMENT

No.	Equipment	Model #	Serial #	FCC ID	Trade Name	Data Cable	Power Cord
1)	PC	D6923A	TW85000058	FCC DoC	HP	N/A	Unshielded, 1.8m
2)	Modem	231AA	A08631083483	BFJ9D93108US	Hayes	Shielded, 1.8m	Unshielded, 1.5m
3)	Printer	2225C	3006S67978	DSI6XU2225	HP	Shielded, 1.8m	Unshielded, 1.8m

Note: All the above equipment/cables were placed in worse case positions to maximize emission signals during emission test.

Grounding: Grounding was in accordance with the manufacturer's requirements and conditions for the intended use.



MEASUREMENT PROCEDURE (PRELIMINARY LINE CONDUCTED EMISSION TEST)

- 1) The equipment was set up as per the test configuration to simulate typical actual usage per the user's manual. When the EUT is a tabletop system, a wooden table with a height of 0.8 meters is used and is placed on the ground plane as per EN 55022 (see Test Facility for the dimensions of the ground plane used). When the EUT is a floor-standing equipment, it is placed on the ground plane which has a 3-12 mm non-conductive covering to insulate the EUT from the ground plane.
- 2) Support equipment, if needed, was placed as per EN 55022.
- 3) All I/O cables were positioned to simulate typical actual usage as per EN 55022.
- 4) The EUT received AC power through a Line Impedance Stabilization Network (LISN) which supplied power source and was grounded to the ground plane.
- 5) All support equipment received power from a second LISN supplying power of 110VAC/60Hz, if any.
- 6) The EUT test program was started. Emissions were measured on each current carrying line of the EUT using a spectrum analyzer / Receiver connected to the LISN powering the EUT. The LISN has two monitoring points: Line 1 (Hot Side) and Line 2 (Neutral Side). Two scans were taken: one with Line 1 connected to Analyzer / Receiver and Line 2 connected to a 50 ohm load; the second scan had Line 1 connected to a 50 ohm load and Line 2 connected to the Analyzer / Receiver.
- 7) Analyzer / Receiver scanned from 150kHz to 30MHz for emissions in each of the test modes.
- 8) During the above scans, the emissions were maximized by cable manipulation.
- 9) The following test mode(s) were scanned during the preliminary test:

Mode(s):

1. **1024 x 768 Resolution 85Hz (RPD-1151)**
2. **1024 x 768 Resolution 85Hz (RPD-1151T)**
3. **1024 x 768 Resolution 85Hz (RPD-1158)**

- 10) After the preliminary scan, we found the following test mode(s) producing the highest emission level.

Mode(s): 1.

Then, the EUT configuration and cable configuration of the above highest emission level were recorded for reference of final testing.



MEASUREMENT PROCEDURE (FINAL LINE CONDUCTED EMISSION TEST)

- 1) EUT and support equipment was set up on the test bench as per step 10 of the preliminary test.
- 2) A scan was taken on both power lines, Line 1 and Line 2, recording at least the six highest emissions. Emission frequency and amplitude were recorded into a computer in which correction factors were used to calculate the emission level and compare reading to the applicable limit.
- 3) The test data of the worst case condition(s) was reported on the Summary Data page.

Data Sample:

Freq. MHz	Q.P. Raw dBuV	Average Raw dBuV	Q.P. Limit dBuV	Average Limit dBuV	Q.P. Margin dB	Average Margin dB	Note
x.xx	39.2	---	79	66	-39.8	-26.8	L 1

Freq.	= Emission frequency in MHz
Raw dBuV	= Uncorrected Analyzer / Receiver reading
Limit dBuV	= Limit stated in standard
Margin dB	= Reading in reference to limit
Note	= Current carrying line of reading
“---“	= The emission level complied with the Average limits, with at least 2 dB margin, so no further recheck.

LINE CONDUCTED EMISSION LIMIT

Frequency	Maximum RF Line Voltage	
	Q.P.	AVERAGE
150kHz-500kHz	79dBuV	66dBuV
500kHz-5MHz	73dBuV	60dBuV
5MHz-30MHz	73dBuV	60dBuV

Note: The lower limit shall apply at the transition frequency.



MEASUREMENT PROCEDURE (PRELIMINARY RADIATED EMISSION TEST)

- 1) The equipment was set up as per the test configuration to simulate typical actual usage per the user's manual. When the EUT is a tabletop system, a wooden turntable with a height of 0.8 meters is used which is placed on the ground plane as per EN 55022 (see Test Facility for the dimensions of the ground plane used). When the EUT is a floor-standing equipment, it is placed on the ground plane which has a 3-12 mm non-conductive covering to insulate the EUT from the ground plane.
- 2) Support equipment, if needed, was placed as per EN 55022.
- 3) All I/O cables were positioned to simulate typical actual usage as per EN 55022.
- 4) The EUT received AC power source from the outlet socket under the turntable. All support equipment received 110VAC/60Hz power from another socket under the turntable, if any.
- 5) The antenna was placed at 10 meter away from the EUT as stated in EN 55022. The antenna connected to the Analyzer via a cable and at times a pre-amplifier would be used.
- 6) The Analyzer / Receiver quickly scanned from 30MHz to 1000MHz. The EUT test program was started. Emissions were scanned and measured rotating the EUT to 360 degrees and positioning the antenna 1 to 4 meters above the ground plane, in both the vertical and the horizontal polarization, to maximize the emission reading level.
- 7) The following test mode(s) were scanned during the preliminary test:

Mode(s):

1. **1024 x 768 Resolution 85Hz (RPD-1151)**
2. **1024 x 768 Resolution 85Hz (RPD-1151T)**
3. **1024 x 768 Resolution 85Hz (RPD-1158)**

- 8) After the preliminary scan, we found the following test mode(s) producing the highest emission level.

Mode(s): 1.

Then, the EUT and cable configuration, antenna position, polarization and turntable position of the above highest emission level were recorded for final testing.



MEASUREMENT PROCEDURE (FINAL RAIDATED EMISSION TEST)

- 1) EUT and support equipment were set up on the turntable as per step 8 of the preliminary test.
- 2) The Analyzer / Receiver scanned from 30MHz to 1000MHz. Emissions were scanned and measured rotating the EUT to 360 degrees, varying cable placement and positioning the antenna 1 to 4 meters above the ground plane, in both the vertical and the horizontal polarization, to maximize the emission reading level.
- 3) Recorded at least the six highest emissions. Emission frequency, amplitude, were recorded into a computer (The antenna position, polarization and turntable position were kept in raw data file) in which correction factors were used to calculate the emission level and compare reading to the applicable limit.
- 4) The test data of the worst case condition(s) was reported on the Summary Data page.

Data Sample:

Freq. (MHz)	Raw Data (dBuV/m)	Corr. Factor (dB)	Emiss. Level (dBuV/m)	Limits	Margin (dB)
xx.xx	14.0	11.2	26.2	40	-13.8

Freq.	= Emission frequency in MHz
Raw Data (dBuV/m)	= Uncorrected Analyzer / Receiver reading
Corr. Factor (dB)	= Correction factors of antenna factor and cable loss
Emiss. Level	= Raw reading converted to dBuV/m and CF added
Limit dBuV/m	= Limit stated in standard
Margin dB	= Reading in reference to limit



RADIATED EMISSION LIMIT

Frequency (MHz)	Distance (m)	Maximum Field Strength Limit (dBuV/m)
		Q.P.
30-230	10	40
230-1000	10	47

**Note: “/” means the limit line isn’t applicable.



SUMMARY DATA

(LINE CONDUCTED TEST)

Model Number: RPD-1151

Location: Site # 3

Tested by: Jacky Wang

Test Mode: Mode 1

Test Results: Passed

Temperature: 27°C

Humidity: 64%RH

(The chart below shows the highest readings taken from the final data)

FREQ MHz	Q.P. RAW dBuV	AVG RAW dBuV	Q.P. Limit dBuV	AVG Limit dBuV	Q.P. Margin dB	AVG Margin dB	NOTE
0.160	45.2	---	79.0	66.0	-33.8	---	L1
0.970	31.4	---	73.0	60.0	-41.6	---	L1
3.550	32.7	---	73.0	60.0	-40.3	---	L1
4.140	30.4	---	73.0	60.0	-42.6	---	L1
5.480	21.5	---	73.0	60.0	-51.5	---	L1
8.220	19.7	---	73.0	60.0	-53.3	---	L1
0.160	45.7	---	79.0	66.0	-33.3	---	L2
2.200	31.4	---	73.0	60.0	-41.6	---	L2
3.860	34.5	---	73.0	60.0	-38.5	---	L2
3.970	33.6	---	73.0	60.0	-39.4	---	L2
5.520	29.2	---	73.0	60.0	-43.8	---	L2
7.020	22.8	---	73.0	60.0	-50.2	---	L2

L1 = Line One (Hot side) / L2 = Line Two (Neutral side)

****NOTE: “---” denotes the emission level was or more than 2dB below the Average limit, so no re-check anymore.**



SUMMARY DATA (RADIATED EMISSION TEST)

Model Number: RPD-1151

Location: Site # 4

Tested by: Jacky Wang

Polar: Vertical--10m

Test Mode: Mode 1

Test Results: Passed

Detector Function: Quasi-Peak

Temperature: 26°C

Humidity: 60%RH

(The chart below shows the highest readings taken from the final data)

Freq. (MHz)	Raw Data (dBuV/m)	Corr. Factor (dB)	Emiss. Level (dBuV/m)	Limits	Margin (dB)
52.66	16.2	9.5	25.7	40.0	-14.3
135.91	16.6	12.0	28.6	40.0	-11.4
226.30	18.7	11.5	30.2	40.0	-9.8
272.10	20.7	14.8	35.5	47.0	-11.5
360.40	18.7	16.7	35.4	47.0	-11.6
409.00	13.5	18.9	32.4	47.0	-14.6
680.00	8.5	21.8	30.3	47.0	-16.7
748.00	8.5	23.1	31.6	47.0	-15.4



SUMMARY DATA (RADIATED EMISSION TEST)

Model Number: RPD-1151

Location: Site # 4

Tested by: Jacky Wang

Polar: Vertical--10m

Test Mode: Mode 1

Test Results: Passed

Detector Function: Quasi-Peak

Temperature: 26°C

Humidity: 60%RH

(The chart below shows the highest readings taken from the final data)

Freq. (MHz)	Raw Data (dBuV/m)	Corr. Factor (dB)	Emiss. Level (dBuV/m)	Limits	Margin (dB)
135.96	12.5	12.0	24.5	40.0	-15.5
226.70	15.7	11.6	27.3	40.0	-12.7
252.00	13.4	14.2	27.6	47.0	-19.4
259.90	17.0	14.4	31.4	47.0	-15.6
272.00	13.5	14.8	28.3	47.0	-18.7
340.00	13.9	15.9	29.8	47.0	-17.2
360.60	12.7	16.7	29.4	47.0	-17.6
469.40	13.2	20.0	33.2	47.0	-13.8

TEST FACILITY

- Location:** No. 81-1, 210 Lane, Pa-de 2nd Road, Lu-Chu Hsiang, Taoyuan, Taiwan, R. O. C.
- Description:** There are four 3/10m open area test sites and three line conducted labs for final test.
The Open Area Test Sites and the Line Conducted labs are constructed and calibrated to meet the FCC requirements in documents ANSI C63.4: 1992 and CISPR 22/EN 55022 requirements.
- Site Filing:** A site description is on file with the Federal Communications Commission, 7435 Oakland Mills Road, Columbia, MD 21046.

Registration also was made with Voluntary Control Council for Interference (VCCI).
- Site Accreditation:** Accredited by NEMKO (Authorization #: ELA 124) for EMC & A2LA (Certificate #: 824.01) for Emission

Also accredited by BSMI for the product category of Information Technology Equipment.
- Instrument Tolerance:** All measuring equipment is in accord with ANSI C63.4 and CISPR 22 requirements that meet industry regulatory agency and accreditation agency requirement.
- Ground Plane:** Two conductive reference ground planes were used during the Line Conducted Emission, one in vertical and the other in horizontal. The dimensions of these ground planes are as below. The vertical ground plane was placed distancing 40 cm to the rear of the wooden test table on where the EUT and the support equipment were placed during test. The horizontal ground plane projected 50 cm beyond the footprint of the EUT system and distanced 80 cm to the wooden test table. For Radiated Emission Test, one horizontal conductive ground plane extended at least 1m beyond the periphery of the EUT and the largest measuring antenna, and covered the entire area between the EUT and the antenna. It has no holes or gaps having longitudinal dimensions larger than one-tenth of a wavelength at the highest frequency of measurement up to 1GHz.

Site # 3 & # 4 Line Conducted Test Site: At Shielding Room



TEST EQUIPMENT LIST

Instrumentation: The following list contains equipment used at C & C Laboratory, Co., Ltd. for testing. The equipment conforms to the CISPR 16-1 / ANSI C63.2-1988 Specifications for Electromagnetic Interference and Field Strength Instrumentation from 10kHz to 1.0GHz or above .

Equipment used during the tests:

Open Area Test Site: # 4

Open Area Test Site # 4					
EQUIPMENT TYPE	MFR	MODEL NUMBER	SERIAL NUMBER	LAST CAL.	CAL. DUE
Spectrum Analyzer	ADVANTEST	R3132	91700456	02/21/2001	02/20/2002
EMI Test Receiver	R&S	ESVS10	846285/016	04/16/2001	04/15/2002
Precision Dipole	SCHWAZBECK	VHAP	998/999	05/17/2001	05/16/2002
Precision Dipole	SCHWAZBECK	UHAP	981/982	05/17/2001	05/16/2002
Bilog Antenna	CHASE	CBL 6112B	2462	01/16/2001	01/15/2002
Turn Table	Chance most	N/A	N/A	N.C.R	N.C.R
Antenna Tower	Chance most	N/A	N/A	N.C.R	N.C.R
Controller	Chance most	N/A	N/A	N.C.R	N.C.R
RF Switch	ANRITSU	MP59B	M51067	N.C.R	N.C.R
Site NSA	C&C Lab.	N/A	N/A	11/24/2000	11/23/2001

Conducted Emission Test Site: # 3

Conducted Emission Test Site # 3					
EQUIPMENT TYPE	MFR	MODEL NUMBER	SERIAL NUMBER	LAST CAL.	CAL. DUE
EMI Test Receiver	R&S	ESCS30	845552/030	12/07/2000	12/06/2001
LISN	EMCO	3825/2	9003-1628	07/16/2001	07/15/2002
LISN	R&S	ESH2-Z5	843285/010	12/12/2000	12/11/2001

The calibrations of the measuring instruments, including any accessories that may effect such calibration, are checked frequently to assure their accuracy. Adjustments are made and correction factors applied in accordance with instructions contained in the manual for the measuring instrument.

BLOCK DIAGRAM OF TEST SETUP

System Diagram of Connections between EUT and Simulators

EUT: IPC

Trade Name: ISPro

Model Number: RPD-1151

Power Cord: Unshielded, 1.8m

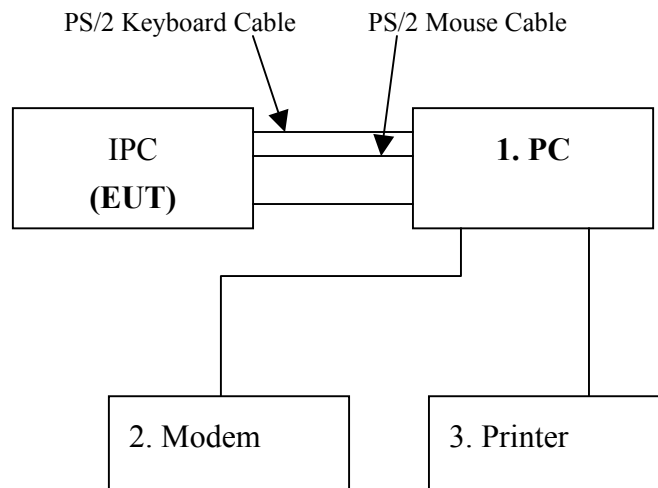



APPENDIX 1

PHOTOGRAPHS OF TEST SETUP

TEST SETUP OF LINE CONDUCTED EMISSION TEST

Front View



Back View



TEST SETUP OF RADIATED EMISSION TEST

Front View



Back View





APPENDIX 2

PHOTOGRAPHS OF EUT

Front view of EUT (RPD-1151)



Back view of EUT (RPD-1151)



Port of EUT (RPD-1151)



Bottom View of EUT (RPD-1151)



Cable of EUT (RPD-1151)



Port of EUT (RPD-1151T)



Cable of EUT (RPD-1151T)



Port of EUT (RPD-1158)



Cable of EUT (RPD-1158)



FCC CLASS A COMPLIANCE REPORT

for

Electromagnetic Emissions

of

IPC

Trade Name : ISPro
Model Number : RPD-1151, RPD-1151T, RPD-1158
Serial Number : N/A
Report Number : 010682-F
Date : Sep. 12, 2001

Prepared for :

ISPro, Inc.

**6F, No. 9, Lane 235, Pao-Chiao Rd., Hsin-Tien,
Taipei Hsien, Taiwan, R.O.C.**

Prepared by :

C&C LABORATORY, CO., LTD.

#B1, 1st Fl., Universal Center,

No. 183, Sec. 1, Tatung Rd., Hsi Chih,

Taipei Hsien, Taiwan, R.O.C.

TEL: (02)8642-2071~3

FAX: (02)8642-2256



**This report shall not be reproduced, except in full, without the written approval of
C&C Laboratory, Co., Ltd.**



TABLE OF CONTENTS

DESCRIPTION	PAGE
VERIFICATION OF COMPLIANCE	3
SYSTEM DESCRIPTION	4
PRODUCT INFORMATION	5
SUPPORT EQUIPMENT	6
MEASUREMENT PROCEDURE & LIMIT (LINE CONDUCTED EMISSION TEST)	7
MEASUREMENT PROCEDURE & LIMIT (RADIATED EMISSION TEST)	9
SUMMARY DATA	12
TEST FACILITY	15
TEST EQUIPMENT	16
BLOCK DIAGRAM OF TEST SETUP	17
APPENDIX 1 PHOTOGRAPHS OF SETUP	18
APPENDIX 2 PHOTOGRAPHS OF EUT	21



VERIFICATION OF COMPLIANCE

Equipment Under Test: IPC

Trade Name: ISPro

Model Number: RPD-1151, RPD-1151T, RPD-1158

Serial Number: N/A

Applicant: **ISPro, Inc.**
6F, No. 9, Lane 235, Pao-Chiao Rd.
Hsin-Tien, Taipei Hsien, Taiwan, R.O.C.

Manufacturer: **ISPro, Inc.**
6F, No. 9, Lane 235, Pao-Chiao Rd.
Hsin-Tien, Taipei Hsien, Taiwan, R.O.C.

Type of Test: FCC Class A

Measurement Procedure: ANSI C63.4: 1992

File Number: 010682-F

Date of test: Aug. 22 ~ Sep. 10, 2001

Deviation: According to applicant's declaration this EUT is a class A product, and to be market in industrial environment only.

Condition of Test Sample: Normal

The above equipment was tested by C&C Laboratory, Co., Ltd. for compliance with the requirements set forth in the FCC Rules and Regulations Part 15, Subpart B and the measurement procedure according to ANSI C63.4. This said equipment in the configuration described in this report shows the maximum emission levels emanating from equipment are within the compliance requirements.

The test results of this report relate only to the tested sample identified in this report.

Kuo Chen

Authorized Signatory

Responsible Party

Officer of the Responsible Party



SYSTEM DESCRIPTION

EUT Test Program:

1. An EMI test software was loaded and executed under Windows environment.
2. A communicated software was loaded and executed to communicate between EUT and PC.
3. EUT (IPC) sends and receives data from PC via Line Cable.
4. Data was sent to monitor filling the screen with upper case of “H” patterns.
5. Test program sequentially exercised all related I/O’s of EUT and sent “H” patterns to all applicable output ports of EUT.
6. Repeat step 3 to 5 Test program is self-repeating throughout the test.



PRODUCT INFORMATION

Housing Type: Metal case

EUT Power Rating: 88-264VAC, 50-60Hz

AC Power during Test 120VAC/60Hz

Power Supply Manufacturer: 1.) HITRON 2.) Sunpower

Power Supply Model Number: 1. HES24-12020 (For RPD-1151& RPD-1151T)
 2. SPP-AS21Z1 (For RPD-1158)

AC Power Cord Type: Shielded, 1.8m (Detachable)

15" TFT LCD Panel Manufacturer: SAMSUNG

15" TFT LCD Panel Model: 2TM150

Touch Screen Model: XS-201 (for RPD-1151T)

Chassis Manufacturer: Images & Shatetek **Model:** ARC-407

VGA Cable Type: Shielded, 1.6m (Detachable)

PS/2 Keyboard Cable Type: Shielded, 1.0m (Detachable)

PS/2 Mouse Cable Type: Shielded, 1.0m (Detachable)

Model No.	I/O Port	Touch Screen	Power Supply
RPD-1151	VGA x 1 PS/2 Mouse x 1 PS/2 Keyboard x 1	NO	HITRON HES24-12020
RPD-1151T	VGA x 1 PS/2 Mouse x 1 PS/2 Keyboard x 1 Serial port x 1	YES	HITRON HES24-12020
RPD-1158	PC Connector Port x 8	NO	Sunpower SPP-AS21Z1

Note: According to customer declaration three Models are identical (include PCB Layout) except list as above items.



SUPPORT EQUIPMENT

No.	Equipment	Model #	Serial #	FCC ID	Trade Name	Data Cable	Power Cord
1)	PC	D6923A	TW85000058	FCC DoC	HP	N/A	Unshielded, 1.8m
2)	Modem	231AA	A08631083483	BFJ9D93108US	Hayes	Shielded, 1.8m	Unshielded, 1.5m
3)	Printer	2225C	3006S67978	DSI6XU2225	HP	Shielded, 1.8m	Unshielded, 1.8m

Note: All the above equipment/cables were placed in worse case positions to maximize emission signals during emission test.

Grounding: Grounding was in accordance with the manufacturer's requirements and conditions for the intended use.



MEASUREMENT PROCEDURE (PRELIMINARY LINE CONDUCTED EMISSION TEST)

- 1) The equipment was set up as per the test configuration to simulate typical actual usage per the user's manual. When the EUT is a tabletop system, a wooden table with a height of 0.8 meters is used and is placed on the ground plane as per EN 55022 (see Test Facility for the dimensions of the ground plane used). When the EUT is a floor-standing equipment, it is placed on the ground plane which has a 3-12 mm non-conductive covering to insulate the EUT from the ground plane.
- 2) Support equipment, if needed, was placed as per EN 55022.
- 3) All I/O cables were positioned to simulate typical actual usage as per EN 55022.
- 4) The EUT received AC power through a Line Impedance Stabilization Network (LISN) which supplied power source and was grounded to the ground plane.
- 5) All support equipment received power from a second LISN supplying power of 110VAC/60Hz, if any.
- 6) The EUT test program was started. Emissions were measured on each current carrying line of the EUT using a spectrum analyzer / Receiver connected to the LISN powering the EUT. The LISN has two monitoring points: Line 1 (Hot Side) and Line 2 (Neutral Side). Two scans were taken: one with Line 1 connected to Analyzer / Receiver and Line 2 connected to a 50 ohm load; the second scan had Line 1 connected to a 50 ohm load and Line 2 connected to the Analyzer / Receiver.
- 7) Analyzer / Receiver scanned from 150kHz to 30MHz for emissions in each of the test modes.
- 8) During the above scans, the emissions were maximized by cable manipulation.
- 9) The following test mode(s) were scanned during the preliminary test:

Mode(s):

- 1. 1024 x 768 Resolution 85Hz (RPD-1151)**
- 2. 1024 x 768 Resolution 85Hz (RPD-1151T)**
- 3. 1024 x 768 Resolution 85Hz (RPD-1158)**

- 10) After the preliminary scan, we found the following test mode(s) producing the highest emission level.

Mode(s): 1.

Then, the EUT configuration and cable configuration of the above highest emission level were recorded for reference of final testing.



MEASUREMENT PROCEDURE (FINAL LINE CONDUCTED EMISSION TEST)

- 1) EUT and support equipment was set up on the test bench as per step 10 of the preliminary test.
- 2) A scan was taken on both power lines, Line 1 and Line 2, recording at least the six highest emissions. Emission frequency and amplitude were recorded into a computer in which correction factors were used to calculate the emission level and compare reading to the applicable limit.
- 3) The test data of the worst case condition(s) was reported on the Summary Data page.

Data Sample:

Freq. MHz	Q.P. Raw dBuV	Average Raw dBuV	Q.P. Limit dBuV	Average Limit dBuV	Q.P. Margin dB	Average Margin dB	Note
x.xx	39.2	---	79	66	-39.8	-26.8	L 1

Freq.	= Emission frequency in MHz
Raw dBuV	= Uncorrected Analyzer / Receiver reading
Limit dBuV	= Limit stated in standard
Margin dB	= Reading in reference to limit
Note	= Current carrying line of reading
“---“	= The emission level complied with the Average limits, with at least 2 dB margin, so no further recheck.

LINE CONDUCTED EMISSION LIMIT

Frequency	Maximum RF Line Voltage	
	Q.P.	AVERAGE
150kHz-500kHz	79dBuV	66dBuV
500kHz-5MHz	73dBuV	60dBuV
5MHz-30MHz	73dBuV	60dBuV

Note: The lower limit shall apply at the transition frequency.



MEASUREMENT PROCEDURE (PRELIMINARY RADIATED EMISSION TEST)

- 1) The equipment was set up as per the test configuration to simulate typical actual usage per the user's manual. When the EUT is a tabletop system, a wooden turntable with a height of 0.8 meters is used which is placed on the ground plane as per EN 55022 (see Test Facility for the dimensions of the ground plane used). When the EUT is a floor-standing equipment, it is placed on the ground plane which has a 3-12 mm non-conductive covering to insulate the EUT from the ground plane.
- 2) Support equipment, if needed, was placed as per EN 55022.
- 3) All I/O cables were positioned to simulate typical actual usage as per EN 55022.
- 4) The EUT received AC power source from the outlet socket under the turntable. All support equipment received 110VAC/60Hz power from another socket under the turntable, if any.
- 5) The antenna was placed at 10 meter away from the EUT as stated in EN 55022. The antenna connected to the Analyzer via a cable and at times a pre-amplifier would be used.
- 6) The Analyzer / Receiver quickly scanned from 30MHz to 1000MHz. The EUT test program was started. Emissions were scanned and measured rotating the EUT to 360 degrees and positioning the antenna 1 to 4 meters above the ground plane, in both the vertical and the horizontal polarization, to maximize the emission reading level.
- 7) The following test mode(s) were scanned during the preliminary test:

Mode(s):

1. 1024 x 768 Resolution 85Hz (RPD-1151)
2. 1024 x 768 Resolution 85Hz (RPD-1151T)
3. 1024 x 768 Resolution 85Hz (RPD-1158)

- 8) After the preliminary scan, we found the following test mode(s) producing the highest emission level.

Mode(s): 1.

Then, the EUT and cable configuration, antenna position, polarization and turntable position of the above highest emission level were recorded for final testing.



MEASUREMENT PROCEDURE (FINAL RAIDATED EMISSION TEST)

- 1) EUT and support equipment were set up on the turntable as per step 8 of the preliminary test.
- 2) The Analyzer / Receiver scanned from 30MHz to 1000MHz. Emissions were scanned and measured rotating the EUT to 360 degrees, varying cable placement and positioning the antenna 1 to 4 meters above the ground plane, in both the vertical and the horizontal polarization, to maximize the emission reading level.
- 3) Recorded at least the six highest emissions. Emission frequency, amplitude, were recorded into a computer (The antenna position, polarization and turntable position were kept in raw data file) in which correction factors were used to calculate the emission level and compare reading to the applicable limit.
- 4) The test data of the worst case condition(s) was reported on the Summary Data page.

Data Sample:

Freq. (MHz)	Raw Data (dBuV/m)	Corr. Factor (dB)	Emiss. Level (dBuV/m)	Limits	Margin (dB)
xx.xx	14.0	11.2	26.2	40	-13.8

Freq.	= Emission frequency in MHz
Raw Data (dBuV/m)	= Uncorrected Analyzer / Receiver reading
Corr. Factor (dB)	= Correction factors of antenna factor and cable loss
Emiss. Level	= Raw reading converted to dBuV/m and CF added
Limit dBuV/m	= Limit stated in standard
Margin dB	= Reading in reference to limit



RADIATED EMISSION LIMIT

Frequency (MHz)	Distance (m)	Maximum Field Strength Limit (dBuV/m)
		Q.P.
30-230	10	40
230-1000	10	47

**Note: “/” means the limit line isn’t applicable.



SUMMARY DATA

(LINE CONDUCTED TEST)

Model Number: RPD-1151

Location: Site # 3

Tested by: Jacky Wang

Test Mode: Mode 1

Test Results: Passed

Temperature: 27°C

Humidity: 64%RH

(The chart below shows the highest readings taken from the final data)

FREQ MHz	Q.P. RAW dBuV	AVG RAW dBuV	Q.P. Limit dBuV	AVG Limit dBuV	Q.P. Margin dB	AVG Margin dB	NOTE
0.160	45.2	---	79.0	66.0	-33.8	---	L1
0.970	31.4	---	73.0	60.0	-41.6	---	L1
3.550	32.7	---	73.0	60.0	-40.3	---	L1
4.140	30.4	---	73.0	60.0	-42.6	---	L1
5.480	21.5	---	73.0	60.0	-51.5	---	L1
8.220	19.7	---	73.0	60.0	-53.3	---	L1
0.160	45.7	---	79.0	66.0	-33.3	---	L2
2.200	31.4	---	73.0	60.0	-41.6	---	L2
3.860	34.5	---	73.0	60.0	-38.5	---	L2
3.970	33.6	---	73.0	60.0	-39.4	---	L2
5.520	29.2	---	73.0	60.0	-43.8	---	L2
7.020	22.8	---	73.0	60.0	-50.2	---	L2

L1 = Line One (Hot side) / L2 = Line Two (Neutral side)

****NOTE: “---” denotes the emission level was or more than 2dB below the Average limit, so no re-check anymore.**



SUMMARY DATA (RADIATED EMISSION TEST)

Model Number: RPD-1151

Location: Site # 4

Tested by: Jacky Wang

Polar: Vertical--10m

Test Mode: Mode 1

Test Results: Passed

Detector Function: Quasi-Peak

Temperature: 26°C

Humidity: 60%RH

(The chart below shows the highest readings taken from the final data)

Freq. (MHz)	Raw Data (dBuV/m)	Corr. Factor (dB)	Emiss. Level (dBuV/m)	Limits	Margin (dB)
52.66	16.2	9.5	25.7	40.0	-14.3
135.91	16.6	12.0	28.6	40.0	-11.4
226.30	18.7	11.5	30.2	40.0	-9.8
272.10	20.7	14.8	35.5	47.0	-11.5
360.40	18.7	16.7	35.4	47.0	-11.6
409.00	13.5	18.9	32.4	47.0	-14.6
680.00	8.5	21.8	30.3	47.0	-16.7
748.00	8.5	23.1	31.6	47.0	-15.4



SUMMARY DATA (RADIATED EMISSION TEST)

Model Number: RPD-1151

Location: Site # 4

Tested by: Jacky Wang

Polar: Vertical--10m

Test Mode: Mode 1

Test Results: Passed

Detector Function: Quasi-Peak

Temperature: 26°C

Humidity: 60%RH

(The chart below shows the highest readings taken from the final data)

Freq. (MHz)	Raw Data (dBuV/m)	Corr. Factor (dB)	Emiss. Level (dBuV/m)	Limits	Margin (dB)
135.96	12.5	12.0	24.5	40.0	-15.5
226.70	15.7	11.6	27.3	40.0	-12.7
252.00	13.4	14.2	27.6	47.0	-19.4
259.90	17.0	14.4	31.4	47.0	-15.6
272.00	13.5	14.8	28.3	47.0	-18.7
340.00	13.9	15.9	29.8	47.0	-17.2
360.60	12.7	16.7	29.4	47.0	-17.6
469.40	13.2	20.0	33.2	47.0	-13.8



TEST FACILITY

- Location:** No. 81-1, 210 Lane, Pa-de 2nd Road, Lu-Chu Hsiang, Taoyuan, Taiwan, R. O. C.
- Description:** There are four 3/10m open area test sites and three line conducted labs for final test.
The Open Area Test Sites and the Line Conducted labs are constructed and calibrated to meet the FCC requirements in documents ANSI C63.4: 1992 and CISPR 22/EN 55022 requirements.
- Site Filing:** A site description is on file with the Federal Communications Commission, 7435 Oakland Mills Road, Columbia, MD 21046.

Registration also was made with Voluntary Control Council for Interference (VCCI).
- Site Accreditation:** Accredited by NEMKO (Authorization #: ELA 124) for EMC & A2LA (Certificate #: 824.01) for Emission

Also accredited by BSMI for the product category of Information Technology Equipment.
- Instrument Tolerance:** All measuring equipment is in accord with ANSI C63.4 and CISPR 22 requirements that meet industry regulatory agency and accreditation agency requirement.
- Ground Plane:** Two conductive reference ground planes were used during the Line Conducted Emission, one in vertical and the other in horizontal. The dimensions of these ground planes are as below. The vertical ground plane was placed distancing 40 cm to the rear of the wooden test table on where the EUT and the support equipment were placed during test. The horizontal ground plane projected 50 cm beyond the footprint of the EUT system and distanced 80 cm to the wooden test table. For Radiated Emission Test, one horizontal conductive ground plane extended at least 1m beyond the periphery of the EUT and the largest measuring antenna, and covered the entire area between the EUT and the antenna. It has no holes or gaps having longitudinal dimensions larger than one-tenth of a wavelength at the highest frequency of measurement up to 1GHz.

Site # 3 & # 4 Line Conducted Test Site: At Shielding Room



TEST EQUIPMENT LIST

Instrumentation: The following list contains equipment used at C & C Laboratory, Co., Ltd. for testing. The equipment conforms to the CISPR 16-1 / ANSI C63.2-1988 Specifications for Electromagnetic Interference and Field Strength Instrumentation from 10kHz to 1.0GHz or above .

Equipment used during the tests:

Open Area Test Site: # 4

Open Area Test Site # 4					
EQUIPMENT TYPE	MFR	MODEL NUMBER	SERIAL NUMBER	LAST CAL.	CAL. DUE
Spectrum Analyzer	ADVANTEST	R3132	91700456	02/21/2001	02/20/2002
EMI Test Receiver	R&S	ESVS10	846285/016	04/16/2001	04/15/2002
Precision Dipole	SCHWAZBECK	VHAP	998/999	05/17/2001	05/16/2002
Precision Dipole	SCHWAZBECK	UHAP	981/982	05/17/2001	05/16/2002
Bilog Antenna	CHASE	CBL 6112B	2462	01/16/2001	01/15/2002
Turn Table	Chance most	N/A	N/A	N.C.R	N.C.R
Antenna Tower	Chance most	N/A	N/A	N.C.R	N.C.R
Controller	Chance most	N/A	N/A	N.C.R	N.C.R
RF Switch	ANRITSU	MP59B	M51067	N.C.R	N.C.R
Site NSA	C&C Lab.	N/A	N/A	11/24/2000	11/23/2001

Conducted Emission Test Site: # 3

Conducted Emission Test Site # 3					
EQUIPMENT TYPE	MFR	MODEL NUMBER	SERIAL NUMBER	LAST CAL.	CAL. DUE
EMI Test Receiver	R&S	ESCS30	845552/030	12/07/2000	12/06/2001
LISN	EMCO	3825/2	9003-1628	07/16/2001	07/15/2002
LISN	R&S	ESH2-Z5	843285/010	12/12/2000	12/11/2001

The calibrations of the measuring instruments, including any accessories that may effect such calibration, are checked frequently to assure their accuracy. Adjustments are made and correction factors applied in accordance with instructions contained in the manual for the measuring instrument.

BLOCK DIAGRAM OF TEST SETUP

System Diagram of Connections between EUT and Simulators

EUT: IPC

Trade Name: ISPro

Model Number: RPD-1151

Power Cord: Unshielded, 1.8m

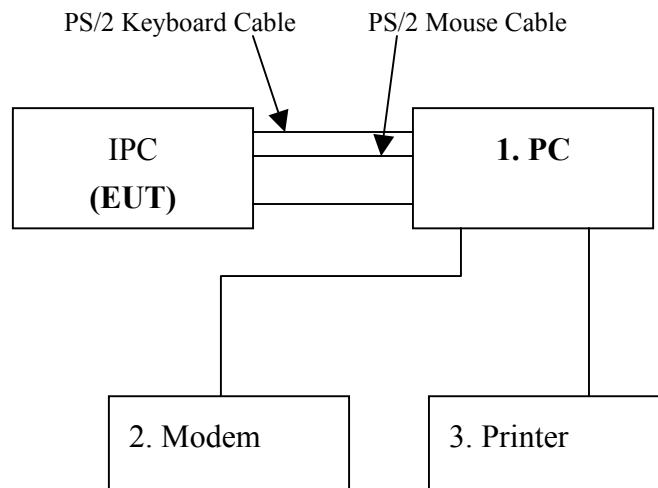



APPENDIX 1

PHOTOGRAPHS OF TEST SETUP

TEST SETUP OF LINE CONDUCTED EMISSION TEST

Front View



Back View



TEST SETUP OF RADIATED EMISSION TEST

Front View



Back View





APPENDIX 2

PHOTOGRAPHS OF EUT

Front view of EUT (RPD-1151)



Back view of EUT (RPD-1151)



Port of EUT (RPD-1151)



Bottom View of EUT (RPD-1151)



Cable of EUT (RPD-1151)

