

AL Pi-Tron CM5 QC

Doc. Rev 1.0

Disclaimer

Kontron Electronics would like to point out that the information contained in this user guide may be subject to alteration, particularly as a result of the constant upgrading of Kontron Electronics products. This document does not entail any guarantee on the part of Kontron Electronics with respect to technical processes described in the user guide or any product characteristics set out in the user guide. Kontron Electronics assumes no responsibility or liability for the use of the described product(s), conveys no license or title under any patent, copyright or mask work rights to these products and makes no representations or warranties that these products are free from patent, copyright or mask work right infringement unless otherwise specified. Applications that are described in this user guide are for illustration purposes only. Kontron Electronics makes no representation or warranty that such application will be suitable for the specified use without further testing or modification. Kontron Electronics expressly informs the user that this user guide only contains a general description of processes and instructions which may not be applicable in every individual case. In cases of doubt, please contact Kontron.

Copyright

This user guide is protected by copyright. All rights are reserved by Kontron. No part of this document may be reproduced, transmitted, transcribed, stored in a retrieval system, or translated into any language or computer language, in any form or by any means (electronic, mechanical, photocopying, recording, or otherwise), without the express written permission of Kontron. Kontron Electronics points out that the information contained in this user guide is constantly being updated in line with the technical alterations and improvements made by Kontron Electronics to the products and thus this user guide only reflects the technical status of the products by Kontron Electronics at the time of publishing.

Brand and product names are trademarks or registered trademarks of their respective owners.

©2025 by Kontron Electronics GmbH

YOUR CONTACT

Kontron Electronics GmbH
Max-Planck-Str. 6
72636 Frickenhausen
Germany

www.kontron-electronics.com

GLOBAL HEADQUARTERS

Kontron-Europe-GmbH
Gutenbergstr. 2
85737 Ismaning
Germany

www.kontron.com

Intended Use

THIS DEVICE AND ASSOCIATED SOFTWARE ARE NOT DESIGNED, MANUFACTURED OR INTENDED FOR USE OR RESALE FOR THE OPERATION OF NUCLEAR FACILITIES, THE NAVIGATION, CONTROL OR SUPPORT OR LIFE SUSTAINING APPLICATIONS, WEAPONS SYSTEMS, OR ANY OTHER APPLICATION IN A HAZARDOUS ENVIRONMENT, OR REQUIRING FAIL-SAFE PERFORMANCE, OR IN WHICH THE FAILURE OF PRODUCTS COULD LEAD DIRECTLY TO DEATH, PERSONAL INJURY, OR SEVERE PHYSICAL OR ENVIRONMENTAL DAMAGE (COLLECTIVELY, "HIGH RISK APPLICATIONS").

You understand and agree that your use of Kontron Electronics devices as a component in High-Risk Applications is entirely at your risk. To minimize the risks associated with your products and applications, you should provide adequate design and operating safeguards. You are solely responsible for compliance with all legal, regulatory, safety, and security related requirements concerning your products. You are responsible to ensure that your systems (and any Kontron Electronics hardware or software components incorporated in your systems) meet all applicable requirements. Unless otherwise stated in the product documentation, the Kontron Electronics device is not provided with error tolerance capabilities and cannot therefore be deemed as being engineered, manufactured or setup to be compliant for implementation or for resale as device in High-Risk Applications. All application and safety related information in this document (including application descriptions, suggested safety measures, suggested Kontron Electronics products, and other materials) is provided for reference only.



Demo software

If the product is delivered with demo software, this software is intended for testing purposes only and is not permitted for real use!

Revision History

Table 1: Revision History

Revision	Brief Description of Changes	Date of Issue	Author/Editor
Rev. 0.1	Draft	2025-07-22	Tur
Rev 1.0	Final Release	2026-05-19	We

Terms and Conditions

Kontron Electronics warrants products in accordance with defined regional warranty periods. For more information about warranty compliance and conformity, and the warranty period in your region, visit www.kontron-electronics.com/downloads

For contact information, refer to the corporate offices contact information on the last page of this user guide or visit our website CONTACT US.

Customer Support

Find Kontron Electronics contacts by visiting: www.kontron-electronics.com

Customer Comments

If you have any difficulties using this user guide, discover an error, or just want to provide some feedback, contact support@kontron-electronics.de. Detail any errors you find. We will correct the errors or problems as soon as possible and provide the revised user guide.

Table of Contents

1	List of Tables	7
2	List of Figures.....	7
3	Symbols.....	8
4	Safety Instructions.....	9
5	Instructions on Handling, Unpacking and Usage	11
5.1	ESD („Electrostatic Discharge“)	11
5.2	Packaging	11
5.3	Scope of Delivery.....	12
5.4	Type Label and Product Identification	12
5.5	General Instructions on Usage	13
6	Introduction	14
7	Starting Up	15
7.1	Connecting to Power Supply	15
7.2	Wiring the DC Mating Power Connector	16
7.3	DIN Rail Mounting	17
7.4	Operating System (OS) and Drivers	17
8	Product Overview	18
8.1	Main Characteristics	19
8.2	Product Variants.....	20
8.3	Related Products and Accessories	20
9	System Specification	21
9.1	Technical Specification	21
9.2	Environmental Specification	22
9.3	Mechanical Specification	23
9.4	Power Specification and Consumption.....	25
9.5	Earthing System	28
9.6	Functional Block Diagram.....	28
9.7	Thermal Considerations.....	29
9.8	Standards, Certifications and Directives.....	30
10	Interface Description	31
10.1	Interface Details	32
10.1.1	Power Connector.....	32
10.1.2	HDMI Interface	32
10.1.3	Ethernet (LAN2, LAN1) Interface.....	32
10.1.4	USB 2.0 Interface.....	32
10.1.5	RS232 Interface.....	32
10.1.6	RS485 Interface	32
10.1.7	CAN Interface	33
10.1.8	DIO Interface	33
10.1.9	Debug Interface	33
10.1.10	USB OTG Interface.....	34
10.1.11	MicroSD Card Slot	34
10.1.12	Switch CAN Address.....	34
10.1.13	Functional Earth Connection.....	35
10.1.14	WLAN Antenna	35
10.2	Connector Pin Assignments.....	36

10.2.1	Input Power Connector (X1)	36
10.2.2	HDMI Connector (X80)	36
10.2.3	Ethernet RJ45 Connector (X20)	37
10.2.4	Ethernet RJ45 Connector (X21)	37
10.2.5	USB Connector (X10)	37
10.2.6	RS232 Connector (X30)	38
10.2.7	RS485/CAN Connector (X40)	38
10.2.8	CAN Address and Termination Switch (S1)	38
10.2.9	DIO Connector (X50)	39
10.2.10	USB Debug Connector (X70)	39
10.2.11	USB OTG Connector (X60)	39
10.2.12	MicroSD Card Slot (microSD)	40
11	Accessing Components	41
11.1	MicroSD Card Slot	41
12	Storage, Transportation and Maintenance	42
12.1	Storage	42
12.2	Transportation	42
12.3	Maintenance	42
12.4	Replacing the Coin Battery	43
13	Technical Support	44
13.1	First Steps – Startup Information Baseboard	44
13.2	License Information	44
14	Product Usage Life Cycle	45
14.1	Warranty	45
14.2	Quality and Environmental Management	46
14.3	Disposal and Recycling	46
14.4	WEEE Compliance	46
15	Appendix	47

1 List of Tables

Table 1: Revision History.....	4
Table 2: Type Label Symbols.....	12
Table 3: Product Identification.....	13
Table 4: Wiring the Power Mating Connector.....	16
Table 5: Product Variants of AL Pi-Tron CM5 QC.....	20
Table 6: Accessories of AL Pi-Tron CM5 QC.....	20
Table 7: Technical Specification.....	21
Table 8: Environmental Conditions.....	22
Table 9: Mechanical Specification.....	23
Table 10: Power Specification.....	25
Table 11: Power Consumption.....	27
Table 12: Digital Output Current.....	27
Table 13: Standards, Certifications and Directives Compliance.....	30
Table 14: Overview of all Interfaces.....	31
Table 15: List of Acronyms.....	47

2 List of Figures

Figure 1: AL Pi-Tron CM5 QC Type Label.....	12
Figure 2: AL Pi-Tron CM5 QC.....	18
Figure 3: Bottom view.....	24
Figure 4: Front View.....	24
Figure 5: Rear View.....	24
Figure 6: Power Tree.....	26
Figure 7: Block Diagram.....	28
Figure 8: Top Side View.....	31
Figure 9: USB-UART Debug-Adapter.....	33
Figure 10: Boot Options.....	34

3 Symbols

The following Symbols may be used in this user guide:



DANGER

Indicates an imminently hazardous situation, which, if not avoided, will result in death or serious injury.



WARNING

Indicates a potentially hazardous situation which, if not avoided, could result in death or serious injury.



CAUTION

Indicates a potentially hazardous situation which, if not avoided, may result in minor or moderate injury. It may also be used to alert against unsafe practices.



NOTICE

Indicates a property damage message.



ESD Sensitive Device

This symbol and title inform that the electronic boards and their components are sensitive to static electricity. Care must always therefore be taken during all handling operations and inspections of this product in order to ensure product integrity at all times.



HOT Surface

Do NOT touch! Allow to cool before servicing.



Information

This symbol indicates general information about the product and the user guide.



Hints and Tips

This symbol precedes helpful hints and tips for daily use.

4 Safety Instructions

Before you begin the installation and operation of the product, please carefully read all safety instructions and warnings. Pay attention to any warning notices attached. Kontron Electronics accepts no liability for damage to equipment or persons resulting from failure to follow the basic safety instructions, even during the warranty period, and is therefore exempt from statutory liability for accidents. The product has been designed and tested in accordance with basic safety requirements and legal guidelines. To ensure safe operation, the user must not only observe the intended operating conditions of the product but also follow the basic safety instructions:

- The product must be used in accordance with the user guide or datasheet.
- All instructions for installation, operation, maintenance, transport or storage that are necessary for the safety of the product or the user must be followed.
- The electrical connection on site must comply with the requirements of the local, country-specific regulations.
- Do not place the appliance near heat sources or in damp locations.
- The only way to completely disconnect the product from the mains power is to disconnect the power supply cable from the power adapter or from the product itself.
- Note: The product is not disconnected from the power supply when it is switched off using the power button or the software.
- Only original accessories approved by Kontron Electronics may be used.
- The available interfaces may only be used with devices and components that comply with the specifications listed in the user guide.
- Ensure that the power consumption of the product does not exceed the value specified on the rating plate and in the user-guide.
- If the product stops working properly, switch it off and secure it to prevent it from being turned on again.
- Basic ESD protection measures must be observed (see user guide).
- AL and DL series products should only be opened to replace a depleted battery. Before opening the housing, disconnect the power supply and ensure that the product is completely de-energized. Ensure that all interfaces of the device are also disconnected.



WARNING

Risk of explosion if the battery is not replaced according to the instructions! (short circuit, reverse polarity, incorrect battery type). Dispose of used batteries in accordance with the manufacturer's instructions.



CAUTION: Risk of Overheating

Sufficient air circulation or cooling is essential to protect the product from overheating. When cooling by air circulation, make sure that the ventilation openings and heat sinks of the product are not covered. Overheating can affect the proper functioning of the product and, in the worst case, lead to its destruction. High ambient temperatures can make cooling more difficult. The ambient temperature limits specified in the user guide must be observed.



CAUTION: Hot Surface

There is a risk of injury from contact with heated components or the housing.

Important notes on the power supply

- Please note: Safe use of the product is only possible if the external DC power supply meets the criteria for LPS and PS2 (UL/IEC 62368-1).
- Connect the product only to a power supply (PSU) that provides the input power (max. current) specified on the Kontron nameplate or in the User-Guide and that complies with the Limited Power Source (LPS) and Power Source (PS2) requirements of UL/IEC 62368-1.
- Safe operation is not possible if exposed parts of circuits carrying dangerous voltages or energies can be touched directly or indirectly.
- Safe operation is not possible if there is no disconnecting device that removes the hazardous energy content from the point of disconnection within 2 seconds.
- The cross-section of the supply wires must be selected in accordance with the maximum current specified on the nameplate of the device, in accordance with the provisions of EN62368-1 or VDE0100 or EN60204 or UL61010-1.
- The power supply serves as the primary disconnect device from the mains (AC) and is used to remove all DC power from the board / system.
- The AL or DL housing must be earthed using the screw provided.

5 Instructions on Handling, Unpacking and Usage

5.1 ESD („Electrostatic Discharge“)



ESD Sensitive Device

Electrostatic discharge (ESD) can damage equipment and impair electrical circuitry.

- Wear ESD-protective clothing and shoes.
- Wear an ESD-preventive wrist strap attached to a good earth ground.
- Check the resistance value of the wrist strap periodically (OK: 1 MΩ to 10 MΩ).
- Transport and store the board in its antistatic bag.
- Handle the board at an approved ESD workstation.
- Handle the board only by the edges.

Do not handle this product out of its protective enclosure while it is not used for operational purposes unless it is otherwise protected.

Whenever possible, unpack or pack this product only at EOS/ESD safe workstations. Where a safe workstation is not guaranteed, it is important for the user to be electrically discharged before touching the product with hands or tools.

It is particularly important to observe standard anti-static precautions when changing piggybacks, ROM devices, jumper settings etc. If the product contains batteries for RTC or memory backup, ensure that the product is not placed on conductive surfaces, including anti-static plastics or sponges. They can cause short circuits and damage the batteries or conductive circuits on the product.

5.2 Packaging

All parts are delivered together in a product specific cardboard package designed to provide adequate protection and absorb shock. Kontron Electronics recommends keeping the packaging to store or transport the product. If it is necessary to store or ship the product then repack it in the same manner as it was delivered.

Please inspect the delivery immediately upon receipt for completeness and integrity. Check the product, the packaging, and any seals that may be present for visible damage or signs of tampering.

If you notice any discrepancies, damage, or missing components, please contact our support team without delay.



Unpacking

Proceed as follows to unpack the unit:

- Remove packaging.
- Do not discard the original packaging. Keep packaging for future relocation or storage.
- Check the delivery for completeness by comparing it with the original order.
- Keep the associated paperwork. It contains important information for handling the unit.
- Check the contents for visible shipping damage.

5.3 Scope of Delivery

Included in this delivery:

- AL Pi-Tron CM5 QC
- Safety Instructions
- DC Power Connector (2-pin Phoenix Contact)

5.4 Type Label and Product Identification

Figure 1: AL Pi-Tron CM5 QC Type Label

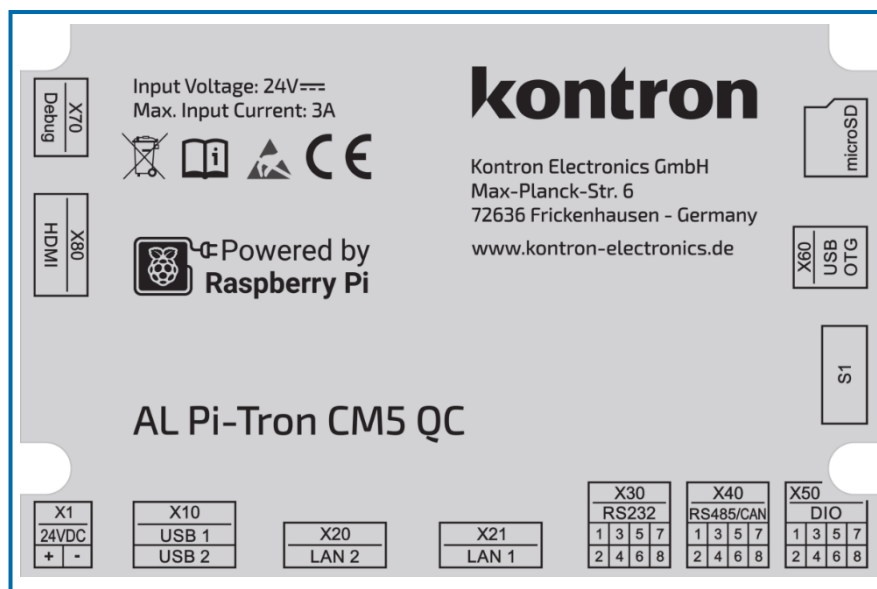
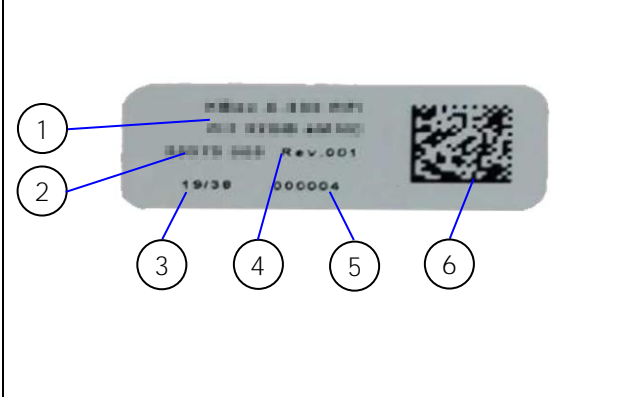

Table 2: Type Label Symbols

Symbol	Description
	The crossed-out wheeled bin symbol (WEEE symbol) indicates that electronic equipment or batteries must not be disposed of with regular household waste. It signifies that the item must be recycled separately to comply with EU WEEE and Battery Directives.
	The open book symbol with an 'i' (information) on the right page is a request to the user of the device to consult the User Guide manual and the online documentation for the product before putting the device into operation.
	The "ESD Susceptibility Symbol" (a hand inside a triangle with a diagonal slash) warns that this device is sensitive to electrostatic discharge and should not be touched without proper grounding.
	The CE mark (Conformité Européenne) is a conformity marking for products sold within the European Economic Area (EEA), it indicates that this product meets health, safety and environmental protection standards.
	The Powered by Raspberry Pi logo shows that the product or device uses Raspberry Pi technology. It indicates to customers that the product is powered by Raspberry Pi computers and/or microcontrollers.

Table 3: Product Identification

	Detail	Description
	1	Product name (AL Pi-Tron CM5 QC)
	2	Article number
	3	Production date
	4	Revision number
	5	Serial number
	6	Data Matrix Code with article-, rev., date and serial number

5.5 General Instructions on Usage

In order to maintain Kontron Electronics' product warranty, this product must not be altered or modified in any way. Changes or modifications to the product, that are not explicitly approved by Kontron Electronics and described in this user guide or received from Kontron Electronics Support as a special handling instruction, will void your warranty.

This product should only be installed in or connected to systems that fulfil all necessary technical and specific environmental requirements. This also applies to the operational temperature range of the specific board version that must not be exceeded. If batteries are present, their temperature restrictions must be considered.

In performing all necessary installation and application operations, only follow the instructions supplied by the present user guide.

6 Introduction

This user guide describes the single board computer AL Pi-Tron CM5 QC. The Advanced RISC Machines (ARM) based module is equipped with Raspberry Pi Compute Module 5. The quad core SoC takes advantage of the optimized power consumption and performance ratio.

The use of this user guide implies a basic knowledge of PC hardware and software. This user guide is focused on describing the special features and is not intended to be a standard PC textbook. New users are recommended to study the short installation procedure, before switching on the power.

All configuration and setup of the module is performed using the Raspberry Pi software. Latest revision of this user guide and datasheet can be downloaded from Kontron Electronics Web Page. The Raspberry Pi software can be downloaded directly from Raspberry Pi.

Kontron Electronics' AL Pi-Tron CM5 QC is developed specifically for easy entry into the world of professional industrial controls, with a wide range of interfaces and for use when space is limited. The fanless design ensures a significantly prolonged lifespan and high system availability.



Exploring the AL Pi-Tron CM5 QC

Before working with the AL Pi-Tron CM5 QC, Kontron Electronics recommends that users take a few minutes to learn about the various parts of the AL Pi-Tron CM5 QC.

7 Starting Up

Before using the system, become familiar with the system components and follow the startup instructions below.

7.1 Connecting to Power Supply

The AL Pi-Tron CM5 QC connects to a DC main power supply using a Phoenix Contact input power connector and the corresponding power cable.



Information

When starting the AL Pi-Tron CM5 QC, the functional earth connection must always be made first and disconnected last. Kontron Electronics recommends that the power cable should be the last connection made to the system. Following the proper cabling sequence helps prevent false power-on conditions, which could otherwise lead to operational failures.



CAUTION

Please make sure to read the safety instructions at the beginning of this user guide before connecting the AL Pi-Tron CM5 QC to a power supply.



WARNING

The current of the power supply should be limited to the maximum value specified on the type label of the AL Pi-Tron CM5 QC.

7.2 Wiring the DC Mating Power Connector

The AL Pi-Tron CM5 QC is connected by the input power connector on the front to a DC power source via a DC power supply wiring consisting of the power mating connector and the assembled wires.

Table 4: Wiring the Power Mating Connector

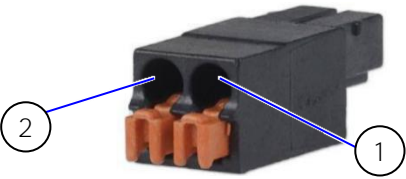
2-Pin Power Mating Connector	Pin	Signal Name
	1	Location for inserting the 24 V wire
	2	Location for inserting the 0 V wire

To wire the power mating connector, follow the steps below:

- Cut two (0.5...1.5 mm²) AWG 20...16 isolated wires to the required length and strip each end 5...7 mm.
- Twist the striped wire-ends and provide them with ferrules.
- Press the contact levers of the power mating connector down - far enough so that you can insert the end of the prepared wires.
- Insert the wires into the corresponding clamp of the Phoenix power mating connector. Make sure that you have the right polarity of the connection. For the pin assignment of the input power connector, refer to Chapter 10.2:
- Input Power Connector.

Information



The wires used for power connections must be clearly marked (+/-) to ensure proper connection to the front panel input power connector and to the main power source. In addition, the cables must have some form of support to minimize the strain on the unit's connectors.

7.3 DIN Rail Mounting

The AL Pi-Tron CM5 QC is a rail mount PC box, designed for use in a DIN rail enclosure or housing by attaching a DIN rail mounting clamp. The DIN rail mounting clamp can be attached on the rear side of the chassis.

To attach the DIN Rail mounting clamp, follow the steps below:

- Make sure that the DIN Rail mounting clamp is in the upright position.
- Clip the top of the DIN rail clamp into the DIN rail and push the bottom of the DIN rail firmly until it clamps on to the bottom of the DIN rail.

7.4 Operating System (OS) and Drivers

The standard AL Pi-Tron CM5 QC is supplied *without* pre-installed OS. Guides to setup an OS and further information about the various interfaces of the AL Pi-Tron CM5 QC are available from Kontron Electronics' online documentation at:

<https://docs.kontron-electronics.de/sw/ked/docs/docs/guides-and-examples/pi-tron-cm5/quickstart/>

8 Product Overview

The AL Pi-Tron CM5 QC is a flexible single board computer fanless device designed for use in demanding applications. Based on the CM5 Broadcom BCM2712 (4x Arm® Cortex®-A76) quad core processor, the AL Pi-Tron CM5 QC features long-term availability and supports a varied number of onboard interfaces to enable connectivity to nearly all applications. A microSD card slot supports memory expansion for flexible data storage.

All variants are also available as a separate product named Board-Line BL Pi-Tron CM5 QC without an aluminium chassis, designed for integration by the customer.

Please contact us for detailed information or visit: <https://www.kontron-electronics.com/>

Figure 2: AL Pi-Tron CM5 QC



Information

The AL Pi-Tron CM5 QC is designed for operation in a DIN rail environment using a vertical orientation.

8.1 Main Characteristics

Main characteristics of the AL Pi-Tron CM5 QC are:

- Broadcom BCM2712 quad-core Cortex-A76, 64-bit SoC @ 2.4GHz
- 2 Gbyte up to 16 GByte LPDDR4 RAM
- 16 GByte up to 64 GByte eMMC
- External microSD card slot
- External Interfaces: 1x HDMI, 1x 10/100 Mbit/s Ethernet, 1x Gbit/s Ethernet, 2x USB 2.0 Host, 1x USB OTG (only for programming eMMC), 1x RS232, 1x RS485, 1x CAN FD, 4x DIO, 1x Debug Interface
- Fanless passive cooling

The AL Pi-Tron CM5 QC is intended for 24/7 continuous operation and longtime industrial applications. All components are selected to ensure a long lifetime.

8.2 Product Variants

Table 5: Product Variants of AL Pi-Tron CM5 QC

Item	Description	Product Number
AL Pi-Tron CM5 QC 4GB/32GB eMMC WLAN	Automation Line with Raspberry Pi Compute Module 5, 4 GB LPDDR4 and 32 GB eMMC and WLAN	50099 098
AL Pi-Tron CM5 QC 2GB/16GB eMMC WLAN	Automation Line with Raspberry Pi Compute Module 5, 2 GB LPDDR4 and 16 GB eMMC and WLAN	50099 104
Other systems on request		

8.3 Related Products and Accessories

The following products are available with the Raspberry Pi Compute Module 5:

- BL Pi-Tron CM5 QC (Board Line, including CM5)
- DK Pi-Tron CM QC (Development Kit, including BL Pi-Tron CM5 QC)
- DK 7" Pi-Tron CM5 QC (Development Kit, including BL Pi-Tron CM5 QC + Touch-Display)
- AL Pi-Tron CM5 QC (Automation Line, including BL Pi-Tron CM5 QC + Aluminium Housing)
- Other systems on request

Table 6: Accessories of AL Pi-Tron CM5 QC

Item	Description	Product Number
SD Card	MicroSD Card 16 GB	1 0600 338
Power Supply	External power supply 230 V AC to 24 V DC / 18 W incl. 2-pin power connector (Phoenix Contact origin no. 1826680)	30099 001
Connector Set mating connector	Connector set contains: <ul style="list-style-type: none"> ➤ 1x RS232: 8-pin; ➤ 1x RS485/CAN: 8-pin; ➤ 1x DIO: 8-pin (Phoenix Contact origin no. 1844594)	30099 006
USB-UART Debug-Adapter	Translates the UART signals provided on the Debug connector to USB for connecting the AL Pi-Tron CM5 QC to a computer	40099 101
USB-Cable	Connects the Mini-B Debug connector of the AL Pi-Tron CM5 QC to the USB-A of the Debug-Adapter	1 860 1154

9 System Specification

9.1 Technical Specification

The AL Pi-Tron CM5 QC implements the following technical specification.

Table 7: Technical Specification

Processor	<ul style="list-style-type: none"> ➤ Broadcom BCM2712 4x Arm® Cortex®-A76, 64-bit SoC @2,4 GHz ➤ 4Kp60 HEVC decoder ➤ OpenGL ES 3.1 graphics, Vulkan 1.3
System Memory	<ul style="list-style-type: none"> ➤ LPDDR4-RAM 2 GB up to 16 GB
Storage	<ul style="list-style-type: none"> ➤ 16 GB eMMC up to 64 GB ➤ FRAM 32 kByte (256 kbit)
Interfaces	<ul style="list-style-type: none"> ➤ 2x USB 2.0 Host, USB A ➤ 1x USB OTG, Micro-USB ➤ 1x Debug, Mini-B USB ➤ 1x HDMI ➤ 1x 1 Gbit/s, 1x 10/100 Mbit/s Ethernet, RJ45 ➤ 1x RS232 ➤ 1x RS485 ➤ 1x CAN FD ➤ 4x DIO ➤ WLAN (2,4 GHz, 5,0 GHz IEEE 802.11 b/g/n/ac) ➤ Bluetooth 5.0 with BLE
Expansion Sockets	<ul style="list-style-type: none"> ➤ 1x MicroSD Card Slot (only for data)
Power	<ul style="list-style-type: none"> ➤ 24 V DC ±20 % Input
Other Features	<ul style="list-style-type: none"> ➤ RTC with battery
Operating System (OS)	<ul style="list-style-type: none"> ➤ Raspberry Pi OS, Yocto, Ubuntu and others ➤ Documentation and support: https://docs.kontron-electronics.de



Demo software

If the product is delivered with demo software, this software is intended for testing purposes only and is not permitted for real use!

9.2 Environmental Specification

Table 8: Environmental Conditions

Temperature (Operating)	0°C...55 °C ambient, non-condensing
Temperature (Storage)	-20...70 °C ambient, non-condensing
IP protection Class	IP20
Pollution	Degree II



Cooling

The AL Pi-Tron CM5 QC is designed for operation in a customer-specific cabinet or device. The maximum temperature range refers only to the limits of the individual components. Do not place heat sources in close proximity to the product. This could otherwise lead to performance losses or an unexpected shutdown of the device.

9.3 Mechanical Specification

Table 9: Mechanical Specification

Dimension	AL Pi-Tron CM5 QC (form factor 4,3")
Width	111 mm (4.37")
Depth	76 mm (3")
Height	25 mm (0,98"), without screw heads
Weight	approx. ~0.25 kg (~0,55 lbs)
Construction	Aluminium housing
Mounting	35 mm DIN Rail

For more detailed mechanical information, refer to the following outline dimensions drawings within this chapter. Each dimension drawing shows the main external mechanical features such as the position and size of mounting holes for the DIN rail mounting clamp (measurements in millimetres).

The DIN rail mounting clamp is 7 mm thick.

Figure 3: Bottom view

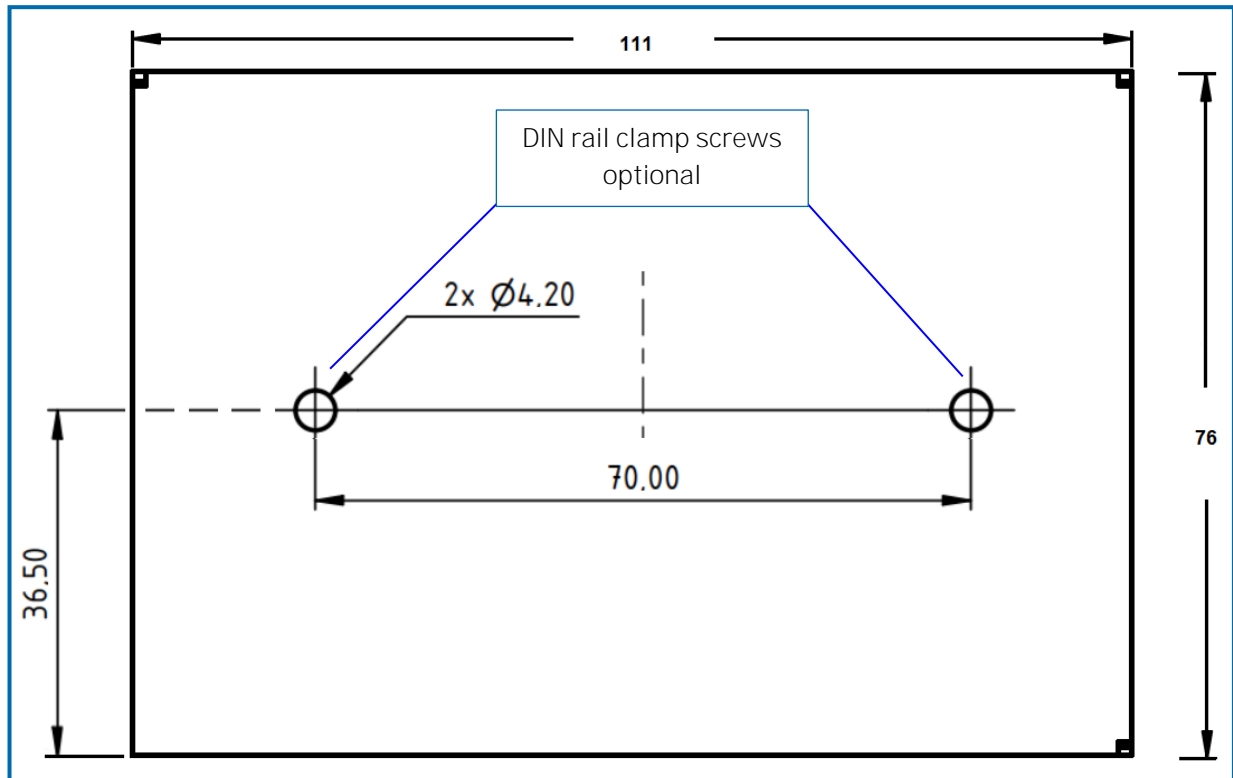

Figure 4: Front View

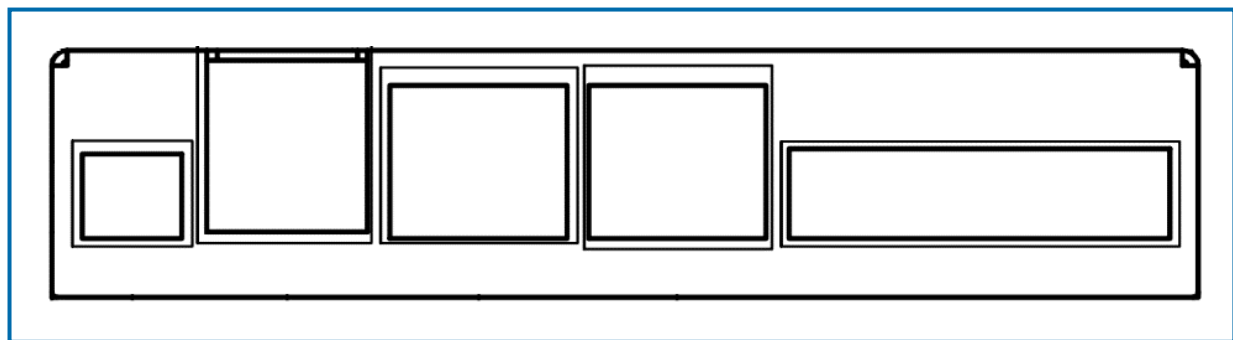
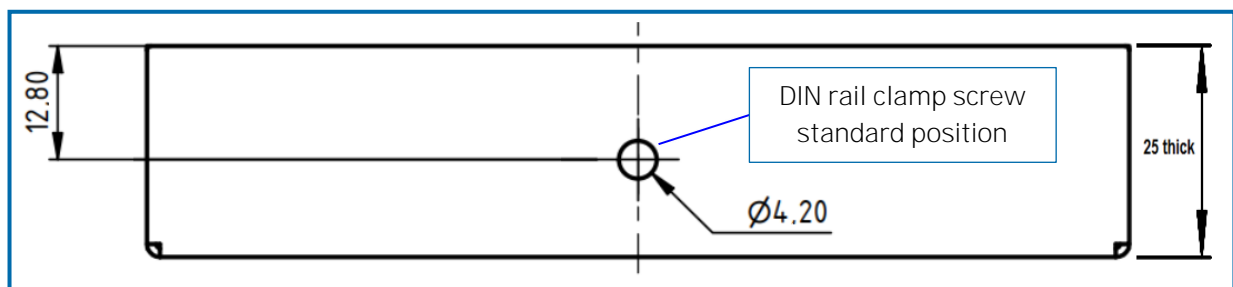

Figure 5: Rear View



9.4 Power Specification and Consumption

The AL Pi-Tron CM5 QC is powered by a 2-pin input power connector on the front and has no internal power supply. The standard input voltage of 24 V DC is converted internally to supply all other required voltages.



WARNING

The current of the power supply should be limited to the maximum value specified on the type label of the AL Pi-Tron CM5 QC.



NOTICE

Performing a forced shutdown can lead to loss of data!

Table 10: Power Specification

Nominal Input Voltage	24 V DC
Input Voltage Range	24 V DC \pm 20 %
Input Power	Max. 72 W (including connected peripherals)
Nominal Power Consumption	4.3 W (Demo idle)
Output Current 5 V	Max. 2 A
Output Current DOUT (24 V)	Max. 2 A
Input Power Mating Connector	2-pin Phoenix Contact 180° FMC 1,5/2-ST-3,5 (Phoenix 1826680)



Information

The CR2032 coin cell is solely used to power the real time clock (RTC) and has no function in the rest of the system's power supply.



Information

The power consumption of the BL Pi-Tron CM5 QC varies depending on the installed components and external peripherals, for more information see the following figure and table.

Figure 6: Power Tree

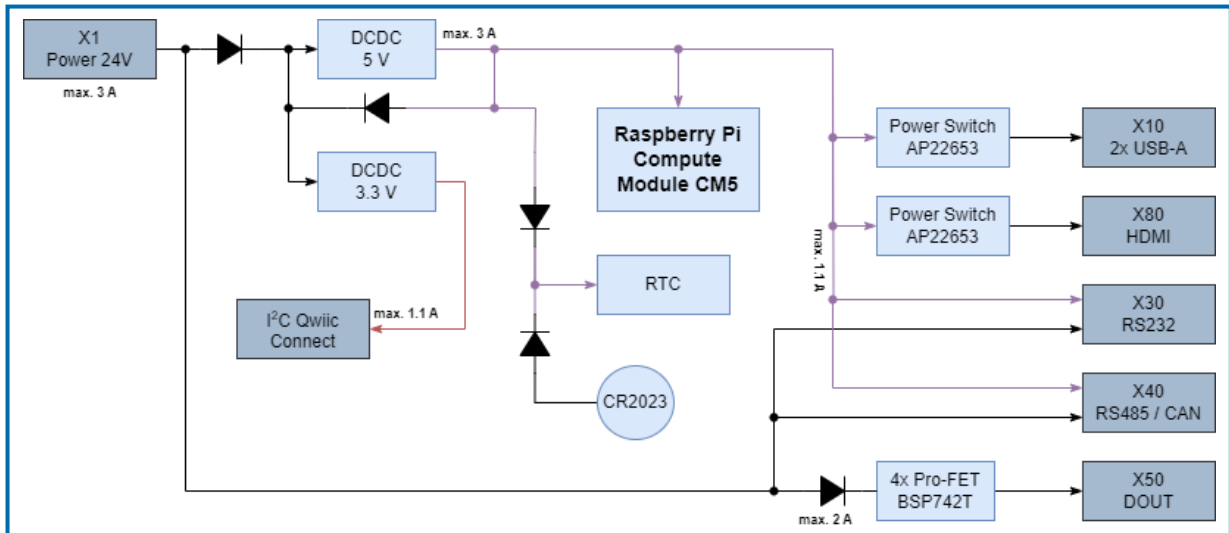

Table 11: Power Consumption

Power Figures SBC	AL Pi-Tron CM5 QC
AL Pi-Tron CM5 QC Deep Sleep Mode	not supported
AL Pi-Tron CM5 QC idle performance	3 W
AL Pi-Tron CM5 QC run	3...11 W
1x HDMI (typ.)	$50 \text{ mA} * 5 \text{ V} = 250 \text{ mW}$
LAN 1	1 W
LAN 2	1 W
2x USB 2.0	$2 * 5 \text{ V} * 500 \text{ mA} = 5,5 \text{ W}$
4x DOUT	$4 * 0.5 \text{ A} * 24 \text{ V} = 48 \text{ W}$

AL Pi-Tron CM5 QC power numbers are typical values based on typical silicon at 25 °C. Power numbers distributed to external devices are max. allowed values, partially overcurrent protected.



NOTICE

Please refer to Compute Module 5 Power Consumption in the datasheet for further information.



NOTICE

Although each DOUT can source up to 800 mA of current, restrictions apply to their combined usage, as seen in the following table.

Table 12: Digital Output Current

Digital Output Combination used	Maximum Current per Channel
Only one DOUT	800 mA
DOUT1 + DOUT2	
DOUT3 + DOUT4	
DOUT1 + DOUT3	500 mA
DOUT2 + DOUT4	
Three or more DOUTs	

9.5 Earthing System

There is a functional earth self-clinching nut on the side of the housing connected to the electronic ground inside the system and to the mounting clamp on the backside.

9.6 Functional Block Diagram

The following diagram highlights the interfaces shown in blue, which are positioned along three edges of the housing.

Figure 7: Block Diagram

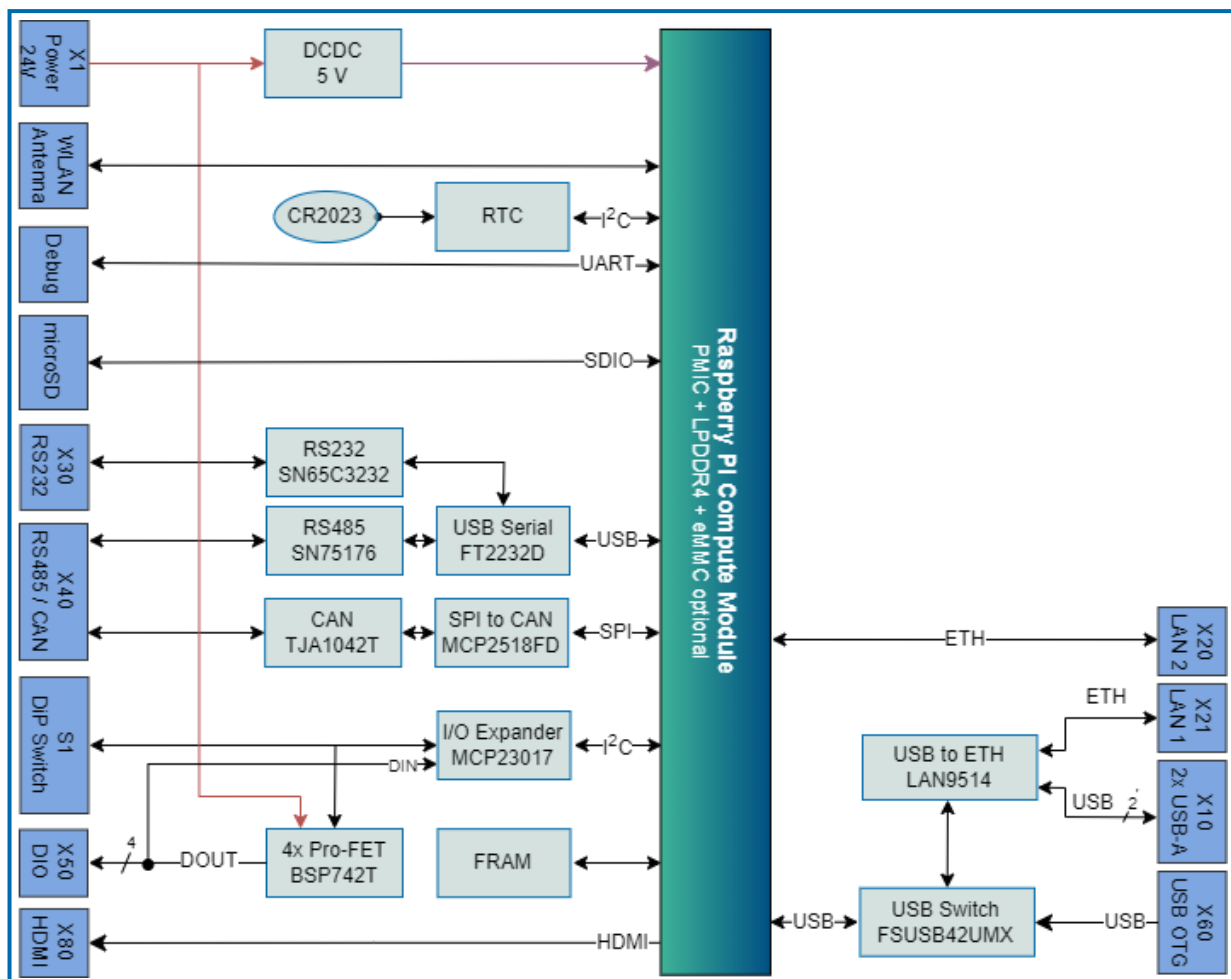

9.7 Thermal Considerations



CAUTION hot Surface

There is a risk of injury from touching the heated housing. Danger of burns!
Housing can get very hot. To avoid burns and personal injury:

- Do not touch the housing when the product is in operation.
- Allow the product to cool before handling.
- Wear protective gloves.
- Always turn the product off when not in use.

The AL Pi-Tron CM5 QC is a fanless and passively cooled system. When mounting the AL Pi-Tron CM5 QC in a DIN rail enclosure or housing take care not to obstruct the airflow over the chassis, as this stops sufficient heat dispersing into the ambient environment and causes a build-up of heat.



Information

The maximum temperature range refers only to the limits of the individual components.

9.8 Standards, Certifications and Directives

The AL Pi-Tron CM5 QC has been designed and tested in accordance with the following standards.



Information

If the user modifies the product, prerequisites for specific approvals such as CE conformity declaration (safety requirements) may no longer apply.

Table 13: Standards, Certifications and Directives Compliance

CE-Mark Compliant with EU Directives	RED Directive
	Product Safety Policy
	RoHS Directive

10 Interface Description

AL Pi-Tron CM5 QC features multiple I/O connectors, LEDs and a push button.

Figure 8: Top Side View

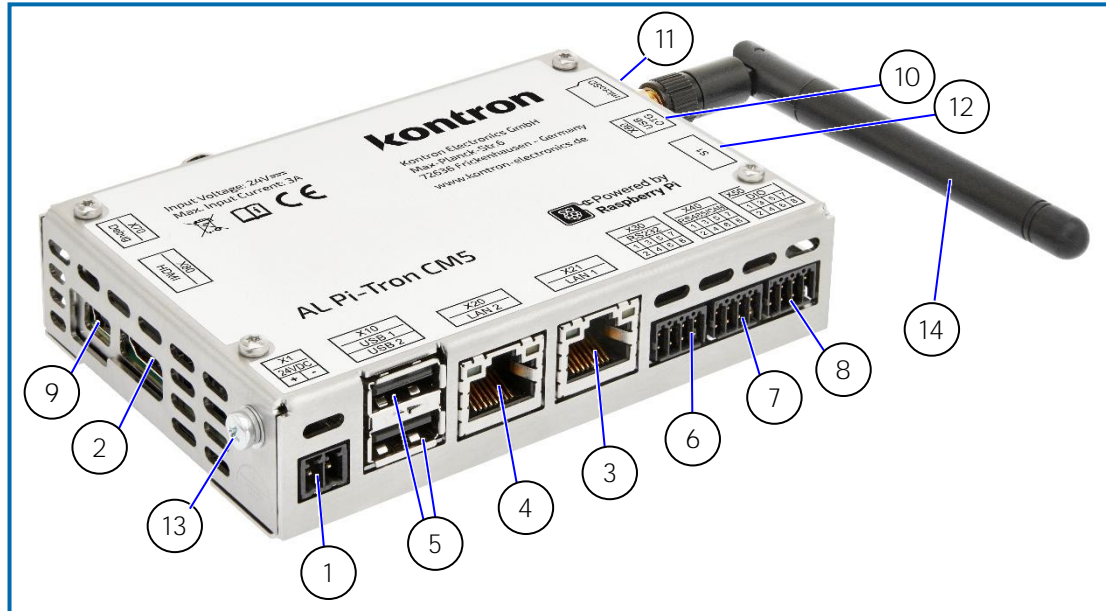

Table 14: Overview of all Interfaces

Item	Label	Function	See Chapter
1	X1	DC Power Connector (2-pin Phoenix Contact)	10.1.1
2	X80	HDMI Connector	10.1.2
3	X20	1 Gbit/s LAN2 RJ-45 Connector	10.1.3
4	X21	10/100 Mbit/s LAN1 RJ-45 Connector	10.1.3
5	X10	USB 2.0 Port 0 / 1 Connector	10.1.4
6	X30	RS232 Connector	10.1.5
7	X40	RS485 / CAN Connector	10.1.6 / 10.1.7
8	X50	DIO Connector	10.1.8
9	X70	Debug UART Connector	10.1.9
10	X60	USB OTG Connector	10.1.10
11	microSD	MicroSD Card Slot	10.1.11
12	S1	Switch CAN Address	10.1.12
13	FE	Functional Earth Connector	10.1.13
14	WLAN	WLAN Antenna	10.1.14

10.1 Interface Details

10.1.1 Power Connector

There is one 2-pin power connector on the top side of the board supporting an input DC voltage range of 24 V DC $\pm 20\%$, see Figure 8 (pos. 1). The mating connector required to connect the power connector to a DC main power source is supplied with the AL Pi-Tron CM5 QC. For information on how to connect the supplied mating connector to the input power source, refer to Chapter 7.2: Wiring the DC Mating Power Connector.

For the pin assignment of the input power connector, refer to Chapter 10.2.1: Input Power Connector (X1)

10.1.2 HDMI Interface

There is one HDMI interface (up to 4k resolution) for video solutions, see Figure 8 (pos. 2). The HDMI interface is not designed for connecting cables longer than 3 m. Depending on the monitor and the installation situation, a suitable HDMI cable with folding ferrite must be selected.

For the pin assignment of the HDMI connector, refer to Chapter 10.2.2: HDMI Connector (X80)

10.1.3 Ethernet (LAN2, LAN1) Interface

There are two LAN ports, see Figure 8 (pos. 3 and 4). In the software these are referred to as ETH0 and ETH1. The assignment between LAN2/LAN1 and ETH0/ETH1 depends on the software. In order to achieve the specified performance of the Ethernet port, shielded category 5 twisted pair cables must be used with 10/100 Mbit/s and Category 5E, 6 or 6E with 1 Gbit/s LAN networks. For the pin assignment of the RJ45 Ethernet connectors, refer to Chapter 10.2.3: Ethernet RJ45 Connector (X20) and 10.2.4: Ethernet RJ45 Connector (X21)

10.1.4 USB 2.0 Interface

There are two USB 2.0 ports allowing for the connection of USB 2.0 compatible devices, see Figure 8 (pos. 5). The USB ports are designed for connecting short cables only.

For the pin assignment of the USB 2.0 connector, refer to Chapter 10.2.5: USB Connector (X10)

10.1.5 RS232 Interface

There is a RS232 interface (RX/TX) supporting RTS/CTS, see Figure 8 (pos. 6). The RS232 interface is not designed for connecting cables longer than 3 m.

For the pin assignment of the RS232 connector, refer to Chapter 10.2.6: RS232 Connector (X30)

10.1.6 RS485 Interface

The RS485 interface in Figure 8 (pos. 7) contains also the wiring for CAN. The RS485 interface is not designed for connecting cables longer than 30 m.

For the pin assignment of the RS485/CAN connector, refer to Chapter 10.2.7: RS485/CAN Connector (X40)

10.1.7 CAN Interface

The CAN interface in Figure 8 (pos. 7) also contains the wiring for RS485. The CAN address switches 1...4 are connected directly to GPIO pins and can therefore also be used for other purposes. The CAN interface is not designed for connecting cables longer than 30 m.

For the pin assignment of the RS485/CAN connector, refer to Chapter 10.2.7: RS485/CAN Connector (X40)

10.1.8 DIO Interface

There is a four port DIO interface available on the front panel of the AL Pi-Tron CM5 QC, see Figure 8 (pos. 8).

Each DIO pin consists of a 24 V high-side switch capable of sourcing up to 800 mA. However, the total current for all DIO pins must not exceed 2,5 A. For more details on the DOUT current capability, refer to Table 12: Digital Output Current. The voltage level is according to the supply voltage. When the output is disabled, the pin can be used as 24 V input.

The DIO interface is not designed for connecting cables longer than 30 m.

For the pin assignment of the DIO connector, refer to Chapter 10.2.9: DIO Connector (X50)

10.1.9 Debug Interface

There is a Debug interface using UART protocol with a Mini-B USB connector, see Figure 8 (pos. 9).

An additional adapter is needed to translate the UART signals provided on the Mini-B USB connector to USB. This adapter must be connected between an USB port on your computer and the debug interface on the AL Pi-Tron CM5 QC board using a standard USB cable.

Figure 9: USB-UART Debug-Adapter

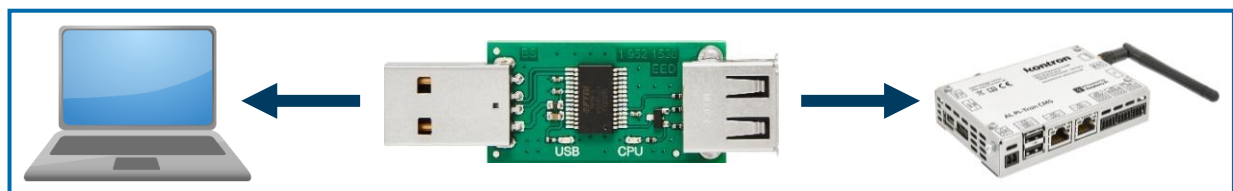

This adapter is only supplied as standard with our development kits but can also be ordered separately.

For more detailed information please have a look at the online documentation <https://docs.kontron-electronics.de>.

This documentation includes all information you need to put your device into operation including a quick start guide as well as further information on how to get access to the Yocto based GitLab software repository and how to make your own software images.

The debug interface is for service purposes and should only be used by qualified personnel.

For the pin assignment of the debug connector, refer to Chapter 10.2.10: USB Debug Connector (X70)

10.1.10 USB OTG Interface

There is a Micro-USB OTG interface for programming eMMC memory, see Figure 8 (pos. 10).

The USB OTG interface is for service and should only be used by qualified personnel.

For the pin assignment of the USB OTG connector, refer to Chapter 10.2.11: USB OTG Connector (X60)

10.1.11 MicroSD Card Slot

There is a card slot to connect a microSD card for extra memory, see Figure 8 (pos. 11).

For the pin assignment of the microSD card slot, refer to Chapter 10.2.12: MicroSD Card Slot (microSD)MicroSD Card Slot

Information
 <p>Pay attention to the manufacturer's lifespan specification. Due to the limited lifespan of SD-Cards/SSD drives Kontron Electronics recommends checking the condition regularly.</p>

Figure 10: Boot Options



10.1.12 Switch CAN Address

There is a dip switch to set the address and to activate the termination, see Figure 8 (pos. 12). The CAN address switches are intended to be used for the CAN Bus and allow for an external user node id selection if the Pi-Tron CM5 QC is used as a CAN slave device. However, the address switches 1..4 are connected directly to common GPIO pins and can therefore also be used for other purposes.

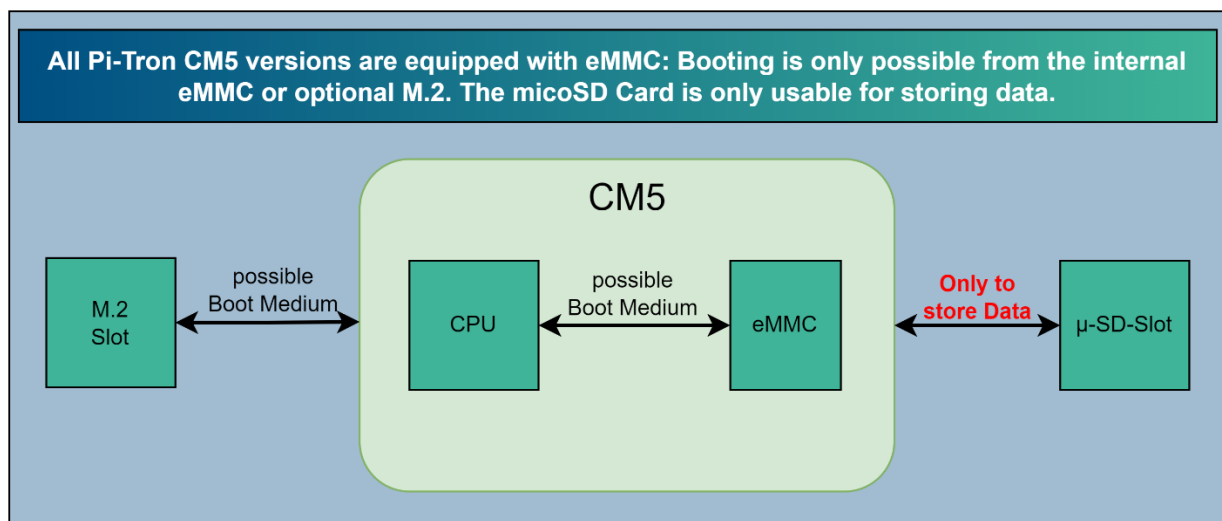
For the dip switch assignment of the CAN address switches, refer to Chapter 10.2.8: CAN Address and Termination Switch (S1)

10.1.13 Functional Earth Connection

There is a functional earth self-clinching nut on the side of the housing connected to the electronic ground inside the system and to the mounting clamp on the backside of the housing, see Figure 8 (pos. 13).

10.1.14 WLAN Antenna

This is a Raspberry Pi pre-certified WLAN antenna, specifically designed for the Compute Module 5 from Raspberry Pi. See Figure 8 (pos. 14).

10.2 Connector Pin Assignments

10.2.1 Input Power Connector (X1)

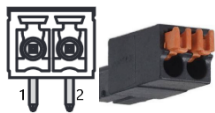
2-Pin Power Mating Connector	Pin	Signal Name
	1	VCC
	2	GND

Phoenix Contact Connector 180° FMC 1,5/2-ST-3,5 (Phoenix 1826680)

10.2.2 HDMI Connector (X80)

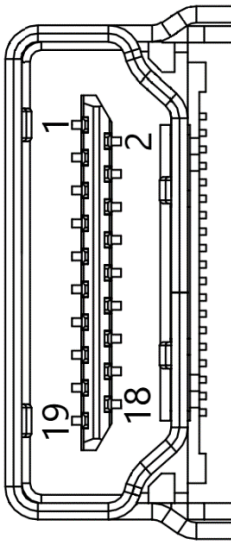
HDMI	Pin	Signal Name
	1	TMDS Data2+
	2	GND
	3	TMDS Data2-
	4	TMDS Data1+
	5	GND
	6	TMDS Data1-
	7	TMDS Data0+
	8	GND
	9	TMDS Data0-
	10	TMDS Clock+
	11	GND
	12	TMDS Clock-
	13	Reserved
	14	Reserved
	15	DDC_CLK
	16	DDC_DATA
	17	GND
	18	+5 V Power
	19	Hot Plug Detect

10.2.3 Ethernet RJ45 Connector (X20)

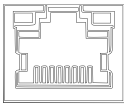
RJ45 (female)	Pin	Signal Name	Pin	Signal Name
	1	TX0+	5	TX2-
	2	TX0-	6	TX1-
	3	TX1+	7	TX3+
	4	TX2+	8	TX3-

Left LED: Activity / Link		Right LED: Activity 10/100/1000	
Off	10 Mbit/s	Off	No LAN connectivity
Green	100 Mbit/s, 1000 Mbit/s	Yellow	Link
		Blinking	Activity

10.2.4 Ethernet RJ45 Connector (X21)

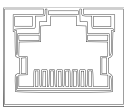
RJ45 (female)	Pin	Signal Name	Pin	Signal Name
	1	TX+	5	n.c.
	2	TX-	6	RX-
	3	RX+	7	n.c.
	4	n.c.	8	n.c.

Left LED: Activity / Link		Right LED: Activity 10/100	
Off	10 Mbit/s	Off	No LAN connectivity
Green	100 Mbit/s	Yellow	Link
		Blinking	Activity

10.2.5 USB Connector (X10)

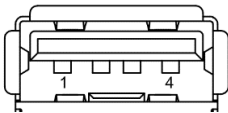
2x USB A 2.0	Pin	Signal Name
	1	+USB_VCC
	2	D-
	3	D+
	4	GND

10.2.6 RS232 Connector (X30)

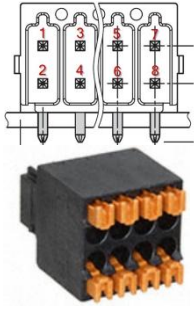
RS232 Interface	Pin	RS232
	1	VIN
	2	GND
	3	TxD
	4	RxD
	5	RTS
	6	CTS
	7	+5 V DC
	8	GND

Phoenix Contact Connector 180° DFMC 0,5/4-ST-2,54 (Phoenix 1844594)

10.2.7 RS485/CAN Connector (X40)

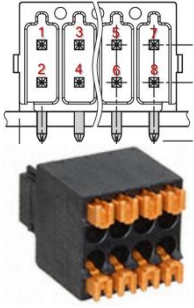
RS485/CAN Interface	Pin	Signal Name
	1	VIN
	2	GND
	3	RS485 A
	4	CAN H
	5	RS485 B
	6	CAN L
	7	+5 V DC
	8	GND

Phoenix Contact Connector 180° DFMC 0,5/4-ST-2,54 (Phoenix 1844594)

10.2.8 CAN Address and Termination Switch (S1)

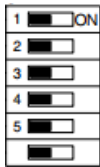
CAN Address	Switch	Signal Name
	1	Address 1
	2	Address 2
	3	Address 3
	4	Address 4
	5	CAN Termination (121 Ω)
	6	RS485 Termination (121 Ω)

10.2.9 DIO Connector (X50)

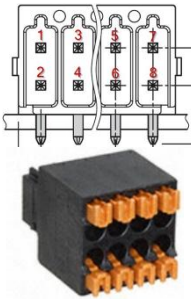
DIO Interface	Pin	Signal Name	Pin	Signal Name
	1	DOUT1 / DIN1 DOUT I _{max} = 800 mA	2	GND
	3	DOUT2 / DIN2 DOUT I _{max} = 800 mA	4	GND
	5	DOUT3 / DIN3 DOUT I _{max} = 800 mA	6	GND
	7	DOUT4 / DIN4 DOUT I _{max} = 800 mA	8	GND

10.2.10 USB Debug Connector (X70)

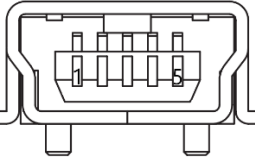
Mini-B USB Connector	Pin	Signal Name
	1	VCC
	2	RXD
	3	TXD
	4	N.C.
	5	GND

10.2.11 USB OTG Connector (X60)

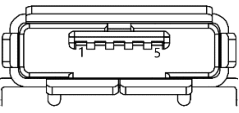
Micro-USB Connector	Pin	Signal Name
	1	+USB_VCC
	2	D-
	3	D+
	4	ID
	5	GND

10.2.12 MicroSD Card Slot (microSD)

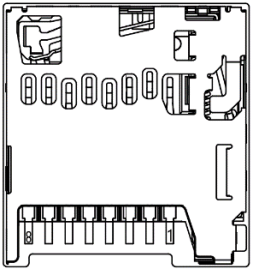
MicroSD Card	Pin	Signal Name
	1	DTA2
	2	CD/DAT3
	3	CMD
	4	VDD
	5	CLK
	6	VSS
	7	DAT0
	8	DAT1



Information

Pay attention to the manufacturer's lifespan specification. Due to the limited lifespan of SD-Cards/SSD drives Kontron Electronics recommends checking the condition regularly.

11 Accessing Components

This chapter contains important information that users must read before accessing components. Follow these procedures properly when accessing or installing component to extend the system.



NOTICE

The AL Pi-Tron CM5 QC is factory configured to meet customer requirements. Kontron Electronics does not recommend opening the system as this may cause damage to internal components. There is a protection label on the AL Pi-Tron CM5 QC.

If the product is opened within the warranty period, the warranty is lost.



ESD Sensitive Device

Follow the safety instructions for components that are sensitive to electrostatic discharge (ESD). Failure to observe this warning notice may result in damage to the product or/and internal components.



Information

Because of the limited predetermined lifespan of expansion devices, Kontron Electronics recommends checking the condition of installed expansion devices regularly and to pay attention to the manufacturer specifications for lifespan.

11.1 MicroSD Card Slot

The AL Pi-Tron CM5 QC supports a removable microSD card. The microSD slot is located on the right-hand side of the AL Pi-Tron CM5 QC.

To remove/install a removable card, perform the following steps:

- Press the card to remove the card out of the slot.
- The card automatically slides out a bit for removal.
- Slide in a card, if needed. Take care of the correct position.

12 Storage, Transportation and Maintenance

12.1 Storage

If the product is not in use for an extended period time, disconnect the power plug from the AC outlet. If it is necessary to store the product then re-pack the product as originally delivered to avoid damage. The storage facility must meet the products environmental requirements as stated within this user guide. Kontron Electronics recommends keeping the original packaging material for future storage or warranty shipments.

12.2 Transportation

To ship the product, use the original packaging, designed to withstand impact and adequately protect the product. When packing or unpacking products always take shock and ESD protection into consideration and use an EOS/ESD safe working area.

12.3 Maintenance

Maintenance or repair on the open product may only be carried out by qualified personnel authorized by Kontron Electronics.

Cleaning:

- For light soiling, clean the product with a dry cloth.
- Carefully remove dust from the surface of the chassis and cooling fins (if present) using a clean, soft brush.
- Stubborn dirt should be removed using a mild detergent and a soft cloth.



NOTICE

Do not use steel wool, metallic threads or solvents like abrasives, alcohol, acetone or benzene for cleaning the AL Pi-Tron CM5 QC.



WARNING

Keep the device dry. Exposure to water may cause damage to the device and pose a risk to the user.

12.4 Replacing the Coin Battery

The coin cell battery (CR2032) with cable must only be replaced with the same type of battery or with a type of battery recommended by Kontron Electronics. If the connected Lithium battery needs to be replaced, follow the steps below:

- Remove the battery by unplugging it from the two-pin connector.
- Connect the new battery to the two-pin connector in the correct orientation. If needed affix the battery itself on a flat surface using double sided tape, a clamp, or a battery holder.
- Pay attention to the polarity of the battery cable.



WARNING

Risk of explosion if the battery is not replaced in accordance with the instructions! (short circuit, reverse polarity, wrong type of battery) Dispose of used batteries in accordance with the manufacturer's instructions.



NOTICE

Do not dispose of coin batteries in general trash collection. Dispose of the battery according to the local regulations dealing with the disposal of these special materials, (e.g. to the collecting points for dispose of batteries).

13 Technical Support

13.1 First Steps – Startup Information Baseboard

For the first startup of the BL Pi-Tron CM5 QC, you will find more information and additional hardware information at the online documentation.

Please follow the link: <https://docs.kontron-electronics.de/>

The online documentation is primarily intended for our Development Kit but will help you also to put your BL Pi-Tron CM5 QC into operation.

Extended Support

For detailed technical support please contact:

E-Mail: support@kontron-electronics.de

Make sure you have the following product identification information in your e-mail:

- Product name
- Product model number
- Serial number (SN) of the unit

Please explain the nature of your problem in your e-mail.



Serial Number

The serial number can be found on the label on the system.

13.2 License Information

Note that the Raspberry Pi OS, obtained from <https://www.raspberrypi.com/software/>, contains licensed as free respectively open-source software under the GNU General Public License, version 2 and/or 3, respectively the GNU Lesser General Public License, versions 2.1 and/or 3.0 and others. Check the respective copyright notices of the package(s) in question.

You can also contact us at:

Kontron Electronics GmbH
Max-Planck-Str. 6
72636 Frickenhausen
Germany

Web: www.kontron-electronics.com

E-Mail: support@kontron-electronics.de

14 Product Usage Life Cycle

14.1 Warranty

Kontron Electronics defines product warranty in accordance with regional warranty definitions. Claims are at Kontron Electronics discretion and limited to the defect being of a material nature. To find out more about the warranty conditions and the defined warranty period for your region, following the steps below:

1. Visit Kontron Electronics Term and Conditions webpage

www.kontron-electronics.com/downloads/

2. Click on the relevant document



NOTICE

The AL Pi-Tron CM5 QC is factory configured to meet customer requirements. Kontron Electronics does not recommend opening the system as this may cause damage to internal components. There is a protection label on the AL Pi-Tron CM5 QC.

If the product is opened within the warranty period, the warranty is lost.

Limitation/Exemption from Warranty Obligation

In general, Kontron Electronics shall not be required to honor the warranty, even during the warranty period, and shall be exempted from the statutory accident liability obligations in the event of damage caused to the product due to failure to observe the following:

- Safety instructions within this user guide
- Warning labels on the product and warning symbols within this user guide
- Information and hints within this user guide

Additionally, alterations or modifications to the product that are not explicitly approved by Kontron Electronics, described in this user guide, or received from Kontron Electronics Support as a special handling instruction will void your warranty.

Within the warranty period, the product should only be opened by Kontron Electronics. Removing the protection label and opening the product within the warranty period exempts the product from the statutory warranty obligation.

Due to their limited service life, parts which by their nature are subject to a particularly high degree of wear (wearing parts) are excluded from the warranty beyond that provided by law.

14.2 Quality and Environmental Management

Kontron Electronics aims to deliver reliable high-end products designed and built for quality, and aims to complying with environmental laws, regulations, and other environmentally oriented requirements. For more information regarding Kontron Electronics' quality and environmental responsibilities, visit www.kontron-electronics.com/company/about-us/germany/

14.3 Disposal and Recycling

Kontron Electronics' products are manufactured to satisfy environmental protection requirements where possible. Many of the components used are capable of being recycled. Final disposal of this product after its service life must be accomplished in accordance with applicable country, state, or local laws or regulations.

14.4 WEEE Compliance

The Waste Electrical and Electronic Equipment (WEEE) Directive aims to:

- Reduce waste arising from electrical and electronic equipment (EEE).
- Make producers of EEE responsible for the environmental impact of their products, especially when the product becomes waste.
- Encourage separate collection and subsequent treatment, reuse, recovery, recycling and sound environmental disposal of EEE.
- Improve the environmental performance of all those involved during the lifecycle of EEE.



Environmental Protection

Environmental protection is a high priority with Kontron Electronics.
Kontron Electronics follows the WEEE directive.
You are encouraged to return our products for proper disposal.

15 Appendix

List of Acronyms

Table 15: List of Acronyms

Acronym	Description	Acronym	Description
AC	Alternating Current	HD/HDD	Hard Disk /Drive
AIN	Analog Input	HDMI	High-Definition Multimedia Interface
AL	Automation Line (Board with housing)	HPM	PICMG Hardware Platform Management specification family
BL	Board Line (Board without housing)	H/W	Hardware
BSP	Board Support Package (Software)	IEC	International Electrotechnical Commission (Standards)
CAN	Controller Area Network (BUS)	IOL	IPMI-Over-LAN
CPI	Advanced Configuration Control Interface	IOT	Internet of Things
CPU	Central Processing Unit	KVM	Keyboard Video Mouse
CSI	Camera Serial Interface	LAN	Local Area Network
DC	Direct Current	LED	Light Emitting Device / Diode
DIN	Deutsches Institut für Normung, German Institute for Standardization (Standards)	LPDDR	Low-Power Double Data Rate (RAM)
DIO	Digital Input/Output	LVD	Low Voltage Device
DK	Development Kit	M.2	Next smaller generation of mSATA
DL	Display Line (Board with Display)	MEI	Management Engine Interface
DOUT	Digital Output	mPCIe	Mini PCI-Express
DP	Display Port	mSATA	Mini SATA
DSI	Display Serial Interface	OS	Operating System
ECC	Error Checking and Correction	PCIe	PCI-Express
EEE	Electrical and Electronic Equipment	RAM	Read Access Memory
EHCI	Enhanced Host Controller Interface	REV	Revision
EMC	Electromagnetic Compatibility	RoHS	Restriction of the use of certain hazardous substances
eMMC	Embedded MultiMediaCard	ROM	Read-only memory
EN	European Norm (Standards)	RTC	Real Time Clock
ESD	Electrostatic Discharge	SATA	Serial-ATA
ETH	Ethernet (LAN)	SEL	System Event Log
GbE	Gigabit Ethernet	SELV	Safety Extra Low Voltage
GPIO	General-Purpose Input/Output	SIO	Super Input/output

Acronym	Description	Acronym	Description
GPU	Graphics Processing Unit	SMBus	System Management Bus
SMWI	System Monitor Web Interface	USB	Universal Serial Bus
SN	Serial Number	USB OTG	USB On-The-Go (Host)
SOL	Serial Over LAN	uSD	microSD (Memory Card)
SSD	Solid State Drive	VGA	Video Graphics Array
TPM	Trusted Platform Module	VLP	Very Low Profile
UEFI	Unified Extensible Firmware Interface	WEEE	Waste Electrical and Electronic Equipment
uHDMI	Micro-HDMI	WLAN	Wireless LAN
UL	Underwriters Laboratories (Standards)	XHCI	eXtensible Host Controller Interface

"List of Acronyms"



About Kontron

Kontron AG is a leading IoT technology company. For more than 20 years, Kontron has been supporting companies from a wide range of industries to achieve their business goals with intelligent solutions. From automated industrial operations, smarter and safer transport to advanced communications, connectivity, medical, and energy solutions, the company delivers technologies that add value for its customers. With the acquisition of Katek SE in early 2024, Kontron significantly strengthens its portfolio with the new GreenTec division, focusing on solar energy and eMobility, and grows to around 8,000 employees in over 20 countries worldwide. Kontron is listed on the SDAX® and TecDAX® of the German Stock Exchange.

For more information, please visit: www.kontron.com

About Kontron Electronics

Kontron Electronics GmbH is a full-service provider in the field of electronics, development and manufacturing services. Our business portfolio includes proprietary and client-specific products, development and design services for complex electronics components, modules and systems, as well as production and assembly services for entire devices. The company is part of the technology corporation Kontron AG.

For more information, please visit: www.kontron-electronics.com

Your contact

Kontron Electronics GmbH

Max-Planck-Straße 6
72636 Frickenhausen, Germany
Tel.: +49 7022 4057-0
info@kontron-electronics.de
www.kontron-electronics.com

Global Headquarters

Kontron Europe GmbH

Gutenbergstraße 2
85737 Ismaning, Germany
Tel.: +49 821 4086-0
info@kontron.com
www.kontron.com