

SL iMX6UL/ULL

Doc. Rev. 0.5

This page has been intentionally left blank

► SL IMX6UL/ULL - USER GUIDE

Disclaimer

Kontron Electronics would like to point out that the information contained in this user guide may be subject to alteration, particularly as a result of the constant upgrading of Kontron Electronics products. This document does not entail any guarantee on the part of Kontron Electronics with respect to technical processes described in the user guide or any product characteristics set out in the user guide. Kontron Electronics assumes no responsibility or liability for the use of the described product(s), conveys no license or title under any patent, copyright or mask work rights to these products and makes no representations or warranties that these products are free from patent, copyright or mask work right infringement unless otherwise specified. Applications that are described in this user guide are for illustration purposes only. Kontron Electronics makes no representation or warranty that such application will be suitable for the specified use without further testing or modification. Kontron Electronics expressly informs the user that this user guide only contains a general description of processes and instructions which may not be applicable in every individual case. In cases of doubt, please contact Kontron.

This user guide is protected by copyright. All rights are reserved by Kontron. No part of this document may be reproduced, transmitted, transcribed, stored in a retrieval system, or translated into any language or computer language, in any form or by any means (electronic, mechanical, photocopying, recording, or otherwise), without the express written permission of Kontron. Kontron Electronics points out that the information contained in this user guide is constantly being updated in line with the technical alterations and improvements made by Kontron Electronics to the products and thus this user guide only reflects the technical status of the products by Kontron Electronics at the time of publishing.

Brand and product names are trademarks or registered trademarks of their respective owners.

©2025 by Kontron Electronics GmbH

Kontron Electronics GmbH

Max-Planck-Str. 6
72636 Frickenhausen
Germany
www.kontron-electronics.de

Kontron Europe GmbH

Gutenbergstr. 2
85737 Ismaning
Germany
www.kontron.com

Intended Use

THIS DEVICE AND ASSOCIATED SOFTWARE ARE NOT DESIGNED, MANUFACTURED OR INTENDED FOR USE OR RESALE FOR THE OPERATION OF NUCLEAR FACILITIES, THE NAVIGATION, CONTROL OR COMMUNICATION SYSTEMS FOR AIRCRAFT OR OTHER TRANSPORTATION, AIR TRAFFIC CONTROL, LIFE SUPPORT OR LIFE SUSTAINING APPLICATIONS, WEAPONS SYSTEMS, OR ANY OTHER APPLICATION IN A HAZARDOUS ENVIRONMENT, OR REQUIRING FAIL-SAFE PERFORMANCE, OR IN WHICH THE FAILURE OF PRODUCTS COULD LEAD DIRECTLY TO DEATH, PERSONAL INJURY, OR SEVERE PHYSICAL OR ENVIRONMENTAL DAMAGE (COLLECTIVELY, "HIGH RISK APPLICATIONS").

You understand and agree that your use of Kontron Electronics devices as a component in High Risk Applications is entirely at your risk. To minimize the risks associated with your products and applications, you should provide adequate design and operating safeguards. You are solely responsible for compliance with all legal, regulatory, safety, and security related requirements concerning your products. You are responsible to ensure that your systems (and any Kontron Electronics hardware or software components incorporated in your systems) meet all applicable requirements. Unless otherwise stated in the product documentation, the Kontron Electronics device is not provided with error-tolerance capabilities and cannot therefore be deemed as being engineered, manufactured or setup to be compliant for implementation or for resale as device in High Risk Applications. All application and safety related information in this document (including application descriptions, suggested safety measures, suggested Kontron Electronics products, and other materials) is provided for reference only.

Revision History

Revision	Brief Description of Changes	Date of Issue	Author /Editor
0.1	Basic draft	2020-February-14	Gb
0.2	Preliminary Version	2020-March-13	Gb/KI
0.3	Additional information in chapters 5.1.3 and 5.3.2	2020-August-05	Gb
0.4	New address Kontron Headquarter	2021-January-27	KI
0.5	Corrected specifications of SoM	2025-November-03	Tur

Customer Support

Find Kontron Electronics contacts by visiting: <http://www.kontron-electronics.de>.

Customer Comments

If you have any difficulties using this user guide, discover an error, or just want to provide some feedback, contact support@kontron-electronics.de. Detail any errors you find. We will correct the errors or problems as soon as possible and provide the revised user guide.

Symbols

The following symbols may be used in this user guide

DANGER

DANGER indicates a hazardous situation which, if not avoided, will result in death or serious injury.

WARNING

WARNING indicates a hazardous situation which, if not avoided, could result in death or serious injury.

NOTICE

NOTICE indicates a property damage message.

CAUTION

CAUTION indicates a hazardous situation which, if not avoided, may result in minor or moderate injury.



Electric Shock!

This symbol and title warn of hazards due to electrical shocks (> 60 V) when touching products or parts of products. Failure to observe the precautions indicated and/or prescribed by the law may endanger your life/health and/or result in damage to your material.



ESD Sensitive Device!

This symbol and title inform that the electronic boards and their components are sensitive to static electricity. Care must therefore be taken during all handling operations and inspections of this product in order to ensure product integrity at all times.



HOT Surface!

Do NOT touch! Allow to cool before servicing.



Laser!

This symbol informs of the risk of exposure to laser beam and light emitting devices (LEDs) from an electrical device. Eye protection per manufacturer notice shall review before servicing.



This symbol indicates general information about the product and the user guide.

This symbol also indicates detail information about the specific product configuration.



This symbol precedes helpful hints and tips for daily use.

Special Handling and Unpacking Instruction

NOTICE**ESD Sensitive Device!**

Electronic boards and their components are sensitive to static electricity. Therefore, care must be taken during all handling operations and inspections of this product, in order to ensure product integrity at all times.

Do not handle this product out of its protective enclosure while it is not used for operational purposes unless it is otherwise protected.

Whenever possible, unpack or pack this product only at EOS/ESD safe work stations. Where a safe work station is not guaranteed, it is important for the user to be electrically discharged before touching the product with his/her hands or tools. This is most easily done by touching a metal part of your system housing.

It is particularly important to observe standard anti-static precautions when changing piggybacks, ROM devices, jumper settings etc. If the product contains batteries for RTC or memory backup, ensure that the product is not placed on conductive surfaces, including anti-static plastics or sponges. They can cause short circuits and damage the batteries or conductive circuits on the product.

Quality and Environmental Management

Kontron aims to deliver reliable high-end products designed and built for quality, and aims to complying with environmental laws, regulations, and other environmentally oriented requirements.

For more information regarding Kontron's quality and environmental responsibilities, visit <https://www.kontron-electronics.de/unternehmen/qualitaet/>.

Table of Contents

Symbols	6
Special Handling and Unpacking Instruction	7
Quality and Environmental Management	7
Table of Contents	8
List of Tables	9
List of Figures	9
1/ Introduction	10
2/ Description	11
2.1. Product Variants and Accessories	12
3/ System Specifications	13
3.1. Component Main Data	13
3.2. Environmental Conditions	14
3.3. Functional Block Diagram	15
4/ Board and Connectors	16
4.1.1. Connectors	16
4.2. Mainboard view and I/O locations	16
4.3. Bottom Side	17
4.4. Mechanical Drawings	18
4.5. Pinout of SL iMX6UL/ULL	20
4.5.1. Pinout of SL iMX6UL/ULL	21
5/ Installation	24
5.1. Power Control	24
5.1.1. Power Supply	24
5.1.2. Supply voltage	24
5.1.3. Supply current	24
5.2. Reset pin	24
5.3. Boot Mode	25
5.3.1. SD/MMC manufacture mode	25
5.3.2. Serial Downloader	25
5.4. SD card	26
5.5. Ethernet	26
6/ Thermal considerations	27
7/ Reflow profile	28
8/ Technical Support	29
8.1. First Steps – Startup-Information Baseboard	29
8.2. Extended Support	29
8.3. Disclaimer & License Information	29
About Kontron Electronics	30

List of Tables

Table 1: Product Variants of SL iMX6UL/ULL.....	12
Table 2: Component Main Data.....	13
Table 3: Environmental Conditions.....	14
Table 4: Connectors of SL iMX6UL/ULL.....	16
Table 5: Pinout of SL iMX6UL/ULL castellated pads.....	21
Table 6: Pinout of SL iMX6UL/ULL LGA pads.....	23
Table 7: Supply voltage.....	24
Table 8: Supply current.....	24
Table 9: Boot mode pin settings.....	25
Table 10: Reflow profile.....	28

List of Figures

Figure 1: 25,5x25,5mm SoM with castellation and LGA Pads.....	11
Figure 2: Block Diagram.....	15
Figure 3: Top View.....	16
Figure 4: Bottom View.....	17
Figure 5: Dimensions of SL iMX6UL/ULL.....	18
Figure 6: Thickness from side view.....	18
Figure 7: PCB land pattern.....	19
Figure 8: pin assignment.....	20
Figure 9: SD-Card connection example.....	26
Figure 10: Ethernet connection example.....	26
Figure 11: Reflow Classification Profile.....	28

1/ Introduction

This user guide describes the 25,5mmx25,5mm SoM form factor module – SL iMX6UL/ULL. The Advanced RISC Machines (ARM) based module is equipped with a NXP i.MX6UL/ULL processor. The single core SoC takes advantage of the optimized power consumption and performance ratio.

The use of this user guide implies a basic knowledge of PC hardware and software. This user guide is focused on describing the special features and is not intended to be a standard PC textbook. New users are recommended to study the short installation procedure, before switching on the power.

Latest revision of this user guide, datasheet, and BSPs (Board Support Packages) can be downloaded from Kontron Electronics Web Page.

2/ Description

The SL iMX6UL/ULL is a very small System-on-Module (SoM) using NXP's i.MX6UL/ULL processor with ARM Cortex A7. The SL iMX6UL/ULL is a highly integrated, small sized module for integration in embedded systems with 25,5mmx25,5mm footprint.

The complexity of the DDR3 memory, power management and processor connection are contained in the 8-layer SOM and simplifies baseboard development.

Figure 1: 25,5x25,5mm SoM with castellation and LGA Pads

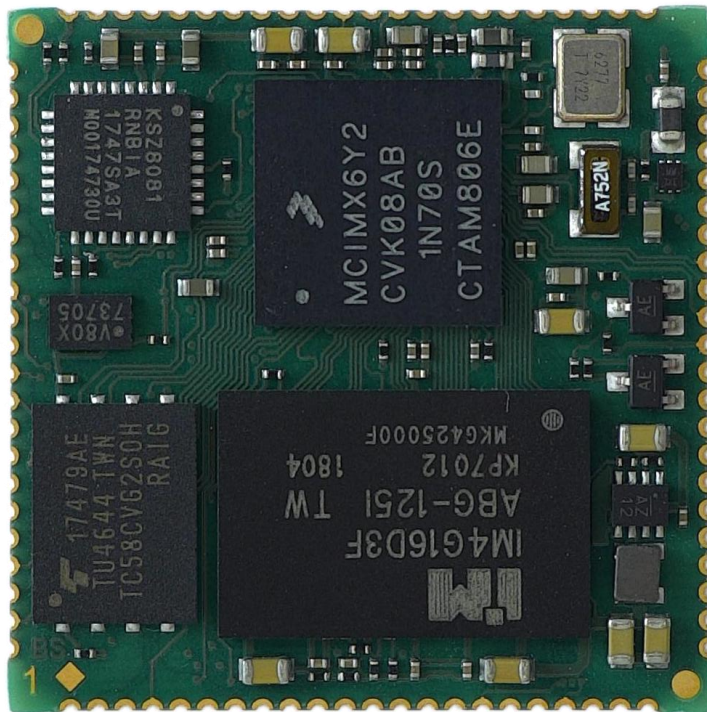

Main characteristics of the SL iMX6UL/ULL are:

- ▶ Single Cortex A7-Core with up to 800 MHz and less than 1 W max power
- ▶ Up to 1 GB DDR3L memory down
- ▶ 256 to 512 MB SLC NAND-Flash
- ▶ 2 MB QSPI boot flash
- ▶ Parallel LCD Display up to WXGA (1366x768)
- ▶ 2x USB 2.0 OTG, HS/FS, Device or Host with PHY
- ▶ 2x 10/100 Ethernet with IEEE 1588, 1x Ethernet 100Mbit with integrated phy
- ▶ 1x SPI, 2x I²C, 2x PWM
- ▶ 3x 12-bit ADC
- ▶ multiple GPIOs
- ▶ 3x UART
- ▶ 1x CAN Bus interface (2.0 B)

Please keep in mind, that not all interfaces are available simultaneously due to the amount of port pins and multiple multiplexing possibilities.

2.1. Product Variants and Accessories

Following variants are planned:

Table 1: Product Variants of SL iMX6UL/ULL

Board	Description	Product Number
SL iMX6 UL 256/256	SoM with NXP single core i.MX6 UL G2 processor, 256 MB DDR3L and 256 MB SLC NAND Flash	40099 123
SL iMX6 UL 512/512	SoM with NXP single core i.MX6 UL G2 processor, 512 MB DDR3L and 512 MB SLC NAND Flash	40099 122
SL iMX6 ULL 256/256	SoM with NXP single core i.MX6 ULL Y2 processor, 256 MB DDR3L and 256 MB SLC NAND Flash	40099 144
SL iMX6 ULL 512/512	SoM with NXP single core i.MX6 UL Y2 processor, 512 MB DDR3L and 512 MB SLC NAND Flash	40099 145

The following accessories are available:

- ▶ i.MX6 UL Evaluation Kit without display (product no. 50099 061)
- ▶ i.MX6 UL Evaluation Kit with display (product no. 50099 058)
- ▶ i.MX6 ULL Evaluation Kit without display (product no. 50099 046)
- ▶ i.MX6 ULL Evaluation Kit with display (product no. 50099 042)

3/ System Specifications

3.1. Component Main Data

The table below summarizes the SoM's features.

Table 2: Component Main Data

SL iMX6UL/ULL	
Form factor	25,5x25,5mm with 88 castellated pads and 38 LGA pads
Weight	2g
Processor	NXP's i.MX6 UL/ULL with 9mm x 9mm BGA package in 0.5mm pitch (industrial version) <ul style="list-style-type: none"> ▶ i.MX6 UL CPU: MCIMX6G2CVK05AB ▶ i.MX6 ULL CPU: MCIMX6Y2CVK08AB
Memory	<p>400 MHz 16-bit DDR3L</p> <ul style="list-style-type: none"> ▶ 256 MByte: 1x 2 Gbit density 128 M x16 DDR3L parts ▶ 512 MByte: 1x 4 Gbit density 256 M x16 DDR3L parts <p>The following memory types are used:</p> <p style="margin-left: 40px;">256MByte: Samsung: K4B2G1646F-BMMA Nanya: NT5CC128M16JR-EKI Winbond: W632GU6NB11I Micron: MT41K128M16JT-125 IT:K</p> <p style="margin-left: 40px;">512MByte: Samsung: K4B4G1646E-BMMA Nanya: NT5CC256M16ER-EKI Intelligent Memory: IM4G16D3FABG-125I Micron: MT41K256M16TW-107 XIT:P</p>
Boot Flash	1 MB SPI NOR flash in USON (2x3mm) package
Bootloader/BIOS	U-Boot Bootloader, Flash for Bootloader connected to ECSPi2
SLC NAND Flash	QSPI NAND Flash in WSON 8x6mm package connected on QSPIA
Display	<ul style="list-style-type: none"> ▶ 24-bit RGB ▶ Resolution: up to WXGA (1366 x 768) @60 fps
Onboard Controllers	
Ethernet Controller	1x 100Mbit PHY KSZ8081RNBIA
Watchdog Timer	3x CPU internal watchdog
System Management Controller	No dedicated System Management Controller on module System settings can be arranged in U-Boot environment variables
H/W Status Monitor	CPU internal temperature monitoring sensor
Security	No security chip on module
Power management	No PMIC on module. Discrete power supply is used

Operating System Support	Linux Yocto
Default Interfaces	
I2C	2x I2C interfaces which are derived from the SoC
LAN, USB	<ul style="list-style-type: none"> ▶ 2x 100Mbit-Ethernet ▶ 2x USB2.0 OTG
Display	24Bit RGB with up to WXGA (1366 × 768) @60 fps
SD-Card	2x SDIO 4Bit
UART	3x UART, one is used for serial console by default
GPIO	16x General Purpose Inputs/Outputs (GPIO)
PWM	2x from SoC <ul style="list-style-type: none"> ▶ PWM8: used for Buzzer on baseboard ▶ PWM7: used for TFT backlight on baseboard
other Connectivity	1x CAN
Power	
Consumption	Maximum Power consumption of the board is < 1 W
Input Voltage	Single supply +3.3V

3.2. Environmental Conditions

Table 3: Environmental Conditions

Operating	<ul style="list-style-type: none"> ▶ industrial: -40°C to 85°C ▶ relative humidity (non-condensing) 10% to 93% at 40°C
Storage	<ul style="list-style-type: none"> ▶ commercial grade: -40°C to +85°C ▶ relative humidity (non-condensing) 10% to 93% at 40°C

3.3. Functional Block Diagram

The block diagram shows a detailed structure of the SL iMX6UL/ULL module.

Figure 2: Block Diagram

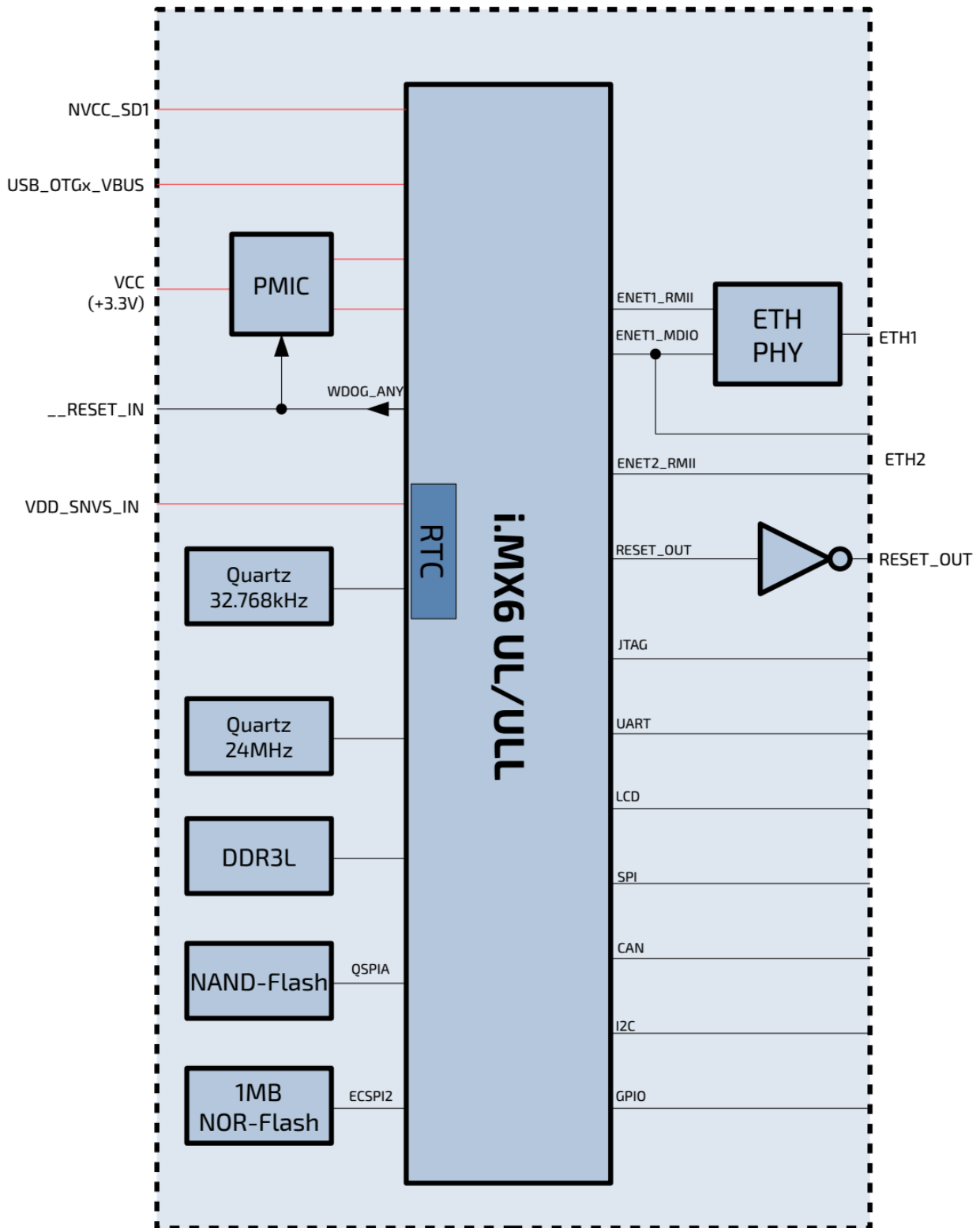

4/ Board and Connectors

4.1.1. Connectors

Table 4: Connectors of SL iMX6UL/ULL

Connector	Function	Remark
Castellated pads and LGA pads	Central Interface	solderable

4.2. Mainboard view and I/O locations

Figure 3: Top View

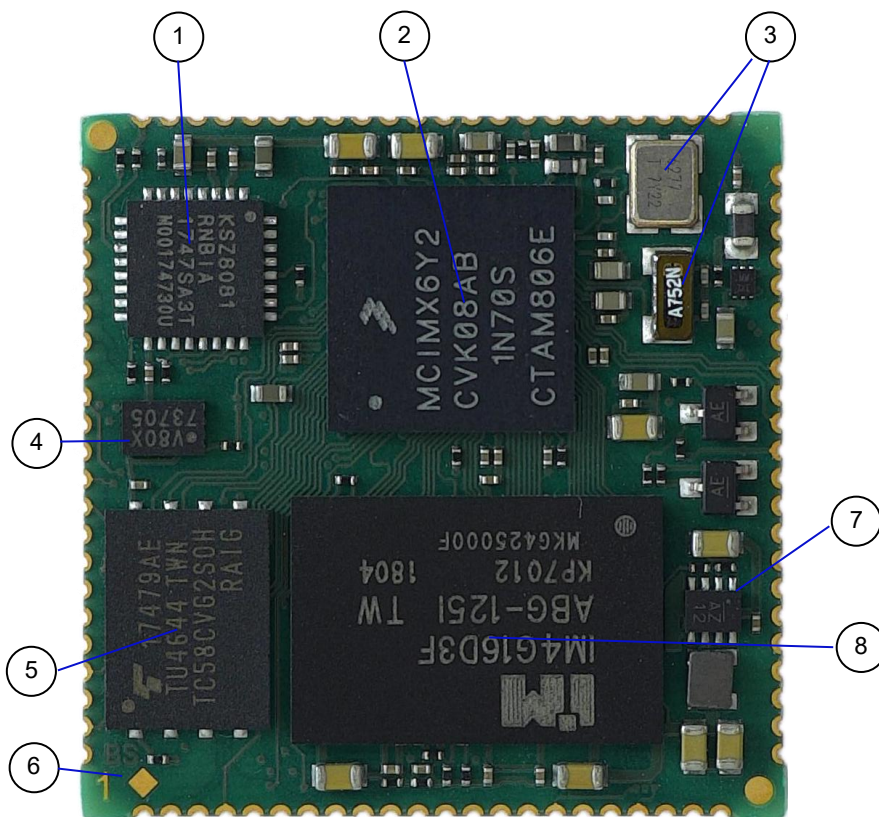

1. Ethernet Phy
2. i.MX6 UL/ULL (processor)
3. Quartz
4. NOR-Flash
5. NAND-Flash
6. Pin 1 marking
7. Power
8. DDR3L

4.3. Bottom Side

Figure 4: Bottom View

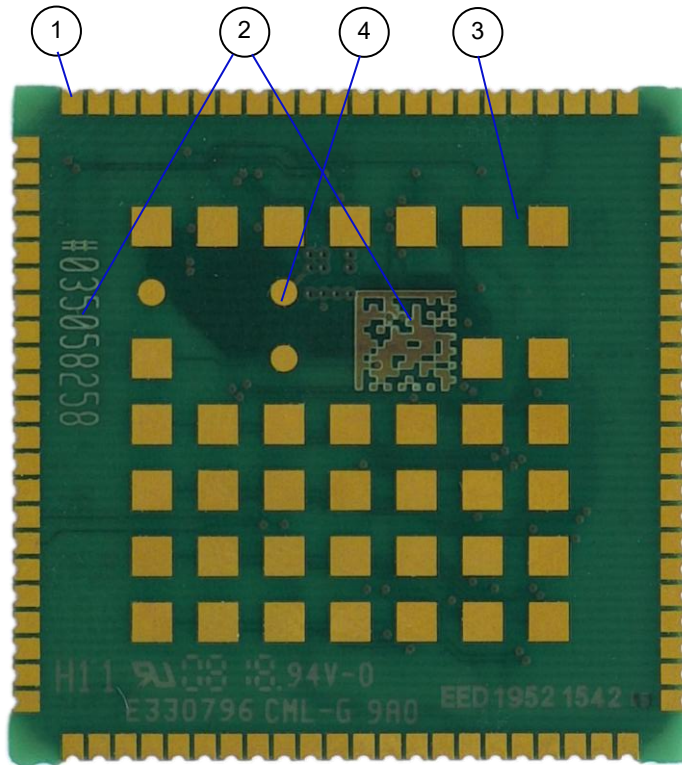

1. Castellations pads
2. Unique ID
3. LGA pads
4. Test points (factory use only)

4.4. Mechanical Drawings

Figure 5: Dimensions of SL iMX6UL/ULL

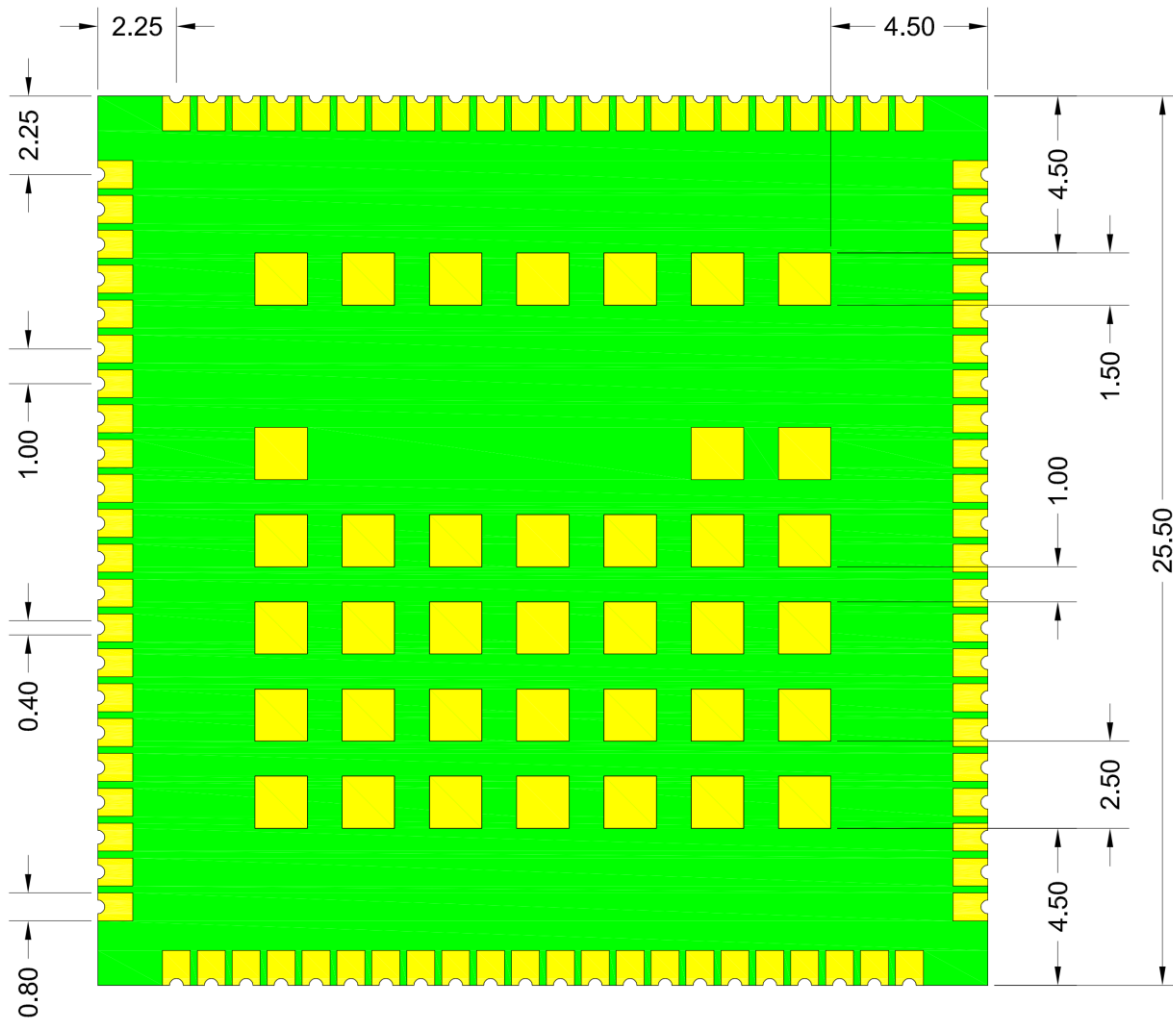

Figure 6: Thickness from side view

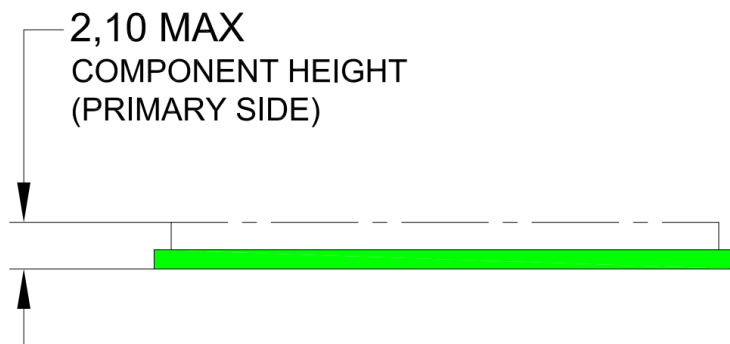
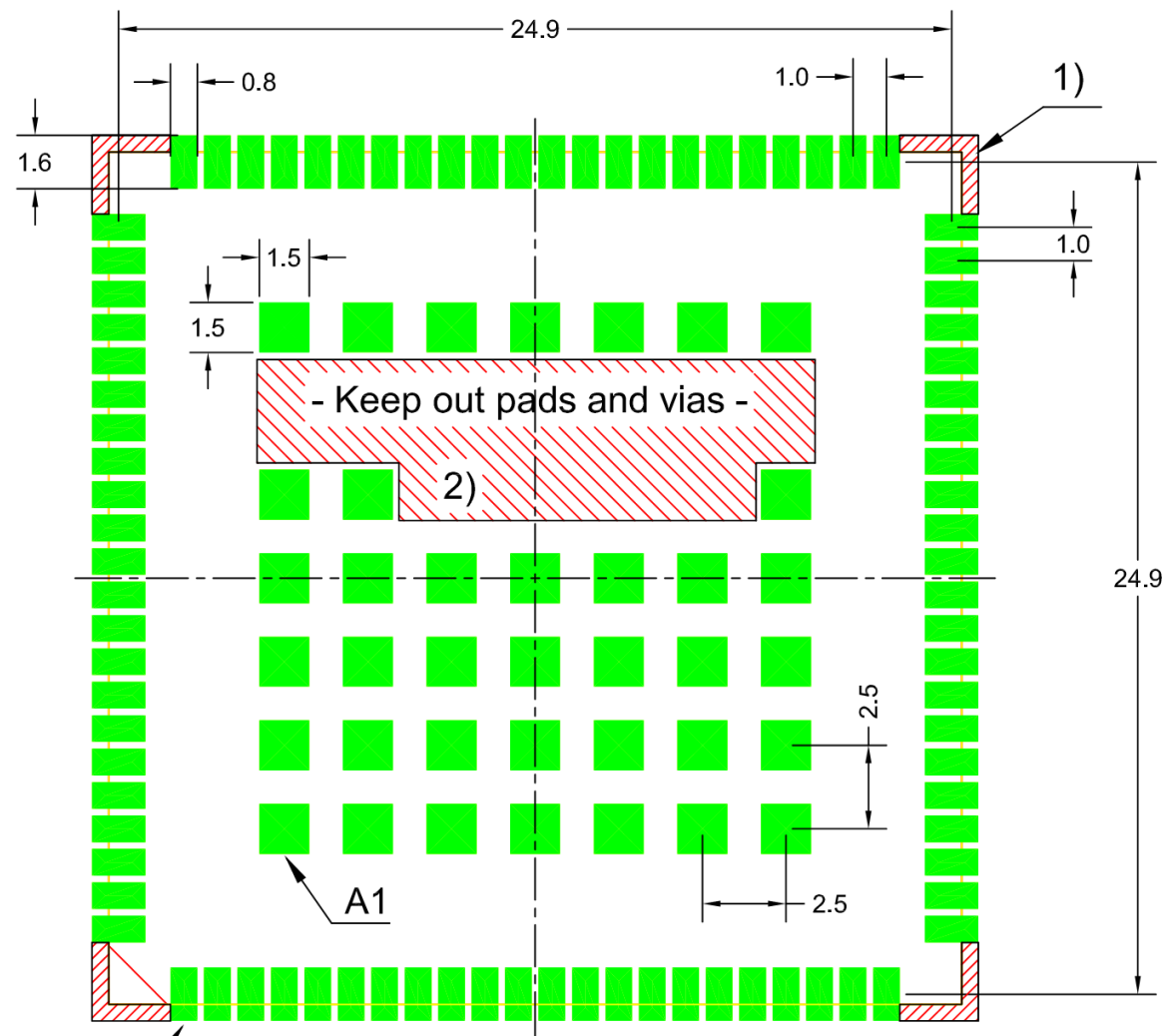

Figure 7: PCB land pattern



PIN 1

- 1) Keep out for components
- 2) Keep out for pads and vias

4.5.1. Pinout of SL iMX6UL/ULL

Table 5: Pinout of SL iMX6UL/ULL castellated pads

Pin	Signal	Module Direction	Module Termination	Type/Tolerance	Controller	Controller Pin	i.MX6UL/ULL Pin
1	USDHC1_DATA0	Bi-Dir	-	CMOS 3.3V	i.MX6UL/ULL	SD1_DATA0	SD1_DATA0
2	USDHC1_CMD	Bi-Dir	-	CMOS 3.3V	i.MX6UL/ULL	SD1_CMD	SD1_CMD
3	USDHC1_CLK	Out	-	CMOS 3.3V	i.MX6UL/ULL	SD1_CLK	SD1_CLK
4	ECSP1_SS0	Out	-	CMOS 3.3V	i.MX6UL/ULL	CSI_DATA05	CSI_DATA05
5	ADC_AIN2	In	-	Analog	i.MX6UL/ULL	GPIO1_IO02	GPIO1_IO02
6	GPIO1_IO05	Out	-	CMOS 3.3V	i.MX6UL/ULL	GPIO1_IO05	GPIO1_IO05
7	NVCC_SD1	Power	-	-	i.MX6UL/ULL	NVCC_SD1	NVCC_SD1
8	I2C1_SDA	Bi-Dir	-	CMOS 3.3V	i.MX6UL/ULL	CSI_MCLK	CSI_MCLK
9	I2C1_SCL	Out	-	CMOS 3.3V	i.MX6UL/ULL	CSI_PIXCLK	CSI_PIXCLK
10	PWM8_OUT	Out	-	CMOS 3.3V	i.MX6UL/ULL	CSI_HSYNC	CSI_HSYNC
11	PWM7_OUT	Out	-	CMOS 3.3V	i.MX6UL/ULL	CSI_VSYNC	CSI_VSYNC
12	UART2_TX	Out	-	CMOS 3.3V	i.MX6UL/ULL	NAND_DATA04	NAND_DATA04
13	UART2_RX	In	-	CMOS 3.3V	i.MX6UL/ULL	NAND_DATA05	NAND_DATA05
14	UART2_CTS_B	Out	-	CMOS 3.3V	i.MX6UL/ULL	NAND_DATA06	NAND_DATA06
15	UART2_RTS_B	In	-	CMOS 3.3V	i.MX6UL/ULL	NAND_DATA07	NAND_DATA07
16	GPIO5_IO00 ¹⁾	In	-	CMOS 3.3V	i.MX6UL/ULL	SNVS_TAMPER0	SNVS_TAMPER0
17	GPIO5_IO01 ¹⁾	Out	-	CMOS 3.3V	i.MX6UL/ULL	SNVS_TAMPER1	SNVS_TAMPER1
18	GPIO5_IO02 ¹⁾	Out	-	CMOS 3.3V	i.MX6UL/ULL	SNVS_TAMPER2	SNVS_TAMPER2
19	GPIO5_IO03 ¹⁾	Out	-	CMOS 3.3V	i.MX6UL/ULL	SNVS_TAMPER3	SNVS_TAMPER3
20	GPIO5_IO04 ¹⁾	In	-	CMOS 3.3V	i.MX6UL/ULL	SNVS_TAMPER4	SNVS_TAMPER4
21	GPIO5_IO05 ¹⁾	Out	-	CMOS 3.3V	i.MX6UL/ULL	SNVS_TAMPER5	SNVS_TAMPER5
22	GPIO5_IO06 ¹⁾	In	-	CMOS 3.3V	i.MX6UL/ULL	SNVS_TAMPER6	SNVS_TAMPER6
23	GND	-	-	-	-	-	-
24	GPIO5_IO07 ¹⁾	-	-	CMOS 3.3V	i.MX6UL/ULL	SNVS_TAMPER7	SNVS_TAMPER7
25	GPIO5_IO08 ¹⁾	-	-	CMOS 3.3V	i.MX6UL/ULL	SNVS_TAMPER8	SNVS_TAMPER8
26	__RESET_OUT	Out	-	CMOS 3.3V	74AUP2G04FW3-7	-	SNVS_TAMPER9
27	GPIO1_IO30	Out	-	CMOS 3.3V	i.MX6UL/ULL	UART5_TX_DATA	UART5_TX_DATA
28	GPIO1_IO31	In	-	CMOS 3.3V	i.MX6UL/ULL	UART5_RX_DATA	UART5_RX_DATA
29	I2C4_SCL	Out	-	CMOS 3.3V	i.MX6UL/ULL	UART2_TX_DATA	UART2_TX_DATA
30	I2C4_SDA	Bi-Dir	-	CMOS 3.3V	i.MX6UL/ULL	UART2_RX_DATA	UART2_RX_DATA
31	CAN2_TX	Out	-	CMOS 3.3V	i.MX6UL/ULL	UART2_CTS_B	UART2_CTS_B
32	CAN2_RX	In	-	CMOS 3.3V	i.MX6UL/ULL	UART2_RTS_B	UART2_RTS_B
33	ADC1_AIN8	In	-	Analog	i.MX6UL/ULL	GPIO1_IO08	GPIO1_IO08
34	__RESET_IN	In	PU-1k5	CMOS 3.3V	PMIC	-	-
35	USB_OTG2_VBUS	Pwr	-	-	i.MX6UL/ULL	USB_OTG2_VBUS	USB_OTG2_VBUS
36	USB_OTG2_DN	Bi-Dir	-	USB	i.MX6UL/ULL	USB_OTG2_DN	USB_OTG2_DN
37	USB_OTG2_DP	Bi-Dir	-	USB	i.MX6UL/ULL	USB_OTG2_DP	USB_OTG2_DP
38	USB_OTG1_VBUS	Pwr	-	-	i.MX6UL/ULL	USB_OTG1_VBUS	USB_OTG1_VBUS
39	USB_OTG1_DN	Bi-Dir	-	USB	i.MX6UL/ULL	USB_OTG1_DN	USB_OTG1_DN
40	USB_OTG1_DP	Bi-Dir	-	USB	i.MX6UL/ULL	USB_OTG1_DP	USB_OTG1_DP
41	USB_OTG1_ID	In	-	CMOS 3.3V	i.MX6UL/ULL	GPIO1_IO00	GPIO1_IO00
42	USB_OTG1_OC	In	-	CMOS 3.3V	i.MX6UL/ULL	GPIO1_IO01	GPIO1_IO01
43	USB_OTG1_PWR	Out	-	CMOS 3.3V	i.MX6UL/ULL	GPIO1_IO04	GPIO1_IO04
44	VCC	Pwr	-	Power	-	-	-

Pin	Signal	Module Direction	Module Termination	Type/Tolerance	Controller	Controller Pin	i.MX6UL/ULL Pin
45	VCC	Power	-	-	-	-	-
46	UART1_TX	Out	-	CMOS 3.3V	i.MX6UL/ULL	UART1_TX_DATA	UART1_TX_DATA
47	UART1_RX	In	-	CMOS 3.3V	i.MX6UL/ULL	UART1_RX_DATA	UART1_RX_DATA
48	UART1_CTS_B	Out	-	CMOS 3.3V	i.MX6UL/ULL	UART1_CTS_B	UART1_CTS_B
49	UART1_RTS_B	In	-	CMOS 3.3V	i.MX6UL/ULL	UART1_RTS_B	UART1_RTS_B
50	ADC1_IN3	In	-	Analog	i.MX6UL/ULL	GPIO1_IO03	GPIO1_IO03
51	VDD_SNVS_IN	Power	-	-	i.MX6UL/ULL	VDD_SNVS_IN	VDD_SNVS_IN
52	UART4_TX ²⁾	Out	-	CMOS 3.3V	i.MX6UL/ULL	UART4_TX_DATA	UART4_TX_DATA
53	UART4_RX ²⁾	In	-	CMOS 3.3V	i.MX6UL/ULL	UART4_RX_DATA	UART4_RX_DATA
54	GPIO1_IO24	In	-	CMOS 3.3V	i.MX6UL/ULL	UART3_TX_DATA	UART3_TX_DATA
55	GPIO1_IO25	In	-	CMOS 3.3V	i.MX6UL/ULL	UART3_RX_DATA	UART3_RX_DATA
56	GPIO1_IO26	In	-	CMOS 3.3V	i.MX6UL/ULL	UART3_CTS_B	UART3_CTS_B
57	GPIO1_IO27	In	-	CMOS 3.3V	i.MX6UL/ULL	UART3_RTS_B	UART3_RTS_B
58	ENET1_MDC	Out	-	CMOS 3.3V	i.MX6UL/ULL	GPIO1_IO07	GPIO1_IO07
59	ENET1_MDIO	Bi-Dir	PU-1k0	CMOS 3.3V	i.MX6UL/ULL	GPIO1_IO06	GPIO1_IO06
60	ETH1_RXM	Bi-Dir	-	PHY	KSZ8081RNB	RXM	RMII
61	ETH1_RXP	Bi-Dir	-	PHY	KSZ8081RNB	RXP	RMII
62	ETH1_TXM	Bi-Dir	-	PHY	KSZ8081RNB	TXM	RMII
63	ETH1_TXP	Bi-Dir	-	PHY	KSZ8081RNB	TXP	RMII
64	ETH1_LED0	Out/OD	-	CMOS 3.3V	KSZ8081RNB	LED0/NWAYEN	RMII
65	ETH1_LED1	Out/OD	-	CMOS 3.3V	KSZ8081RNB	LED1/SPEED	RMII
66	GND	-	-	-	-	-	-
67	ENET2_REF_CLK2	Out	-	CMOS 3.3V	i.MX6UL/ULL	ENET2_TX_CLK	ENET2_TX_CLK
68	ENET2_RX_ER	In	-	CMOS 3.3V	i.MX6UL/ULL	ENET2_RX_ER	ENET2_RX_ER
69	ENET2_TDATA1	Out	-	CMOS 3.3V	i.MX6UL/ULL	ENET2_TX_DATA1	ENET2_TX_DATA1
70	ENET2_RDATA0	In	-	CMOS 3.3V	i.MX6UL/ULL	ENET2_RX_DATA0	ENET2_RX_DATA0
71	ENET2_TX_EN	Out	-	CMOS 3.3V	i.MX6UL/ULL	ENET2_TX_EN	ENET2_TX_EN
72	ENET2_TDATA0	Out	-	CMOS 3.3V	i.MX6UL/ULL	ENET2_TX_DATA0	ENET2_TX_DATA0
73	ENET2_RDATA1	In	-	CMOS 3.3V	i.MX6UL/ULL	ENET2_RX_DATA1	ENET2_RX_DATA1
74	ENET2_RX_EN	In	-	CMOS 3.3V	i.MX6UL/ULL	ENET2_RX_EN	ENET2_RX_EN
75	USDHC2_DATA3	Bi-Dir	-	CMOS 3.3V	i.MX6UL/ULL	NAND_DATA03	NAND_DATA03
76	USDHC2_DATA2	Bi-Dir	-	CMOS 3.3V	i.MX6UL/ULL	NAND_DATA02	NAND_DATA02
77	USDHC2_DATA1	Bi-Dir	-	CMOS 3.3V	i.MX6UL/ULL	NAND_DATA01	NAND_DATA01
78	USDHC2_DATA0	Bi-Dir	-	CMOS 3.3V	i.MX6UL/ULL	NAND_DATA00	NAND_DATA00
79	USDHC2_CMD	Bi-Dir	-	CMOS 3.3V	i.MX6UL/ULL	NAND_WE_B	NAND_WE_B
80	USDHC2_CLK	Out	-	CMOS 3.3V	i.MX6UL/ULL	NAND_RE_B	NAND_RE_B
81	USDHC2_RESET	Out	-	CMOS 3.3V	i.MX6UL/ULL	NAND_ALE	NAND_ALE
82	ECSPI1_MISO	In	-	CMOS 3.3V	i.MX6UL/ULL	CSI_DATA07	CSI_DATA07
83	ECSPI1_MOSI	Out	-	CMOS 3.3V	i.MX6UL/ULL	CSI_DATA06	CSI_DATA06
84	ECSPI1_SCLK	Out	-	CMOS 3.3V	i.MX6UL/ULL	CSI_DATA04	CSI_DATA04
85	USDHC1_DATA3	Bi-Dir	-	CMOS 3.3V	i.MX6UL/ULL	SD1_DATA3	SD1_DATA3
86	USDHC1_DATA2	Bi-Dir	-	CMOS 3.3V	i.MX6UL/ULL	SD1_DATA2	SD1_DATA2
87	USDHC1_DATA1	Bi-Dir	-	CMOS 3.3V	i.MX6UL/ULL	SD1_DATA1	SD1_DATA1
88	GND	-	-	-	-	-	-

1) Pins are connected to the RTC supply (SNVS_IN) and can influence RTC power consumption. See Chapter 4.4, AN5170.pdf by NXP

2) Used as Linux console

Table 6: Pinout of SL iMX6UL/ULL LGA pads

Pin	Signal	Module Direction	Module Termination	Type/Tolerance	Controller	Controller Pin	i.MX6UL/ULL Pin
A1	LCDIF_DATA6	Out	-	CMOS 3.3V	i.MX6UL/ULL	LCD_DATA06	LCD_DATA06
A2	LCDIF_DATA13	Out	-	CMOS 3.3V	i.MX6UL/ULL	LCD_DATA13	LCD_DATA13
A3	LCDIF_DATA20	Out	-	CMOS 3.3V	i.MX6UL/ULL	LCD_DATA20	LCD_DATA20
A4	LCDIF_VSYNC	Out	-	CMOS 3.3V	i.MX6UL/ULL	LCD_VSYNC	LCD_VSYNC
A5	BOOT_MODE1	In	-	CMOS 3.3V	i.MX6UL/ULL	BOOT_MODE1	BOOT_MODE1
A7	BOOT_MODE0	In	-	CMOS 3.3V	i.MX6UL/ULL	BOOT_MODE0	BOOT_MODE0
B1	LCDIF_DATA5	Out	-	CMOS 3.3V	i.MX6UL/ULL	LCD_DATA05	LCD_DATA05
B2	LCDIF_DATA12	Out	-	CMOS 3.3V	i.MX6UL/ULL	LCD_DATA12	LCD_DATA12
B3	LCDIF_DATA19	Out	-	CMOS 3.3V	i.MX6UL/ULL	LCD_DATA19	LCD_DATA19
B4	LCDIF_HSYNC	Out	-	CMOS 3.3V	i.MX6UL/ULL	LCD_HSYNC	LCD_HSYNC
B5	ONOFF	In	-	CMOS 3.3V	i.MX6UL/ULL	ONOFF	ONOFF
B7	JTAG_TRST_B	In	-	CMOS 3.3V	i.MX6UL/ULL	JTAG_TRST_B	JTAG_TRST_B
C1	LCDIF_DATA4	Out	-	CMOS 3.3V	i.MX6UL/ULL	LCD_DATA04	LCD_DATA04
C2	LCDIF_DATA11	Out	-	CMOS 3.3V	i.MX6UL/ULL	LCD_DATA11	LCD_DATA11
C3	LCDIF_DATA18	Out	-	CMOS 3.3V	i.MX6UL/ULL	LCD_DATA18	LCD_DATA18
C4	LCDIF_CLK	Out	-	CMOS 3.3V	i.MX6UL/ULL	LCD_CLK	LCD_CLK
C7	JTAG_TCK	In	-	CMOS 3.3V	i.MX6UL/ULL	JTAG_TCK	JTAG_TCK
D1	LCDIF_DATA3	Out	-	CMOS 3.3V	i.MX6UL/ULL	LCD_DATA03	LCD_DATA03
D2	LCDIF_DATA10	Out	-	CMOS 3.3V	i.MX6UL/ULL	LCD_DATA10	LCD_DATA10
D3	LCDIF_DATA17	Out	-	CMOS 3.3V	i.MX6UL/ULL	LCD_DATA17	LCD_DATA17
D4	LCDIF_ENABLE	Out	-	CMOS 3.3V	i.MX6UL/ULL	LCD_ENABLE	LCD_ENABLE
D7	JTAG_TDI	In	-	CMOS 3.3V	i.MX6UL/ULL	JTAG_TDI	JTAG_TDI
E1	LCDIF_DATA2	Out	-	CMOS 3.3V	i.MX6UL/ULL	LCD_DATA02	LCD_DATA02
E2	LCDIF_DATA9	Out	-	CMOS 3.3V	i.MX6UL/ULL	LCD_DATA09	LCD_DATA09
E3	LCDIF_DATA16	Out	-	CMOS 3.3V	i.MX6UL/ULL	LCD_DATA16	LCD_DATA16
E4	LCDIF_DATA23	Out	-	CMOS 3.3V	i.MX6UL/ULL	LCD_DATA23	LCD_DATA23
E7	JTAG_TDO	Out	-	CMOS 3.3V	i.MX6UL/ULL	JTAG_TDO	JTAG_TDO
F1	LCDIF_DATA1	Out	-	CMOS 3.3V	i.MX6UL/ULL	LCD_DATA01	LCD_DATA01
F2	LCDIF_DATA8	Out	-	CMOS 3.3V	i.MX6UL/ULL	LCD_DATA08	LCD_DATA08
F3	LCDIF_DATA15	Out	-	CMOS 3.3V	i.MX6UL/ULL	LCD_DATA15	LCD_DATA15
F4	LCDIF_DATA22	Out	-	CMOS 3.3V	i.MX6UL/ULL	LCD_DATA22	LCD_DATA22
F7	JTAG_TMS	Bi-Dir	-	CMOS 3.3V	i.MX6UL/ULL	JTAG_TMS	JTAG_TMS
G1	LCDIF_DATA0	Out	-	CMOS 3.3V	i.MX6UL/ULL	LCD_DATA00	LCD_DATA00
G2	LCDIF_DATA7	Out	-	CMOS 3.3V	i.MX6UL/ULL	LCD_DATA07	LCD_DATA07
G3	LCDIF_DATA14	Out	-	CMOS 3.3V	i.MX6UL/ULL	LCD_DATA14	LCD_DATA14
G4	LCDIF_DATA21	Out	-	CMOS 3.3V	i.MX6UL/ULL	LCD_DATA21	LCD_DATA21
G5	LCDIF_RESET	Out	-	CMOS 3.3V	i.MX6UL/ULL	LCD_RESET	LCD_RESET
G7	JTAG_MOD	Out	PD-4k75	CMOS 3.3V	i.MX6UL/ULL	JTAG_MOD	JTAG_MOD

5/ Installation

5.1. Power Control

5.1.1. Power Supply

The SoM can be powered from a single 3.3V power Source at VCC pins. The VDD_SNVS_IN pin can be connected to an external battery. If no external battery is used, it is mandatory to connect this pin to VCC.

NVCC_SD1 is used to power the SDIO1 interface. If UHS-I mode is used, card voltage must be lowered to 1.8 V according to pin SDIO1_VSELECT. If UHS-I mode is not used, NVCC_SD1 can be connected to VCC.

Small decoupling capacitors like 100nF should be used for each supply pin and should be placed as close as possible.

If USB is unused VBUS can be left floating. Otherwise connect VBUS to +5 V.



The following parameters should be delivered from the carrier board:

- ▶ Voltage Ripple maximum 100 mV peak to peak 0-20 MHz, 20 ms rise time from input voltage <10% to nominal VCC
-

5.1.2. Supply voltage

Table 7: Supply voltage

Voltage	nominal	min	max
VCC	3.3 V	3.0 V	3.6 V
VDD_SNVS_IN	3.3 V	2.4 V	3.6 V
USB_OTG1/2_VBUS	5.0 V	4.4 V	5.5 V
NVCC_SD1	3.3/1.8 V	1.65 V	3.6 V

5.1.3. Supply current

Table 8: Supply current

Use case	mean	max
Linux running	110 mA	-
A7 heavy load	190 mA	260 mA



At power on, the SoM can cause a current spike of up to 1.5A for 5 μ s. Make sure to have a low impedance path from the supply to the SoM or enough capacity to buffer the spike, otherwise the resulting voltage drop will lead to male function.

5.2. Reset pin

A low level at __RESET_IN triggers a reset. The module will stay in reset as long as __RESET_IN is grounded. If unused, this pin can be left floating. No external components are required.

5.3. Boot Mode

The device has four boot modes (one is reserved for NXP use).

Table 9: Boot mode pin settings

BOOT_MODE[1:0]	Boot Type
00	Boot From Fuses
01	Serial Downloader
10	Internal Boot
11	Reserved

BOOT_MODE[1:0] pins have internal pull-downs. By default, these pins can be left floating to stay in “Boot from Fuses” mode. In this mode the SoM boots as programmed by Kontron.

5.3.1. SD/MMC manufacture mode

If no valid boot image is found on the programmed boot devices the SoM switches to SD/MMC manufacture mode before the serial download mode. In the manufacture mode, the SD or MMC card will be scanned on the uSDHC1. If a card is detected and a valid boot image is found in the card, the boot image is loaded and executed. Pad 49 of the SoM acts as SD1_CD and is used to detect whether a card is inserted or not.

5.3.2. Serial Downloader

The Serial Downloader provides a means to download a program image to the chip over the USB OTG1 or UART 1/2 serial connection.



It is recommended to have the boot pins and the OTG1 pins available on the baseboard to recover the SoM in case of a broken image. In addition, also the SD1 pins including the SD1_CD pin and the pins for the Linux console can be useful.

5.4. SD card

Figure 9: SD-Card connection example

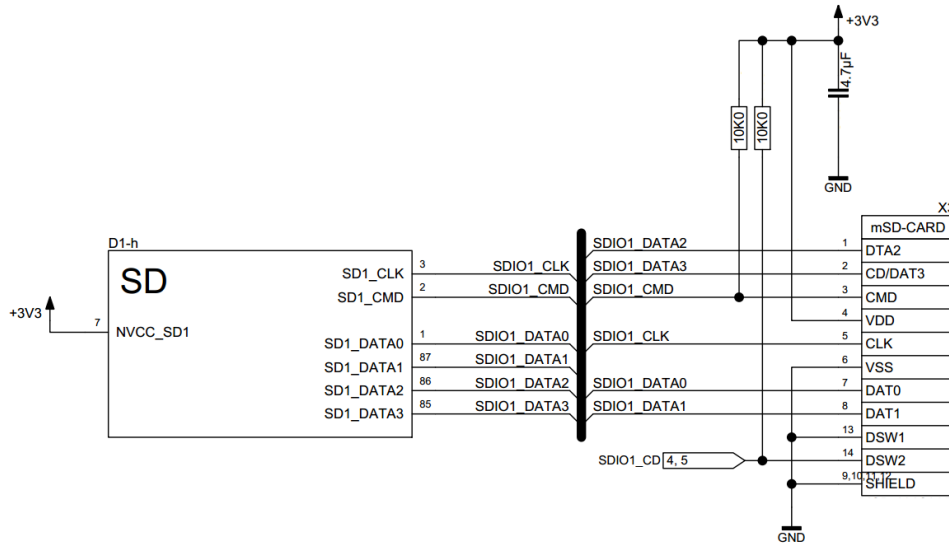

5.5. Ethernet

The SL iMX6UL/ULL includes the 100Mbit Phy KSZ8081RNBIA. This makes the ethernet implementation on the baseboard quite simple. Only an appropriate connector with magnetics has to be connected.

Figure 10: Ethernet connection example

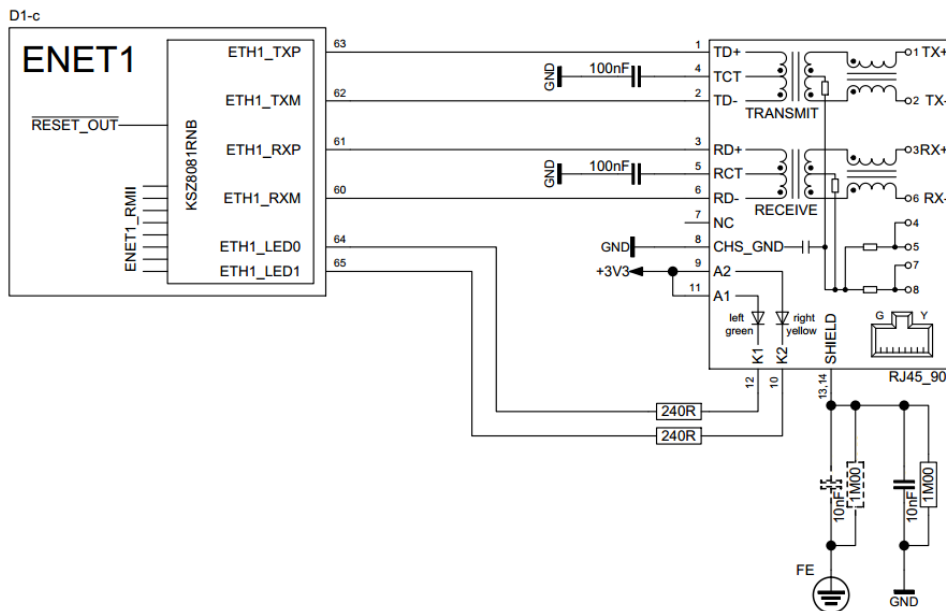

6/ Thermal considerations

The temperature rise of the CPU depends on the use case and varies from 20°C for “Linux running” up to approximately 45°C for “A7 heavy load”.

Due to the maximum temperature of 105°C of the SoC a cooling concept should be considered depending on the CPU load and the maximum ambient temperature.

7/ Reflow profile

Table 10: Reflow profile

Profile Feature	Pb-Free Assembly
Average Ramp-Up Rate (T_{SMAX} to T_P)	3°C/second max.
Preheat	
Temperature Min (T_{SMIN})	150 °C
Temperature Max (T_{SMAX})	200 °C
Time (t_s) from (T_{SMIN} to T_{SMAX})	60-120 seconds
Liquidous temperature (T_L)	217 °C
Time (t_L) maintained above T_L	60-80 seconds
Peak/Classification Temperature (T_P)	250 °C
Time within 5 °C of actual peak temperature (t_p)	20 seconds
Ramp-down rate	6°C/second max
Time 25 °C to peak temperature	8 minutes max

Figure 11: Reflow Classification Profile

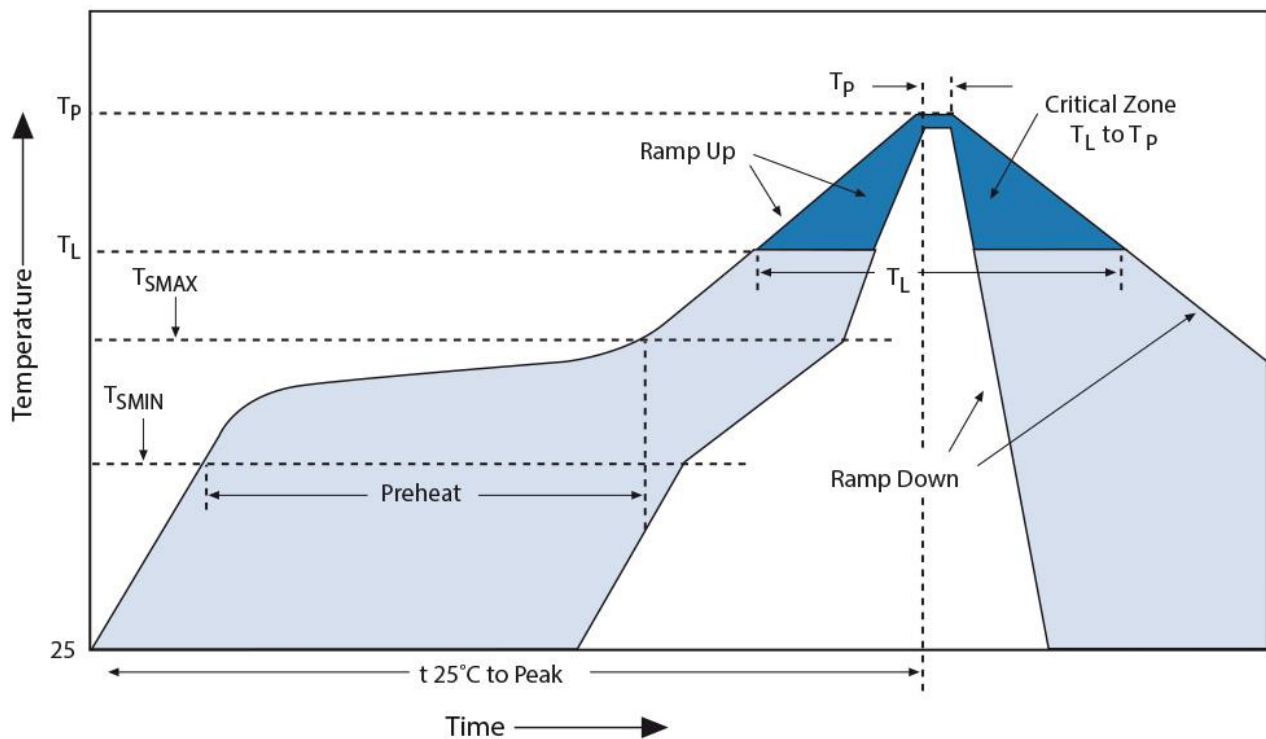

To minimize the stress for the components, it is strongly recommended to solder the SoM during the last reflow cycle of the carrier board manufacturing process.

8/ Technical Support

8.1. First Steps - Startup-Information Baseboard

For the first startup of your Board, which includes the SL iMX6UL/ULL SoM, you will find more information about the Software / BSP and additional hardware information at the online documentation.

Please follow the link <https://docs.kontron-electronics.de/yocto-ktn/build-ktn-rocko/>

The online documentation is primarily intended for our Eval-Kit / Evalboard, but will help you also to put your board into operation. Additionally, you will find information how to get access to the Yocto based GitLab software repository and how to make your own software images.

8.2. Extended Support

For detailed technical support please contact:

- ▶ E-Mail: support@kontron-electronics.de

8.3. Disclaimer & License Information

The software contained in the device (BSP) contains parts which were licensed as free respectively open source software under the GNU General Public License, version 2 and/or 3, respectively the GNU Lesser General Public License, versions 2.1 and/or 3.0.

You can obtain a copy of the source code of the BSP by following the instructions in the manual at <https://docs.kontron-electronics.de/> or contact:

Kontron Electronics GmbH
Max-Planck-Str. 6
72636 Frickenhausen
Germany
Web: www.kontron-electronics.de
E-Mail: support@kontron-electronics.de

About Kontron Electronics

Kontron Electronics is your complete supplier of electronics and automation solutions. We offer

- ▶ own control products for the automation of machines and devices,
- ▶ Development and production for individual, complex electronic modules
- ▶ Production services for your existing electronic assemblies
- ▶ Assembly services for complete systems

With our existing control, visualisation and automation systems, we can put together turnkey complete solutions for your machines and equipment in the shortest possible time.

For your individual requirements we have a large group of engineers and technicians available, who develop your tailor-made solution with a lot of experience and imagination.

Kontron Electronics is a full-service provider for the development and production of complex electronic modules, components and systems for industrial and medical applications.



Kontron Electronics
GmbH

Max-Planck-Str. 6
72636 Frickenhausen
Germany
Tel.: +49 7022 4057-0
Fax: +49 7022 4057-22
info@kontron-electronics.de